



Indino 4.0



Indino 4.0



Contents

1.Introduction: 3

2. Features 4

3. Benefits 6

4. Applications..... 6

5. Block Diagram..... 6

6.a)Digital IO Pin Configuration(INDINO-8000,8005,8030,8040,8050,8060): 10

6.b)Analog IO Pin Configuration (INDINO-8021 Analog IO TC): 11

6.c)Analog IO Pin Configuration (INDINO-8020 Analog IO RTD): 12

7.a)Digital pin mapping.....14

7.b)Analog pin mapping.....17

8. Programming IDE..... 19

9. Product Specification 19

 9.1 Digital Input..... 19

 9.2 Digital Output 22

 9.3 SD Card 24

 9.4 RTC 24

 9.5 FRAM..... 25

 9.7. Flash 26

 9.8. ESP32..... 27

 9.9. RS485 Modbus 28

 9.10. RS232 30

 9.11. Status LED Display 32

 9.12. RDL BUS 32

10.InterfacingIndinowithRaspberry 34

11.InterfacingIndinowithIntel NUC 36

12. InterfacingIndinowithAndroid Tab 38

13. InterfacingIndinowith Beaglebone 40

14.Order Information Table 41

15.Mounting and Mechanical Dimensions 42



1. Introduction:

Indino 4.0 series defines a new way of transforming factories into smart/intelligent factories for efficient and easy remote monitoring operational status of facilities such as on/off status, pressure and temperature. Indino 4.0 supporting for wide range of industrial protocols like Modbus, MQTT, JSON, RESTful,TCP/UDP , SNMP protocol ,which makes the monitoring and solution integration, easier than ever for IT engineers through open source APIs,.

The base board on Atmega2560 controller with BLE and WiFi having processor ESP32 -32-bit LX6 processor -200 MIPS supporting OTA, having on board capabilities like 8MByte Embedded Flash, 256KByte FRAM, SDcard -32GB, USB , RS232 , RS485 ,PWDT , 12 channel 24 V opto isolated IO supported for wet and dry connection ,RTC , RDL Expansion bus for add on modules expanding the IO needs and DC to DC converter support for 12 to 36V input DC supply .





2. Features

Processor: Tensilica Xtensa 32-bit LX6 microprocessor

- **Clock frequency:** up to 240 MHz ,up to 600 DMIPS
- **ROM:** 448 KB **SRAM:** 520 KB

Co controller *:

ATmega 2560, 16MHz, FLASH 256KB/STM32

Digital IO

24v 8x Isolated Enabled digital input

24v 4x Isolated Digital output / PWM 1 Amps max

AC Isolation: 3750VRMS

Contacts supported: DRY / WET

Analog IO

4x ADC 0-10V/ 4-20mA max

8 bit ADC offers high resolution

Wired Connectivity

RS485 MODBUS , RS232 & USB

RDL expansion bus

Memory

FRAM 25KB , SD CARD 32GB

RTC

Built-in RTC for stamped data logging

Wireless connectivity:

- **Wi-Fi:** 802.11 b/g/n/e/i (802.11n @ 2.4 GHz up to 150 Mbit/s)
- **Bluetooth:** v4.2 BR/EDR and Bluetooth Low Energy (BLE)

Protocol

- TCP-IP, UDP, SNMP, MODBUS, FTP, RESTFULL, JSON&MQTT

Security:

- IEEE 802.11 security features : WFA, WPA/WPA2 and WAPI



- Secure boot / Flash encryption
- 1024-bit OTP, up to 768-bit for customers
- Cryptographic hardware acceleration: AES, SHA-2, RSA, ECC & random number generator (RNG).

Enclosure :

IP 20

mounting :Wall / DIN Rail

Dimension :108 x 41.2 x 20

*Co Controller information is given in product information page

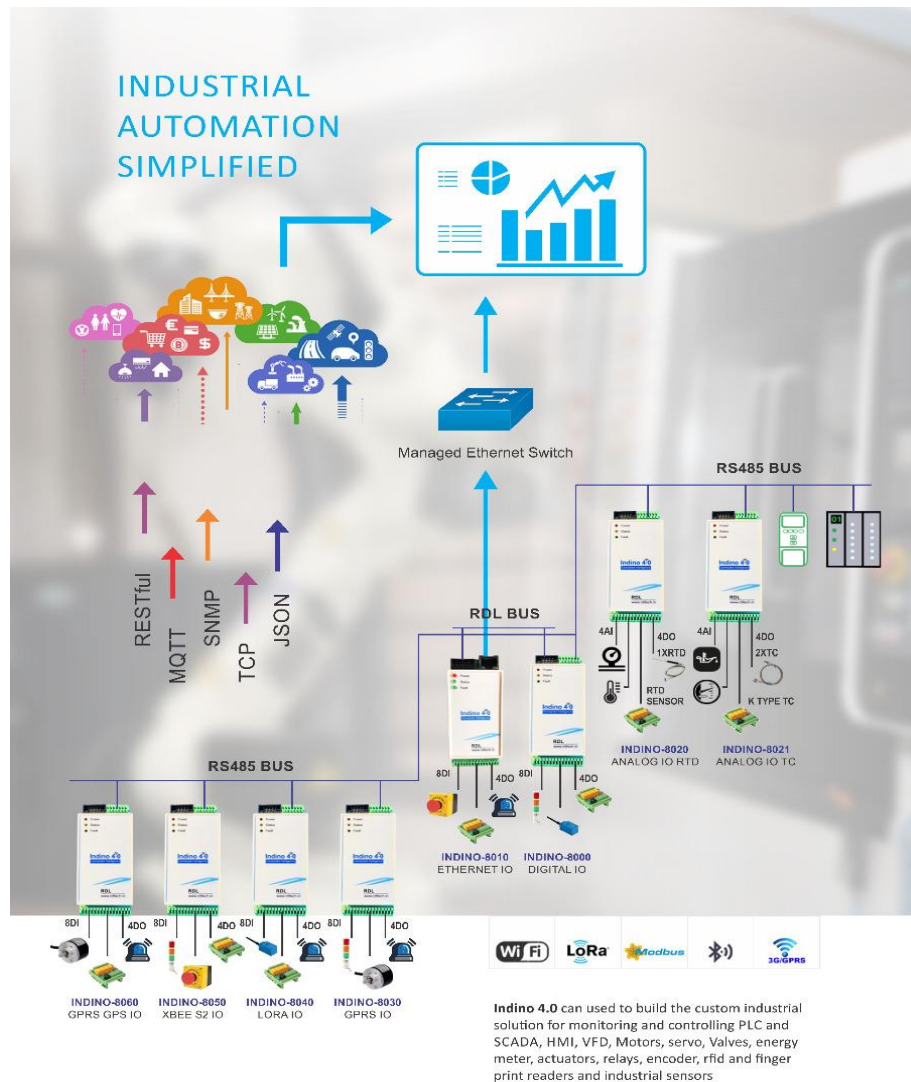



3. Benefits

Indino 4.0 can be used to build the custom industrial solution for monitoring and controlling PLC and SCADA, HMI, VFD, Motors, servo, Valves, energy meter, actuators, relays, encoder, rfid and finger print readers, industrial sensors and many more with below mentioned operational benefits.

- Improved productivity.
- Reduced downtime.
- Maximized asset utilization.
- Tracking trends for real-time marketing.
- Enhanced situational awareness.
- Sensor-driven decision analytics.
- Instantaneous control and response in complex autonomous systems

4. Applications

This product is used for many industrial applications like

- Production and process Management
- Utilities Management
- Condition Management
- Environment Management
- Industrial Smart grid
- Leakage detection
- Cold storage Management
- District metering
- Water treatment
- Generator Management
- Green House.
- Warning message in case of calamities.
- Remote system management



5. Block Diagram of INDINO -8005, 8030,8040,8050,8060

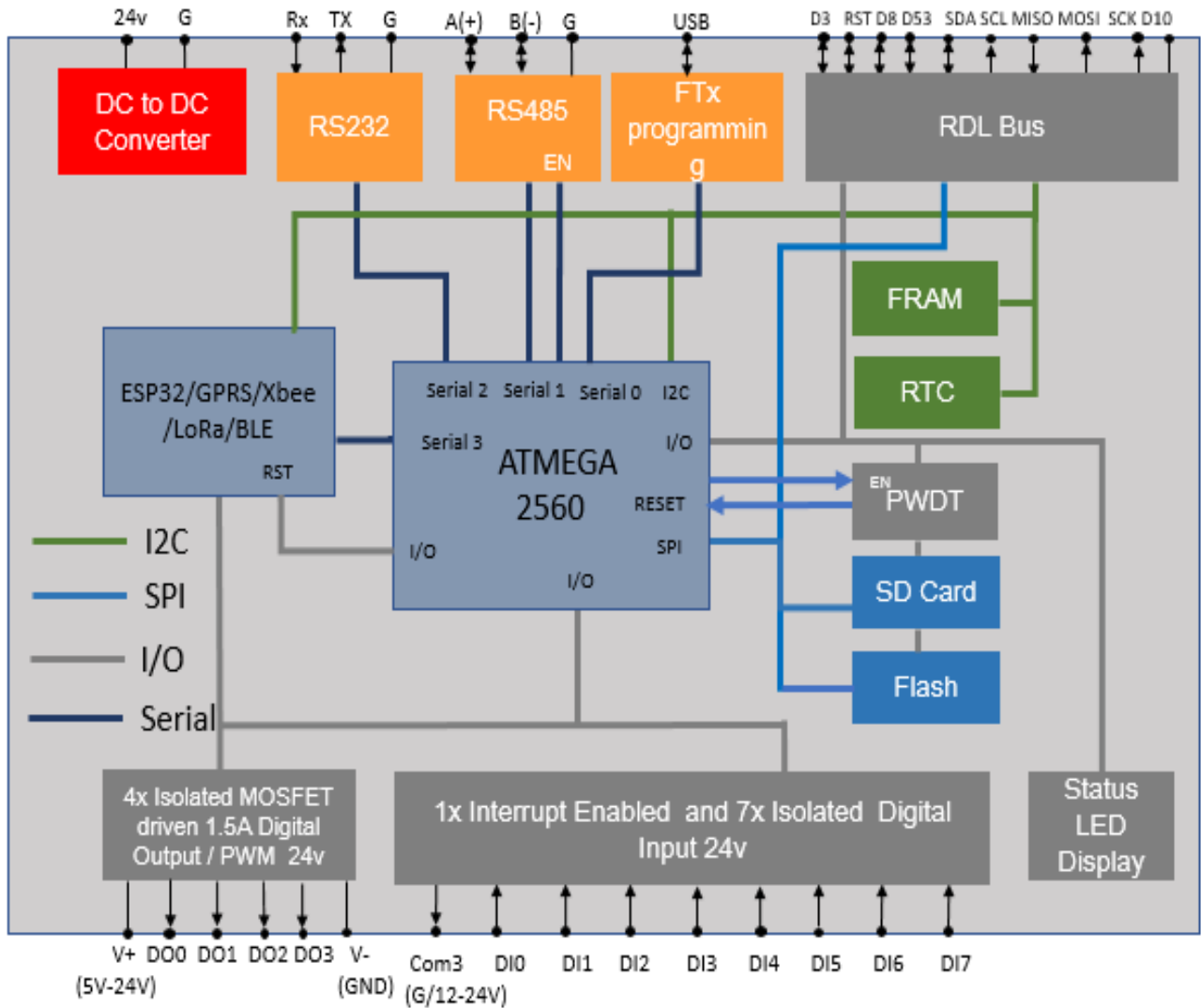



5.1 Block Diagram of INDINO-8020 Analog IO RTD

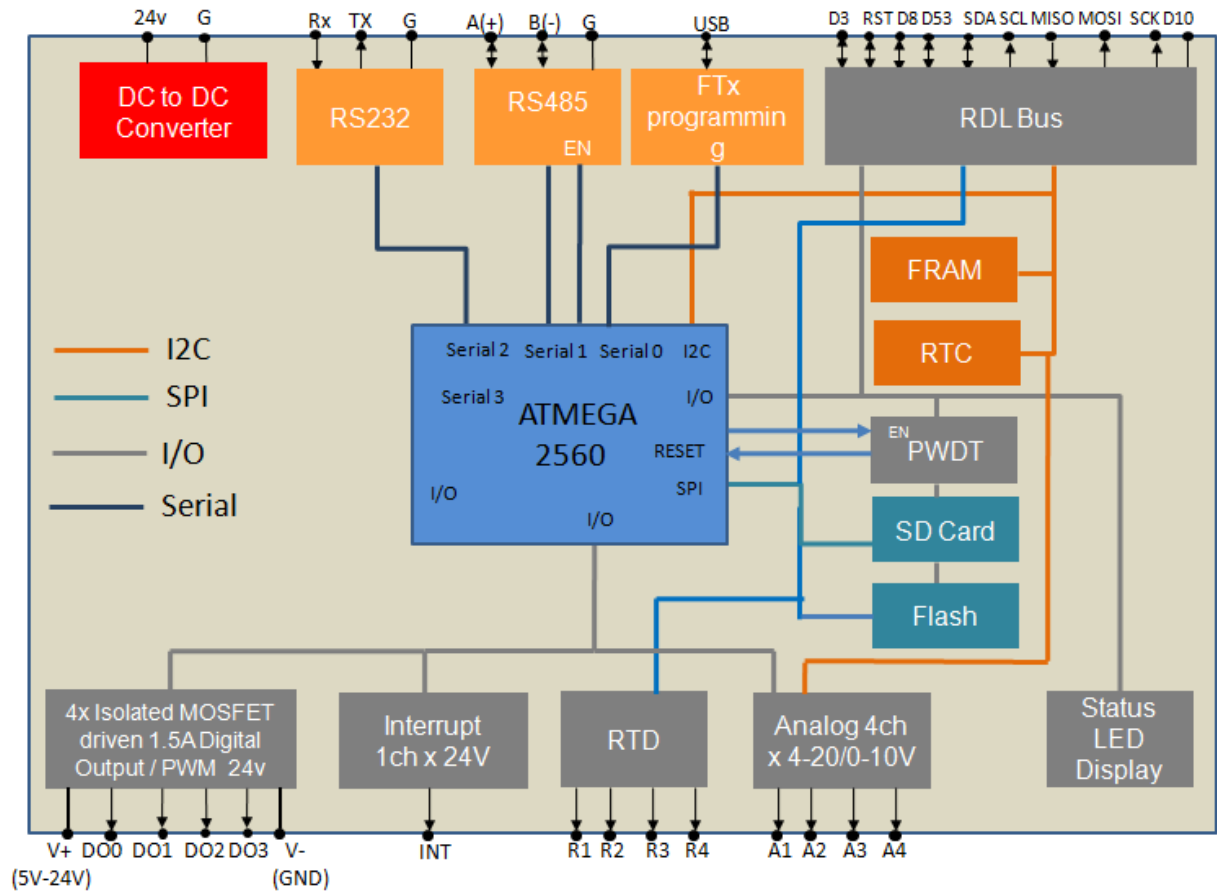



5.2 Block Diagram of INDINO-8021 Analog IO TC

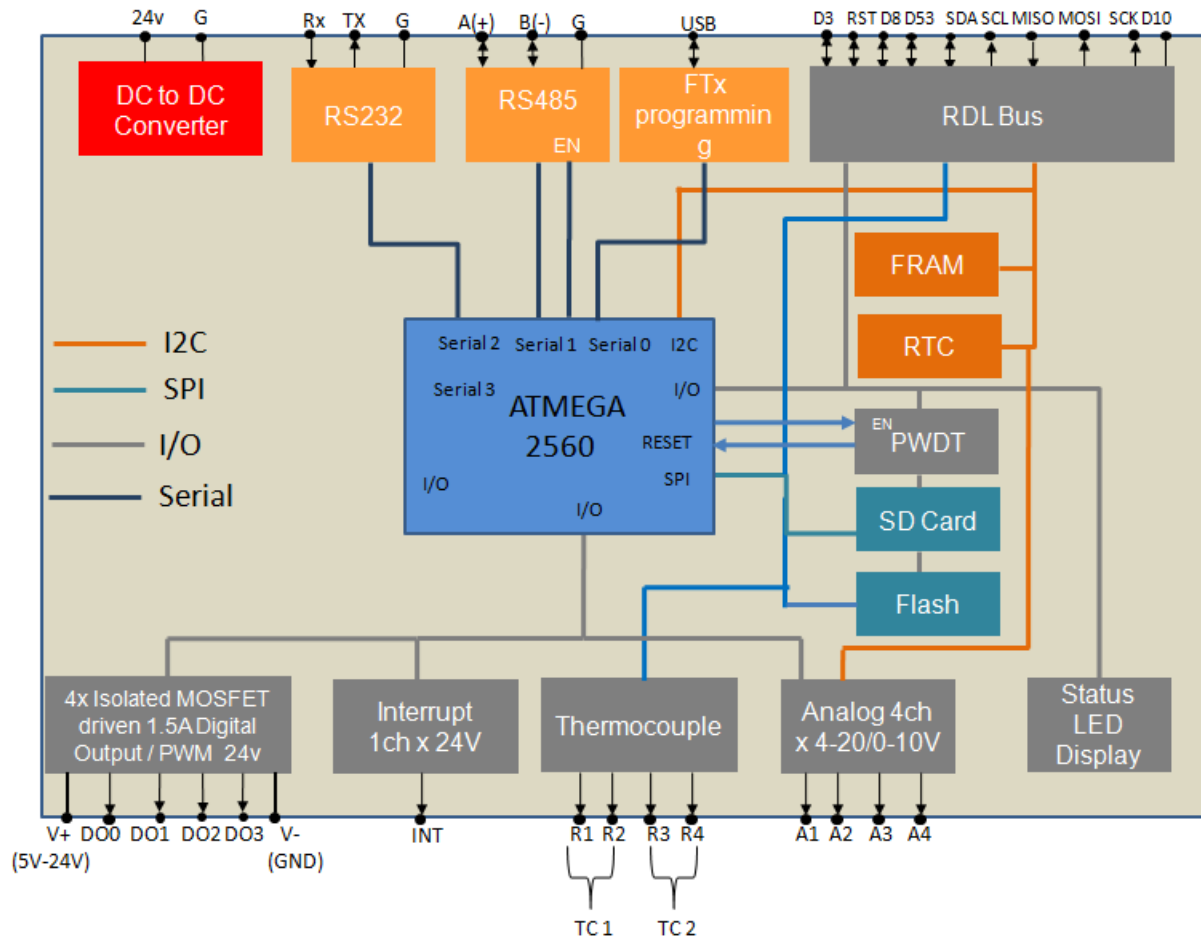



6.a) Digital IO Pin Configuration(INDINO-8000,8005,8030,8040,8050,8060):

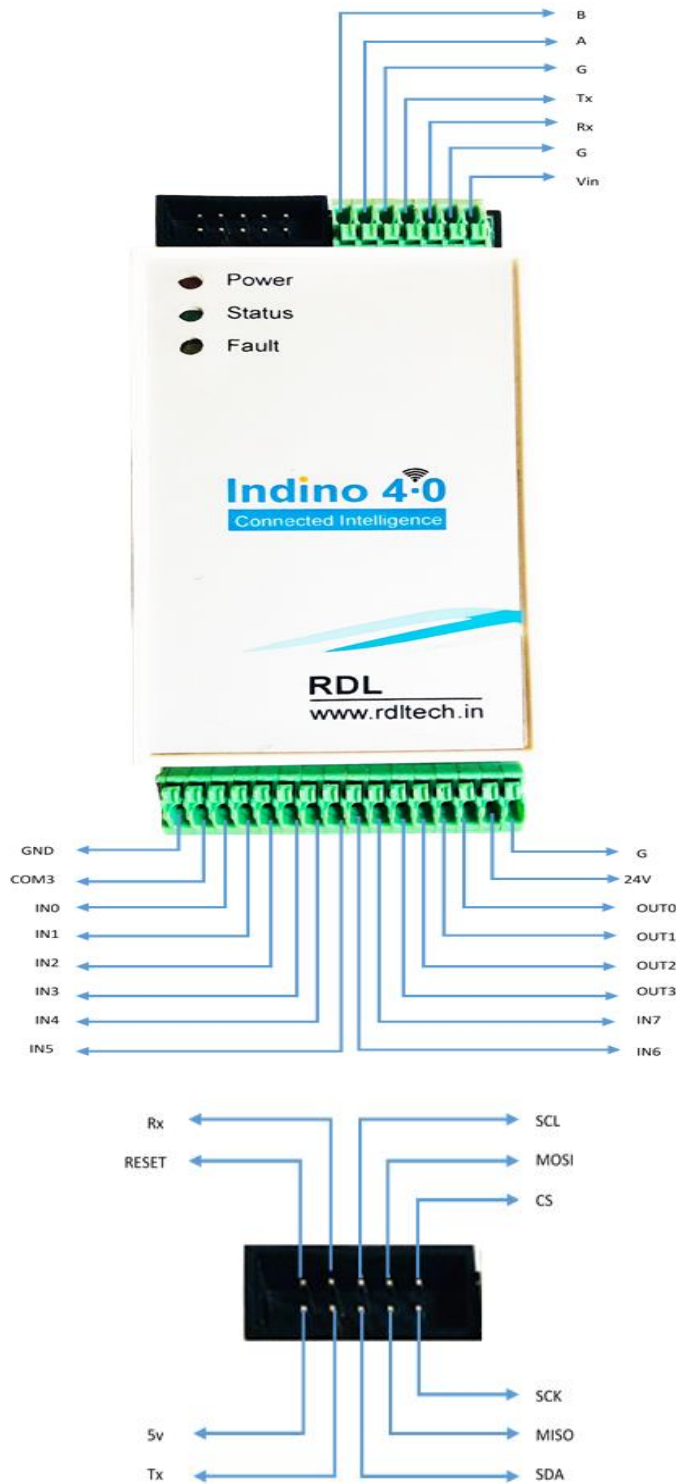



6.b) Analog IO Pin Configuration (INDINO-8021 Analog IO TC):

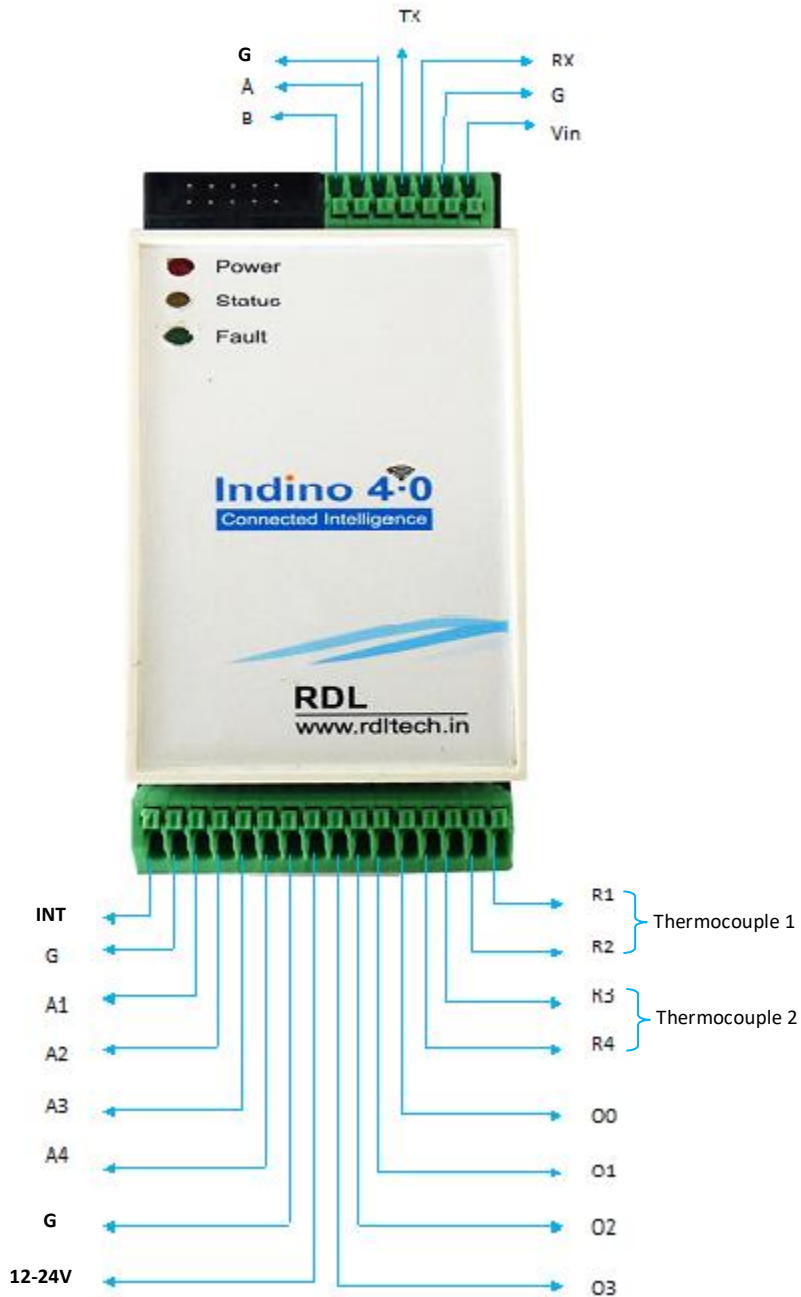



6.c) Analog IO Pin Configuration (INDINO-8020 Analog IO RTD):

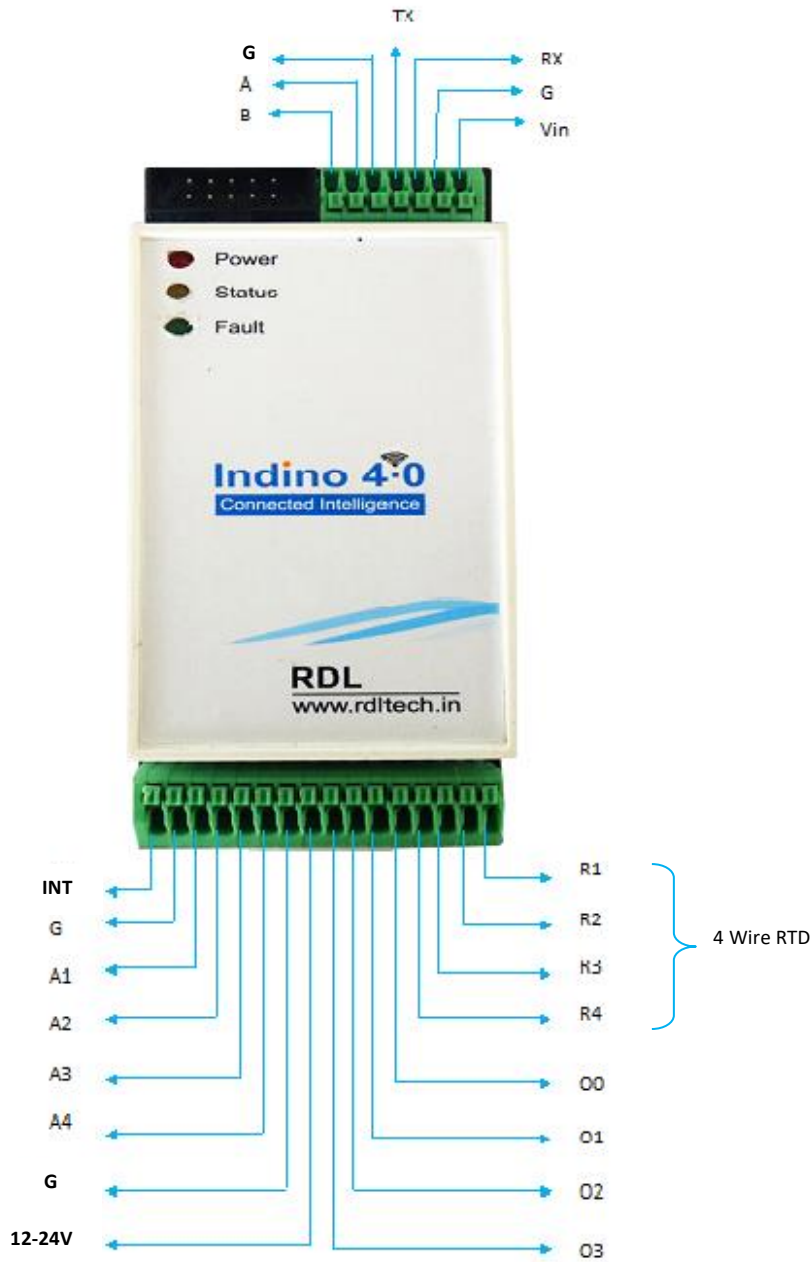

Wiring Diagram for RTD:

2 wire RTD:

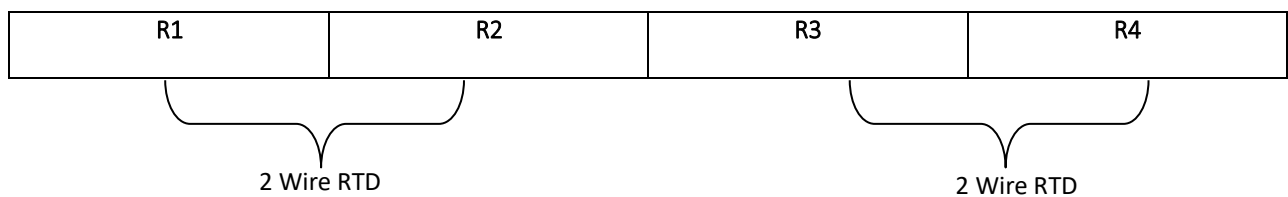



3 wire RTD:

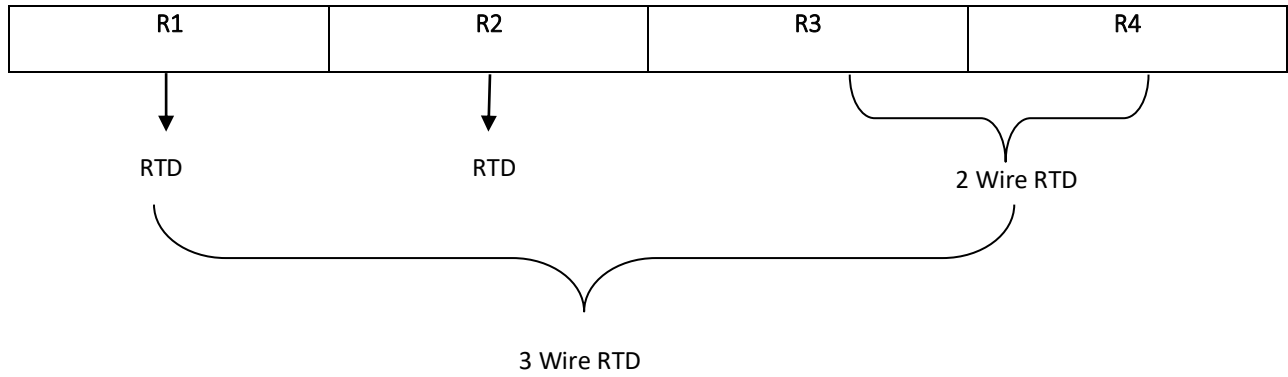



7.a) Digital PinMapping (INDINO-8000,8005,8030,8040,8050,8060)

Function Blocks	Description	Pins(UNO)	Pins(Atmega)
MAX232	TXD1	D18	PD3
	RXD1	D19	PD2
RS485	RXD2	D17	PH0
	TXD2	D16	PH1
	Enable	D6	PH3
Physical Watch Dog Timer max 3 minutes	Enable	D23	PA1
	Reset	D22	PA0
Opto Isolated Input 24V	IN0	D35	PC2
	IN1	D34	PC3
	IN2	D33	PC4
	IN3	D32	PC5
	IN4	D31	PC6
	IN5	D30	PC7
	IN6	D39	PG2
	IN7	D2	PE4
MOSFET Driven 1.5A PWM/Output 24V	Output1	D7	PH4
	Output2	D12	PB6
	Output3	D4	PG5
	Output4	D5	PE3



SD Card	MISO	D50	PB3
	MOSI	D51	PB2
	SCK	D52	PB1
	SD_CS	D9	PH6
FLASH 8MB	MISO	D50	PB3
	MOSI	D51	PB2
	SCK	D52	PB1
	SRAM_CS	D11	PB5
FT230x-USB	TXD0	D1	PE1
	RXD0	D0	PE0

FRAM	SCL	D21	PD0
	SDA	D20	PD1
RTC	SCL	D21	PD0
	SDA	D20	PD1
ESP32/GPRS/Xbee /LoRa/BLE	TX3	D14	PJ1
	RX3	D15	PJ0
	RESET	D36	PC1
	GPIO16	D37	PC0
	POWER_KEY(GSM/GPRS)	D41	PG0
	MIC_Input(GSM/GPRS)	D46	PL3



RDL Bus			
ISP / IO expander mode*	PWM (INT)	D3	PE5
	RST/G*	RST	RESET
	PWM	D8	PH5
	INT0	D53	PB0
	SCL	D21	PD0
	SDA	D20	PD1
	MISO	D50	PB3
	MOSI	D51	PB2
	SCK	D52	PB1
	PWM	D10	PB4
Status LED	PWR	+5V	+5V
	STAT	D13	PB7
	FLT	D49	PL0

***Note: ISP/IO expander selection modeset the jumpers as shown in the figure.**



7. b) Analog PinMapping(INDINO-8020,8021)

Function Block	Description	Pins(UNO)	Pins(Atmega)
MAX232	TXD1	D18	PD3
	RXD1	D19	PD2
RS485	TXD2	D16	PH1
	RXD2	D17	PH0
	Enable	D9	PH9
Physical Watch Dog Timer max 3 minute	Enable	D23	PA1
	Pulse Input	D22	PA0
ADC/4-20mA Select 0-----analog 1-----4-20mA	ADC1	D40	PG1
	ADC2	D37	PC0
	ADC3	D38	PD7
	ADC4	D41	PG0
ADC/4-20mA	SDA	D20	PD1
	SCL	D21	PD0
MOSFET Driven 1.5A PWM/Output 24v	Output1	D7	PH4
	Output2	D4	PG5
	Output3	D6	PH3
	Output4	D5	PE3
SD Card	MISO	D50	PB3
	MOSI	D51	PB2
	SCK	D52	PB1
	SD_CS	D11	PB5
FLASH 8MB	MISO	D50	PB3
	MOSI	D51	PB2
	SCK	D52	PB1
	SRAM_CS	D12	PB6
4 Wire RTD	MISO	D50	PB3
	MOSI	D51	PB2
	SCK	D52	PB1
	4 Wire RTD_CS	D33	PC4
	DRDY	D34	PC3



K Type 1	MISO	D50	PB3
	SCK	D52	PB1
	K Type1_CS	D36	PC1
K Type 2	MISO	D50	PB3
	SCK	D52	PB1
	K Type2_CS	D35	PC2
FT230X-USB	TXD0	D1	PE1
	RXD0	D0	PE0
FRAM	SCL	D21	PD0
	SDA	D20	PD1
RTC	SCL	D21	PD0
	SDA	D20	PD1
RDL Bus			
ISP/IO expander mode*	PWM(INT)	D3	PE5
	RST/G*	RST	RESET
	RX3	D15	PJ0
	TX3	D14	PJ1
	SDA	D20	PD1
	SCL	D21	PD0
	MISO	D50	PB3
	MOSI	D51	PB2
	SCK	D52	PB1
	PWM	D10	PB4
Status LED	PWR	5V	5V
	STAT	D13	PB7
	FLT	D49	PL0

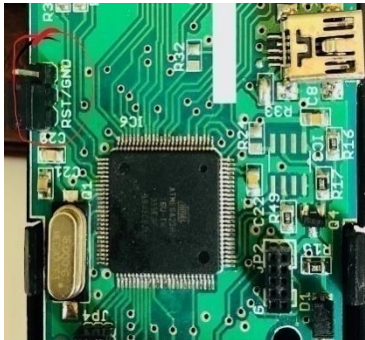
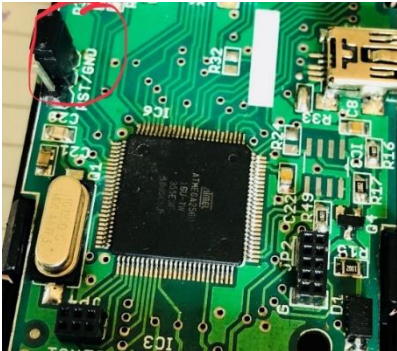

***Note: ISP/IO expander selection modeset the jumpers as shown in the figure.**

ISP Mode selection	I/O expander mode selection
	

8. Programming IDE

The hardware supports various Open Source Programming IDE including Arduino IDE, Atmel Studio and Arduino Compatible Compiler for LabView. For more information on this follow “Open Source Programming IDE” section of the following link.

<https://researchdesignlab.com/indino-4-0.html>

9. Product Specification

9.1 Digital Input

Specification

- Channels: 8
- Input Voltage: 0-24V
 - Logic High: >11V
 - Logic Low: <3V
- Isolation : 3750 VRMS
- Supports Inverted DI Status
- Supported Connection: Dry and Wet both
- Maximum Frequency : 200Hz-38kHz



Functional Diagram

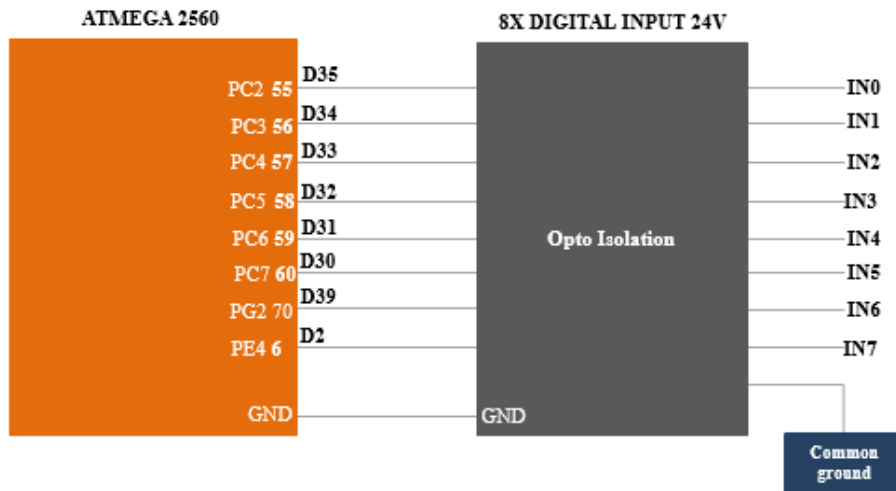

Application Wiring

DRY CONNECTION

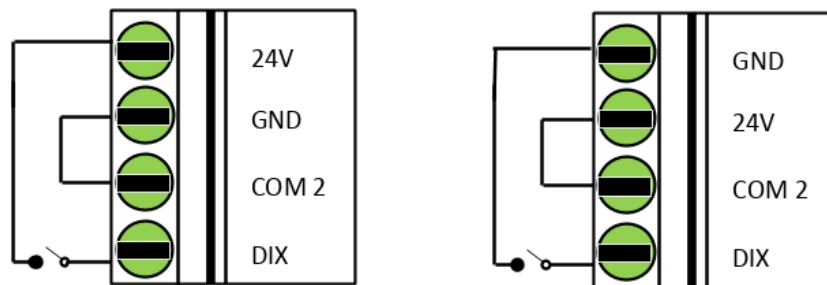



WET CONTACT



TLC/CMOS

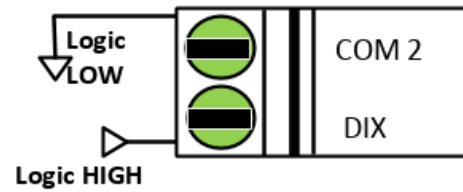
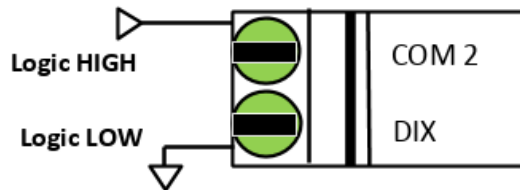

NPN OUTPUT

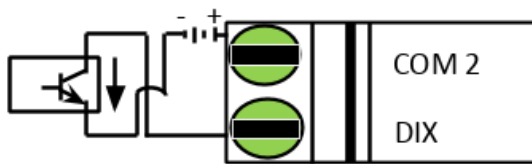

PNP OUTPUT

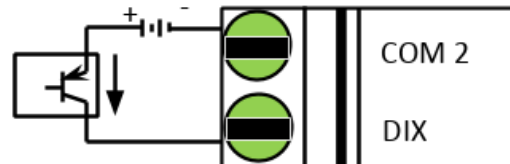

Use Case

1. Measuring Frequency

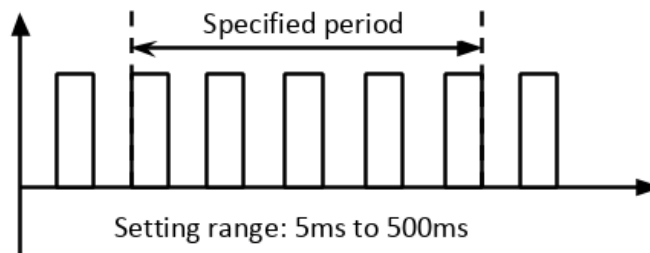

Example Code

You may look into the following link for example on reading a digital pin.

<https://researchdesignlab.com/indino-4-0.html>



9.2 Digital Output

Specification

- Channels: 3
- Open Collector
- Isolation : 3750 VRMS
- Absolute maximum voltage :28V, Current :1000mA
- Cut-Off Frequency : maximum 3KHz

Functional Diagram

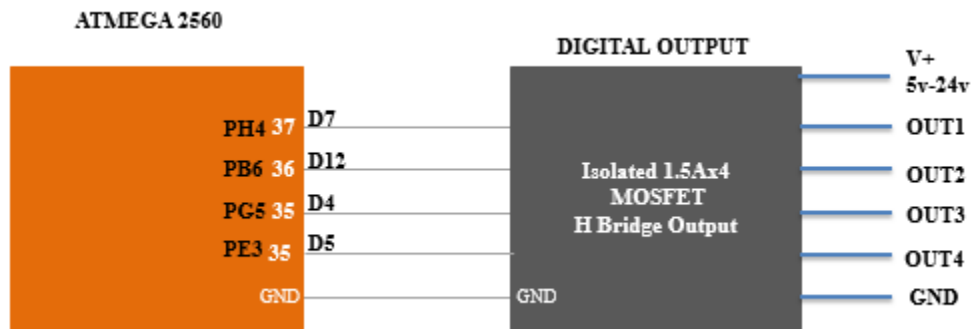

Application:

1. Motion Control

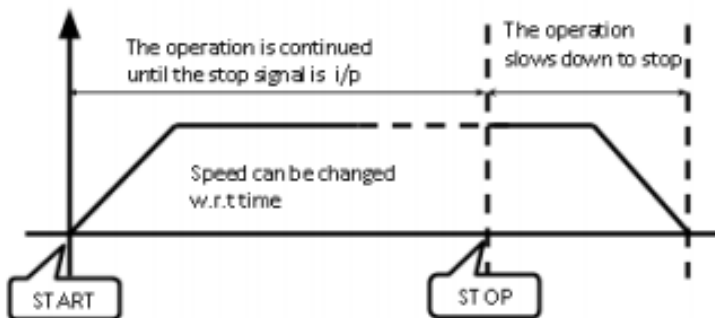

2. Acceleration and Deceleration

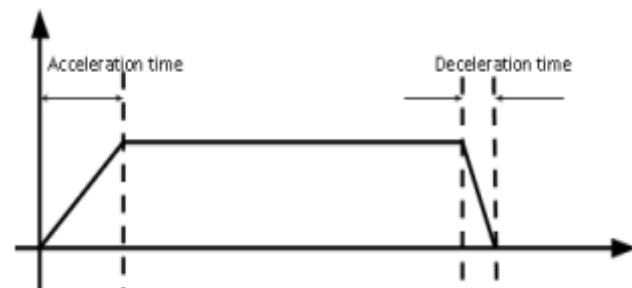



3. Jog Operation and Trapezoidal Control Operation

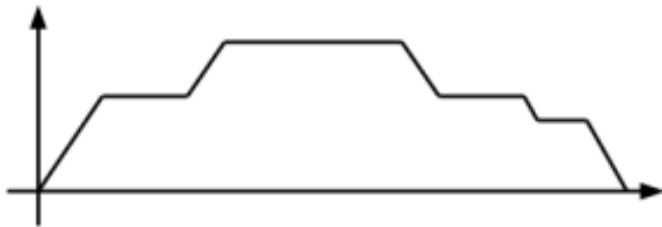

The speed can be freely changed until the operation starts to decelerate to stop

Application Wiring

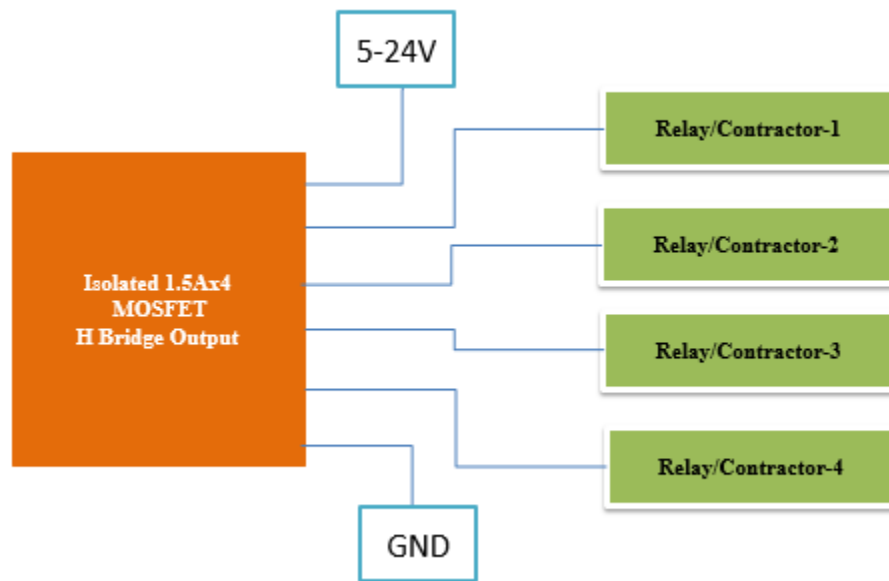

Example Code

Refer: <https://researchdesignlab.com/indino-4-0.html>



9.3 SD Card

Specification

- SPI Serial Interface
- Supports Fat File system

Functional Diagram

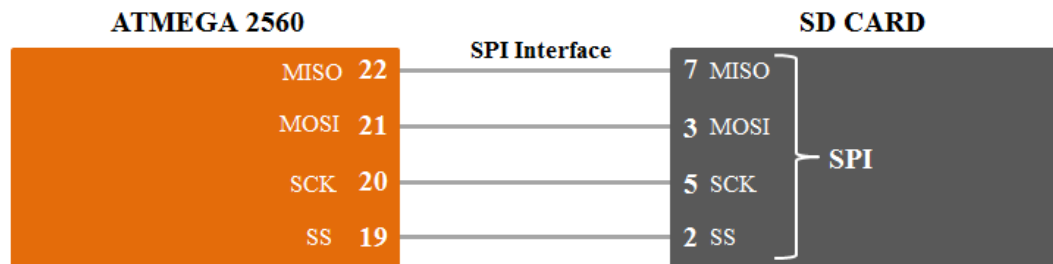

Example Code

You may look into the following link for example on SD Card.

<https://researchdesignlab.com/indino-4-0.html>

9.4 RTC

Specification

- DS1307 with I2C Serial Interface
- Counts Seconds, Minutes, Hours, Date, Month, Day, and Year with Leap-Year Compensation.
- 56-Byte, Battery-Backed, NV RAM for Data Storage
- Consumes <500nA in Battery Backup Mode with Oscillator Running

Functional Diagram

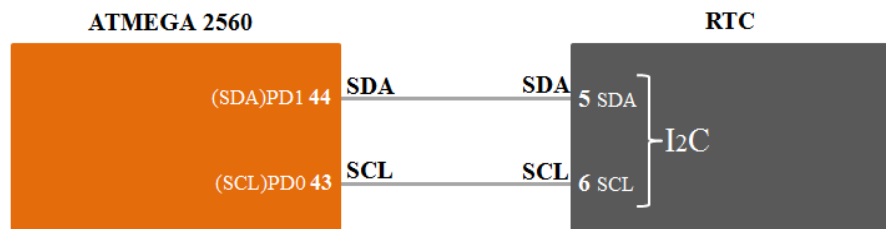

Example Code

www.researchdesignlab.com



You may look into the following link for example code on RTC.

<https://researchdesignlab.com/indino-4-0.html>

9.5 FRAM

FRAM is specifically used for applications such as production counting, production rejection where variable subjected to continuous write cycle

Specification

- MB85RC256V, I2C compatible with Bit configuration : 32,768 words × 8 bits
- Operating frequency : 1 MHz (Max)
- Read/write endurance : 1012 times / byte
- Number of write cycles: 100 Trillion times
- Operating power supply voltage : 2.7V to 5.5V, current 200 μ A
- Data Retention: 10 years (+85°C), 95 years (+55°C), over 200 years (+35°C).

Functional Diagram

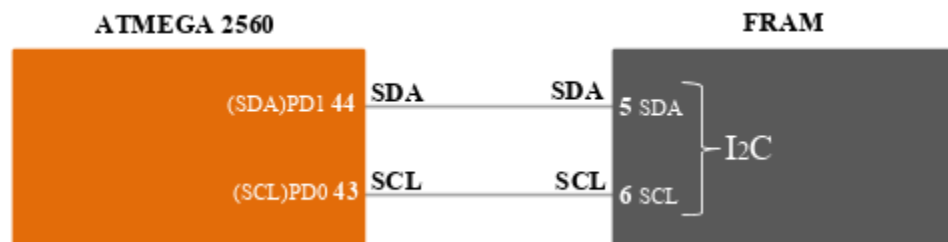

Example Code

You may look into the following link for example on RTC

<https://researchdesignlab.com/indino-4-0.html>

9.6 PWDT (Physical Watch Dog Timer)

External physical watchdog is connected along with inbuilt watchdog timer.

There are many instances where we need to set watch dog time for more than 8 seconds (typically bulk file upload takes in minutes). As inbuilt WDT is limited to maximum of 8Sec, we have gone a step further to support watch dog time up to 3 minutes.



If you do not required PWDT then we can disable it by disabling Enable pin

Note: User must program PWDT to refresh before the timer (3 min) expires.

Specification

- PWDT supports up to 3minutes.
- PIC12F1840 used for PWDT
- Refresh time : 1 pulse in every 3 minutes
- Operating temperature range: –40 to 125 °C

Functional Diagram

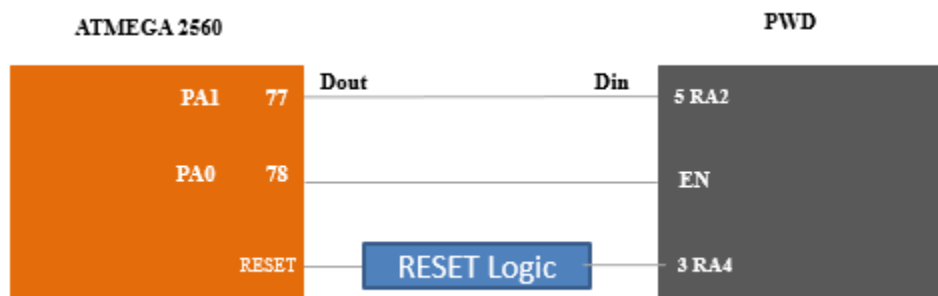

Example Code

You may look into the following link for examples on watchdog timer.

<https://researchdesignlab.com/indino-4-0.html>

9.7. Flash

Flash is specifically used for embedded server.

- Family of SPI Flash memories
- Highest performance serial flash
- Efficient “Continuous Read” OPI mode
- Low power and wide Temperature range
- Flexible architecture with 4KB sectors
- Advanced security feature
- Space Efficient packaging



Functional Diagram

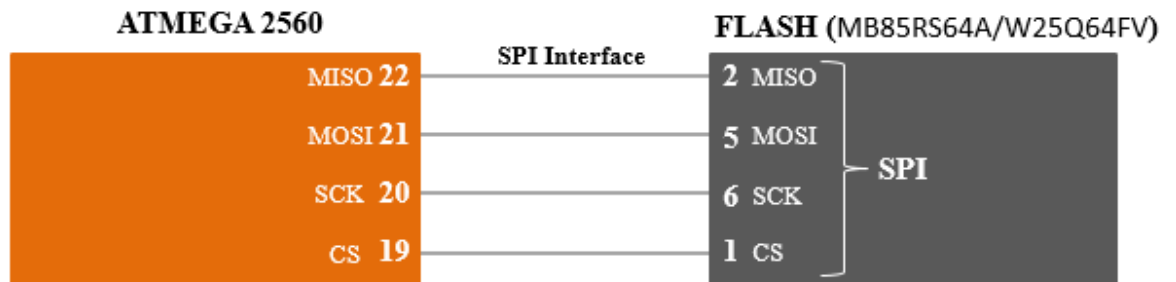

Example Code

You may look into the following link for example on how to use flash.

<https://researchdesignlab.com/indino-4-0.html>

9.8. ESP32

This is Add-On pluggable module. One among ESP32 is comes with the product. For more details on this, look into [Order Information Table](#).

This is specifically used for wireless connectivity with existing infrastructure.

Functional Diagram

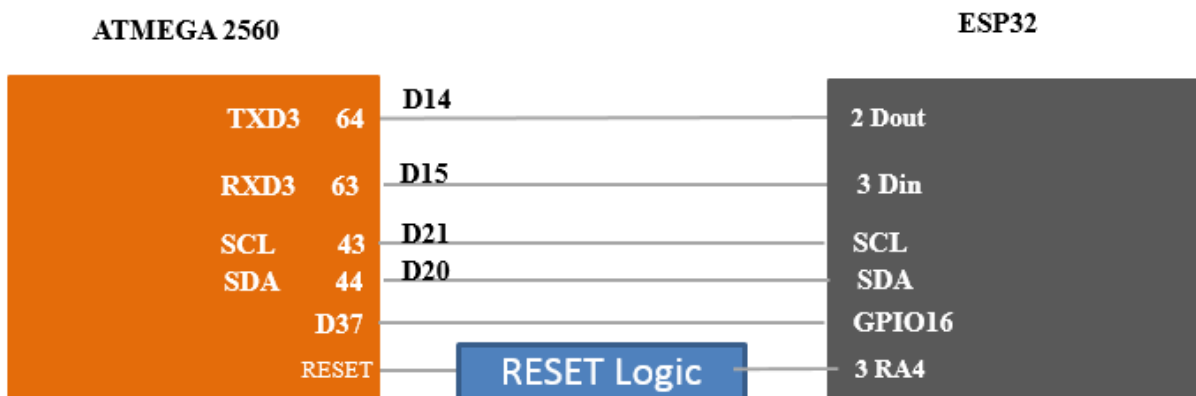



Use Case

Interfacing Industrial Data Logger with Wi-Fi (ESP32)

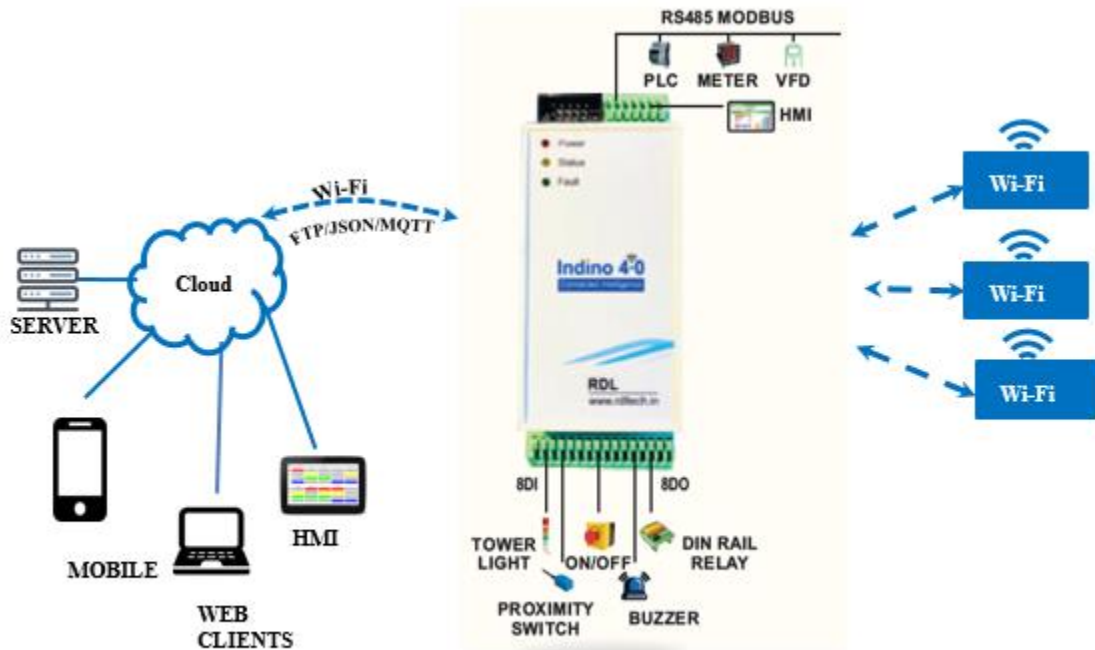

Example Code

You may look into the following link for examples on esp8266.

<https://researchdesignlab.com/indino-4-0.html>

9.9. RS485 Modbus

- Modbus is an Industrial standard serial communication protocol.
- Open protocol
- Information is stored in the Slave device in four different tables.
Two tables store on/off discrete values (coils) and two store numerical values (registers). The coils and registers each have a read-only table and read-write table.
- Each table has 9999 values.
Each coil or contact is 1 bit and assigned a data address between 0000-270E.
Each register is 1 word = 16 bits = 2 bytes and also has data address between 0000 and 270E.
- Supported Functions are



- Coils
- Discrete inputs
- Input Registers
- Holding Registers.

Specification

- o LTC485 IC.
- o Supports slave address up to 32.
- o Supports Modbus protocol with RTU and ASCII formats.
- o Configurable baud rate from 4800 to 115200.
- o Configurable packet format (data bits, parity bit, stop bits)

Functional Diagram

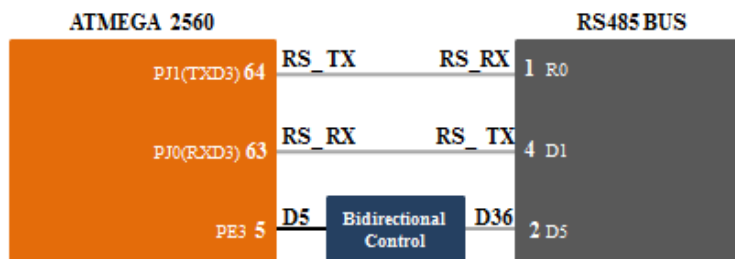



Use Case



Example Code

You may look into the following link for examples on Modbus examples.

<https://researchdesignlab.com/indino-4-0.html>

9.10. RS232

Used for programming the board. When in user mode, the port could be used for data communication.



Functional Diagram

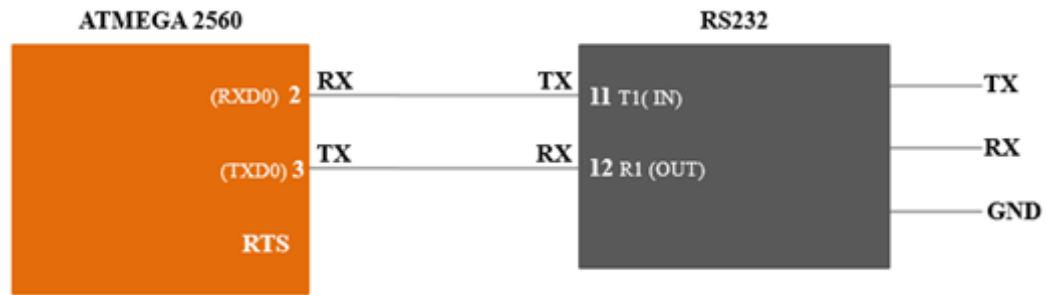

FT232:

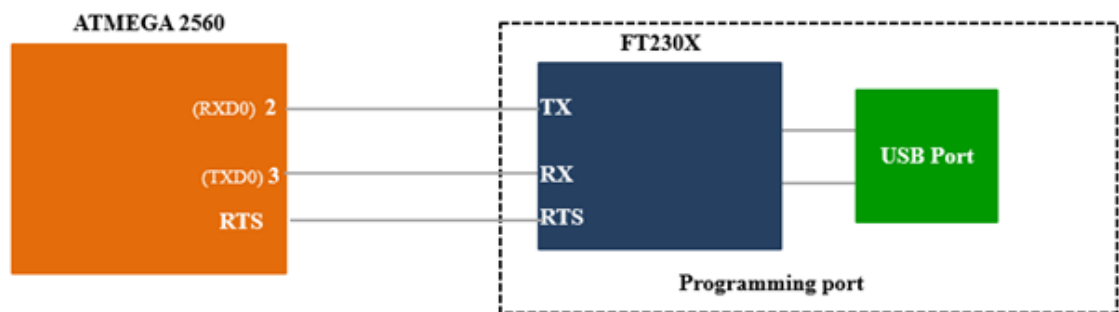

Example Code

You may look into the following link for examples on FT232/MAX232 serial communication.

<https://researchdesignlab.com/indino-4-0.html>



9.11. Status LED Display

Status LED's can be programmed as per used needs for visual indication of an event.

Refer [Digital Output Section](#)

Functional Diagram

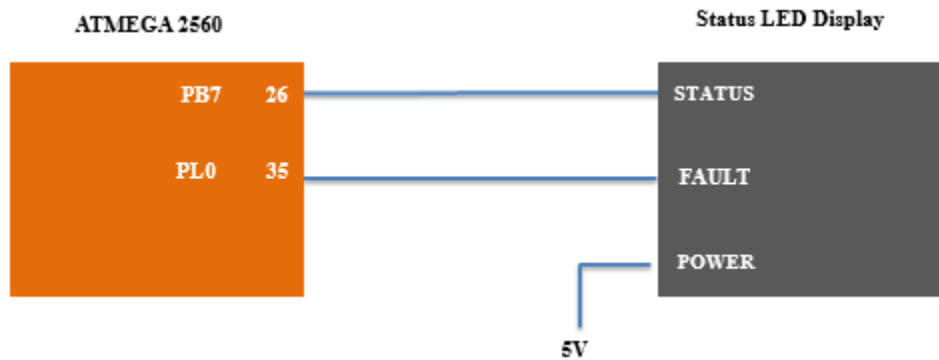

Example Code

You may look into the following link for more details on programming LED pins.

<https://researchdesignlab.com/indino-4-0.html>

9.12. RDL BUS

Specification

- Extend I/O pins for communicating with external devices.
- Extends SPI pins, I2C pins, UART pins and Digital I/O pins.



Functional Diagram

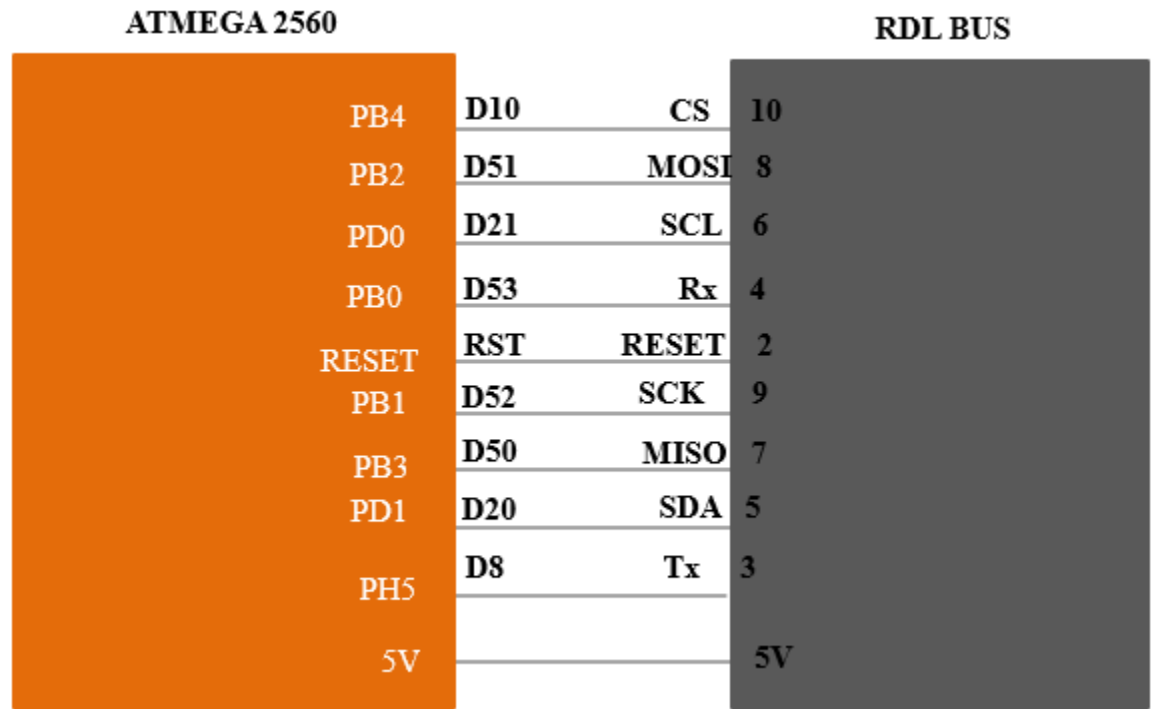

Application Wiring

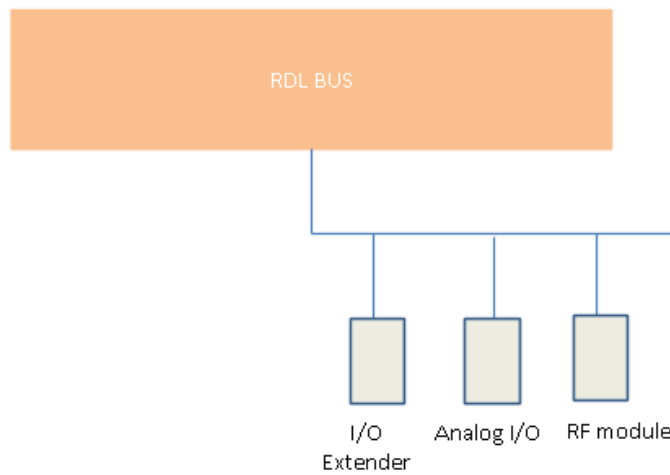



10. Interfacing Indino with Raspberry

Indino can easily interface with Raspberry Pi with all industrial connected sensors and drives with given open source API via following below given interfacing methods. For more details look into the open source API manual.

10.1. With SPI/I2C/UART

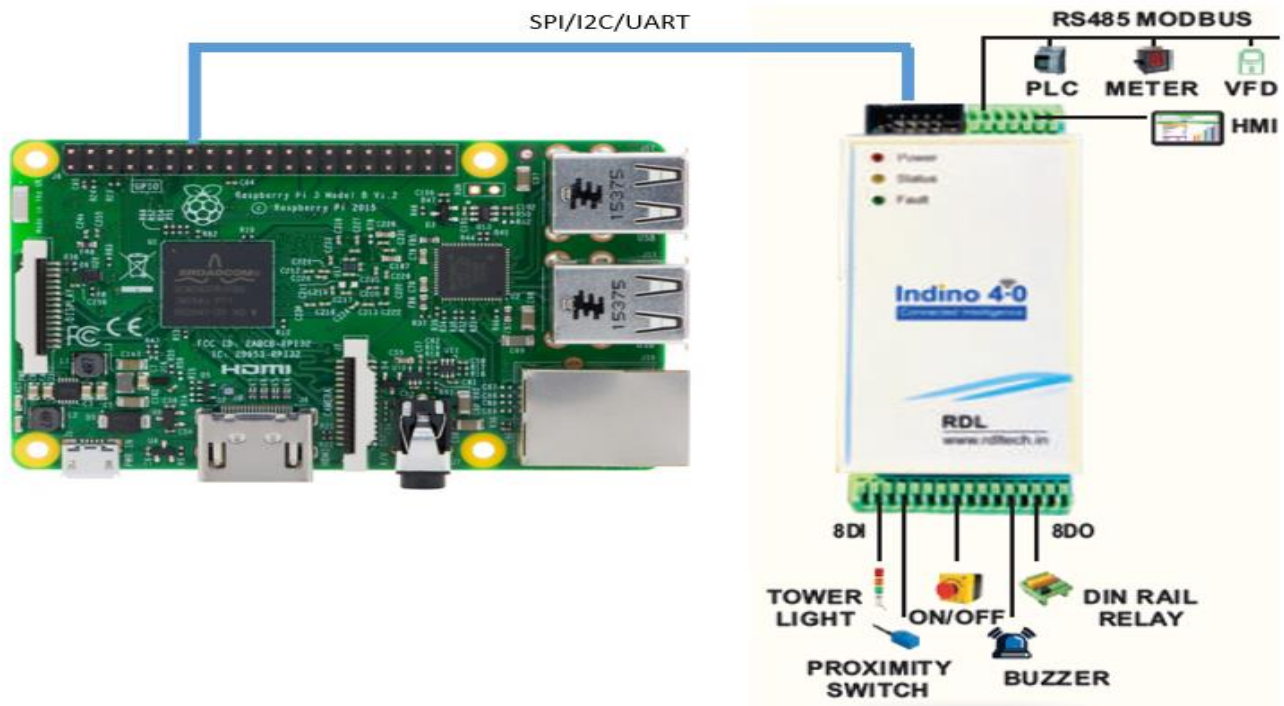

10.2 Interfacing via Wi-Fi and BLE

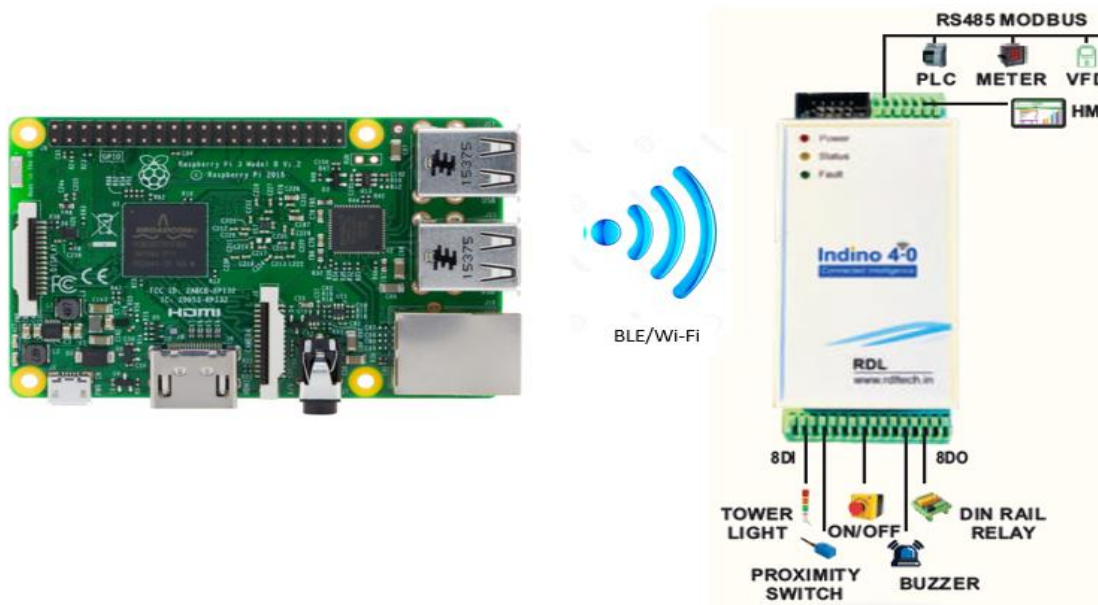



10.3 Interfacing via USB

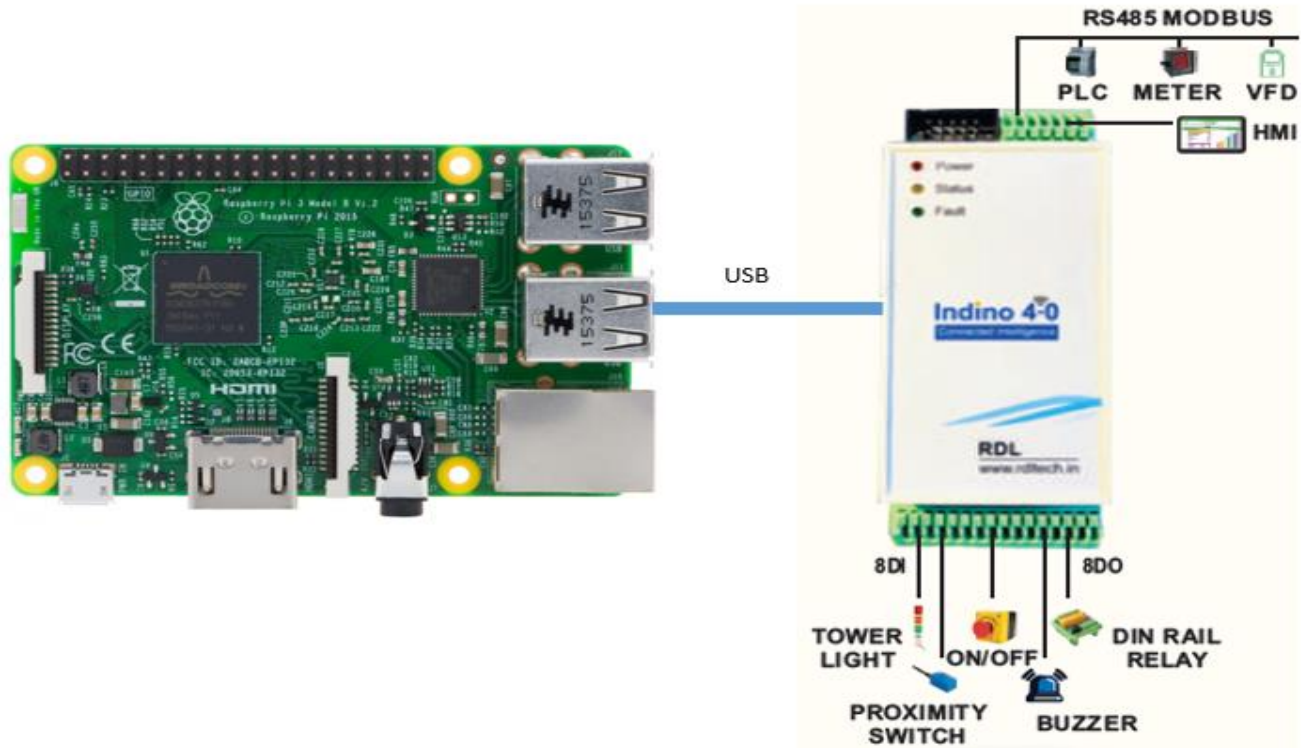

10.4. Interfacing via Ethernet

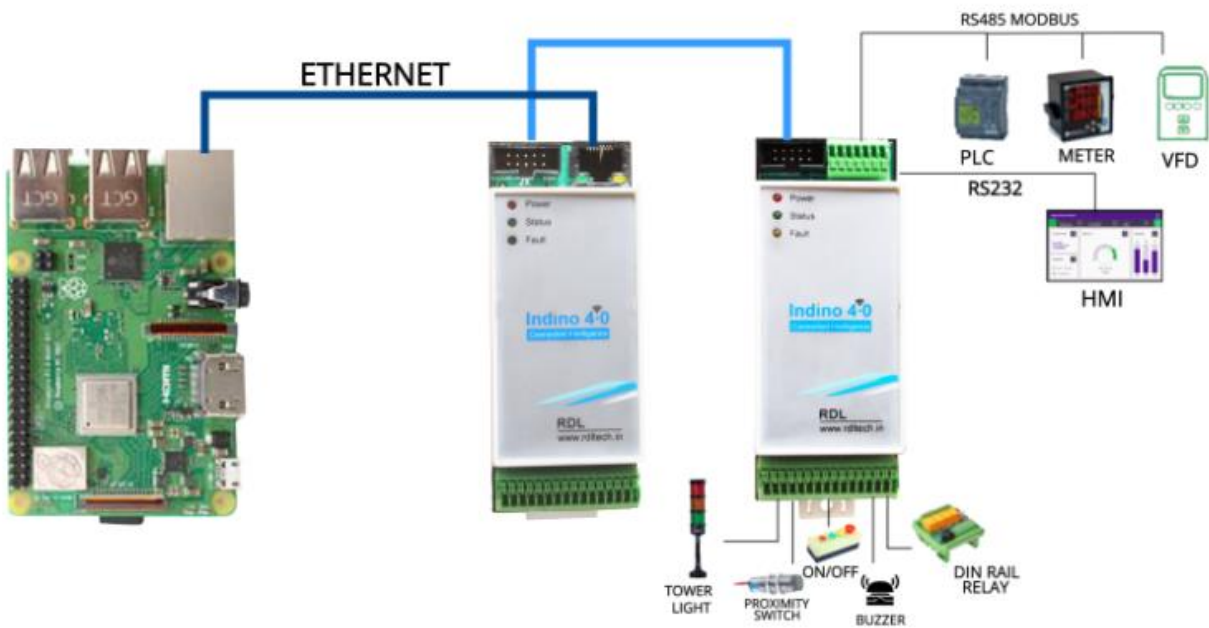



11. Interfacing Indino with Intel NUC:

Indino can easily interface with Intel NUC with all industrial connected sensors and drives with given open source API via following below given interfacing methods. For more details look into the open source API manual.

11.1 Interfacing via USB

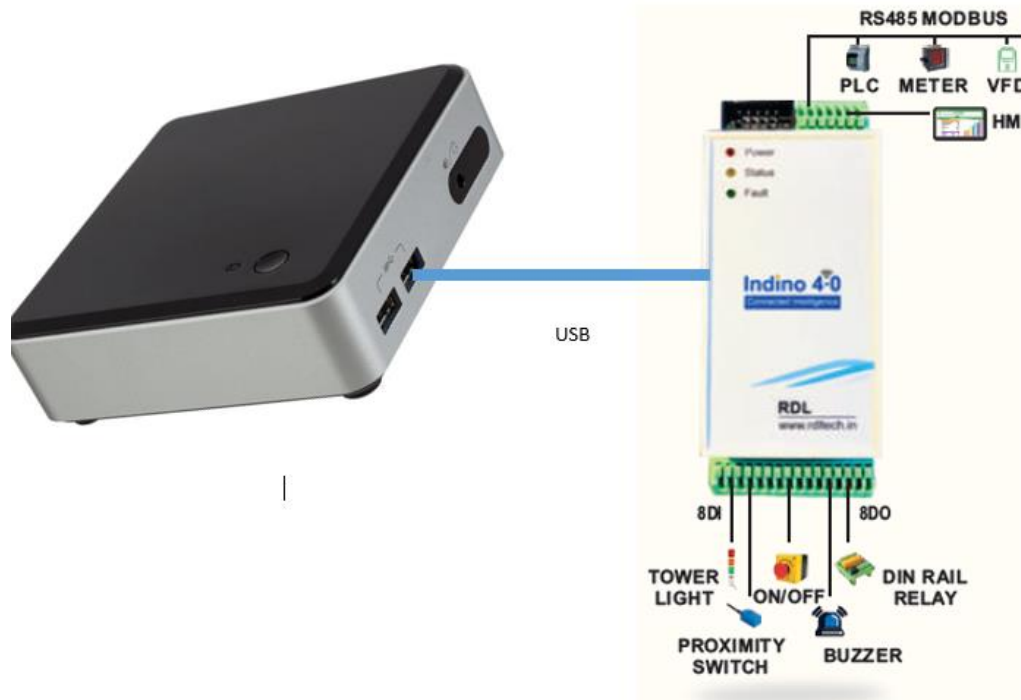

11.2 Interfacing via Wi-Fi/BLE





11.3 Using Ethernet Port

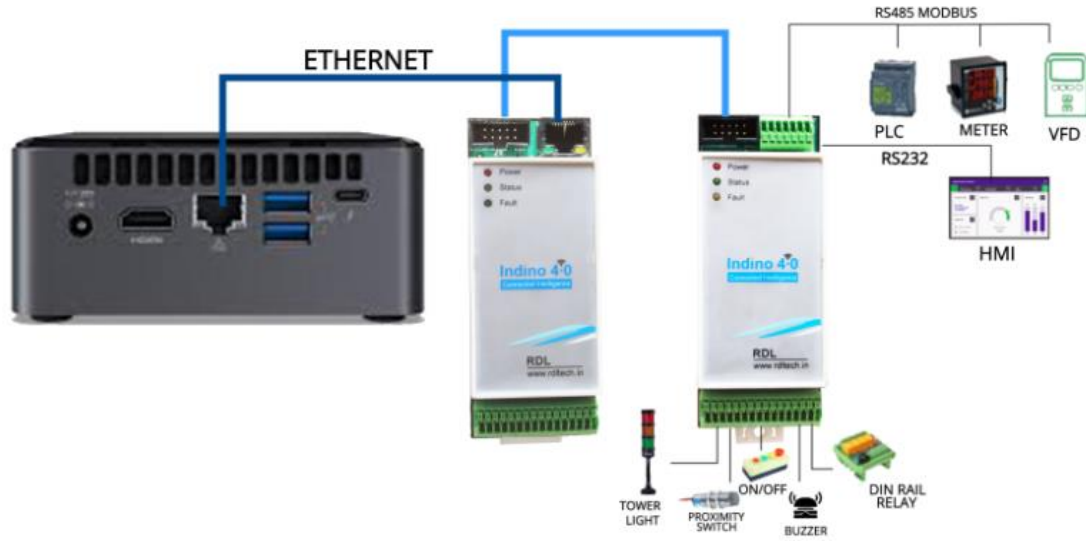



12. Interfacing Indino with Android Tab/Mobile Phone:

Indino can easily interface with Android Tab/Mobile phone with all industrial connected sensors and drives with given open source API via following below given interfacing methods. For more details look into the open source API manual.

12.1 Interfacing via OTG

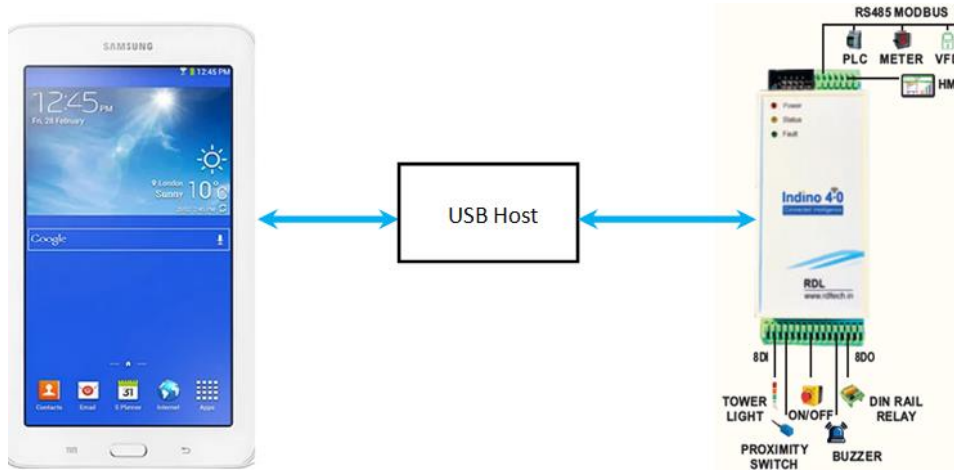

12.2 Interfacing via Wi-Fi/BLE





13. Interfacing Indino with Beaglebone:

Indino can easily interface with Beaglebone with all industrial connected sensors and drives with given open source API via following below given interfacing methods. For more details look into the open source API manual.

13.1 With SPI/I2C/UART

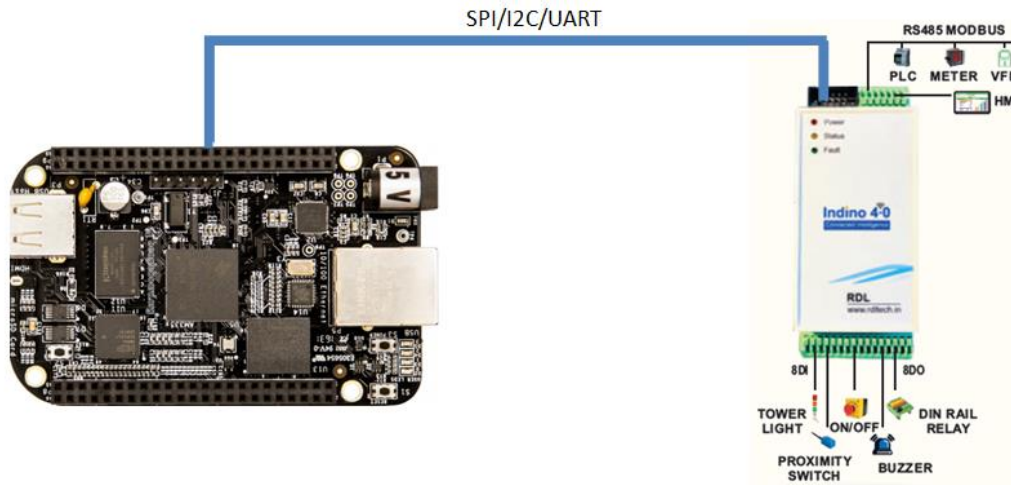

13.2 Interfacing via Wi-Fi and BLE





13.3 Interfacing via USB

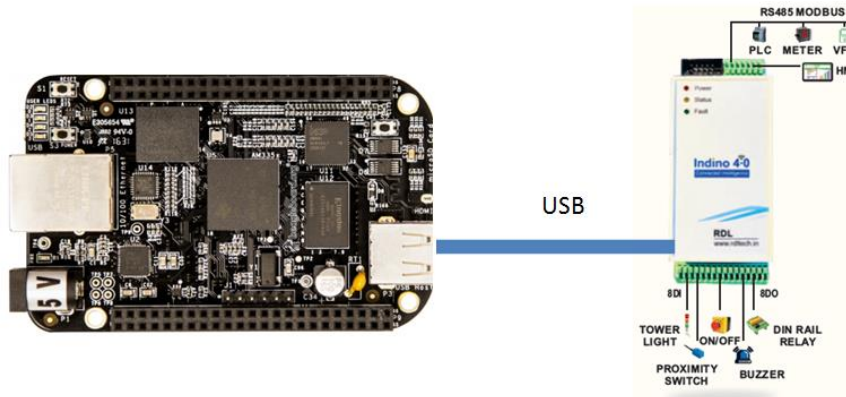

13.4 Interfacing via Ethernet

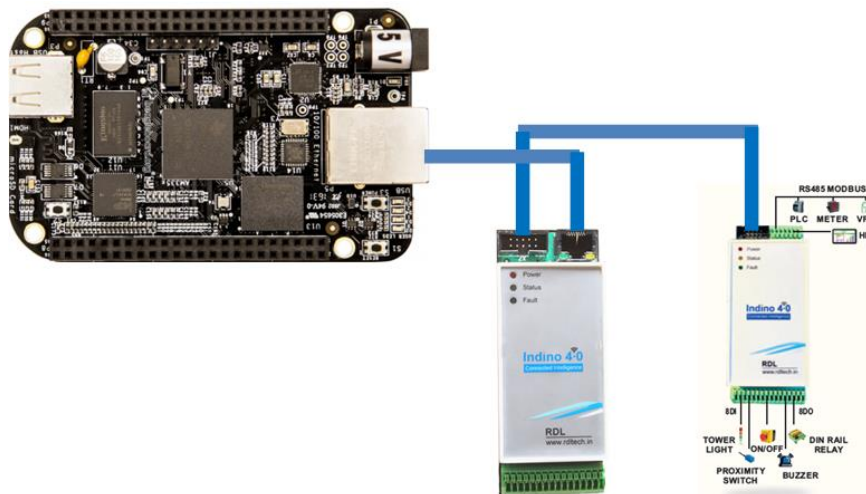



14. Order Information Table

Model	INDINO-8000	INDINO-8005	INDINO-8010	INDINO-8020	INDINO-8021	INDINO-8030	INDINO-8040	INDINO-8050	INDINO-8060
	Digital IO	Digital IO+Wifi	Ethernet IO	Analog IO RTD	Analog IO TC	GPRS IO	LORA IO	XBEE IO	GPRS GPS IO
DI	8	8	6	1	1	8	8	8	8
DO/PWM	4	4	5	4	4	4	4	4	4
ADC/4-20ma	x	x	x	4	4	x	x	x	x
GPRS	x	x	x	x	x	1	x	x	1
Ethernet 10/100mbps	x	x	1	x	x	x	x	x	x
RS485	1	1	x	1	1	1	1	1	1
RS232	1	1	x	1	1	1	1	1	1
RTD input	x	x	x	1	x	x	x	x	x
Thermo couple input	x	x	x	x	2	x	x	x	x
Wi-Fi	x	1	x	x	x	x	x	x	x
Bluetooth	1	1	x	x	x	x	x	x	x
LoRA	x	x	x	x	x	x	1	x	x
XBEE	x	x	x	x	x	x	x	1	x

INDINO S800XX series comes with STM32 as a Co controller where as other series comes with Atmega 2560 as a co controller



15. Mounting and Mechanical Dimensions

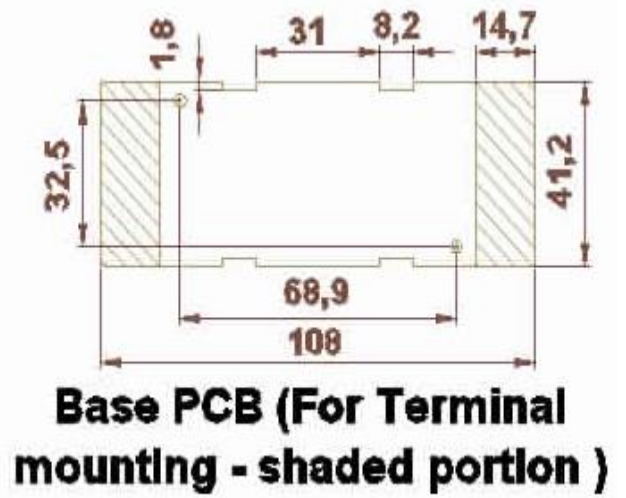
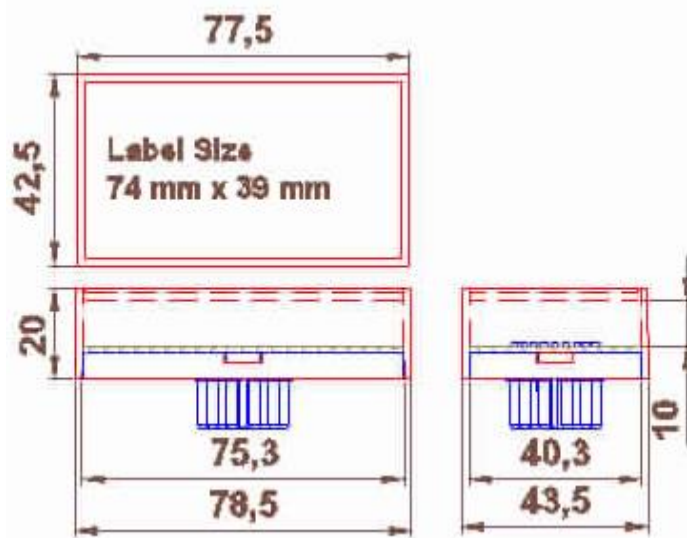

Note:

