

3500 SERIES
 50-125 GALLON OIL RESERVE
 ELEVATOR VAULT

General Notes: 1. Unit comes with interior piping installed.
 2. Inflow section of unit must be filled with at least 14.5" of clear water prior to use.

Specifications: 1. Concrete has design strength of 5,000psi @ 28 days. 2. Steel reinforcement: ASTM A-615, grade 60 ASTM A-497 welded wire fabric. 3. Designed for H2O loading. 4. CI Casting: ASTM A-48, class 30/35.

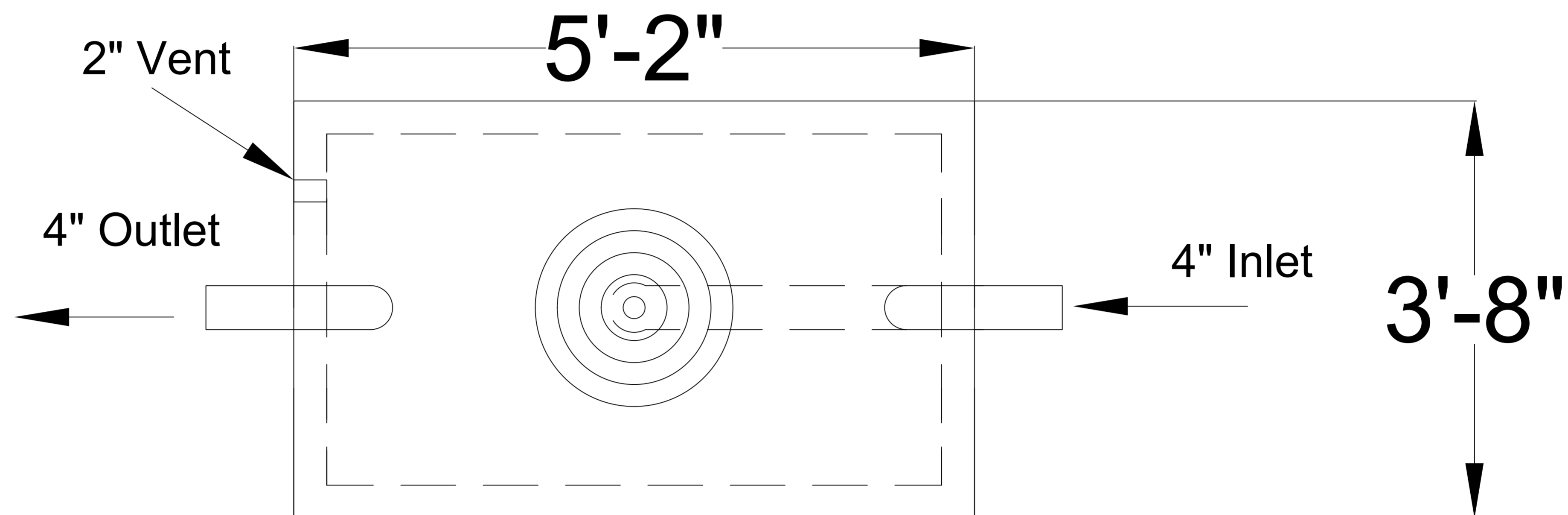

TOP VIEW

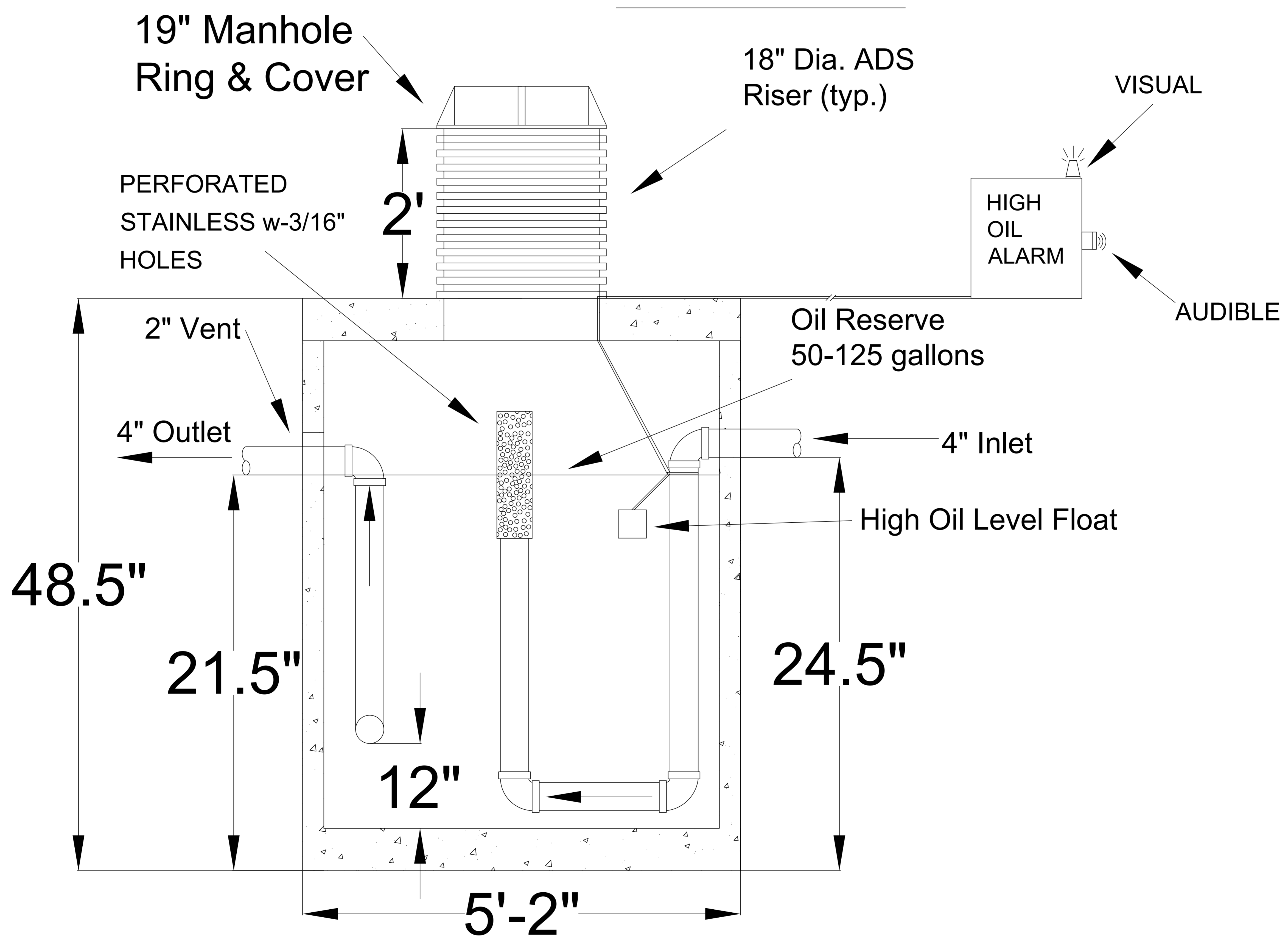

SIDE VIEW

50-125galoilrsvelevatorvault.dwg	APPROVED FOR PRODUCTION	AUTHORIZED BY
	DATE:	PRINT:
	JOB TITLE:	SIGN:
FILE NAME:		