

PRECON PRECAST, LLC
 6868 FM 730 SOUTH
 AZLE, TX 76020

817-448-9718 OFFICE
 817-448-9886 FAX
 frank@preconprecast.com

1

30x30X24 SAMPLE WELL

Specifications: 1. Concrete has design strength of 5,000psi @ 28 days. 2. Steel reinforcement: ASTM A-615, grade 60 ASTM A-497 welded wire fabric. 3. Designed for H2O loading. 4. CI Casting: ASTM A-48, class 30/35.

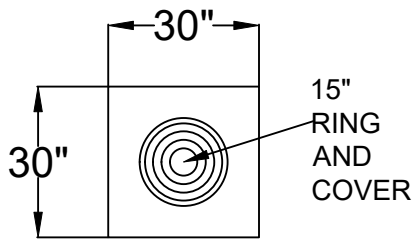

TOP VIEW

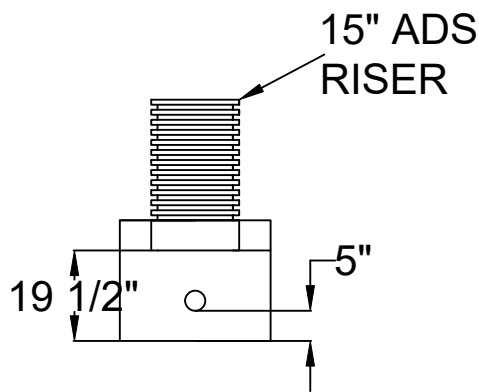

INLET/OUTLET VIEW

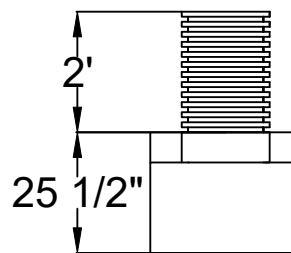

SIDE VIEW

30x30X24samplewell.dwg FILE NAME:	APPROVED FOR PRODUCTION	AUTHORIZED BY
	DATE:	PRINT:
	JOB TITLE:	SIGN: