

PRECON ENVIRONMENTAL PRODUCTS, LLC 817-448-9718 OFFICE  
 6868 FM 730 SOUTH 817-448-9886 FAX  
 AZLE, TX 76020

frank@precon-tx.com  
 www.precon-tx.com

General Notes: 1. Unit comes with interior piping installed.  
 2. Inflow section of unit must be filled with at least 14.5" of clear water prior to use.

Specifications: 1. Concrete has design strength of 5,000psi @ 28 days. 2. Steel reinforcement: ASTM A-615, grade 60 ASTM A-497 welded wire fabric. 3. Designed for H2O loading. 4. CI Casting: ASTM A-48, class 30/35.

1

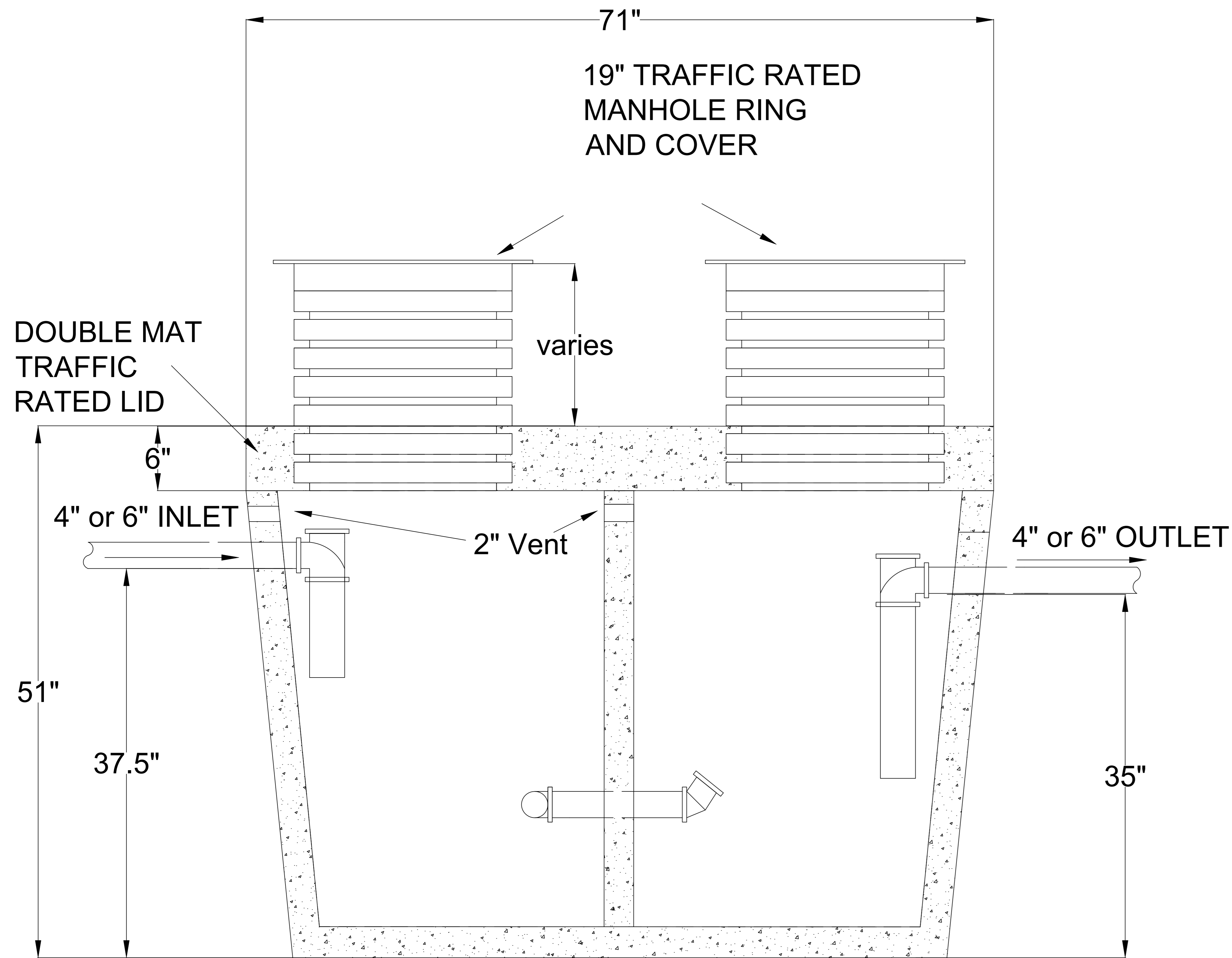

SIDE VIEW

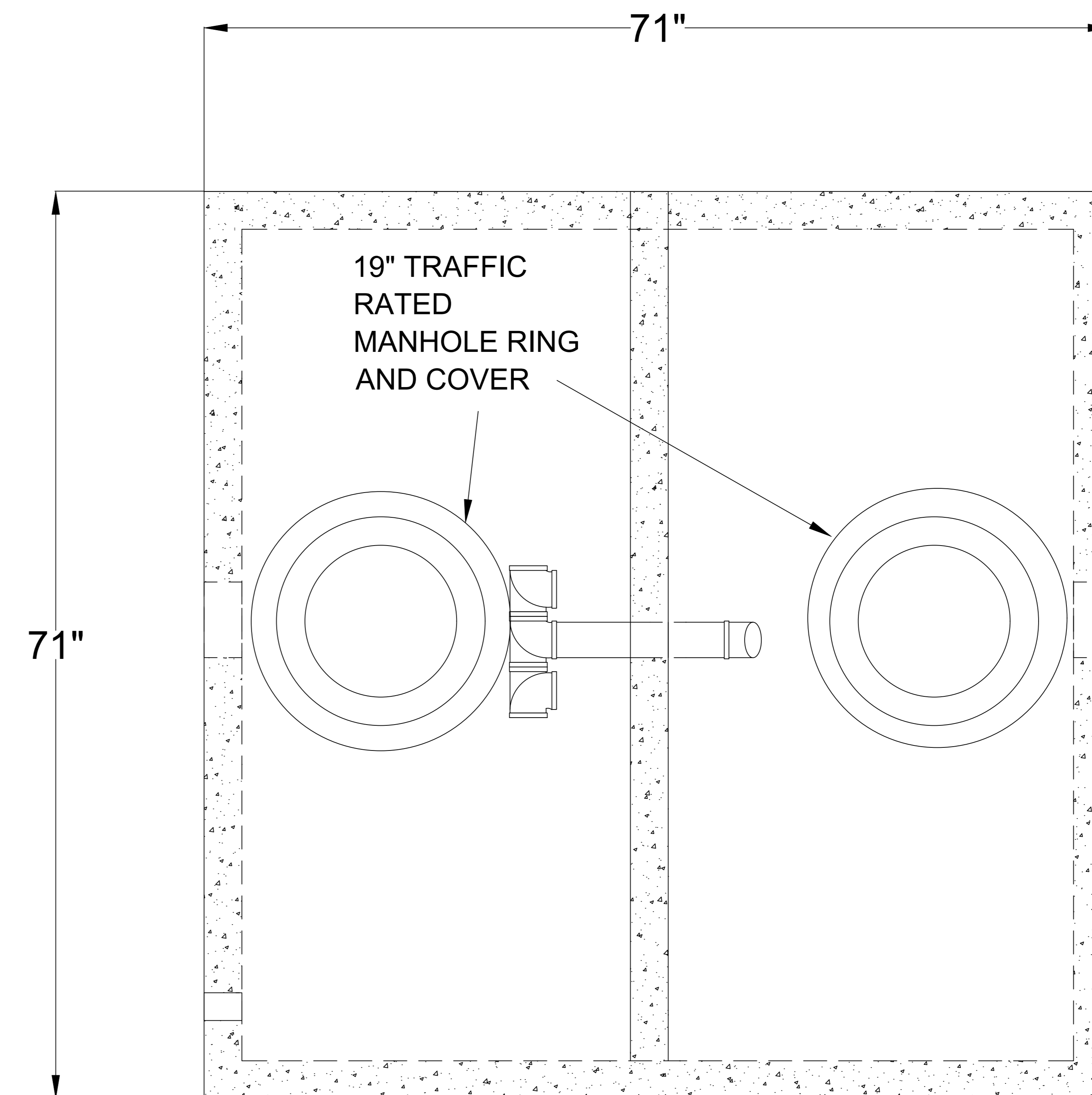

TOP VIEW

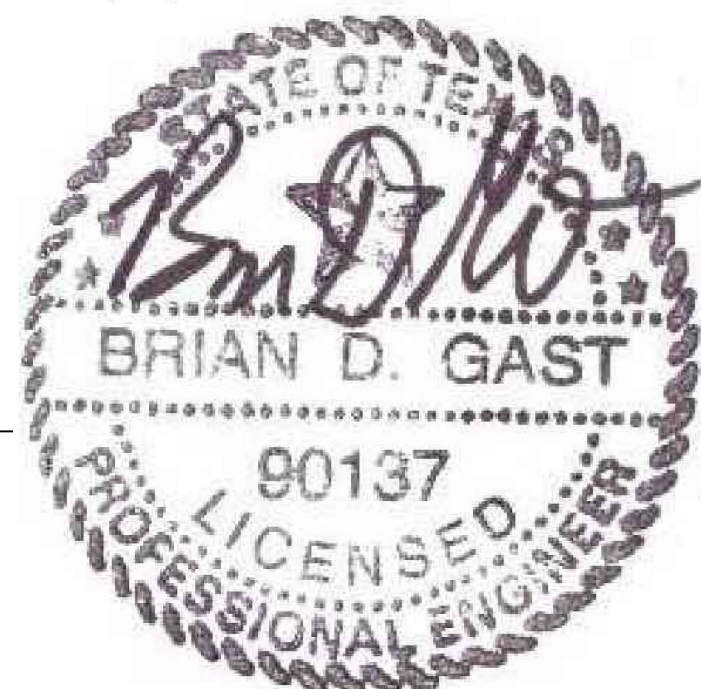

500gallpgt.dwg

FILE NAME:

APPROVED FOR PRODUCTION

DATE:

JOB TITLE:

AUTHORIZED BY

PRINT:

SIGN:

500 GALLON LOW PROFILE  
 GREASE TRAP