

PRECON ENVIRONMENTAL PRODUCTS, LLC
 6868 FM 730 SOUTH
 AZLE, TX 76020

817-448-9718 OFFICE
 817-448-9886 FAX
 frank@precon-tx.com

1

3500 SERIES
 250 GALLON GREASE TRAP
 150 GPM FLOW RATE

General Notes: 1. Unit comes with interior piping installed.
 2. Inflow section of unit must be filled with clear water prior to use.

Specifications: 1. Concrete has design strength of 5,000psi @ 28 days. 2. Steel reinforcement: ASTM A-615, grade 60 ASTM A-497 welded wire fabric. 3. Designed for H2O loading. 4. CI Casting: ASTM A-48, class 30/35.

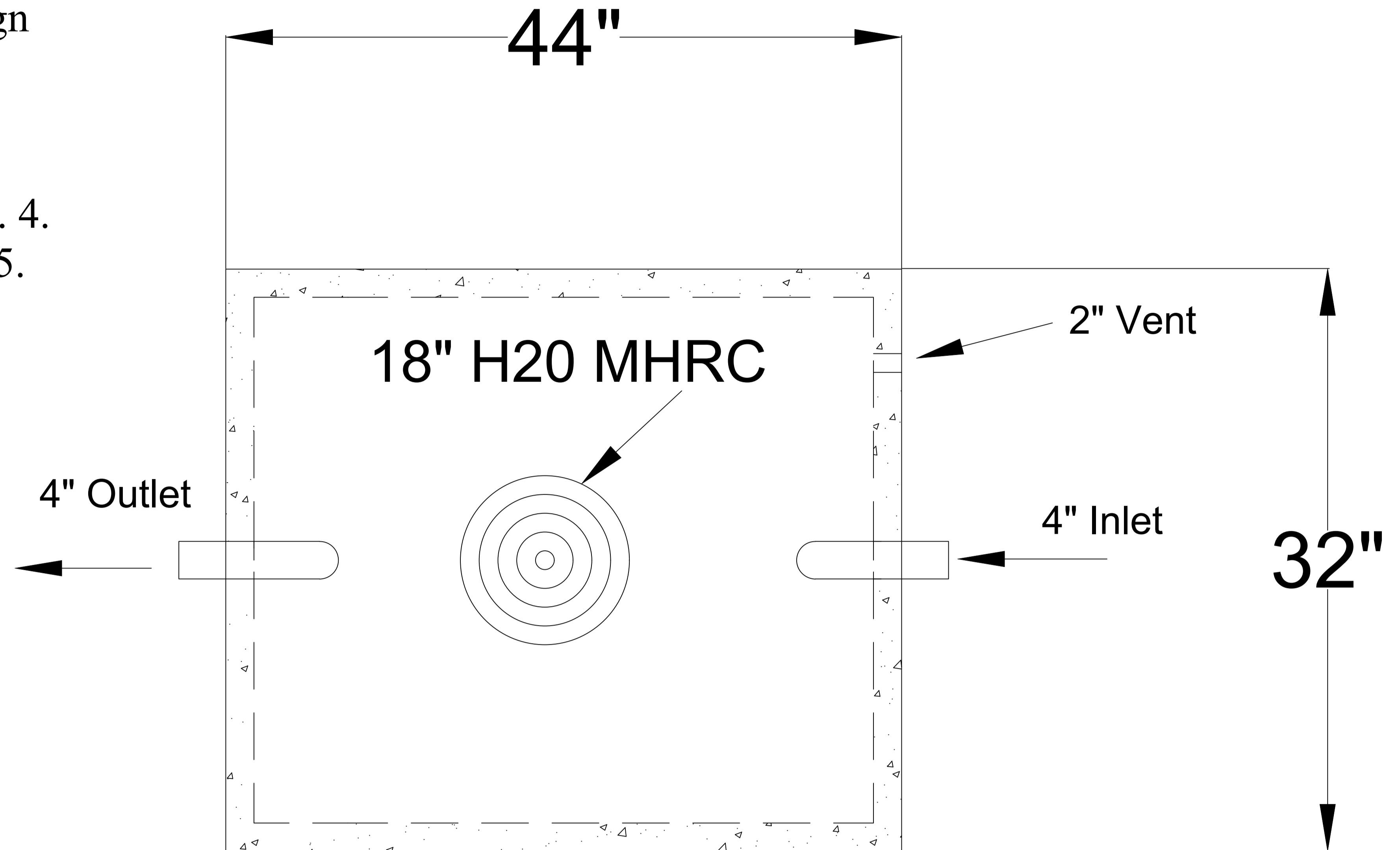

TOP VIEW

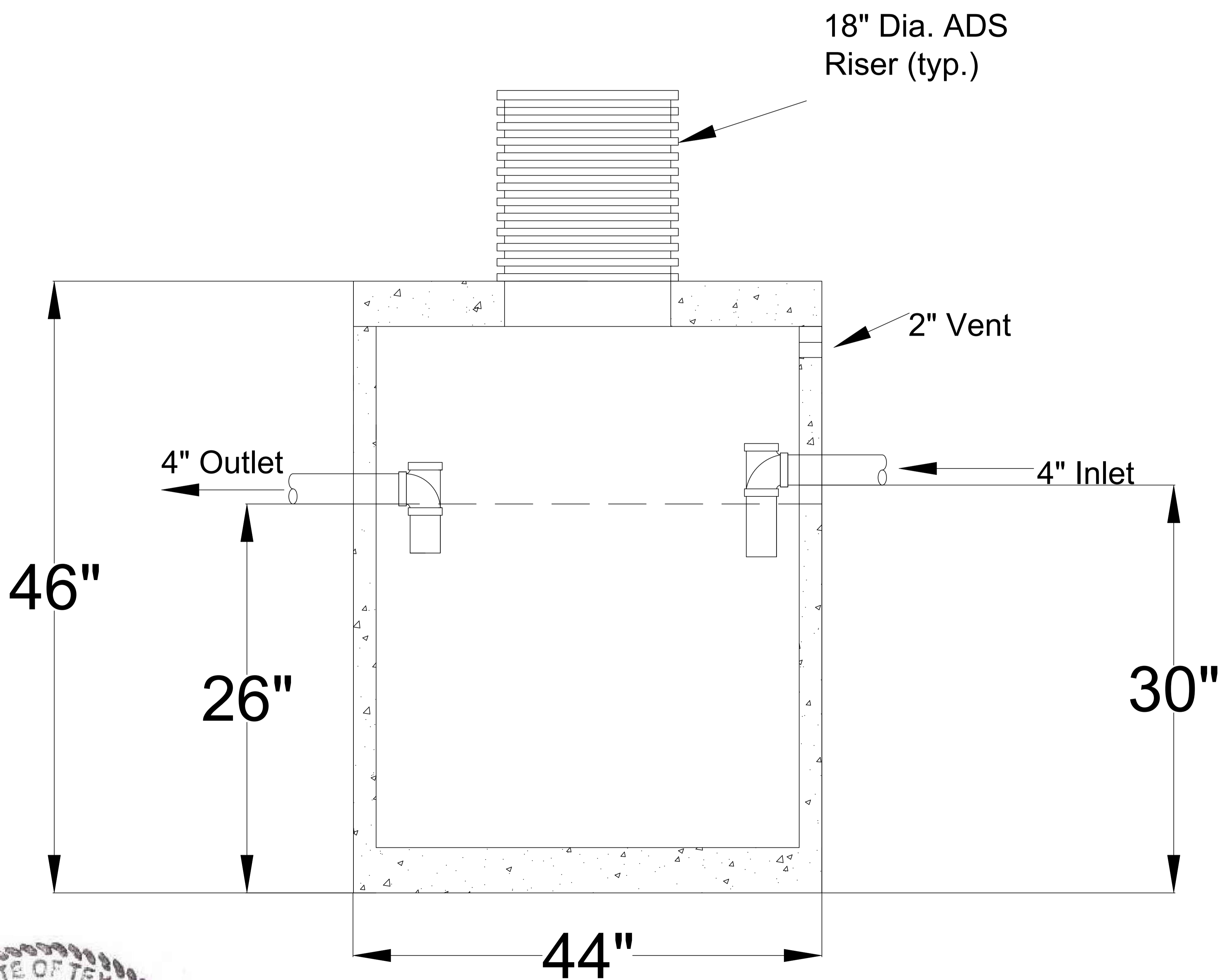

SIDE VIEW

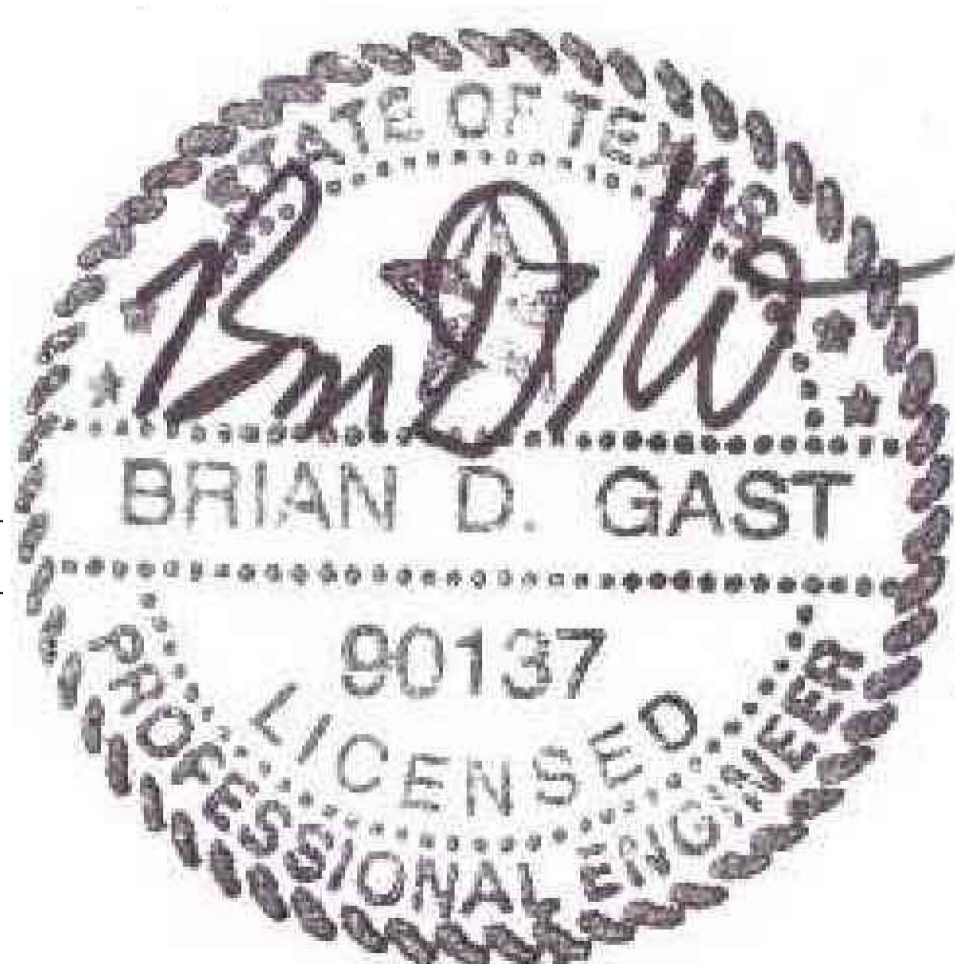

6/14/20
 250galgt.dwg
 FILE NAME:

APPROVED FOR PRODUCTION	AUTHORIZED BY
DATE:	PRINT:
JOB TITLE:	SIGN: