



318-448-1647
Alexandria, LA 71303

3007 North Mac Arthur Drive

To: Grant Parish Hwy Dept QUOTATION NO. 32024-2
200 Main St
318-627-3157 Date: 4/9/2024
Attn: _____
*****Please refer to our quotation number in all correspondence*****

DESCRIPTION:
2024 CASE CX42D MINI EXCAVATOR

- Operating Weight 9,200lbs
- Open Cab Machine
- Rubber Tracks
- Vinyl Seat
- 6 Way Angle Blade
- Travel Alarm
- LED Beacon Light
- Hydraulic Thumb
- 12" Digging Bucket
- 24" Digging Bucket
- Manual Coupler

Sale Price \$71,750.00

Trade Offer for 2004 CASE CX31C \$8,000.00

Pricing firm for Thirty (30) Days. SALE PRICE: \$ 71,750.00 plus tax

Respectfully Submitted, Heath Parker Sales Representative

Buyer's Acceptance, Grant Parish Hwy Dept



ENGINE

Model	Kubota D1803
Emissions Certification	Tier 4 Final
Fuel	Diesel
Cylinders	3
Displacement	111.4 in ³ (1 826 cc)
Fuel injection	Electronic common rail
Gross horsepower – SAE J1995 @ 2300 RPM:	43.3 hp (32.3 kW)
Maximum Engine Torque @ 1600 RPM:	110.6 lb ft (150 Nm)
Minimum RPM	1,000
Maximum RPM	2,400
Cooling	Liquid
Cooling Fan:	Variable Speed Hydraulic cooling fan w/ reverse function

DRIVETRAIN

Travel speeds – 2-speed travel w/ auto-shift:	
1st	1.6 mph (2.6 kph)
2nd	2.8 mph (4.5 kph)
Maximum traction force	9,577 lbf (42.6 kN)
Gradeability	30° (60%)
Ground pressure:	
Canopy	4.1 psi (0.29 kgf/cm ²)
Cab	4.3 psi (0.3 kgf/cm ²)

ELECTRICAL

Voltage	12 Volts
Alternator rating	70 amp
Battery	1 x 12 V x 74 Ah

OPERATOR ENVIRONMENT

ROPS/FOPS Four Post Canopy: Adjustable Vinyl mechanical suspension seat w/ automatic weight control; ROPS/FOPS Enclosed Cab: Overhead opening front window, Sliding right side window, Heat & A/C – automatic climate control or manual w/ 6 adjustable vents, Radio & Speakers, Adjustable Cloth mechanical suspension seat w/ automatic weight control, Front wiper and washer, Hammer for emergency exit, Rear view mirrors – left and right; Tipping cab/canopy for servicing; Height adjustable arm rests; Controls cut-out lever (safety lever); Auto-idle/manual idle button; Engine rpm hand dial; 2 in (51 mm) Seat belt; Bottle/cup holder; Keyed locks common w/ starting key; Foot rests; 2- 12V auxiliary socket; USB type power socket 7 in LCD Control Panel; Display Navigation console.

Controls:

Travel Levers; Foldable travel foot pedals; Pilot controlled joysticks for boom, arm, bucket, and swing; Operation joysticks; Blade control lever.

Display includes:

Coolant Temp; Hydraulic Oil Temp; Fuel Level; Machine hours; Time; Climate Control; Engine; RPM; Warning Indicators; Message area; DPF Regeneration request; Function Indicators.

OPERATING WEIGHT

Canopy operating weight:

Short arm	9,259 lb (4 200 kg)
Long arm w/ additional counterweight	9,921 lb (4 500 kg)

Cab operating weight:

Short arm	9,590 lb (4 350 kg)
Long arm w/ additional counterweight	10,251 lb (4 650 kg)

Counterweights:

Standard	110 lb (50 kg)
Additional	617 lb (280 kg)
Additional – heavy	925 lb (420 kg)

NOTE: w/rubber tracks/no quick coupler/bucket/fluids/full of fuel/165 lb operator.

HYDRAULICS

Load Sensing closed center w/ "Flow Sharing" control valve

Pump type	1 Electronic control Load Sensing pump w/ variable flow rate + 1 gear pump
Pump displacement	3.3 + 0.7 in ³ (53.7 + 11.2 cc)
Total flow rate	28.3 + 5.9 gpm (107 + 22.3 L/min)

Operating Pressures:

Boom, bucket, blade, travel motors:

	4,061 psi (280 bar)
Slewing Gear Motor	2,828 psi (195 bar)
Pilot controls	493 psi (34 bar)

Auxiliary flow:

Aux. 1 – 1 or 2-way circuit:	
Max. Flow	18.5 gpm (70 L/min)
Max. Pressure	2,900 psi (200 bar)
Aux. 2 – 2-way circuit:	
Max. Flow	10.6 gpm (40 L/min)
Max. Pressure	4,061 psi (280 bar)
Aux. 3 – 2-way circuit:	
Max. Flow	10.6 gpm (40 L/min)
Max. Pressure	4,061 psi (280 bar)

Swing Motor: Hydraulic drive units w/ axial pistons and hydraulic released brake

Travel Motor: Hydraulic drive units w/ axial pistons, Auto-Shift 2-speed transmission, and hydraulic released parking brake

SERVICE CAPACITIES

Fuel tank	15.9 gal (60 L)
Hydraulic tank:	
Refill capacity	13.2 gal (50 L)
Total system	17.2 gal (65 L)
Cooling system	2.4 gal (9 L)
Engine oil	1.8 gal (7 L)

OTHER SPECIFICATIONS

Swing speed	10.5 RPM
Rubber tracks dimensions	13.8 x 2.2 x 3.5 in (350 x 55 x 88 mm)
Undercarriage:	
Track rollers	1 upper/5 lower each
Boom:	
Swing	71° left/56° right
Length	8 ft 2 in (2.5 m)
Arm:	
Standard length	4 ft 7 in (1.4 m)
Long arm length	5 ft 5 in (1.65 m)
Sound Pressure Internal – ISO6396 – LpA:	
Canopy	81 dBA
Cab	74 dBA
Sound Power External – LwA	96 dBA
Vibrations ISO 2631 – hand	0.98 m/s ²
Vibrations ISO 2631 – whole body	0.45 m/s ²

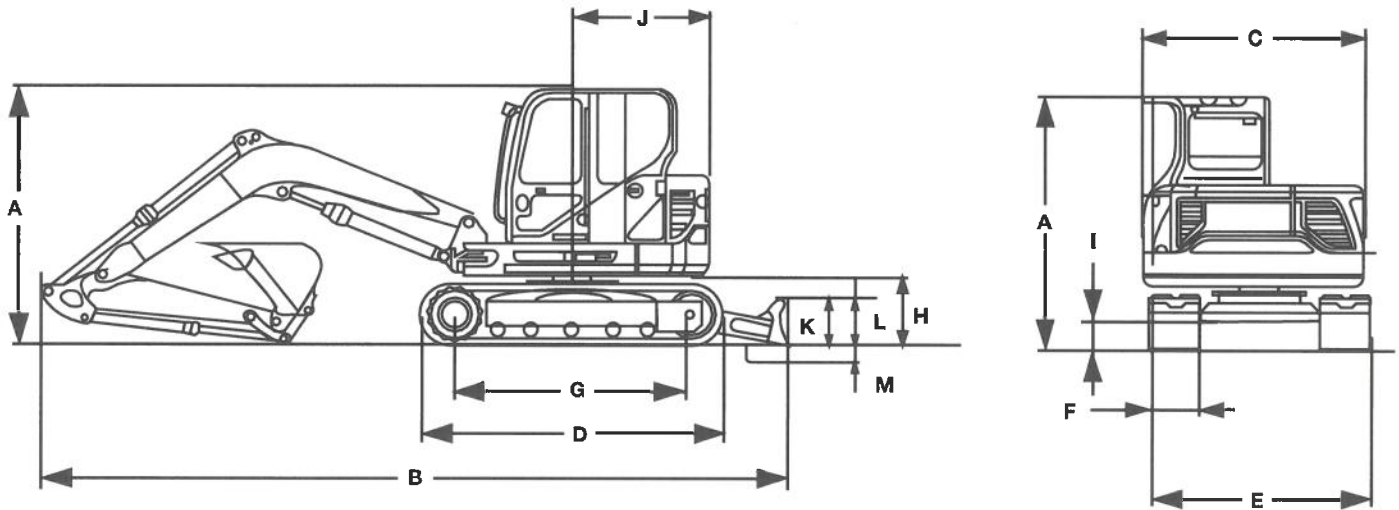

Line drawings are for illustrative purpose only and may not be exact representation of unit.

DIMENSIONS

4 ft 7 in (1.40 m) Arm

A. Overall height	8 ft 3 in (2 510 mm)
B. Overall transport length	17 ft 5 in (5 300 mm)
C. Width of upper structure	5 ft 7 in (1 716 mm)
D. Track overall length	7 ft 5 in (2 260 mm)
E. Track overall width	5 ft 9 in (1 750 mm)
F. Track shoe width	1 ft 2 in (350 mm)
G. Center to center - idler to sprocket	5 ft 11 in (1 810 mm)
H. Upper structure ground clearance	1 ft 10 in (550 mm)
I. Minimum ground clearance	11.4 in (290 mm)
J. Tail swing radius:	
Standard counterweight	2 ft 10 in (875 mm)
Additional counterweight	3 ft 2 in (965 mm)
Additional counterweight - heavy	3 ft 4 in (1 015 mm)
Boom swing	71° left/56° right
Tail swing overhang:	
Standard counterweight	0 in (0 mm)
Additional counterweight	3.5 in (90 mm)
Additional counterweight - heavy	5.5 in (140 mm)

BLADE SPECS

K. Backfill blade height	1 ft 4 in (410 mm)
L. Backfill blade rise above ground	1 ft 3 in (380 mm)
M. Backfill blade dig depth	1 ft 1 in (330 mm)
Backfill blade width	5 ft 9 in (1 750 mm)

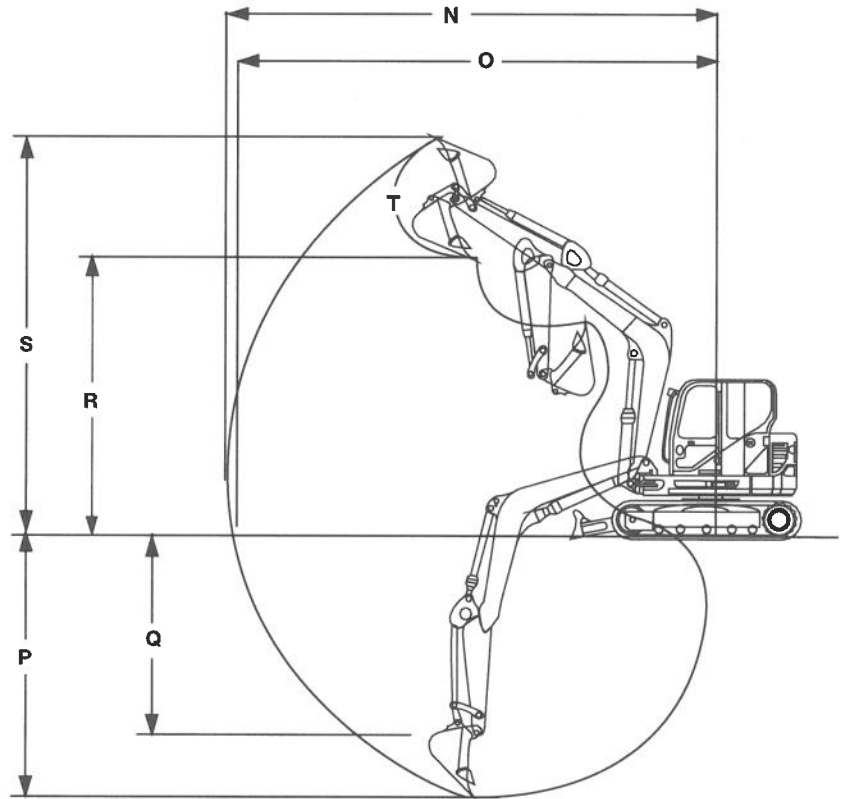

PERFORMANCE SPECS

	4 ft 7 in (1.40 m) Arm	5 ft 5 in (1.65 m) Arm
N. Maximum dig radius	17 ft 9 in (5 400 mm)	18 ft 6 in (5 640 mm)
O. Dig radius at groundline	17 ft 3 in (5 270 mm)	18 ft 1 in (5 515 mm)
P. Maximum dig depth	10 ft 1 in (3 085 mm)	10 ft 11 in (3 335 mm)
Q. Vertical straight wall dig depth	7 ft 10 in (2 380 mm)	8 ft 7 in (2 620 mm)
R. Dump height	12 ft 0 in (3 660 mm)	12 ft 6 in (3 820 mm)
S. Overall reach height	16 ft 5 in (5 010 mm)	17 ft 0 in (5 170 mm)
T. Bucket rotation	195°	195°
Arm digging force - ISO	4,946 lbf (22 kN)	4,406 lbf (19.6 kN)
Bucket digging force - ISO	9,667 lbf (43 kN)	9,667 lbf (43 kN)

LIFT CAPACITIES

8 ft 2 in (2.5 m) Boom, 4 ft 7 in (1.40 m) Arm, Dozer Blade Down Machine equipped with cab, rubber tracks, standard counterweight, without bucket or quick coupler.

Load/Lift Point Height	LOAD RADIUS								MAXIMUM REACH			
	3 ft (1.0 m)		7 ft (2.0 m)		10 ft (3.0 m)		13 ft (4.0 m)		REACH	CAPACITY		
	END	SIDE	END	SIDE	END	SIDE	END	SIDE		@	END	SIDE
+13 ft (4.0 m)										10 ft 10 in (3.29 m)	1,984 lb* (900 kg)*	1,587 lb (720 kg)
+10 ft (3.0 m)								1,984 lb* (900 kg)*	1,146 lb (520 kg)	13 ft 7 in (4.15 m)	2,028 lb* (920 kg)*	1,080 lb (490 kg)
+7 ft (2.0 m)					2,491 lb* (1 130 kg)*	1,742 lb (790 kg)	2,161 lb* (980 kg)*	1,124 lb (510 kg)	15 ft 0 in (4.56 m)	2,116 lb* (960 kg)*	904 lb (410 kg)	
+3 ft (1.0 m)					3,549 lb* (1 610 kg)*	1,587 lb (720 kg)	2,513 lb* (1 140 kg)*	1,058 lb (480 kg)	15 ft 4 in (4.67 m)	2,249 lb* (1 020 kg)*	838 lb (380 kg)	
Groundline			7,937 lb* (3 600 kg)*	2,734 lb (1 240 kg)	4,145 lb* (1 880 kg)*	1,499 lb (680 kg)	2,800 lb* (1 270 kg)*	1,014 lb (460 kg)	14 ft 10 in (4.52 m)	2,403 lb* (1 090 kg)*	860 lb (390 kg)	
-3 ft (-1.0 m)		13,073 lb (5 930 kg)	7,187 lb* (3 260 kg)*	2,756 lb (1 250 kg)	4,079 lb* (1 850 kg)*	1,499 lb (680 kg)	2,668 lb* (1 210 kg)*	1,014 lb (460 kg)	13 ft 4 in (4.06 m)	2,579 lb* (1 170 kg)*	992 lb (450 kg)	
-7 ft (-2.0 m)			5,225 lb* (2 370 kg)*	2,866 lb (1 300 kg)	2,932 lb* (1 330 kg)*	1,565 lb (710 kg)			10 ft 2 in (3.10 m)	2,778 lb* (1 260 kg)*	1,499 lb (680 kg)	

NOTE: Lifting capacity are based on ISO 10567.

Lifting capacity does not exceed 75% of tipping load with the machine on firm, level ground or 87% of full hydraulic capacity. Back of the arm linkage.

*Indicates load limited by hydraulic capacity.

For lift capacities with additional counterweights please see operators manual.

8 ft 2 in (2.5 m) Boom, 5 ft 5 in (1.65 m) Arm, Dozer Blade Down Machine equipped with cab, rubber tracks, additional counterweight, without bucket or quick coupler.

Load/Lift Point Height	LOAD RADIUS								MAXIMUM REACH			
	3 ft (1.0 m)		7 ft (2.0 m)		10 ft (3.0 m)		13 ft (4.0 m)		REACH	CAPACITY		
	END	SIDE	END	SIDE	END	SIDE	END	SIDE		@	END	SIDE
+13 ft (4.0 m)										12 ft 0 in (3.65 m)	1,786 lb* (810 kg)*	1,543 lb (700 kg)
+10 ft (3.0 m)								1,742 lb* (790 kg)*	1,345 lb (610 kg)	14 ft 6 in (4.42 m)	1,852 lb* (840 kg)*	1,124 lb (510 kg)
+7 ft (2.0 m)					2,161 lb* (980 kg)*	2,028 lb (920 kg)	1,962 lb* (890 kg)*	1,301 lb (590 kg)	15 ft 9 in (4.80 m)	1,940 lb* (880 kg)*	970 lb (440 kg)	
+3 ft (1.0 m)					3,263 lb* (1 480 kg)*	1,852 lb (840 kg)	2,381 lb* (1 080 kg)*	1,235 lb (560 kg)	16 ft 1 in (4.91 m)	2,072 lb* (940 kg)*	904 lb (410 kg)	
Groundline			8,047 lb* (3 650 kg)*	3,153 lb (1 430 kg)	4,012 lb* (1 820 kg)*	1,742 lb (790 kg)	2,712 lb* (1 230 kg)*	1,191 lb (540 kg)	15 ft 8 in (4.77 m)	2,205 lb* (1 000 kg)*	926 lb (420 kg)	
-3 ft (-1.0 m)		14,749 lb (6 690 kg)	7,562 lb* (3 430 kg)*	3,153 lb (1 430 kg)	4,123 lb* (1 870 kg)*	1,720 lb (780 kg)	2,734 lb* (1 240 kg)*	1,168 lb (530 kg)	14 ft 3 in (4.34 m)	2,403 lb* (1 090 kg)*	1,058 lb (480 kg)	
-7 ft (-2.0 m)			5,975 lb* (2 710 kg)*	3,263 lb (1 480 kg)	3,395 lb* (1 540 kg)*	1,764 lb (800 kg)			11 ft 5 in (3.48 m)	2,601 lb* (1 180 kg)*	1,455 lb (660 kg)	

NOTE: Lifting capacity are based on ISO 10567.

Lifting capacity does not exceed 75% of tipping load with the machine on firm, level ground or 87% of full hydraulic capacity. Back of the arm linkage.

*Indicates load limited by hydraulic capacity.

For lift capacities with additional counterweights please see operators manual.

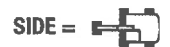
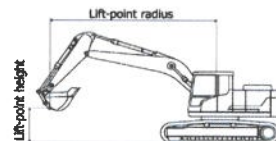

STANDARD EQUIPMENT

ENGINE

KUBOTA D1803
Glow Plugs for cold weather starting
Dry air filter with clogged filter warning on control panel
Variable Speed Hydraulic cooling fan with reverse function

ELECTRICAL

12-volt electrical system
Heavy-duty battery
Battery disconnect switch
Auxiliary Power Socket (left console, right-hand upright)
USB type A power socket
Key Start Switch
Auxiliary Power socket on roof for beacon
Auto-idle feature with on/off switch
Horn
Pre-wired – Telematics ready

OPTIONAL EQUIPMENT

OPERATOR ENVIRONMENT

Fabric Pneumatic Seat with automatic weight control (cab only)
Travel Alarm

TRACK OPTIONS

Tracks:
Steel Tracks

HYDRAULICS

Standard 1st auxiliary hydraulics. 1 or 2 way operation. Set in control panel.
2nd auxiliary hydraulics – 2-way
Large hydraulic oil cooler
Control pattern selector valve
Cylinder guard on boom and dozer blade cylinder

TRACK DRIVE

Rubber belt tracks
2-speed travel (turtle & rabbit) with auto-shift
Fully hydrostatic drive system
Sealed and lubricated track rollers
Track Tensioner Hydraulic adjustment with grease

LIGHTING

LED light under boom
LED strip lights on right hand side engine cover
Courtesy Light with 3 settings:
Always on
Always off
Automatic when door is open (cab only)

VISIBILITY

Rear view camera
LED lights on top of cab/canopy, front and rear
Beacon

HYDRAULICS

3rd auxiliary hydraulics – 2-way
Direct drain to tank
Load holding valves on boom and arm
Mulcher hydraulics package
Bio hydraulic oil

UPPER STRUCTURE

Zero Tail Swing (with standard counterweight)
Standard arm: 4 ft 7 in (1.40 m)
Linkage with lifting hook
Thumb bracket
Backfill blade with float

OPERATOR ENVIRONMENT

See page 1

OTHER

Swing boom – 71° left/56° right

WARRANTY

Base warranty coverage: 2-Year/3,000-Hour
Full Machine Limited Warranty

OTHER

6-way backfill blade
Additional counterweight adds: 617 lb (280 kg)
Additional counterweight - heavy:
926 lb (420 kg)
Optional long arm: 5 ft 5 in (1.65 m)

ATTACHMENTS

Mechanical quick coupler
Hydraulic quick coupler
Digging buckets
Thumb

CaseCE.com

©2022 CNH Industrial America LLC. All rights reserved. CASE is a trademark registered in the United States and many other countries, owned by or licensed to CNH Industrial N.V., its subsidiaries or affiliates. CNH Industrial Capital is a trademark in the United States and many other countries, owned by or licensed to CNH Industrial N.V., its subsidiaries or affiliates. Printed in U.S.A. Contains 10% post-consumer fiber.

IMPORTANT: CASE Construction Equipment Inc. reserves the right to change these specifications without notice and without incurring any obligation relating to such change. Availability of some models and equipment builds vary according to the country in which the equipment is used. The illustrations and text may include optional equipment and accessories and may not include all standard equipment. Your CASE dealer/distributor will be able to give you details of the products and their specifications available in your area.



CASE Construction Equipment is biodiesel-friendly. NOTE: All engines meet current EPA emissions regulations. All specifications are stated in accordance with SAE Standards or Recommended Practices, where applicable.



Always read the Operator's Manual before operating any equipment. Inspect equipment before using it, and be sure it is operating properly. Follow the product safety signs and use any safety features provided.

Form No. CCE202211CX42D

CX42D