

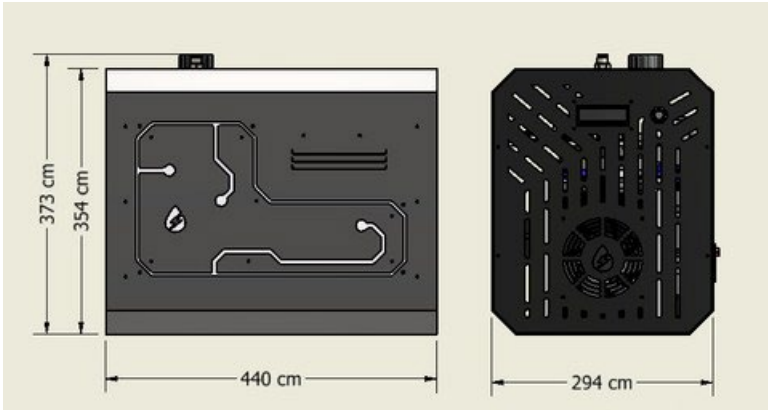

## DIMENSIONS: ELECTROLYZER W



## TECHNICAL SPECIFICATIONS

Power	480W Max
Input voltage	12 VDC - 110VAC - 220VAC
Nominal pressure	(1 - 12) psi
Thermal power	60.000 BTU/lb
Fuel type	H2O (Water)
Fuel consumption	0.038 gal/h Max
Type of gas produced.	HHO
Gas flow rate	0.2 - 1 gpm
Fuel (water) filling	Manual
Ignition	Manual
Pressure safety switch	Yes (17 psi)
Leak sensor	HHO sensor
Safety system	Flashback arrestor system
Dimensions	(44 cm) <b>17 in</b> x (29 cm) <b>11.6 in</b> x (37 cm) <b>14.7 in</b>
Weight	13 pounds
Standard Service life	8 years

## CUSTOM HHO BURNER



## FLASHBACK ARRESTOR SYSTEM

