



# ULTRA SEAM - PERIMETER EDGING SYSTEMS

## SC SERIES COPING

Manufactured by  
 Ultra Seam  
 Metal Roofing &  
 Siding Systems  
 www.ultraseam.com

YOUR LOCAL PLANT:

**METAL DESIGN &  
 MANUFACTURING**

313-893-9810

Fax 313-893-9815

roger@metaldesignmfg.com

www.metaldesignmfg.com

The IBC building code requires that all low slope roofing systems ( built up asphalt, single ply, modified, etc.) use perimeter metal details that have tested according to the ANSI / SPRI ES-1 testing procedure. This applies to copings, gravel stops, and metal edgings. Most states have adopted the provisions of the IBC building code. ULTRA SEAM has developed a line of coping, gravel stops, and edging that have been tested in both aluminum and steel options. We have standard and snap lok versions of each type of trim.

### ES-1 TESTED!

THE ULTRA SEAM STANDARD STYLE COPING ( SC SERIES COPING ) IS A TRADITIONAL STYLE COPING THAT IS FAST AND SIMPLE TO INSTALL. FRONT CLEAT INTERLOCK AND BACKSIDE THRU FASTENING PROVIDES SECURE PERIMETER ATTACHMENT OF THE ROOF MEMBRANE

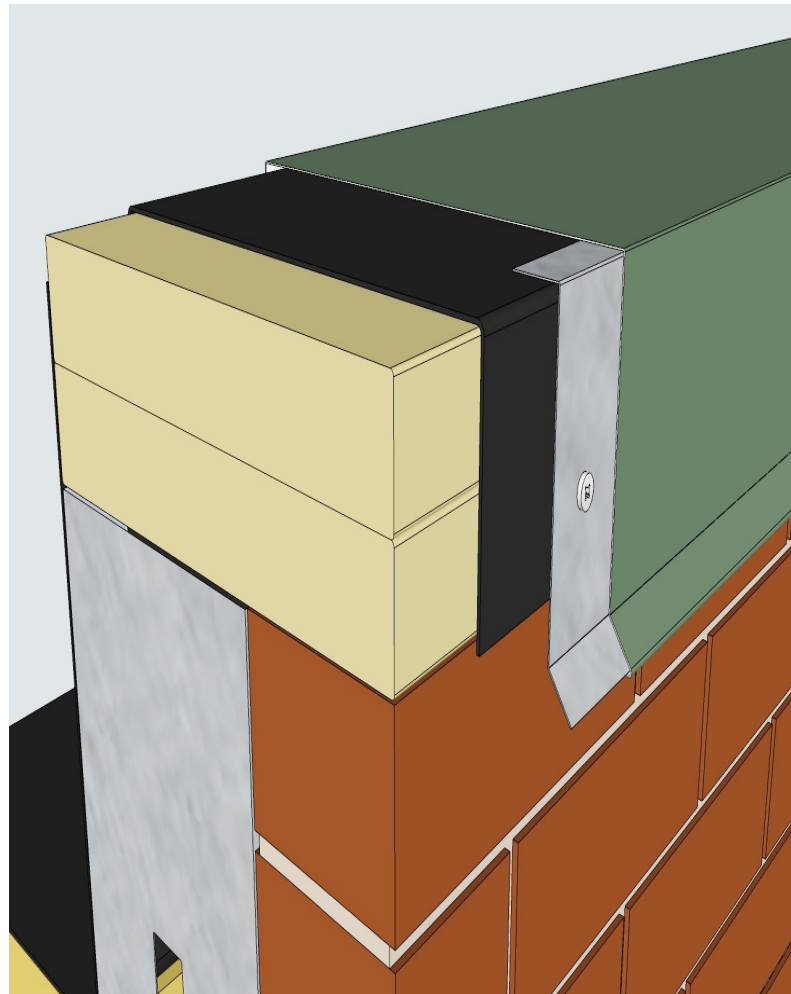
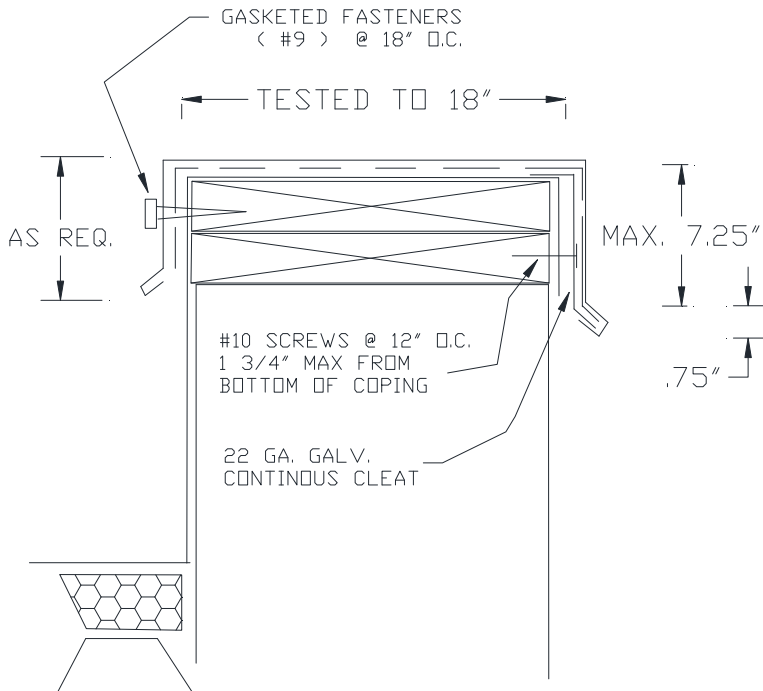

SC SERIES ( STANDARD STYLE ) COPINGS ARE AVAILABLE IN VARIOUS METALS. THEY ARE ES-1 TESTED IN 24 GA. STEEL AND .040 ALUMINUM. MAXIMUM TESTED FACE SIZE IS 8". CALL ULTRA SEAM FOR DETAILS.