



ULTRA SEAM - PERIMETER EDGING SYSTEMS

UE SERIES EDGINGS

Manufactured by
 Ultra Seam
 Metal Roofing &
 Siding Systems
 www.ultraseam.com

YOUR LOCAL PLANT:

**METAL DESIGN &
 MANUFACTURING**

313-893-9810
 Fax 313-893-9815
 roger@metaldesignmfg.com
 www.metaldesignmfg.com

The IBC building code requires that all low slope roofing systems (built up asphalt, single ply, modified, etc.) use perimeter metal details that have tested according to the ANSI / SPRI ES-1 testing procedure. This applies to copings, gravel stops, and metal edgings. Most states have adopted the provisions of the IBC building code. ULTRA SEAM has developed a line of coping, gravel stops, and edging that have been tested in both aluminum and steel options. We have standard and snap lok versions of each type of trim.

ES-1 TESTED!

ULTRA EDGE (UE SERIES EDGING) IS A SNAP LOCK STYLE EDGING THAT HAS A FAST AND SIMPLE INSTALLATION PROCEDURE THAT REDUCES YOUR LABOR COSTS AND INCREASES PROFITS. THIS SYTEM ALLOWS YOU TO COMPLETE THE INSTALLATION OF YOUR ROOF MEMBRANE WITHOUT HAVING YOUR SHEET METAL INSTALLERS ON THE PROJECT. WHEN YOU DO INSTALL THE ULTRA EDGE YOU WILL NOT NEED TO HAVE THE ROOFERS RETURN TO THE PROJECT TO STRIP IN THE EDGING.

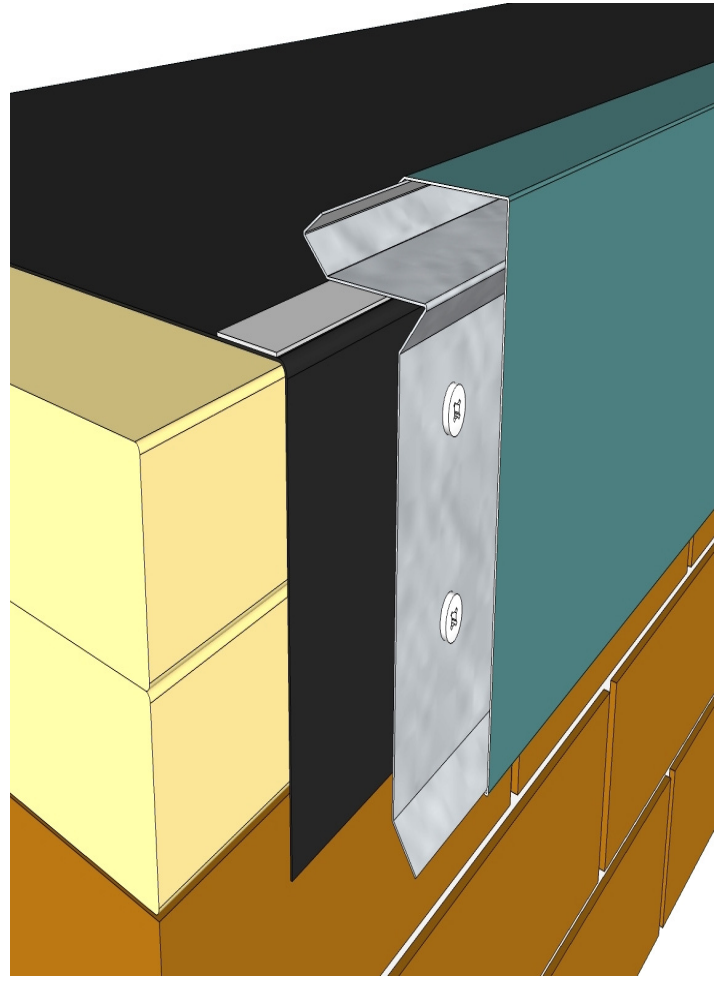
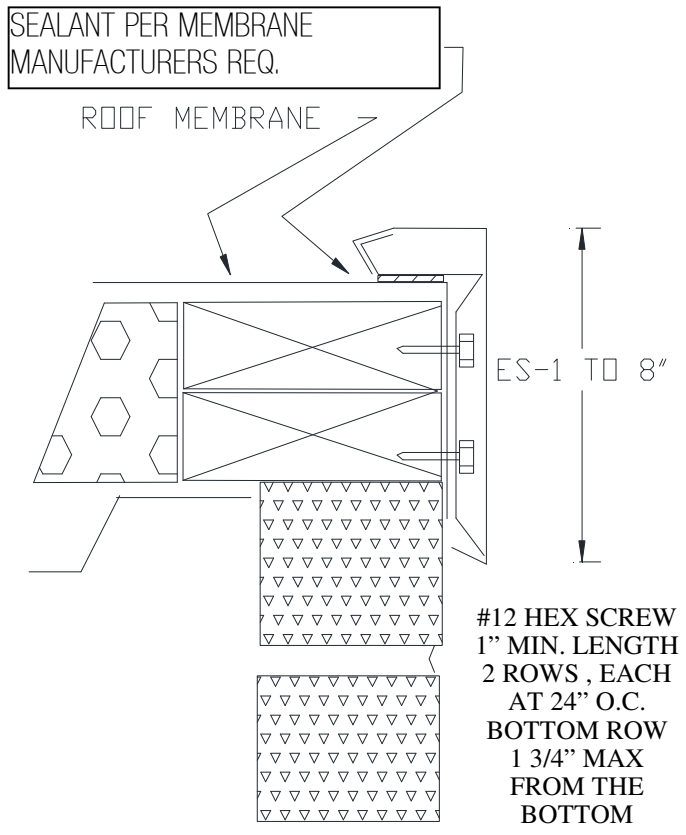

UE SERIES (ULTRA EDGE) EDGINGS ARE AVAILABLE IN VARIOUS METALS. THEY ARE ES-1 TESTED IN 24 GA. STEEL AND .040 ALUMINUM. MAXIMUM TESTED FACE SIZE IS 8" . CALL ULTRA SEAM FOR DETAILS.