

PRODUCT FEATURES

- ▶ Super quiet with noise level only 36.5dB(A)@1m on high speed
- ▶ DC motor for superior performance and energy efficiency
- ▶ Constant air volume output promises performance and widens spec-in solutions
- ▶ 24 hour ventilation settings to avoid mould and damp issues
- ▶ Built in 15 minute run-on timer, no external timer is required
- ▶ Built in backdraft damper meets BCA requirements
- ▶ Slim profile and compact design making it suitable for tight ceilings
- ▶ Light weight making installation easier
- ▶ Intelligent motion sensor detects human activity for auto on/off (FV-24JR3 only)
- ▶ Peace of mind with 3 year parts and labour warranty

FV-24JR3 (WITH MOTION SENSOR)



FV-24JA3



DIMENSIONS

FV-24JR3 & FV-24JA3

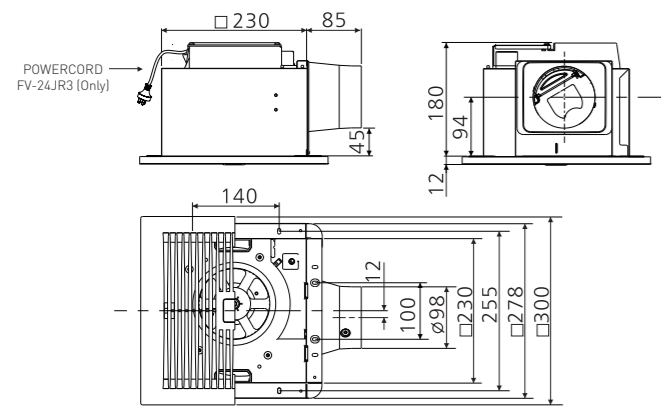

PERFORMANCE CURVE

FV-24JR3 & FV-24JA3

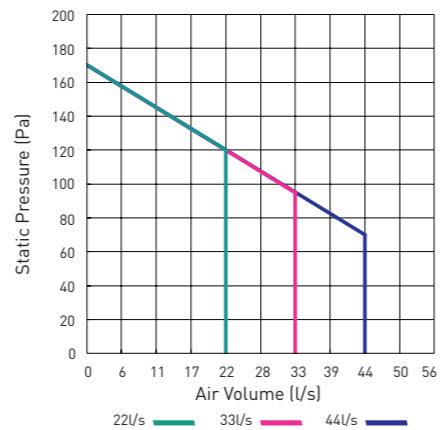

| MODEL | ELECTRICAL SUPPLY | AIR VOLUME [l/s] | POWER CONSUMPTION [W] | NOISE @ 1m [dB(A)] | NET WEIGHT [kg] | INSTALLATION CUT-OUT [mm] | DUCT DIAMETER [mm] |
|---------------------|------------------------------|------------------|-----------------------|----------------------|-----------------|---------------------------|--------------------|
| FV-24JR3 & FV-24JA3 | 240V SINGLE PHASE 50Hz | 44 33 22 | 9.3 5.5 3.6 | 36.5 30.5 24.5 | 3.0 2.9 | 230x230 | 100 |

Please read the Installation Instructions carefully before installing the unit, and the Operating Instructions before using it. Specifications are subject to change without prior notice. The contents of this catalogue are accurate as of November 2020. Due to printing considerations, the actual colours may vary slightly from those shown. All graphics are provided merely for the purpose of illustrating a point.
20VEN1101

Panasonic Australia Pty. Limited

1 Innovation Road,
Macquarie Park,
NSW 2113
ACN 001 592 187
ABN 83 001 592 187
Website : aircon.panasonic.com.au



Panasonic
Air Conditioning

Panasonic

VENTILATION FANS
CEILING MOUNTED
DC MOTOR WITH MOTION SENSOR



QUALITY AIR FOR LIFE



HIGHER LIVING STANDARDS

Panasonic introduces a brand new range of Direct Current (DC) Motor Ceiling Mounted Ventilation Fans. With whisper quiet operation & energy efficient performance, these fans provide a quiet and comfortable environment within your home.

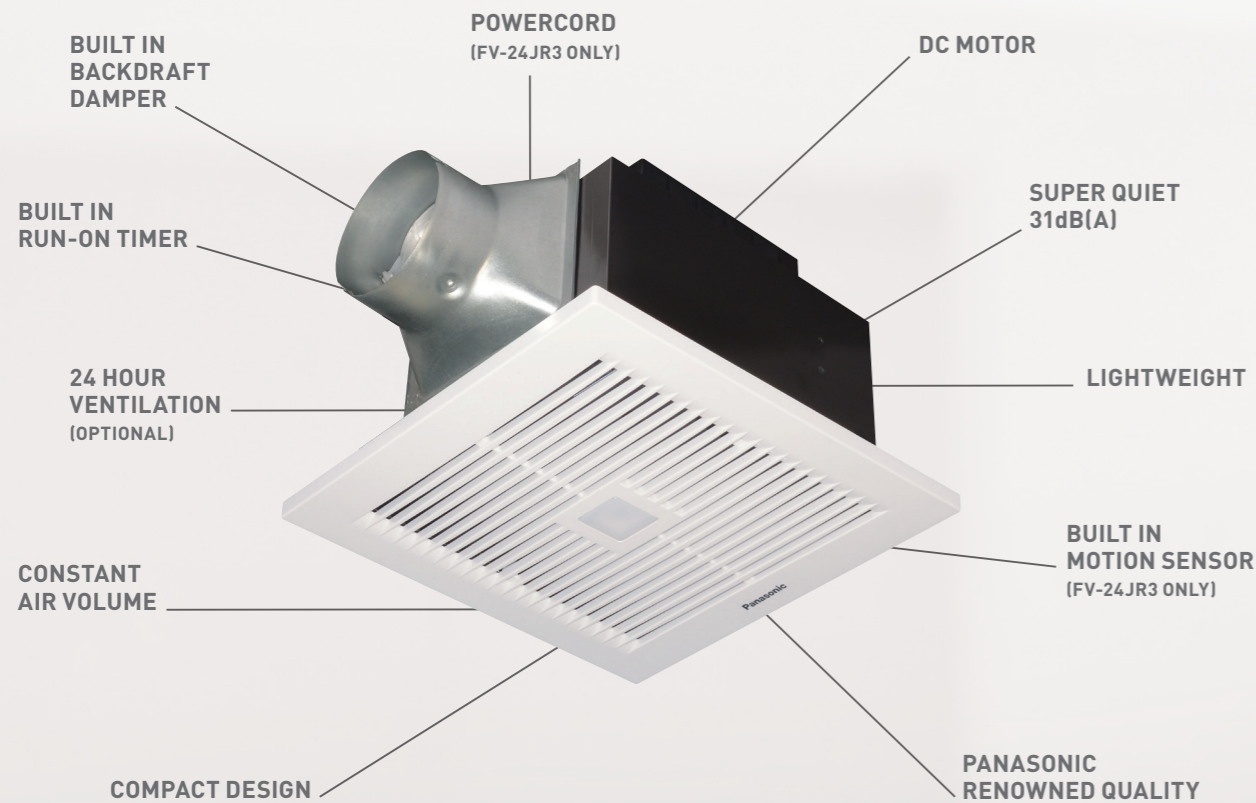

QUIET OPERATION - LOW NOISE DESIGN

These fans adopt a distinctive Resonance-Noise-Absorption Structure design. Minimising the transmission of noise from blower to exterior. Reducing the operation noise to incredibly low levels, creating a tranquil and silent environment. The Double Chamber Structure, allows noise to be effectively absorbed and reduced between the double orifice and casing.



ENERGY SAVING - DC MOTOR

Our fans feature a DC Motor to reduce power consumption and save energy. The DC Motor operating temperature is comparatively lower than AC motors, providing a longer lifetime than their AC counterparts.



Modern homes are built with aluminum casing windows and rubber lined doors throughout in order to retain maximum energy efficiency. Most homes and commercial buildings feature sealed windows and doorways in order to limit heating or cooling loss. This generally results in poor Indoor Air Quality (IAQ).

CONSTANT AIR VOLUME

Our fans are equipped with intelligent technology, allowing them to automatically maintain constant air volume within the fan operating limits, to suit varying external static pressures (see performance curve).



24 HOUR VENTILATION

Instead of switching off after the run-on timer is finished, the fan can be set to then run at a low airflow setting continuously (avoiding mould and damp issues). This feature is optional and can be configured to suit each homes individual requirements.



BUILT-IN RUN-ON TIMER

Equipped with a run-on timer, the fan can be configured to either switch off or switch to 24 hour ventilation mode after 15 minutes.



INTELLIGENT MOTION SENSOR*

Equipped with an intelligent Motion Sensor, our ventilating fans can detect human activity and switch on automatically when you enter the room and then switch off again after you leave.

* FV-24JR3 only



COUNT ON PANASONIC

Our fans are manufactured to the highest quality standards to ensure years of reliable comfort. We even back our reliability by offering a full 3 year parts and labour warranty.

