

SUNSET LAKE ASSOCIATION

JANUARY 7, 1992

The regular Sunset Lake Board of Directors meeting was held, Tuesday, January 7, 1992 at the lake office, 119 W. Madison, Girard. Due to the absence of Pres. Frank Gibbons, Vice-President Ray Reardon called the meeting to order at 7:00 p.m. with the following Directors present: Ray Reardon, Terri Charles, Sharon Lindsay, Ward Walker, David Miller, Henry Sutton and Ray Stansberry. Also present were William Hohimer, patrolman, and Glenda Sutton, Secr.

Patrolman's Report: A motion was made by R. Stansberry and seconded by T. Charles to approve the December Patrolman's report as presented. Motion carried.

Minutes: A motion was made by R. Stansberry and seconded by S. Lindsay to approve the December 3, 1991 minutes as presented. Motion carried.

Bills: A motion was made by H. Sutton and seconded by W. Walker to approve for payment bills totaling \$3,773.25. Motion carried.

Aquatic Control, Recreation & Water Safety: W. Walker reported Christmas trees were being collected to put in lake at a future date, everything else slow due to weather.

Farm Management: R. Stansberry reported wheat crop is growing as well as can be expected for this time of year.

Roads & Grounds: H. Sutton reported the snow plow is ready for bad weather plus a small amount of cinders available for roads.

Sanitation, Shoreline & Boat Docks: D. Miller reported on checking Lot #239, David Werry, for transfer and found everything acceptable.

Old Business: S. Lindsay reported the Rules & Regulations committee has meet once and is planning another meeting before presenting any suggested changes.

R. Reardon stated he has not been able to contact the local fire department concerning constructing more fill stands at Sunset Lake area. He will check with department on Monday which is their meeting night.

H. Sutton reported he informed Bruce Weller #130 that the Board will not approve the construction of a tree house on lake property.

New Business: T. Charles handed out papers to everyone explaining her resignation as Treasurer.

H. Sutton asked for T. Charles to reconsider her resignation for another month and possibly write down her ideas for a Treasurer's position and responsibilities. She agreed and withdrew the papers.

R. Stansberry asked W. Hohimer if there was anything in need of repair.

W. Hohimer stated the pick-up truck was in need of realignment. Sutton said to go ahead with truck repair.

W. Hohimer reported the tractor tires were examined and nothing was found to be seriously wrong.

D. Miller suggested a number system be organized on the Snell Lots when they are sold to coincide with our present lot numbering system.

JANUARY 7, 1992

Transfers: A motion was made by S. Lindsay and seconded by T. Charles to accept for transfer Lot 1, Block 33, Meter #239 David P. Werry to Brett C. Berryman. Motion carried.

A motion was made by R. Stansberry and seconded by W. Walker to accept for transfer Lot 1, Block 23, Meter #162 Howard Finney to Phillip G. Finney and Karen G. Finney subject to Sanitation and Shoreline committee report. Motion carried.

A motion by T. Charles and R. Stansberry was made to adjourn meeting. Motion carried.

Adjourned 7:45 p.m.

*Glenda M. Sutton*

Secretary

PATROLMAN'S REPORT  
JANUARY 1992

- Jan. 2 Called REA, two street lights were out on North side, second time in two weeks. Picked up Christmas trees in town to put in lake.
- 3 Picked up trees and picked up trash along road.
- 6 Spread rock along roads and mail boxes, burnt brush.
- 7 Got load of cement blocks to tie trees down and picked up trees. Lake meeting that evening.
- 8 Went to F.S. to see about lake chemical bill. They said they wouldn't charge us till we used it.
- 9 Burnt brush, light snow.
- 10 Cut and burnt dead trees on North side.
- 13 Cut brush and trimmed trees.
- 14 High winds and blowing snow, kept roads opened and helped people out of ditch.
- 15 Cold weather, spread fly ash.
- 16 Warmer weather, plowed ice off of roads.
- 17 Plowed more ice and spread fly ash.
- 20-24 Cut and burnt brush, then cleaned up.
- 27-31 Cut dead trees and cleaned up.

Bill Hohimer

SUNSET LAKE ASSOCIATION

FEBRUARY 4, 1992

Bills to be approved for payment :

		\$	6.50
Nilwood Water System			134.51
Rural Electric Conv.			
GTE-North	- 627-3232	- \$	41.41
	- 627-3339	-	33.31
			303.56
Macoupin Service Co.	- fuel		7.93
Girard Auto Supply	- maintenance supplies		15.00
Girard Home Oil	- kerosene		7.78
Girard Hardware	- bolts, chains sharpened		
ADGPTV Water Commission	- utilities	- \$	75.00
	- address changes	-	9.46
			84.46
State Bank of Girard	- Fed. W/H & FICA Taxes		450.78
State Bank of Girard	- petty cash		13.20
Glenda Sutton	- net salary		351.47
William Hohimer	- net salary		<u>1,072.77</u>
	Total	\$	2,522.68

SUNSET LAKE ASSOCIATION

AGENDA

January 7, 1992

CALL TO ORDER

ROLL CALL

VISITORS' REMARKS

PATROLMAN'S REPORT

APPROVAL OF MINUTES OF December 3, 1991

APPROVAL OF BILLS

COMMITTEE REPORTS:

AQUATIC CONTROL & RECREATION & WATER SAFETY

- WARD WALKER

BUILDING & CONSTRUCTION

- TERRI CHARLES

FARM MANAGEMENT

- RAY STANSBERRY

FINANCE

- TERRI CHARLES

LEGAL & LITIGATION

- FRANK GIBBONS & AL TRETTE

PUBLIC RELATIONS

- SHARON LINDSAY

ROADS & GROUNDS

- HENRY SUTTON

SANITATION, SHORELINE & BOAT DOCKS

- DAVID MILLER

WATER QUALITY, SOIL CONSERVATION & RESTORATION - RAY REARDON

OLD BUSINESS

NEW BUSINESS

TRANSFERS: Lot 1 Block 33 ,Meter #239 David P. Werry to Brett C.  
Berryman.

TO: Board Directors

FROM: Secretary

Please plan to attend the regular Directors meeting Tuesday,  
January 7, 1992 at 7:00 p.m. at lake office. A social hour will  
be held immediately following the meeting at the Grub & Pub Resturant  
for Directors and spouses.

SUNSET LAKE ASSOCIATION  
FEBRUARY 4, 1992

The regular Sunset Lake Board of Directors meeting was held Tuesday, February 4, 1992 at the lake office, 119 W. Madison, Girard. Pres. Frank Gibbons called the meeting to order at 7:30 p.m. with the following Directors present: Frank Gibbons, Henry Sutton, Terri Charles, Ray Reardon, Ward Walker, Al Tretter, David Miller, Sharon Lindsay and Ray Stansberry. Also present were visitors Robert and Carol Foster, employees, Glenda Sutton and William Hohimer.

Visitor's Report: Robert and Carol Foster #194 were present to reply to a letter they had previously mailed to Board complaining about sedimentation in their cove, they have lost six feet of cove since they moved there in 1986. They feel the problem is not all theirs to deal with because of a ditch located on Sunset Lake property in that area and asked Board for assistance with this situation.

Board explained several members have taken it upon themselves to dig out their own cove, because the general membership has so far turned down any program toward dredging lake. Board agreed that if a membership petition was presented to Board asking for a special meeting or to put on annual meeting agenda to pass a special assessment for soil conservation around lake, the Board would act upon this request.

Patrolman's Report: A motion was made by R. Stansberry and seconded by W. Walker to accept the January Patrolman's Report as presented. Motion carried.

W. Hohimer reported last Friday lake street signs were pulled up, some thrown on ice in lake, others switched around to other street signs, plus some street lights on North side being shot out several times. Rural Electric has replaced lights, but will refuse to replace if situation continues.

Minutes: A motion was made by H. Sutton and seconded by R. Stansberry to accept January 7, 1992 minutes as presented. Motion carried.

Bills: A motion was made by R. Stansberry and seconded by A. Tretter to approve for payment bills totaling \$2,522.68. Motion carried.

Legal & Litigation: F. Gibbons read a letter received from Ed Snell and Delores Harms who are looking forward to becoming Sunset Lake members and are ready to sign proper papers. Gibbons also explained a quit claim deed concerning the easement near Meter #1 Stuart Dobbs mailed that needs to be approved by Board, then signed and returned to Dobbs who will then take all agreements to Judge for final approval.

A motion was made by R. Stansberry and seconded by A. Tretter to accept signing the quit claim deed on the easement and returning to attorney for final approval on all agreements. Motion carried unanimously.

Sanitation, Shoreline & Boat Docks: D. Miller reported a new sanitation system was installed at David Werry #217, all permits are approved, therefore he requested the \$3600 escrow being held by lake office be released to Werry and Terry Clark, contractor. Miller also reported, Lot #12 Wacker has an agreement with buyer to install a new system; Lot #70 A&B, Charles Dodge's boat dock repairs have been accomplished and Miller suggested a letter be sent to Champion

FEBRUARY 4, 1992

Federal Bank requesting them to release to the Dodges the \$200 escrow they are holding.

Water Quality, Soil Conservation & Restoration: R. Reardon reported on water sample tests taken, results were good, he will probably cut down his testing to three times a year which is enough to establish a accurate record of water clarity throughout the year.

Old Business: T. Charles reported on committee's draft of list of fines to be approved for lake's Rules & Regulations. Each Director was given a list for their suggestions or changes before approval at next meeting.

T. Charles passed out her resignation as Treasurer for the Board's approval.

After some discussion concerning the contents of the resignation, a motion was made by H. Sutton to not accept T. Charles' resignation in the form presented.

Motion was dropped from lack of a second, and from S. Lindsay's suggestion that T. Charles withdraw her resignation and work with Board and Secretary to work on Treasurer's work description. T. Charles agreed.

R. Reardon explained talking to Girard Fire Dept. about installing more fill hydrants around lake area. Dept. stated it was not advisable or practical on any 4" water mains, but some might be installed on a 6" main near lake dam or there could be installed some dry hydrants which would be available to fill tanks from lake. Reardon stated he would contact the Nilwood Water Dept. on their ideas and possible cost, then present to members at annual meeting for their approval.

New Business: F. Gibbons asked Board's opinion on Illinois Youth Work Program.

H. Sutton stated he and W. Hohimer decided there was need for only one boy to work this summer due to no major projects planned this year.

H. Sutton stated the IL. Lake Management Asso. annual meeting will be held in April in Rockford in case someone is interested in attending.

A. Tretter reported on possibly purchasing a uniform for our patrolman, like a shirt with his name and lake logo on it plus a hat, the cost approximately \$200. He will check on exact cost and styles and report at next meeting.

D. Miller stated a small area of shoreline next to public boat ramp needs rip rapped. H. Sutton suggested using broken concrete they get occasionally.

F. Gibbons reported on a request from O. Hines lot #68 to build a new garage attached to house and keep old garage but also attach it to house. Board agreed on design subject to proper building permits being approved.

Transfer: A motion was made by T. Charles and seconded by D. Miller to approve for transfer Lot 6 Block 27 Meter #208 Louis E. Long and Sue A. Long to John Mattsson subject to \$100 escrow held to cover expense for rip rapping 20' of shoreline. Motion carried.

A motion was made by S. Lindsay and seconded by R. Stansberry to adjourn meeting. Motion carried.

Adjourned 10:00 p.m.

*Glenda M. Sutton*  
Secretary

SUNSET LAKE ASSOCIATION  
CASH POSITION  
FEBRUARY 29, 1992

		\$ 100.00
Cash on Hand (petty cash)		
State Bank of Girard	\$ 200.70	
Checking	24,021.95	
Money Market Fund - General	<u>66.42</u>	\$ 24,289.07
- Interest		<u>88.00</u>
Prudential-Bache		\$ 24,477.07
Total General Revenue		
State Bank of Girard	\$ 14,594.21	
Money Market Fund - Special (dam)	<u>53.18</u>	\$ 14,647.39
- Interest		<u>\$ 39,124.46</u>
Total Revenue		
		<u>\$ 200.00</u>
State Bank of Girard (escrow)		

Monthly Receipts:

		\$ 12,645.24
Assessments	35.00	
- General	11.00	
- Island	-0-	
Boat Permits	-0-	
Building Permits	200.00	
Fines & Penalties	56.00	
Transfer Fees	24.00	
Earned by Maintenance Man	8.00	
Misc. Income	<u>1,226.24</u>	\$ 14,205.48
- Chlorine Tablets		
- Hats		
- Cablevision		
Total		



SUNSET LAKE ASSOCIATION

AGENDA

February 4, 1992

CALL TO ORDER

ROLL CALL

VISITORS' REMARKS

PATROLMAN'S REPORT

APPROVAL OF MINUTES OF January 7, 1992

APPROVAL OF BILLS

COMMITTEE REPORTS:

AQUATIC CONTROL & RECREATION & WATER SAFETY

BUILDING & CONSTRUCTION

FARM MANAGEMENT

FINANCE

LEGAL & LITIGATION

PUBLIC RELATIONS

ROADS & GROUNDS

SANITATION, SHORELINE & BOAT DOCKS

WATER QUALITY, SOIL CONSERVATION & RESTORATION

- WARD WALKER
- TERRI CHARLES
- RAY STANSBERRY
- TERRI CHARLES
- FRANK GIBBONS & AL TRETT
- SHARON LINDSAY
- HENRY SUTTON
- DAVID MILLER
- RAY REARDON

OLD BUSINESS

NEW BUSINESS - IL. Youth Work Program

TRANSFERS: Lot 6 Block 27 Meter #208 Louis E. Long & Sue A. Long  
to John Mattsson

TO: Board Director

FROM: Secretary

Please plan to attend the regular Directors meeting held on  
Tuesday, February 4, 1992 at 119 W. Madison (lake office) at  
7:30 p.m.

SUNSET LAKE ASSOCIATION  
CASH POSITION  
JANUARY 31, 1992

		\$ 100.00
Cash on Hand (Petty Cash)		
State Bank of Girard	\$ 2.09	
Checking	12,516.27	
Money Market Fund - General	29.95	
- Interest	(5.00)	
- Service Charge	<u>          </u>	\$ 12,543.31
Prudential-Bache		<u>\$ 88.00</u>
Total General Revenue		\$ 12,731.31
State Bank of Girard	\$ 14,528.04	
Money Market Fund - Special (Dam)	66.17	
- Interest	<u>          </u>	\$ 14,594.21
Total Revenue		<u>\$ 27,325.52</u>
State Bank of Girard - Escrow		<u><u>\$ 3,800.00</u></u>

Monthly Receipts:

		\$ 12,736.59
Assessments	- General	-0-
Boat Permits		-0-
Building Permits		-0-
Fines & Penalties		200.00
Transfer Fees		-0-
Earned by Maintenance Man		16.00
Misc. Income	- Chlorine Tablets	<u>          </u>
Total		<u><u>\$ 12,952.59</u></u>

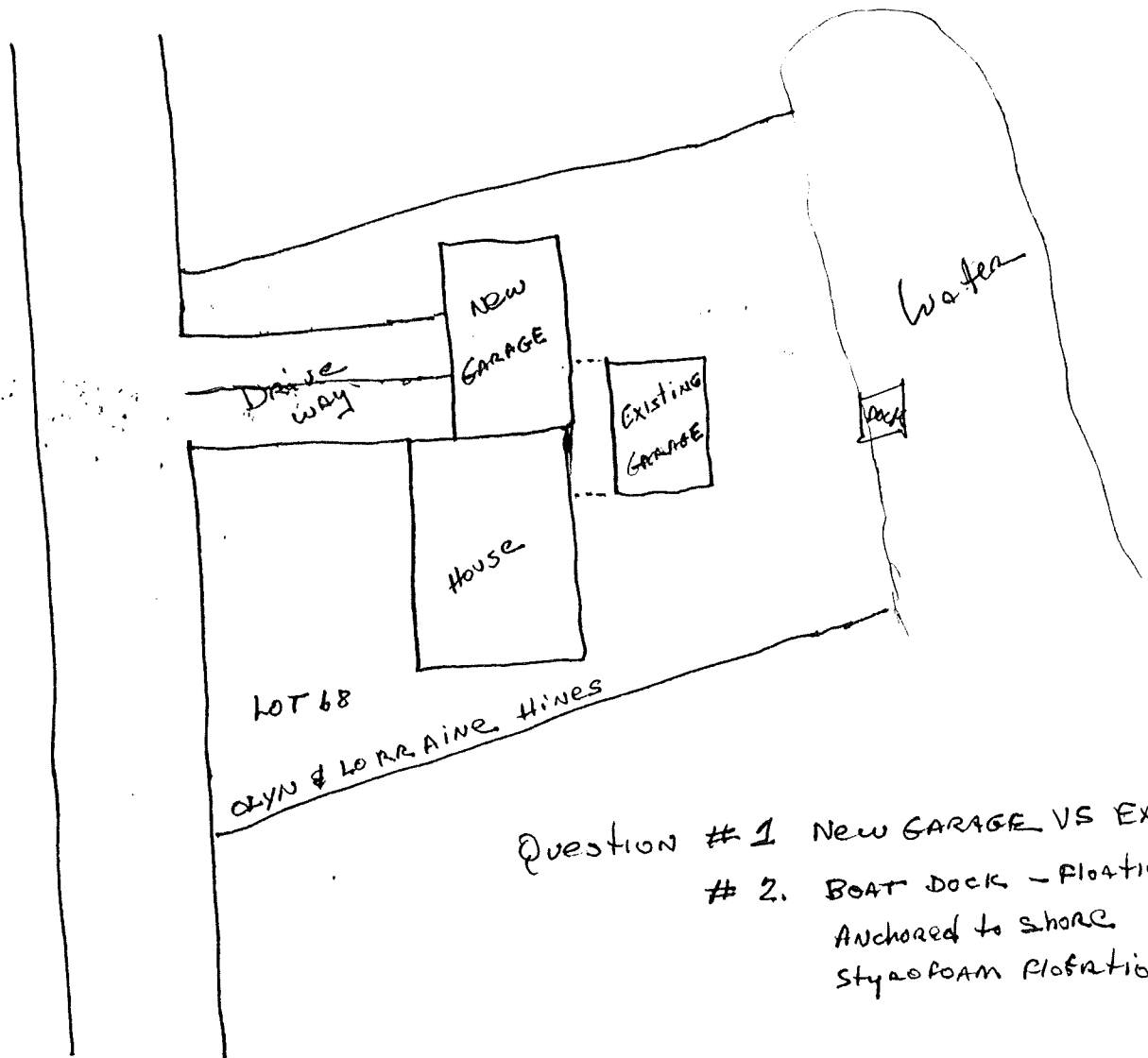

Question # 1 New GARAGE VS EX  
# 2. BOAT DOCK - FLOATING  
ANCHORED TO SHORE w  
STYROFOAM FLOTATION

SUNSET LAKE ASSOCIATION

MARCH 3, 1992

The regular Sunset Lake Board of Directors meeting was held Tuesday, March 3, 1992 at the lake office, 119 W. Madison, Girard. Pres. Frank Gibbons called the meeting to order at 7:30 p.m. with the following Directors present: Terri Charles, Sharon Lindsay, Ray Stansberry, Henry Sutton, Ray Reardon, Al Tretter, Ward Walker, Dave Miller and Frank Gibbons. Employees William Hohimer and Glenda Sutton were also present.

Patrolman's Report: A motion made by R. Stansberry and seconded by R. Reardon approved the February Patrolman's Report as presented. Motion carried.

Minutes: A motion made by S. Lindsay and seconded by R. Stansberry to approve the February 4, 1992 minutes as presented. Motion carried.

Bills: A motion by H. Sutton and seconded by D. Miller accepted the bills for payment which totaled \$2,829.26. Motion carried.

Aquatic Control, Recreation & Water Safety: W. Walker reported only a few boats on the water; he, William Hohimer & Paul Erley attended a meeting in Girard that Macoupin Service and Otter Lake Water Commission had arranged to discuss the hazards of the chemical atrazine draining into Otter Lake which is the surrounding community's water supply. Walker stated that according to the program presented, the Association is doing what is necessary to assure lake's quality.

H. Sutton also attended the same type of meeting in Palmyra and stated although there is only a trace of atrazine in Otter Lake our lake maintenance program should be continued because all lakes will eventually be tested, starting with water supply lakes.

Building & Construction: T. Charles reported on two building permits: Brett Berryman #239, fenced dog run; Glenn Ford #156, boat dock.

Farm Management: R. Stansberry presented a graph showing the income and expenses during a 10 year period, then an average of income and expenses with an average profit of \$2,076.33.

Finance: T. Charles stated she would be gone on the May meeting, but would like to start preparing 1993 Budget with a committee. The following people will be on budget committee: T. Charles, F. Gibbons, H. Sutton and S. Lindsay.

Legal & Litigation: F. Gibbons reported the Snell case is almost finalized; the Wyatt case is moving forward, depositions from Clem Charles, George Lane and Glenda Sutton are to be taken March 10th, they are meeting with our attorney, Stuart Dobbs, tomorrow, March 4th to discuss the case, if any Board Directors wish to attend this meeting to ask questions, it starts at 7:00 p.m. at the lake office.

Roads & Grounds: H. Sutton reported on inspecting a culvert problem located near Lot #7, he will continue to monitor. He also has no plans to oil & rock the roads this year.

Sanitation, Shoreline & Boat Docks: D. Miller reported on no escrow being held from Louis Long #208 on shoreline, Long rip rapped his shoreline and also a small patch of our shoreline near public boat ramp.

Miller reported on a complaint from Walt Clark #240 concerning his neighbor's lot #239 lack of a sanitation system; he will contact the new owner about the situation and report findings later.

Old Business: F. Gibbons asked if there were any changes to the submitted list of fines that are to be added to the Rules & Regulations.

There were several revisions: Section 5 (Water Pollution) will be changed to "Section 5 & 6 (Pollution)"; Section 12 will include 9 & 10; a paragraph will state: "12 months from previous offense unless otherwise stipulated"; another paragraph will discuss the collection of fines, taking wording out of Section 37 on page 12 starting with "After receiving written request ..." adding after deficiency, "or being issued a citation". A letter could also be sent with fines explaining the necessity of defining fines individually.

A motion was made by R. Stansberry and seconded by R. Reardon to accept the revised list of fines which include the additions and changes previously mentioned. Motion carried.

A newsletter will be included with the mailing going to members shortly and H. Sutton asked to include a notice that an Inspecting Committee will be doing a general clean-up inspection on lots now through May.

R. Reardon stated he will attend the Monday night Nilwood Water Department meeting to discuss having additional fill hydrants installed at lake area and will report findings at next meeting.

Sutton reported on a new smaller type of dredging equipment, information shows process would be cheaper, won't rid lake of all silt but can make enough usable water for coves.

New Business: W. Walker suggested changing our under-ground gas storage tank to an above-ground tank. He stated EPA is starting to monitor all under-ground storage tanks, there is no problem now but need to take out before any problems arise.

R. Reardon stated he will get more information on EPA standards and report at next meeting.

W. Walker reported that a new small heater is needed at maintenance shed. Decision was tabled until more information could be gathered.

A motion was made by T. Charles and seconded by R. Stansberry to sell an old C/B base to Robert Hall for \$10.00. Motion carried.

A. Tretter made a recommendation on a uniform and hat for patrolman to wear which gives a more professional and respectful look. With a logo on uniform and hat, the cost is approximately \$100. The Board agreed there was not any funds available for extra expenses, so Tretter stated he will donate a uniform and hat for patrolman.

Transfers: A motion made by T. Charles and seconded by R. Stansberry to accept for transfer Lot 14 Block 34, Meter #275 William Driver and Barbara Driver to Ronald C. Hallberg and Rhona C. Hallberg. Motion carried.

A motion was made by T. Charles and seconded by R. Stansberry to accept for transfer Lot 2 Block 25, Meter #190 William Helton and Lou Helton to Kenneth S. Phillips and Sandra K. Phillips. Motion carried.

A motion made by T. Charles and seconded by A. Tretter to adjourn the meeting. Motion carried.

Adjourned 9:30 p.m.

*Glenda M. Sutton*  
Secretary

SUNSET LAKE ASSOCIATION

MARCH 4, 1992

An executive Board of Director's meeting was held Wednesday, March 4, 1992 at 119 W. Madison, Girard. Pres. Frank Gibbons called meeting to order at 8:00 p.m. with the following Directors present: Frank Gibbons, Henry Sutton, Sharon Lindsay, Terri Charles, Al Tretter, Ray Stansberry and Ward Walker. Stuart Dobbs, attorney and Glenda Sutton were also present.

After some discussion concerning the finalization of the Snell case, a motion was made by R. Stansberry and seconded by A. Tretter to authorize the attorney to finalize the Snell court case through court action. Motion carried.

The attorney was also authorized to revise the present sanitation system affidavit for lease transfers.

A motion by T. Charles and a second by A. Tretter to adjourn meeting. Motion carried.

Adjourned 8:30 p.m.

*Glenda M. Sutton*

Secretary

PATROLMAN'S REPORT

MARCH, 1992

- Mar. 2 Burnt brush, picked up limbs in parks.  
3 Burnt leaves on West Lake Dr.  
4 Cleaned leaves in ditches and burnt.  
5 Burnt leaves North Lake Dr., cut and burnt dead trees.  
6 Leveled dirt for Terri Charles #7, cleaned up pile of dirt in front of John Earley #8 and piled brush across from Lot#121.  
9 Burnt brush, weather cold and rainy.  
10 Snowed.  
11 Cold and wet, worked on equipment.  
12 Worked in shop.  
13 Went to Carlinville, took Batchold mower to get repaired (new choke spring), got supplies - oil filters, new fuel hose for diesel tank.  
16 Burnt off leaves on Lot #49C and cleaned ditches.  
17 Picked up trash and burnt brush.  
18 Rained all day.  
19 Opened ditches and culverts.  
20 Lucile Murphy #250, A&B boat fell out of lift, called her and put it back.  
21 Hank Sutton and I looked at lots that need cleaning.  
23 Old boat dock floating in lake, took out and put on brush pile, cut it up because it was wet and rotten (Swifts?). Cut top out of barrel, will put trash barrel at bridge on North Lake road, people that fish off bridge throw trash in lake and along road, maybe this will help.  
24 Put new hose on diesel tank, put hooks on loader bucket and cleaned up shop.  
25 Burnt limbs and brush.  
26 Burnt dam off, burnt leaves on West Lake Dr.  
27 Cleaned ditches on corner of Jones land and burnt brush.  
30 It rained, opened up ditch that has water standing in them, drained water that stands in field west of shop and picked up trash.  
31 Pumped out barge and got ready to put Christmas trees in lake.

Bill Hohimer

SUNSET LAKE ASSOCIATION  
 PAST-DUE ACCOUNTS  
 APRIL 7, 1992

NAME	CURRENT ASSESSMENTS	PAST ASSESSMENTS	FINES & PENALTIES	MAINTENANCE COSTS	TOTAL PAST-DUE
Don Bunchman	\$ 115.17	\$ 433.65	\$ 31.57	\$ 218.75	\$ 799.14
Michael Carroll	121.35	-	-	-	121.35
John Cheek	127.53	-	-	-	127.53
Stephen Davidson	133.71	-	-	-	133.71
Bradley Drake	127.53	-	-	-	127.53
William Gray	133.71	161.14	35.47	-	330.32
Mark Homer	187.08	-	-	-	187.08
Wendell Jones	61.35	-	-	-	61.35
Michael Lindsay	133.71	-	-	-	133.71
Paul MacDonna	115.17	-	-	-	115.17
Howard McAnarney	187.08	-	-	-	187.08
Gary McLean	255.06	-	-	-	255.06
Keith Main	115.17	-	-	-	115.17
David Miller	66.71	-	-	-	66.71
Ronald Morrow	133.71	280.14	61.69	-	475.54
Nancy Standen	127.53	-	-	-	127.53
Robert Trapp	133.71	-	-	-	133.71
Bruce Weller	121.34	-	-	-	121.34
Charles Wooten	133.71	-	-	-	133.71
James Wyatt	133.71	723.14	195.21	-	1,052.06
John Zarr	133.71	161.14	30.63	-	325.48
	<u>\$ 2,797.75</u>	<u>\$ 1,759.21</u>	<u>\$ 354.57</u>	<u>\$ 218.75</u>	<u>\$ 5,130.28</u>



SUNSET LAKE ASSOCIATION

APRIL 7, 1992

Bills to be approved for payment:

Rural Electric Conv.	\$	134.16
Nilwood Water System		6.50
GTE - North	- 627-3232 - \$42.14	
	- 627-3339 - <u>33.62</u>	75.76
State Bank of Girard - petty cash		89.64
Stamped Envelope Agency - envelopes		160.00
Madiar-Holloway Insurance - audit on Workers Comp-	\$322.00	
	- audit on Gen. Liab. - <u>9.00</u>	331.00
Konneker-Brown, Inc. - repair on weedmower & parts		75.61
Secretary of State - dump truck license		192.00
Illinois Dept. of Conservation - boat registration fees		12.00
ADGPTV Water Commission - utilities		75.00
State Bank of Girard - Fed. & FICA Taxes		436.74
Illinois Dept. of Revenue - IL. W/H taxes		153.63
IL. Dept. of Employment Security - unemployment taxes		32.21
Baldwin Reporting Services - depositions		72.30
Glenda Sutton - net salary		365.51
William Hohimer- net salary		<u>1,072.78</u>
	Sub-Total	\$ 3,284.84
State Bank of Girard - petty cash		<u>15.74</u>
	Total	<u>\$ 3,300.58</u>

SUNSET LAKE ASSOCIATION

AGENDA

March 3, 1992

CALL TO ORDER

ROLL CALL

VISITORS' REMARKS

PATROLMAN'S REPORT

APPROVAL OF MINUTES OF February 4, 1992

APPROVAL OF BILLS

COMMITTEE REPORTS:

- AQUATIC CONTROL & RECREATION & WATER SAFETY - WARD WALKER
- BUILDING & CONSTRUCTION - TERRI CHARLES
- FARM MANAGEMENT - RAY STANSBERRY
- FINANCE - TERRI CHARLES
- LEGAL & LITIGATION - FRANK GIBBONS & AL TRETTER
- PUBLIC RELATIONS - SHARON LINDSAY
- ROADS & GROUNDS - HENRY SUTTON
- SANITATION, SHORELINE & BOAT DOCKS - DAVID MILLER
- WATER QUALITY, SOIL CONSERVATION & RESTORATION - RAY REARDON

OLD BUSINESS - Rules & Regulations fines changes & revisions  
- Newsletter

NEW BUSINESS

TRANSFERS: Lot 14 Block 34, Meter #275 William Driver & Barbara Driver  
to Ronald C. Hallberg & Rhonda C. Hallberg

Lot 2 Block 25, Meter #190 William Helton & Lou Helton  
to Kenneth S. Phillips & Sandra K. Phillips

TO: Board Director

FROM: Secretary

Please plan to attend the regular Directors meeting Tuesday,  
March 3, 1992 at 7:30 p.m. at 119 W. Madison, Girard (lake office).

SUNSET LAKE ASSOCIATION

MARCH 3, 1992

Bills to be approved for payment:

Rural Electric		\$ 137.88
Nilwood Water		6.50
GTE-North	- 627-3232 - \$41.44	
	- 627-3339 - 33.80	75.24
ADGPTV Water Commission	- utilities	75.00
State Bank of Girard	- Fed. W/H & FICA Taxes	450.79
Girard Chamber of Commerce	- annual dues	30.00
Daily Analytical Laboratories	- water sample testing	124.00
Lawrence Travis Co.	- corporate taxes prepared	450.00
Glenda Sutton	- net salary	365.53
William Hohimer	- net salary	1,072.78
State Bank of Girard	- petty cash	<u>12.94</u>
	Sub- Total	\$ 2,800.66
Ray Reardon	- postage for water samples	<u>28.60</u>
	Total	<u><u>\$ 2,829.26</u></u>

PATROLMAN'S REPORT

FEBRUARY 1992

- Feb. 3 Cut and Burnt limbs and brush.
- 4 Picked up trash, cans and bottles; trimmed low limbs on North Lake Dr. Board Meeting that evening.
- 5 Took truck to Jennings Chev. to fix ring on front wheels, they were taken off and discarded, service bulletin said they are not needed.
- 6 Talked to R.E.A. about trees that need to come down, most of the day was spent looking at trees around lake.
- 7 Started with R.E.A., cut and cleaned up one tree and brush.
- 10 Cut more brush.
- 11 Cold and wet, didn't do much, picked up cans and bottles on North Lake Dr.
- 12 Light snow, wet and cold.
- 13 R.E.A. cut trees, helped clean up.
- 14 Cut fire wood for Chuck Payne, charged \$35.00 for one load.
- 17-21 Cut and cleaned and raked up from trees cut by R.E.A., took 3,000 lbs. of chips to John Pintar, Lot #44, charged \$21.00, took truck to have front end relined, E.T. said it needs new lower ball joints before they could relined truck. Jennings said to wait a little longer on ball joints being replaced.
- 24 Picked up load of concrete blocks for weights for Christmas trees to put in lake, burnt brush.
- 25 Burnt brush.
- 26 Went to E.P.A. meeting on Otter Lake Atrazine problem, Ward Walker, Paul Erley also went, washed truck and waxed.
- 27 Cut dead trees and brush on North Lake Dr.

Bill Hohimer

SUNSET LAKE ASSOCIATION

APRIL 7, 1992

The regular Sunset Lake Board of Directors meeting was held Tuesday, April 7, 1992 at the lake office, 119 W. Madison, Girard. Pres. Frank Gibbons called the meeting to order at 7:30 p.m. with the following Directors present: Frank Gibbons, Terri Charles, Ray Stansberry, Henry Sutton, David Miller, Ward Walker, Ray Reardon, Sharon Lindsay and Al Tretter. Stuart Dobbs, William Hohimer and Glenda Sutton were also present.

Patrolman's Report: A motion made by R. Stansberry and Al Tretter to approve the March Patrolman's Report. Motion carried.

Minutes: A motion made by R. Stansberry and Ray Reardon to approve the regular March 3, 1992 and executive March 4, 1992 minutes as presented. Motion carried.

Bills: A motion made by R. Reardon and W. Walker approved for payment bills totaling \$3,300.58. Motion carried.

Aquatic Control & Recreation & Water Safety: W. Walker reported on more boating activity since warmer weather; patrol boat will be put in water in near future; a very predominant problem with muskrats, need to check dam area for any damage and also beaver damage.

R. Reardon discussed acquiring a nuisance trapping permit for beaver and muskrat and trapping them himself, could post warning signs locating traps so members could keep pets away from area, also will use same money program as approved earlier.

Walker stated he is monitoring the lake for weed problems and algae before deciding on spraying lake.

Gibbons suggested dropping lake level again this year. After some discussion on pros and cons, it was tabled until later.

Legal & Litigation: Stuart Dobbs, attorney, explained the sanitation affidavit form and transfer papers he drafted for Board's approval. He also revised the Sanitation Rule & Regulation Section 4 and added paragraph c. Dobbs talked to Macoupin County Health Dept. concerning their process of examining sanitation systems and on their procedure incorporated into Association's papers the same type of examining requirements before approval on transfers. He explained his revisions on Section 4, which will put the burden on the seller and buyer to see if sanitation systems are in working condition and comply with state, county rules and Sunset Lake Rules & Regulations. The County Health Dept. requires all septic plumbing in working condition which is his reason for adding that wording in Section 4, affidavits, sanitation riders and transfer instructional paper.

After reviewing forms, the following corrections and additions were suggested: on all forms that discuss plumbing, add the words, "waste water" before the word plumbing to explain type of plumbing; on seller's instruction papers, page 2 #8, change wording on sentence starting with "Contractors recognized" to state "You can find out if your contractor is qualified .....Department of Health in Carlinville."; on sanitation rider, change word "affluent" to "effluent"; agreed to cancel issuing membership cards; on Buyer's Instruction papers, page 1 #4, move margin on sentence starting "not cured prior" over under letter c for better understanding; on page 2 of Buyer's

April 7, 1992

Instructions, bottom line, change word "your" to "you" to correct word; last page of Buyer's Instructions, Acknowledgement by Purchaser, leave date "92" off form, leave blank line to be filled in when processed; on page 2 of Seller's Instructions, after #6 add paragraph saying "7. An executed consent form signed by your adjoining lot(s) owner(s).", change numbers to coincide with new paragraph; on transfer information paper, omit words "Annual Costs: \$ \_\_\_\_" and add office address and phone number at top of page.

A motion by T. Charles and seconded by R. Stansberry was made to accept all previously listed revisions on transfer papers and revision of Section 4 in rules and regulations. Motion carried.

Board discussed Association's insurance policies and the type of coverage. Attorney will examine and review coverages.

Attorney suggested Association adopt parliament rules for annual meetings, regular, special or any other such official meetings. Association could amend By-Law to adopt "Robert Rules of Order" at next annual or special membership meeting. Board agreed to add to next annual or special meeting agenda.

A motion by W. Walker and H. Sutton was made to accept for payment a bill from Stuart Dobbs in amount of \$2,865.00. Motion carried.

Building & Construction: T. Charles reported on building permits from Robert Hanauer #50 garage; William Hohimer #155, boat dock; Don Grider #41&#41A, new house; Don Jenkins #100&#100A, room addition; John Cheek #109 has submitted a permit for room addition, but she has not been able to approve yet.

Farm Management: R. Stansberry reported wheat farm crop is slowly looking better.

Finance: T. Charles will get budget committee together in near future.

Roads & Grounds: H. Sutton reported on checking culvert near Lot #7, looks fine, will monitor periodically; more stop signs being stolen, might need to purchase more; the 2-ton truck needs new brakes and battery, need to stop using or fix, Board agreed to have truck fixed for safety reasons; Hohimer stated 6,000 sq. ft. of free concrete is available when truck is fixed. Sutton reported on inspection of lots for general clean-up, made list of violators, but marked several off list as members have cleaned up lots, only 3 left on list; #79, Walter Jacober; #121 & #121A, Martha Humphrey; #85, #86&#88, Robert Berk, need letter sent to members notifying them of clean-up violation.

Sanitation, Shoreline & Boat Docks: D. Miller reported on receiving a sanitation permit from Jake's Plumbing to install an aeration sanitation system at Lot #2A Adolphe Codron. He asked Secretary to inform Jake's the permit is approved and installation could start.

Water Quality, Soil Conservation & Restoration: R. Reardon reported on Wm. Hohimer receiving a letter from EPA, he called EPA as letter was confusing. He found out that because of their participation in the secchi disk program, EPA could involve Association in program which will fund our water sample testing and laboratory analysis except for postage and shipping fees. Requires us to take water samples twice a year and mail to Champaign for lab work. They will mail us a video tape of instructions and containers for water samples.

A motion made by R. Reardon and S. Lindsay agreed to participate in EPA program. Motion carried.

Old Business: T. Charles reported on two 4-wheel vehicles being used on lake property which is a violation of Rules & Regulations.

A motion made by T. Charles and D. Miller requested a letter be mailed to John Earley #8 and Ron Morrow #2 giving notice of this violation restricting 4-wheel vehicles on lake property. Motion carried.

R. Reardon asked questions about gas storage tank. W. Walker reported it is a 500 gallon used tank. After some discussion, R. Stansberry suggested tabling matter until more information could be gathered.

R. Reardon asked who needs to be contacted concerning school bus turn-arounds on West Lake Dr., these will be needed soon. There was discussion on a turn-around also needed on East Lake Dr. but some roads are too narrow.

Gibbons appointed R. Reardon, H. Sutton and W. Walker on a committee to examine problem, contact school and report findings at a letter date.

A. Tretter showed patrolman's uniform examples, light blue shirt with IL. decal, flag & security decal on sleeve, dark blue pants and dark blue hat with Sunset Lake Security written on it.

New Business: Gibbons reported on REA asking members preference in keeping old mercury vapor security lights with rates changing from \$7.00 to \$8.75 or changing to the new high pressure sodium security light for a rate of \$7.25 a month. They also offered the chance to purchase the old mercury vapor lights for \$7.00 a piece.

A motion made by R. Stansberry and W. Walker to change to the new 100W high pressure sodium security lights and purchase the approximately 13 old mercury vapor lights for \$7.00 a piece. Motion carried.

T. Charles reported on Charles Jones #102, #102A & #102B building a fence without building permit or approval from Board.

After discussion, a motion was made by T. Charles and R. Stansberry to have Building Committee Chairperson notify Charles Jones #102, #102A & #102B to remove present fence as no permission was granted from Board. Motion carried.

Board discussed past-due accounts and agreed to table until next meeting for more discussion.

Transfers: A motion made by D. Miller and T. Charles to approve for transfer Lot 11, Block 24, Meter #179 Donald E. McAfee and Jeanette McAfee to Don, Yvonne and Patty Brockmeyer subject to an inspection by a qualified licensed contractor on present sanitation system with a letter from him stating whether passable or not, if does not pass inspection, an escrow of \$3500 will be held until new system can be installed. Motion carried.

A motion made by S. Lindsay and R. Stansberry to approve for transfer Lots 3&4, Block 19, Meters #135 & #135A Albert L. Rogers & Bonnie L. Rogers to Albert Rogers III and Diane Rogers. Motion carried.

A motion made by D. Miller and T. Charles to approve for transfer Lot 8, Block 15, Meter #110 Bob Jones and Elizabeth Jones to Robert A. Fish & Lois I. Fish subject to \$3500 escrow held for the installation of a new septic system. Motion carried.

A motion was made by T. Charles and H. Sutton to approve for

APRIL 7, 1992

transfer Lot 8, Block 3, Meter #12 Ron Wacker, Executor, to Kenneth J. Lazzaro subject to escrow being held in amounts of \$3500 for installation of new sanitation system, \$400 for 60' of shoreline repairs and \$100 for repair or removal of boat dock. Motion carried.

A motion made by D. Miller and H. Sutton to approve for transfer Lower part of Lot 21, Sunset Lake West property of Sunset Lake Association to Edward S. Snell and Delores Snell. Motion carried.

A motion by R. Stansberry and T. Charles was made to adjourn meeting. Motion carried.

Adjourned meeting 10:55 p.m.

*Glenda M. Sutton*

Secretary



PATROLMAN'S REPORT

APRIL, 1992

- Apr. 1 Took Christmas trees to boat dock to put in lake, worked on trying to start dump truck, can't get it started.
- 2 Put battery in dump truck and took to John Henry's to get brakes fixed. Jim Higginson, Mike Kaydus and I put Christmas trees in lake, made a map of trees put in lake and took to office.
- 3 Cleaned up after the trees, put used blocks in pile at the shed, took barge back out of water.
- 6 Cleaned up around shop, got mower inside to clean and paint, brought boat in to get ready, charged battery, spot painted boat and worked on wiring, lights and pump that didn't work.
- 7 Got pump switch and finished with boat, took heat houser off of tractor, took wire brush and cleaned mower to paint.
- 8 Charles Miller, Lot #58, had complaint about dogs in his yard, the dogs belong to Lot #52, Howard McAnarney and Charles & Donna Dodge, Lot #70A&B. I talked to each one and got the dogs tied up.
- 9 Picked up dump truck at John Henry's, painted mower, worked on gas powered tools, oiled, gassed & sharpened blades
- 10 Made sure that boat was OK, Ward & I put boat in water, took a "spring" look of the lake.
- 13 Rained, cleaned ditch and culverts.
- 14 Trimmed limbs, more ditches and picked up trash.
- 15 Rained all day, worked in shop.
- 16 Pumped out boat, cleaned leaves from ditches.
- 17 The dogs on the North side are still tied up. Someone has tied a pup to Howard McAnarney's dog house, the pup is a stray. Jim Black, Lot #36, called Ward and said that a deer head was floating by his boat dock, Ward and I went and got it and burnt it.
- 20 Need to start to mow, but is too muddy, started and tried all mowing equipment.
- 21 Rain, cold and windy, worked in shop.
- 22 Odd jobs, last time to clean up before mowing.
- 23 Started to mow in the afternoon, the ground is still muddy.
- 24 Raining and cold.
- 27 Fixed drain pipe on Beachview and opened ditch, picked up downed limbs.
- 28 Started to mow in afternoon, still very muddy.
- 29 Rain - mowing.

Jess James is giving us 6,000 sq. ft. of broken concrete for the hauling, this is clean, 3" thick and no wire.

Bill Hohimer

SUNSET LAKE ASSOCIATION

AGENDA

April 7, 1992

CALL TO ORDER

ROLL CALL

VISITORS' REMARKS

PATROLMAN'S REPORT

APPROVAL OF MINUTES OF March 3 & 4, 1992

APPROVAL OF BILLS

COMMITTEE REPORTS:

AQUATIC CONTROL & RECREATION & WATER SAFETY	-	WARD WALKER
BUILDING & CONSTRUCTION	-	TERRI CHARLES
FARM MANAGEMENT	-	RAY STANSBERRY
FINANCE	-	TERRI CHARLES
LEGAL & LITIGATION	-	FRANK GIBBONS & AL TRETTER
PUBLIC RELATIONS	-	SHARON LINDSAY
ROADS & GROUNDS	-	HENRY SUTTON
SANITATION, SHORELINE & BOAT DOCKS	-	DAVID MILLER
WATER QUALITY, SOIL CONSERVATION & RESTORATION	-	RAY REARDON

OLD BUSINESS- Revised and new sanitation affidavit & transfer papers

NEW BUSINESS - Changes in REA security light charges (See attached paper)

TRANSFERS: Lot 11 Block 24 Meter #179 Donald E. McAfee & Jeanette McAfee to Don, Yvonne & Patty Brockmeyer

Lots 3 & 4 Block 19 Meters #135 & #135A Albert L. Rogers & Bonnie L. Rogers to Albert Rogers III & Diana Rogers

Lot 8 Block 15 Meter #110 Bob Jones and Elizabeth Jones to Robert A. Fish & Lois I. Fish

Lot 8 Block 3 Meter #12 Ron Wacker, Executor, to Kenneth J. Lazzaro

TO: Lower part of Lot 21 Sunset Lake West to Ed & Delores Snell  
Board Directors

FROM: Secretary

Please plan to attend the Directors meeting Tuesday, April 7, 1992 at 119 W. Madison, lake office, Girard, starting at 7:30 p.m.

SUNSET LAKE ASSOCIATION  
 CASH POSITION  
 MARCH 31, 1992

Cash on Hand (petty cash)		\$ 100.00
State Bank of Girard		
Checking	\$ 200.77	
Money Market Fund - General	29,666.17	
- Interest	<u>92.78</u>	
		\$ 29,959.72
Prudential-Bache		<u>\$ 88.00</u>
Total General Revenue		\$ 30,147.72
State Bank of Girard		
Money Market Fund - Special (dam)	\$ 14,647.39	
- Interest	<u>53.37</u>	
		\$ 14,700.76
Total Revenue		<u>\$ 44,848.48</u>
State Bank of Girard (escrow)		<u>\$ 200.00</u>

Monthly Receipts:

Assessments		
- General	\$ 7,795.37	
- Island	35.00	
- Special	60.00	
Boat Permits	104.00	
Building Permits	100.00	
Fines & Penalties	72.57	
Transfer Fees	400.00	
Earned by Maintenance Man	37.50	
Misc. Income		
- Chlorine Tablets	32.00	
- C/B base	10.00	
- Farm Insur. dividend	<u>7.56</u>	
Total		<u>\$ 8,654.00</u>

SUNSET LAKE ASSOCIATION

MAY 5, 1992

The regular Sunset Lake Board of Directors' meeting was held Tuesday, May 5, 1992 at the lake office, 119 W. Madison, Girard. President Frank Gibbons called the meeting to order at 7:30 p.m. with the following Directors present: Henry Sutton, Frank Gibbons, Ray Reardon, Sharon Lindsay, Ray Stansberry and Al Tretter.

Patrolman's Report: A motion was made by R. Stansberry and seconded by A. Tretter to approve the April Patrolman's Report as presented. Motion carried.

Minutes: A motion was made by R. Reardon and seconded by R. Stansberry to approve the April 7, 1992 minutes with the following corrections: page 2, 1st paragraph, change the wording "your adjourning lot(s)" to "your adjoining lot(s)"; page 2, Water Quality report, change sentence from "water samples twice a year" to say "water samples once a month through May to October.". Motion carried.

Bills: A motion was made by S. Lindsay and seconded by A. Tretter to approve for payment bills totaling \$2,546.71. Motion carried.

Farm Management: R. Stansberry reported within the last 30 days the wheat crop has improved greatly. He also reported working with REA on a proposed installation of a primary power line along West Lake Dr., it would involve cutting six trees down around Stansberry's lot if above-ground wiring is installed. There were questions on possibility and cost of under-ground wiring installation. It was decided to ask for a written proposal from REA stating prices on above-ground and under-ground wiring installations before a decision can be finalized.

Public Relations: S. Lindsay reported on WSMI - Radio asking if Sunset Lake would want to participate in "Senior Salute" program honoring Girard's 1992 graduates at a cost of \$39. Board agreed not to participate in program as not financially recommended and not lake policy.

Roads and Grounds: H. Sutton reported on 100 ton of rip rap hauled and the borrowed barge from Otter Lake will soon be returned.

Water Quality, Soil Conservation & Restoration: R. Reardon called and confirmed with EPA the Asso. will be participating in the voluntary water testing program, they will be mailing material soon, Hohimer reported he received the secchi disk material.

Old Business: R. Reardon and H. Sutton reported on their study of possible school bus turn-arounds, they wanted to discuss options before presenting a plan to the school authorities. Sutton reported on possibly purchasing used guard rail from a Bluffs contractor, 150' of rail, 25 posts, curved rail end sections are needed with a possible cost of \$322.50 as we can install ourselves by state highway department standards. They will install between Lot #263 and Lot #264 on West Lake Dr. There was also discussion on possible delivery methods.

A motion by S. Lindsay and A. Tretter was made to allow H. Sutton and R. Reardon to continue working on project and purchase mat-

erial as they see fit and necessary to complete. Motion carried.

After Board reviewed past-due accounts, a motion was made by R. Reardon and A. Tretter to send a letter to all members with a past-due account asking for payment and explaining all lake privileges are suspended until account is cleared. Motion carried.

A. Tretter showed the new patches for the patrolman's uniform plus a badge.

R. Reardon reported on talking to Fire Chief, Gary Otten, concerning installing two dry hydrants on North side at a possible material cost of \$500 each, he will check further on project and report at a later date.

S. Lindsay asked Board's permission to install a small section of fence by their swimming pool for insurance purposes.

A motion made by H. Sutton and R. Reardon to approve the installation of a small fence near her pool. Motion carried.

F. Gibbons reported he and W. Walker agrees the present gas tank should be taken out of ground to deter any possible problems.

After some discussion, the Board decided to study more, get more information on cost before making any decisions.

Board discussed numbering the new Snell lots consecutively starting with #276 through #288 which follow Sunset Lake number system.

Board agreed to send a letter to Ralph and Mary Drake giving them a limited option to become Sunset Lake members.

Board proofread transfer instruction forms and contractor's inspection forms.

Corrections on contractor's form are as follows: front page, change "Inspection Proceedure (Septic/Sewage)" to "Inspection Procedure (Septic/Sewage)" and change "Inspection Proceedure (Waster-water Plumbing)" to "Inspection Procedure (Wastewater Plumbing)"; after both "Inspection Results" add the words, "This system meets the requirements of the Macoupin County Health Department, Yes \_\_\_ No \_\_\_"; on page 2, under State of Illinois, change wording to say, "I, \_\_\_\_\_, being duly sworn, state that I am a qualified contractor approved by Macoupin County Health Department and the information set forth in this form is true."

Correction on Seller's Instructions is as follows: page 2, #7 change word "contiguous lot" to "adjoining lot".

Correction on Buyer's Instructions are as follows: page 1, #4, move line that starts "not cured prior.....statement form" over under 4 (c); page 1, #4 (a) add the words "and/or boat dock" after "The shoreline" and any other place throughout form where needed; page 2, top line, add the word "estimated" in front of "cost to perform".

A motion was made by R. Stansberry and A. Tretter to approve the corrected transfer instructional forms and contractor's inspection form. Motion carried.

H. Sutton reported on several problems on storage spots for motor homes, boat trailers & etc. on Oak Lane, difficult for maintenance man to mow around. Sutton has made arrangements to have these items removed or replaced to eliminate the problem. He also

MAY 5, 1992

reported on a complaint from neighbor near Lot #154 on mowing violation, after examining area, did not find any violation.

R. Reardon reported on Ken Lazzaro, Lot #12 requesting to install a small fenced dog run, he showed a drawing of proposed fenced area.

A motion by R. Stansberry and S. Lindsay was made to approve the proposed fence dog run requested by Ken Lazzaro, Lot #12. Motion carried.

Transfer: A motion by R. Stansberry and R. Reardon was made to reverse the previous motion on Lot 8 Block 15, Meter #110 Bob & Elizabeth Jones which required a new sanitation system installed and change to state the presented contractor's inspection letter be accepted which states system is in working condition, therefore a new system is not required. Motion carried.

A motion by R. Stansberry and A. Tretter was made to adjourn the meeting. Motion carried.

Meeting adjourned at 10:00 p.m.

*Glenda M. Sutton*

Secretary

SUNSET LAKE ASSOCIATION

JUNE 2, 1992

Bills to be approved for payment:

Nilwood Water System		\$	6.50
Rural Electric Conv.			135.32
GTE-North	- 627-3232 - \$44.45		
	- 627-3339 - <u>33.31</u>		77.76
State Bank of Girard - Fed. W/H & FICA Taxes			436.77
Kenneth Deihl - Wyatt law suit			316.80
Macoupin Service Co. - unleaded fuel			402.53
Stamped Envelope Agency - large envelopes			160.00
Secretary of State - annual corporation report			5.00
ADGPTV Water Commission - utilities - \$ 75.00			
	- copy mach. <u>153.00</u>		
	(Maint.)		228.00
Farmers Mutual Hail Ins. Co. of Iowa - farm crop ins.			29.93
State Bank of Girard - petty cash			41.78
Glenda Sutton - net salary			365.50
William Hohimer - net salary			<u>1,072.76</u>
	Sub-Total	\$	3,278.65
Gold Nugget Publ. - office supplies			<u>44.89</u>
	Total	\$	<u><u>3,323.54</u></u>

PATROLMAN'S REPORT

MAY, 1992

- Apr. 30 Mowed all day on east side.
- May 1 Mowed North Lake Dr.
- 4 Started to load and haul concrete from Jess James, hauled 9 loads.
- 5 Hauled concrete - 10 loads.
- 6 Hauled 13 loads
- 7 Finished 7 loads plus one for Jess and one for Mick Stankoven.
- 8 Took dirt to Sharon Lindsay to fix wash outs on West side of dam. Also took some concrete to repair west end of cove. Getting ready to start to mow again.
- 11 Mowed West Lake Dr. and dam.
- 12 Mowed east side.
- 13 Moved dirt for Ray Fickas Lot #167, mowed at boat ramp. Loaded concrete on barge, 7 trips from shed with tractor.
- 14 Picked up two dogs, one went to pound, one went home (Elmore Hays' old place).
- 15 Complaint on more dogs, didn't get them, will try later. Pulled tree out of water on Lot #254A, Frances M. Clark. Moved more dirt for Ray Fickas.
- 18 Water test, mowed rest of day.
- 19 Mowed.
- 20 Ward & I put bouys in lake, trimmed with weed eater on West Lake.
- 21 Tried to catch 2 dogs on north side, cleaned up trash along roads.
- 22 REA change all lake lights, I went with them to number poles and pick up lights. We have 17 lights for sale. Mowed Lots 73,74.
- 24 Patrolled on Sunday, had a complaint on Lot #115. Mike DiDonato to fast in curve and hitting boat docks. Ward and I went out and found wrong sticker on boat. A motor on a no motor sticker, we gave a ticket and had him to go back in and change motor.
- 25 Memorial Day, very cold, not much on water. Took off at noon, my Grandmother past a way.
- 26 Funeral.
- 27 Picked concrete at Wayne McKinzie and used it at cove between Lots 121A and 122. Cleaned some brush and burnt, tried to catch 2 dogs on north side, 1 white dog and 1 black lab. The white dog will bite, I know. The dogs belong to Jim Black Lot #36.



( 2 )

- May 28 I talked to Jim Black about the dog problem. He said that they belonged to his son and he would tie them up or put in a pen, the son will get the dogs in about 3 weeks. I told him if dog is lose again, I would give a ticket and send the dogs to the pound.
- 29 Took bachtold mower to be worked on, hard to start and no power.
- 31 Patrolled, everyone was real good on water, first nice and warm day this year.

Bill Hohimer

SUNSET LAKE ASSOCIATION

AGENDA

May 5, 1992

CALL TO ORDER

ROLL CALL

VISITORS' REMARKS

PATROLMAN'S REPORT

APPROVAL OF MINUTES OF April 7, 1992

APPROVAL OF BILLS

COMMITTEE REPORTS:

AQUATIC CONTROL & RECREATION & WATER SAFETY	-	WARD WALKER
BUILDING & CONSTRUCTION	-	TERRI CHARLES
FARM MANAGEMENT	-	RAY STANSBERRY
FINANCE	-	TERRI CHARLES
LEGAL & LITIGATION	-	FRANK GIBBONS & AL TRETTEI
PUBLIC RELATIONS	-	SHARON LINDSAY
ROADS & GROUNDS	-	HENRY SUTTON
SANITATION, SHORELINE & BOAT DOCKS	-	DAVID MILLER
WATER QUALITY, SOIL CONSERVATION & RESTORATION	-	RAY REARDON

OLD BUSINESS - Past-Due Accounts

NEW BUSINESS - Contractor's Inspection form

TRANSFERS:

TO: Board of Directors

FROM: Secretary

Please plan to attend the regular Directors meeting on Tuesday, May 5, 1992 at lake office, 119 W. Madison, at 7:30 p.m.

SUNSET LAKE ASSOCIATION

MAY 5, 1992

Bills to approved for payment:

Nilwood Water		\$	6.50
GTE-North	- 627-3232	- \$45.48	
	- 627-3339	- <u>33.83</u>	79.31
Rural Electric Conv.			134.28
Rural Electric Conv.	- 17 old lights @\$7.00 each		119.00
Secretary of State	- Pick-up truck license		48.00
Girard Hardware	- paint & brush		20.25
State Bank of Girard	- Fed. W/H & FICA Taxes		436.77
State Bank of Girard	- petty cash		31.25
ADGPTV Water Commission	- utilities		75.00
Glenda Sutton	- net salary		365.51
William Hohimer	- net salary		<u>1,072.78</u>
	Sub-Total	\$	2,388.65
Gold Nugget Publ.	- office supply		20.36
Girard Auto Supply	- maintenance supply		17.70
Bank One, Springfield Trust-	bond redemption & interest		<u>120.00</u>
	Total	\$	<u><u>2,546.71</u></u>

SUNSET LAKE ASSOCIATION

CASH POSITION

APRIL 30, 1992

Cash on Hand (Petty Cash)		\$	100.00
State Bank of Girard			
Checking	\$	200.36	
Money Market Fund - General		28,693.16	
- Interest		<u>129.99</u>	
			\$ 29,023.51
Prudential-Bache			
Money Market Fund - General	\$	88.00	
- Interest		<u>1.00</u>	
			\$ <u>89.00</u>
Total General Revenue			\$ 29,212.51
State Bank of Girard			
Money Market Fund - Special (dam)	\$	14,700.76	
- Interest		<u>66.96</u>	
			\$ <u>14,767.72</u>
Total Revenue			\$ <u>43,980.23</u>
State Bank of Girard (escrow)			\$ <u>200.00</u>

Monthly Receipts:

Assessments	- General	\$	2,717.92
	- Island		70.00
	- Special		300.00
Boat Permits			111.00
Building Permits			320.00
Fines & Penalties			111.49
Transfer Fees			800.00
Earned by Maintenance Man			46.00
Misc. Income	- Chlorine Tablets		40.00
	- Membership		400.00
	- REA security light		7.00
	- hat		<u>4.00</u>

Total		\$	<u>4,927.41</u>
-------	--	----	-----------------

SUNSET LAKE ASSOCIATION

JUNE 2, 1992

The regular Board of Directors meeting was held Tuesday, June 2, 1992 at the lake office, 119 W. Madison, Girard. President Frank Gibbons called the meeting to order at 7:30 p.m. with the following Directors present: Ward Walker, Frank Gibbons, Terri Charles, Ray Reardon, Ray Stansberry, Sharon Lindsay, Henry Sutton and Al Tretter.

Visitor's Remarks: Weldon Stetter #214 was present to check on transfer of his property and to discuss the Association's park on Walnut Dr. His neighbor at #213 mows only half of park giving an unattractive appearance. He thought this should be maintained by maintenance man who is already doing a fine job.

Ray Aneloski #213 stated he mows part of park because he feels it should be mowed more often.

Board agreed as this is lake property, the maintenance man will be responsible for mowing this park area and residents should try to accept his busy schedule.

Aneloski also asked questions on new rule change, Section 4, b & c (Sanitation), Board explained contractor's inspection rule.

Patrolman's Report: A motion was made by S. Lindsay and T. Charles to approve the May Patrolman's Report. Motion carried.

Minutes: A motion was made by S. Lindsay and W. Walker to approve the May 5, 1992 minutes as presented. Motion carried.

Bills: A motion was made by S. Lindsay and A. Tretter to approve for payment bills totaling \$3,323.54 plus a bill from Ernie's Garage for a tire in the amount of \$11.50. Motion carried.

Aquatic Control & Recreation & Water Safety: W. Walker reported on running two secchi disk test with Paul Erley and Bill Hohimer which showed good results; issued a warning ticket to Mike DiDonato #215, #216, boat sticker displayed wrong; discussed possibility of stocking lake with small crappie and fat head minnows.

Building & Construction: T. Charles reported on the following building permits: Mike & Sharon Lindsay #216, extended boat dock; Laura Kimble #242, deck and storage shed; David Werry #217, covered boat house; Lorraine Sandage #147, dock extension; Louis & Jacqueline Woods #204, metal shed; Robert Berk #86, boat house; Raymond Fickas #167, garage; Robert Fish #110, room addition.

Farm Management: R. Stansberry showed wheat from farm crop, does not have growth he would expect at this time of year, but could improve if weather changes. He also explained his findings on the REA primary power line installation on West Lake Dr. It will be too costly to install lines underground for lot owners, so lines will be installed above ground, with only the loss of two big trees near his property. This will solve a power problem for now and for future uses.

Finance: T. Charles reported on budget Committee meeting being held to discuss 1993 Annual Budget, asked for committee's budget totals to be returned to her before next committee meeting. The next meeting was set for June 16, 1992 at 7:00 p.m.

Public Relations: S. Lindsay had no report, secretary suggested working on an informational letter to new members giving local utilities, schools, churches & etc.

Roads & Grounds: H. Sutton reported he, B. Hohimer and J. Earley returned Otter Lake's barge, some welding on barge might be required, a tire on trailer was damaged delivering the barge, so tire was repaired; agreed to have lots #73, #74 mowed by Hohimer due to neighbor's complaints; had seven tons of rip rap delivered to his property, will put charges on bill for payment; after some discussion on lots that need mowed, Board agreed to have Hohimer mow lots #94, #49C, #96 & #96A and mail statements to members.

Water Quality, Soil Conservation & Restoration: R. Reardon reported on EPA monitoring equipment and video have arrived, monthly material will be available for mailing samples as they are taken.

Old Business: W. Stetter suggested raising the annual assessments to cover expenses as money seems low at present and also thanked the Board for working together so favorably for the benefit of the Asso.

T. Charles asked about the unapproved fence installed on lots #102, #102A, #102B, Charles Jones. There was alot of discussion on types of fences and their uses and if any should be allowed at lake areas. The main problem was fences being installed without Board's approval.

A motion was made by R. Reardon and seconded by R. Stansberry to send letters to Charles Jones #102, #102A & #102B and Mary Dopp #108 informing them to remove their unapproved fences or attend Board meeting for possible approval. Motion carried.

W. Walker asked about status of underground gas tank.

R. Reardon stated that the expenses for the removal of this tank have not been budgeted for this year.

A motion was made by T. Charles and S. Lindsay to table matter until R. Reardon can gather more information and report by next meeting. Motion carried.

R. Reardon reported on still getting information on dry hydrants, will get total amounts later; explained LaVern Harvey #242 place has been cleaned up which will please neighbor and help the sale of her property; also reported on walking dam area for evidence of beaver and muskrat problems, he could find none at this time.

New Business: T. Charles reported boating rules are being ignored, need more friendly reminders possibly in local paper.

W. Walker stated several shorelines are in need of repair, especially around lot #20, he will talk to committee chairperson about inspecting shorelines and making list to report at next meeting.

Secretary reported pastdue accounts are paid in full except two accounts have paid partial payments with arrangements made to get accounts paid in full plus one account is still unpaid.

Transfers: A motion was made by T. Charles and S. Lindsay to approve for transfer Lot 3-D Block 2, Meter #10 Earl K. Haynes to Patrick J. Wilkin and Debra K. Wilkin subject to \$100 escrow being held to

cover expenses on removing a broken apple tree near road. Motion carried.

A motion was made by S. Lindsay and R. Stansberry to approve for transfer Lots 5 & 5A Block 14, Meters #101 & #101A Anna Mae Schlicht to Edward Burg and Bernadine Burg. Motion carried.

A motion was made by T. Charles and R. Reardon to approve for transfer Lot 2 Block 18, Meter #126 Edward J. Burg and Bernadine M. Burg to Robert E. Groesch and Shelly L. Stevens. Motion carried.

A motion was made by R. Stansberry and T. Charles to approve for transfer Lot 11 Block 27, Meter #214 Weldon G. Stetter and Jane Stetter to Gary Yaris and Patty Yaris subject to all proper paper work being approved. Motion carried.

A motion was made by T. Charles and R. Stansberry to approve for transfer Lot 3 Block 33 Norma Walter to William A. Lenzi and Nancy Lenzi subject to all committee's approvals and proper paper work approved. Motion carried.

A motion by T. Charles and R. Stansberry was made to adjourn the meeting. Motion carried.

Adjournment 10:10 p.m.

*Glenda M. Sutton*

Secretary

SUNSET LAKE ASSOCIATION

PATROLMAN'S REPORT

JUNE 1992

- JUN. 1 Took water test, got complaint on Jim Black's dogs, I talked to him.
- 2 Worked equipment, sharpened mower, changed oil in tractor and ser., took weed mower to be worked on.
- 3 Mowed our part of the divided dam on North Lake Dr., mowed some around ponds and picked up brush and burnt.
- 4 Had complaint on Jim Black's #36 dog, gave Black a ticket, he said he would keep them tied up. Worked on getting everything ready for summer help.
- 5 Picked up trash, sold 2 lights to S. Lindsay & R. Stansberry.
- 7 Patrolled lake, gave a ticket to Mike DiDonato for motor on boat with wrong sticker and speeding in and out of cove.
- 8 Summer help started. Cleaned up burn pile on Oak Lane and Walnut and corner of Tom Turnbull #138. Started mowing and trimming.
- 9 Mowed, got a call from Norine Smith Lot #32 that Jim Black's dog was bothering grandchild in the lake, went and got dog and sent to the dog pound.
- 10 Mowed and Tony (summer help) trimmed.
- 12 Jim Black's dog is back and is tied up. Mowed all day.
- 14 Patrolled lake, most everyone was OK, some paddle boats had to be push back into coves, two boats had to be towed in - out of gas.
- 15 Need mower and weed eater parts, mowed all day and trimmed.
- 16 Worked on Lots that need mowed, mowed at the dam, got Roundup to spray dam, finished most of the mowing.
- 17 Serviced truck and mowers, trimmed limbs that are in the road, got a call from Mrs. Fisher Lot #223 that dogs on Beachview were a problem, went and talked to Bill Gray, need to see Don Burgess.
- 18 Cleaned up burn piles, took tickets and cash to office, washed truck. I talked to Don Burgess.
- 19 Mowed Lot 99-99A Hampton, mowed around ponds, Ward and I patrolled lake, stopped five boats.
- 21 Patrolled lake, stopped three paddle boats out in lake too far.
- 22 Mowed Lots 21,21A,22 Keith Day, mowed grass in back of pond in front of Earl Haynes, took tickets to office.
- 24 Sprayed rip rap at the dam and started mowing bank, moved a little rip rap between Lots 121A,122, about  $\frac{1}{2}$  truck load, washed tractor and cleaned it up, sent stray pup to dog pound (black female), picked up on Sunset Dr., no tags.



- 25 Mowed on dam, cleaned around shop, got paint for fuel tank, cleaned and wire brushed fuel tank.
- 26 Patrolled lake from 10:00 till 12:00, burnt two small brush piles, one on West Lake and one on North Lake Dr., speed sign on West Lake Dr. has been run over and tore up, we need some new signs.
- 28 Patrolled lake, good many boats on water, some of the Board members need to read rule book and to set an example.
- 29 Mowed at dam, Tony helped with water samples, I mowed at the dam, got a call from Mrs. Charles Miller Lot #58 wondering when we were going to spray lake, Tony painted fuel tank and rear tractor blade.
- 30 Finished dam and started to remove places that need it.

Bill Hohimer

# A barrel of trouble

By CHARLENE FINCK and SUSAN DAVIS

**D**on Daley thought he was being a good citizen when he notified the state fire marshal's office that he had a 2,500-gal. and a 1,000-gal. tank with diesel fuel buried on his Lakeview, Ohio farm.

He wanted the local fire department to know the location of the tanks in case of a fire. There hasn't been a fire, but the sparks started flying when Daley received a bill for an annual \$150 tank registration fee from a local board that oversees underground fuel storage. The message with the bill—pay up or be fined up to \$1,000.

The Underground Storage Tank (UST) fees in Ohio, as in many states, are used to provide \$1 million of insurance with a \$50,000 deductible for containment and cleanup.

Daley and his son Bert feel farmers can police their own tanks without having the government play marshal. When they didn't pay up, the compen-

sation board sent a \$1,000 late-fee fine.

They appealed, with no results. Their attorney advised them to dig up the 2,500-gal. tank (tanks under 1,100 gal. are exempt from federal rules—unless they leak). Daley agreed and spent about \$300 having the seven-year-old tank set on top of the ground, sidestepping the \$1,000 fine.

Doing that might not solve all his problems, though. After notifying the underground storage board that he now had an aboveground tank, the state fire marshal's office sent a form and a \$25 annual registration fee. Even though federal regulations for aboveground tanks are still being discussed, some states already have rules in place.

**Like many farmers accustomed to having buried tanks, Daley was blindsided by laws he didn't even know existed. He pulls out a meticulous manila folder recording every phone call**

and document over the last two years. In addition to those expenses, he ended up paying \$300—the \$150 yearly registration fees for 1989 and 1990.

Compared with farmers who have had leaking tanks, Daley got off cheap. Still, it's not easy sorting through the red tape wrapped around underground storage tanks. A federal Underground Storage Tank program started in 1984 provides specifications for tank closure, leak detection, corrosion protection and spill/overflow prevention provisions (see table).

Underground farm and residential tanks for fuel or heating oil that are less than 1,100 gal. are exempt from federal regulations but may be subject to state laws. (States must be at least as stringent as the feds; often they are more strict.) Since state requirements vary widely, the only way to be certain of what they are is to call your Regional Environmental Underground Storage Tank Office (see map).

Farm tanks have generally escaped the wrath of strict state regulations—so far. Most states target suppliers and outlets. "Suppliers are going to be told that they can't deliver fuel to someone who isn't in compliance," explains T.J. Shambaugh, who follows the issue from a dual perspective—both as an Oakley, Ill., farmer and a contractor who removes underground tanks.

That's already happening in Iowa. Petroleum distributors are required to report to the Department of Natural Resources (DNR) if a registration tag isn't present on a fill pipe.

Although farmers with tanks smaller than 1,100 gal. are exempt from federal regulations, they are still at risk if the tank leaks. That leaves them more vulnerable than if the tank were covered under the rules, because tanks that

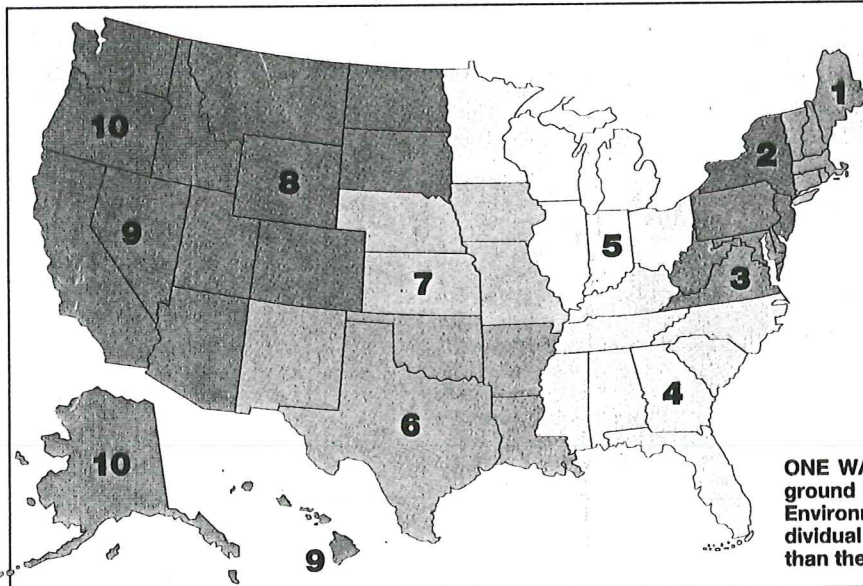

## WHERE TO CALL

- Region 1: ..... **617-573-9604**
- Region 2: ..... **212-264-3384**
- Region 3: ..... **215-597-7354**
- Region 4: ..... **404-347-3866**
- Region 5: ..... **312-886-6159**
- Region 6: ..... **214-655-6755**
- Region 7: ..... **913-551-7651**
- Region 8: ..... **303-293-1514**
- Region 9: ..... **415-744-2082**
- Region 10: ..... **206-553-1643**

**ONE WAY TO LEARN** the requirements for underground tanks in your state is to call your Regional Environmental Underground Storage Tank Office. Individual state laws vary widely and may be stricter than the federal law.

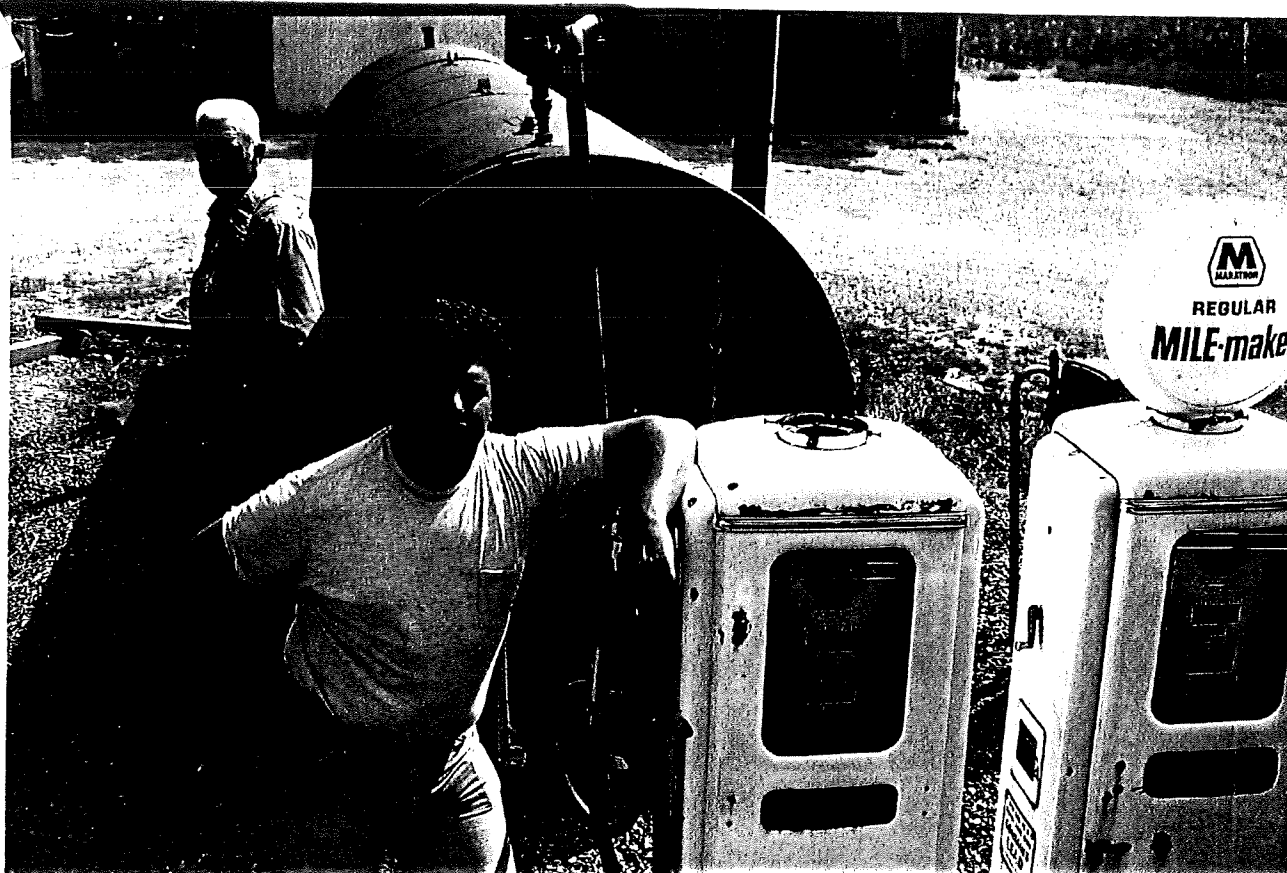

PHOTO: SUSAN DAVIS

don't fall under the EPA's rules aren't eligible for federal disaster funds to defray cleanup costs, even though EPA can require a cleanup.

Tanks more than 10 years old and made of steel have the highest potential for leaking, although there's no way to predict when problems will occur. A tank could be damaged during installation and start leaking right away.

The stakes are high. Cleanups can easily cost several thousand dollars. That's not to mention the possible damage to the farm's water supply. "It only takes 1 gal. of gasoline to contaminate 750,000 gal. of drinking water," says Jim McCaslin, acting director of petroleum and chemical safety in Illinois.

You also want to check your insurance policy. Farmers often think they have coverage for leaks or spills, but many policies contain a pollution exclusion, says Sammy Ny, branch chief in the EPA's national UST office.

**Soil tests can spot or confirm** a leak, but you also may notice some signs such as discolored soil, the odor of fuel, excess water in the tank or irregularities in the pump's operation.

If you suspect a problem, contact someone certified to deal with underground storage tanks. "We recommend an engineering firm or some independent to do the soil testing," says Shambaugh, who works with Underground Tank Removal out of Cerro Gordo, Ill. "It will cost about \$25 to \$30 per cubic yard to remove contaminated soil. With a process that expensive, you want an impartial party making the judgment on how much goes."

Cleanups can be accomplished a couple ways. The most common is to dig up the tank and the contaminated soil. The dirt then gets trucked to the local landfill. The tank owner retains responsibility and liability even after the soil is in the landfill.

Another cleanup technique is called "farming" the soil. This places the contaminated dirt in a bermed area with a waterproof liner next to the dig site. Once it's in the berm, a disk or other tillage tool is used to work it every few days. The air and heat from the sun gradually cleanse the soil until it can be put back into the original hole.

The farming method is usually cheaper. However, the soil is still classified as contaminated and can never

**AFTER BATTLING GOVERNMENT** agencies for two years, Don Daley and his son Bert finally had their underground storage tank moved above ground.

be moved from the site (unless it goes to a landfill).

Digging up and disposing of a leaking tank requires someone certified to handle the job. Shambaugh cautions farmers about whom they hire. The tank removal business is new enough that competition is slim and "even some of the big guys try to skirt the law." ◀

"Musts for USTs" is available from your state regulatory agency or write: EPA, Office of Underground Storage Tanks, Washington, D.C. 20460.

### FEDERAL DEADLINES (for tanks over 2,500 gal.)

Type of tank and piping	Leak detection	Corrosion protection	Spill/Overfill prevention
<i>New tanks and piping*</i>	At installation	At installation	At installation
<i>Existing tanks** Installed:</i>	By no later than:	} December 1998	} December 1998
Before 1965 or unknown	December 1989		
1965 - 1969	December 1990		
1970 - 1974	December 1991		
1975 - 1979	December 1992		
1980 - December 1988	December 1993		
<i>Existing piping**</i>			
Pressurized	December 1990	December 1998	Does not apply
Suction	Same as existing tanks	December 1998	Does not apply

\*Installed after December 1988 \*\*Installed before December 1988

SOURCE: "MUSTS FOR USTs," AN EPA GUIDE

# A barrel of trouble

By CHARLENE FINCK and SUSAN DAVIS

**D**on Daley thought he was being a good citizen when he notified the state fire marshal's office that he had a 2,500-gal. and a 1,000-gal. tank with diesel fuel buried on his Lakeview, Ohio farm.

He wanted the local fire department to know the location of the tanks in case of a fire. There hasn't been a fire, but the sparks started flying when Daley received a bill for an annual \$150 tank registration fee from a local board that oversees underground fuel storage. The message with the bill—pay up or be fined up to \$1,000.

The Underground Storage Tank (UST) fees in Ohio, as in many states, are used to provide \$1 million of insurance with a \$50,000 deductible for containment and cleanup.

Daley and his son Bert feel farmers can police their own tanks without having the government play marshal. When they didn't pay up, the compen-

sation board sent a \$1,000 late-fee fine.

They appealed, with no results. Their attorney advised them to dig up the 2,500-gal. tank (tanks under 1,100 gal. are exempt from federal rules—unless they leak). Daley agreed and spent about \$300 having the seven-year-old tank set on top of the ground, sidestepping the \$1,000 fine.

Doing that might not solve all his problems, though. After notifying the underground storage board that he now had an aboveground tank, the state fire marshal's office sent a form and a \$25 annual registration fee. Even though federal regulations for aboveground tanks are still being discussed, some states already have rules in place.

**Like many farmers accustomed to having buried tanks, Daley was blindsided by laws he didn't even know existed. He pulls out a meticulous manila folder recording every phone call**

and document over the last two years. In addition to those expenses, he ended up paying \$300—the \$150 yearly registration fees for 1989 and 1990.

Compared with farmers who have had leaking tanks, Daley got off cheap. Still, it's not easy sorting through the red tape wrapped around underground storage tanks. A federal Underground Storage Tank program started in 1984 provides specifications for tank closure, leak detection, corrosion protection and spill/overflow prevention provisions (see table).

Underground farm and residential tanks for fuel or heating oil that are less than 1,100 gal. are exempt from federal regulations but may be subject to state laws. (States must be at least as stringent as the feds; often they are more strict.) Since state requirements vary widely, the only way to be certain of what they are is to call your Regional Environmental Underground Storage Tank Office (see map).

Farm tanks have generally escaped the wrath of strict state regulations—so far. Most states target suppliers and outlets. "Suppliers are going to be told that they can't deliver fuel to someone who isn't in compliance," explains T.J. Shambaugh, who follows the issue from a dual perspective—both as an Oakley, Ill., farmer and a contractor who removes underground tanks.

That's already happening in Iowa. Petroleum distributors are required to report to the Department of Natural Resources (DNR) if a registration tag isn't present on a fill pipe.

Although farmers with tanks smaller than 1,100 gal. are exempt from federal regulations, they are still at risk if the tank leaks. That leaves them more vulnerable than if the tank were covered under the rules, because tanks that

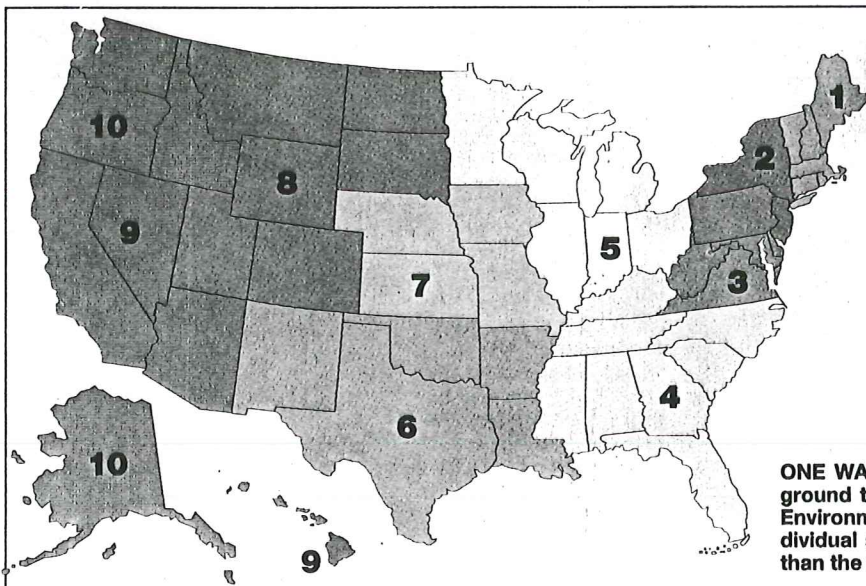

## WHERE TO CALL

- Region 1: ..... **617-573-9604**
- Region 2: ..... **212-264-3384**
- Region 3: ..... **215-597-7354**
- Region 4: ..... **404-347-3866**
- Region 5: ..... **312-886-6159**
- Region 6: ..... **214-655-6755**
- Region 7: ..... **913-551-7651**
- Region 8: ..... **303-293-1514**
- Region 9: ..... **415-744-2082**
- Region 10: ..... **206-553-1643**

**ONE WAY TO LEARN** the requirements for underground tanks in your state is to call your Regional Environmental Underground Storage Tank Office. Individual state laws vary widely and may be stricter than the federal law.



PHOTO: SUSAN DAVIS

don't fall under the EPA's rules aren't eligible for federal disaster funds to defray cleanup costs, even though EPA can require a cleanup.

Tanks more than 10 years old and made of steel have the highest potential for leaking, although there's no way to predict when problems will occur. A tank could be damaged during installation and start leaking right away.

The stakes are high. Cleanups can easily cost several thousand dollars. That's not to mention the possible damage to the farm's water supply. "It only takes 1 gal. of gasoline to contaminate 750,000 gal. of drinking water," says Jim McCaslin, acting director of petroleum and chemical safety in Illinois.

You also want to check your insurance policy. Farmers often think they have coverage for leaks or spills, but many policies contain a pollution exclusion, says Sammy Ny, branch chief in the EPA's national UST office.

**Soil tests can spot or confirm a leak,** but you also may notice some signs such as discolored soil, the odor of fuel, excess water in the tank or irregularities in the pump's operation.

If you suspect a problem, contact someone certified to deal with underground storage tanks. "We recommend an engineering firm or some independent to do the soil testing," says Shambaugh, who works with Underground Tank Removal out of Cerro Gordo, Ill. "It will cost about \$25 to \$30 per cubic yard to remove contaminated soil. With a process that expensive, you want an impartial party making the judgment on how much goes."

Cleanups can be accomplished a couple ways. The most common is to dig up the tank and the contaminated soil. The dirt then gets trucked to the local landfill. The tank owner retains responsibility and liability even after the soil is in the landfill.

Another cleanup technique is called "farming" the soil. This places the contaminated dirt in a bermed area with a waterproof liner next to the dig site. Once it's in the berm, a disk or other tillage tool is used to work it every few days. The air and heat from the sun gradually cleanse the soil until it can be put back into the original hole.

The farming method is usually cheaper. However, the soil is still classified as contaminated and can never

**AFTER BATTLING GOVERNMENT agencies for two years, Don Daley and his son Bert finally had their underground storage tank moved above ground.**

be moved from the site (unless it goes to a landfill).

Digging up and disposing of a leaking tank requires someone certified to handle the job. Shambaugh cautions farmers about whom they hire. The tank removal business is new enough that competition is slim and "even some of the big guys try to skirt the law." ◀

"Musts for USTs" is available from your state regulatory agency or write: EPA, Office of Underground Storage Tanks, Washington, D.C. 20460.

### FEDERAL DEADLINES (for tanks over 2,500 gal.)

Type of tank and piping	Leak detection	Corrosion protection	Spill/Overfill prevention
<i>New tanks and piping*</i>	At installation	At installation	At installation
<i>Existing tanks** installed:</i> Before 1965 or unknown 1965 - 1969 1970 - 1974 1975 - 1979 1980 - December 1988	By no later than: December 1989 December 1990 December 1991 December 1992 December 1993	} December 1998	} December 1998
<i>Existing piping**</i> Pressurized Suction	December 1990 Same as existing tanks		
*Installed after December 1988 **Installed before December 1988			

SOURCE: "MUSTS FOR USTs," AN EPA GUIDE

SUNSET LAKE ASSOCIATION

AGENDA

June 2, 1992

CALL TO ORDER

ROLL CALL

VISITORS' REMARKS

PATROLMAN'S REPORT

APPROVAL OF MINUTES OF May 5, 1992

APPROVAL OF BILLS

COMMITTEE REPORTS:

AQUATIC CONTROL & RECREATION & WATER SAFETY	-	WARD WALKER
BUILDING & CONSTRUCTION	-	TERRI CHARLES
FARM MANAGEMENT	-	RAY STANSBERRY
FINANCE	-	TERRI CHARLES
LEGAL & LITIGATION	-	FRANK GIBBONS & AL TRETTER
PUBLIC RELATIONS	-	SHARON LINDSAY
ROADS & GROUNDS	-	HENRY SUTTON
SANITATION, SHORELINE & BOAT DOCKS	-	DAVID MILLER
WATER QUALITY, SOIL CONSERVATION & RESTORATION	-	RAY REARDON

OLD BUSINESS

NEW BUSINESS

TRANSFERS: Lot 3-D Block 2 Meter #10 Earl K. Haynes to Patrick J. Wilkin and Debra K. Wilkin

Lots 5 & 5A Block 14 Meters #101 & #101A Anna Mae Schlicht to Edward Burg and Bernadine Burg

Lot 2 Block 18 Meter #126 Edward J. Burg and Bernadine M. Burg to Robert E. Groesch and Shelly L. Stevens

Lot 11 Block 27 Meter #214 Weldon G. Stetter and Jane Stetter to Gary Yryis and Patty Yryis

Lot 3 Block 33 Norma Walter to William A. Lenzi & Nancy Lenzi

SUNSET LAKE ASSOCIATION  
CASH POSITION  
MAY 31, 1992

Cash on Hand (petty cash)		\$ 100.00
State Bank of Girard		
Checking	\$ 201.46	
Money Market Fund - General	27,844.70	
- Interest	81.31	
		\$ 28,127.47
Prudential-Bache		
Money Market Fund - General		\$ 89.00
Total General Revenue		\$ 28,316.47
State Bank of Girard		
Money Market Fund - Special (dam)	\$ 14,767.72	
- Interest	42.48	
		\$ 14,810.20
Total Revenue		\$ 43,126.67
State Bank of Girard (escrow)		\$ 200.00

Monthly Receipts:

Assessments		
- General	\$ 916.37	
- Island	35.00	
Boat Permits	59.00	
Building Permits	155.00	
Fines & Penalties	90.61	
Transfer Fees	400.00	
Earned by Maintenance Man	111.57	
Misc. Income		
- Chlorine Tablets	8.00	
hats	16.00	
Total		\$ 1,791.55

SUNSET LAKE ASSOCIATION

JULY 7, 1992

The regular Board of Directors meeting was held Tuesday, July 7, 1992 at the lake office, 119 W. Madison, Girard, IL. President Frank Gibbons called the meeting to order at 7:30 p.m. with the following Directors present: Henry Sutton, Terri Charles, Ray Reardon, Ward Walker, Ray Stansberry, Sharon Lindsay, Al Tretter and Frank Gibbons.

Visitor's Remarks: Charles Jones #102, #102A, #102B was present to discuss receiving a letter from Board of Directors concerning erecting a fence on his property without Board's approval. He presented an album showing pictures of the alleged fence constructed out of trellis material. He explained the reasons for building the fence/trellis; for the safety of the children in the area and to designate parking area, plus the trellis which is only 3-4 feet high is decorated with flowers. As he considered this structure as nothing more than a flower trellis which also served in several other ways, he did not realize permission was needed. He apologized for not seeking Board approval earlier and asked Board's permission to keep the trellis, as it is an asset to his property.

After Board reviewed the album of pictures and considered C. Jones' request, a motion was made by R. Stansberry and seconded by A. Tretter to approve the fence/trellis as constructed. Motion carried with four yes and three no.

Mary Dopp #108 was present to explain why she extended a trellis beyond the area she previously had permission to construct. She stated her son extended the trellis because of the neighbor's children running around the sheds which could prove to be dangerous and annoying. She showed pictures of trellis before constructing intention and after construction, explaining why she would like to keep trellis there for looks and safety reasons. She apologized for her son erecting this trellis without permission, but hoped Board would see it's merits and approve construction.

After some discussion, Board agreed to table until next meeting until Board members could view the area before any decision is made.

Mary Dopp also asked about constructing a dog run. Board told her to bring plans showing dimensions and materials to Board for approval.

Patrolman's Report: A motion was made by H. Sutton and seconded by R. Stansberry to approve the June Patrolman's Report as presented. Motion carried.

Minutes: A motion by S. Lindsay and seconded by R. Stansberry was made to approve the June 2, 1992 minutes as presented. Motion carried.

Bills: A motion was made by R. Reardon and seconded by R. Stansberry to approve for payment bills totaling \$6,654.74. Motion carried.

Aquatic Control & Recreation & Water Safety: Ward Walker reported on taking two secchi tests and one EPA water sample for the month; called Dept. of Conservation for removal of ducks and geese from lake, they do not have funds for this type of program; reviewed boating rules, many members speeding on slow speed days plus Board members not obeying rules which makes stressing rules to other members difficult, recommended rescheduling ski hours to start and stop at



same time to eliminate confusion.

Building & Construction: T. Charles reported on the following building permits: Pat Wilkins #10, new house; Robert Foster #194, storage shed; Gene Roseberry #33, covered boat dock; Jim Perry #26, deck; Lee Rule #222, covered boat dock; William Harris #106, addition to room; Loyd James #19, room addition; Charles recommended sending letter to Ron Morrow #2 notifying him of a triple permit fee fine as he is building a deck without an approved permit.

After some discussion, a motion was made by T. Charles and seconded by R. Stansberry to send letter to Ron Morrow #2 notifying him of an assessment of a \$90 fine for constructing a deck on property without an approved building permit. Motion carried.

Public Relations: S. Lindsay reported on a verbal complaint from Jeanette Clark #117 stating neighbors #115 & #116 moved a shed then built up area around shed which relocated the water drainage and is washing out an area on Clark's property. Board agreed to investigate matter and report at next meeting.

Roads & Grounds: H. Sutton stated not very busy, discussed delivery of guard rail.

Sanitation, Shoreline & Boat Docks: F. Gibbons appointed W. Walker to oversee committee in Dave Miller's absence which is due to his work schedule.

Old Business: R. Stansberry reported on cost of new REA primary power lines; \$1,200 cost for 400' of underground lines, \$3.00 per foot cost to install back to individual houses, electrician needed for hook-up to house; need to inform other property owners about cost and ask their opinion if they are willing to cover expenses. Board agreed to table until owners could be contacted.

R. Reardon suggested installing one dry hydrant near dry pond on North Lake Dr. at an approximate cost for material of \$570 plus installation cost, he estimated \$700 be budgeted for this expense.

R. Reardon also discussed the pros and cons of keeping gas tank underground; he talked to EPA Dept. and State Fire Marshall about coded and regulations.

After much discussion on matter, a motion was made by R. Stansberry and seconded by T. Charles to budget \$2,000 to cover expenses on the extraction and disposal underground gas tank. Motion carried.

A motion by H. Sutton and seconded by R. Stansberry was made to amend the previous motion to include using up the present gas supply, then cap tank and stop using until tank can be removed. Motion carried.

R. Reardon stated K. Lazzaro #12 suggested moving the "No Wake" sign located near his shoreline to other side of cove to help his beach area. Board agreed to have maintenance man handle this matter.

F. Gibbons presented the proposed 1993 Budget for discussion.

After much discussion, it was decided to table approval of 1993 Budget until next meeting.

JULY 7, 1992

A motion was made by R. Reardon and seconded by R. Stansberry to have the equipment reserve fund be kept in a separate bank account from the general fund and only used in emergency cases upon approval from Board starting with the 1993 Budget.

New Business: R. Stansberry suggested selling Sunset Lake property as lots for extra revenue. One problem is there is no lake assess or any easements available on lake property. Board agreed to table for more study.

T. Charles suggested purchasing larger boat sticker numbers to display on boats for better viewing during violations, very difficult to see present ones. Board decided to study further and discuss at another meeting.

Transfers: A motion was made by S. Lindsay and seconded by T. Charles to approve for transfer Lot 2 Block 19, Meter #136 Walter Gilchrist and Loretta Gilchrist to Clarence G. McKinney and Shelby J. McKinney.

A motion by S. Lindsay and seconded by R. Stansberry was made to approve for transfer Lot 3A Block 4 Meter #19 James Getchel and William Getchel to Loyd James and Donna James and Lot 4 Block 4, Meter #18 Daniel Lee Morgan and Mary L. Morgan to Daryle L. Williamson and Nancy R. Williamson. Motion carried.

A motion was made by S. Lindsay and seconded by R. Stansberry to approve for transfer Lot 10 Block 19, Meter #130 Bruce Weller and Linda Weller to Henry Smith and Peggy Smith subject to \$100 escrow being held for shoreline rip rap. Motion carried.

A motion was made by H. Sutton and seconded by T. Charles to amend the Weller #130 transfer motion to add \$4,000 escrow being held for a new sanitation system to be installed. Motion carried.

A motion was made by S. Lindsay and seconded by R. Stansberry to approve the transfer of Lot 6A Block 33 Meter #247 Hilda Justison to Bruce Weller subject to \$500 be held in escrow for shoreline rip rap. Motion carried.

Meeting adjourned at 10:40 p.m.

*Glenda M. Sutton*

Secretary

PATROLMAN'S REPORT

JULY, 1992

- July 1 Finished mowing and trimming for the 4th of July.
- 2 I went and got power steam cleaner from Tony's dad and cleaned old dump truck, grease on motor 1 to 2 inches thick, filled gas tanks for the boats.
- 3 Storm last night had a lot of limbs and trees to clean up. A lot of trash on roads, water went over roads in several places, 3 7/10 rain, put the lake back full. Patrolled in afternoon.
- 4 Patrolled lake, most everything OK, some fisherman and paddle boats had to be moved back.
- 5 Rain and lightning, lightning struck a tree at Lot #248, helped clean brush out of lake. At the same place was a carp fish almost dead, weight was 47 lb., it had 2 gallons of eggs in it. Rose Avart call, dead grass carp in her bay, 39 inches long. Buried it.
- 6 Cleaned up trash and limbs from Friday's storm.
- 7 Tony didn't work. Lot #253, Vincent Zerante needs concrete rip rap, took 1 1/3 loads to him, help lay with the tractor his rock, rip rap charge was \$147.50.
- 8 Tony didn't work again, burnt brush piles on West Lake, trimmed limbs over roads.
- 9 Tony was back, didn't want to work so sent him home and called Ill. Valley Program. He was putting down time he hadn't worked. Mowed West side of dam with weed eater most of the day. A call on Terri Charles' dogs from Norine Smith Lot #32.
- 10 Mrs. Smith called again, Jim Black's dog is loose, went and had him to tie it up.
- 12 Patrolled lake.
- 13 Two dead grass carp in bay of Lots #38 & #41. Cut limbs over road & burnt, put up "No Wake" sign at the lake side of Lot #120, put 2 new "No Wake" signs at the dam, helped take water samples.
- 14 Our gas tank is empty, took electric line up so as not to be used. Rained, cleaned shop, took chain saw to be worked on, will move 15 tons of sand for Ray Reardon tomorrow.
- 15 Norine Smith called, Black's dog is loose again. 1 hour plus of work for Ray - charged \$25.00, talked on phone to Jeanette Clark for 1/2 hour about Water washing off of Lot #115 & #116. Mike DiDonato Lots #115, #116 called and talked for over a hour about dirt washing, rip rap and lake rules in the water, he is very understanding, he wants advise on what to do with water problem and shoreline. He will talk to his neighbors and Hank and me later.
- 16 Talked to Black again about dogs, burnt more brush on North side.

- 17 Rained, took day off in afternoon.
- 19 Patrolled
- 20 Put new blades on bush hog, spot sprayed dam again, went and got chain saw from shop.
- 21 Rain storm last night, had limbs to pick up.
- 22 Started to put rip rap down at the dam at Lots #38 - #41, this bank is very steep, Tony is not much help.
- 23 More work with rip rap, rained us out.
- 24 Talked to Mike DiDonato again, will meet Saturday afternoon. In afternoon, helped set up Festival Days.
- 25 Met with DiDonato and Blankenship, Hank, Ward, Frank and myself.
- 26 Patrolled lake in morning, picked up trash from last night, storm left 2½ inches of rain.
- 27 Trimmed trees on corner of Circle Dr across from Lot #19. Took water test, called REA, tree limb on wire at the turn around at Al Moores
- 28 Started mowing agin, Tony trimming.
- 29 Mowed all day.
- 30 Stormed again, tree and limbs down, cleaned up, got call from Norine Smith, called Black, dog is loose, took 1 load of rip rap to Lot #252 and #253, will charge later.
- 31 Worked on this report, will see Black.

Bill Hohimer

SUNSET LAKE ASSOCIATION

CASH POSITION

JULY 31, 1992

Cash on Hand (petty cash)		\$	100.00
State Bank of Girard			
Checking	\$	1.44	
Money Market Fund - General		24,751.44	
- Interest		<u>91.03</u>	
			\$ 24,843.91
Prudential-Bache			
Money Market Fund - General	\$	89.00	
- Interest		<u>1.00</u>	
			\$ <u>90.00</u>
Total General Revenue			\$ 25,033.91
State Bank of Girard			
Money Market Fund - Special (dam)	\$	14,727.98	
- Interest		<u>53.14</u>	
			\$ <u>14,781.12</u>
Total Revenue			\$ <u><u>39,815.03</u></u>
State Bank of Girard - (escrow)			\$ <u><u>4,300.00</u></u>
Monthly Receipts:			
Assessments - General	\$	-0-	
- Island		-0-	
Boat Permits		73.00	
Building Permits		100.00	
Fines & Penalties		25.00	
Transfer Fees		800.00	
Earned by Maintenance Man		231.25	
Misc. Income - Wheat		3,119.70	
- Chlorine Tablets		16.00	
- Hats		8.00	
- Escrow		<u>4,100.00</u>	
Total			\$ <u><u>8,472.95</u></u>

SUNSET LAKE ASSOCIATION

AUGUST 4, 1992

Bills to be approved for payment:

Rural Electric Conv.		\$ 163.90
GTE-North	- 627-3232 - \$47.79	
	- 627-3339 - <u>34.40</u>	82.19
Baldwin Reporting Service - Wyatt case (deposition)		81.30
Girard Hardware	- paint, pad lock, bolts & nuts	33.59
State Bank of Girard - Fed. W/H & FICA Taxes		436.77
ADGPTV Water Commission - utilities		75.00
State Bank of Girard - petty cash		16.48
Glenda Sutton	- net salary	365.51
William Hohimer	- net salary	1,072.78
Gold Nugget	- lease forms & building permits	<u>160.10</u>
	Total	\$ 2,487.62

SUNSET LAKE ASSOCIATION

AGENDA

July 7, 1992

CALL TO ORDER

ROLL CALL

VISITORS' REMARKS

PATROLMAN'S REPORT

APPROVAL OF MINUTES OF June 2, 1992

APPROVAL OF BILLS

COMMITTEE REPORTS:

AQUATIC CONTROL & RECREATION & WATER SAFETY	-	WARD WALKER
BUILDING & CONSTRUCTION	-	TERRI CHARLES
FARM MANAGEMENT	-	RAY STANSBERRY
FINANCE	-	TERRI CHARLES
LEGAL & LITIGATION	-	FRANK GIBBONS & AL TRETTEI
PUBLIC RELATIONS	-	SHARON LINDSAY
ROADS & GROUNDS	-	HENRY SUTTON
SANITATION, SHORELINE & BOAT DOCKS	-	DAVID MILLER
WATER QUALITY, SOIL CONSERVATION & RESTORATION	-	RAY REARDON

OLD BUSINESS - 1993 Budget review

NEW BUSINESS

TRANSFERS: Lot 2, Block 19 Meter #136 Walter Gilchrist & Loretta Gilchrist to Clarence G. McKinney & Shelby J. McKinney.  
Lot 3A Block 4 Meter #19 James Getchel & William Getchel to Loyd James & Donna James  
Lot 4 Block 4 Meter #18 Daniel Lee Morgan & Mary L. Morgan to Daryle L. Williamson & Nancy R. Williamson  
Lot 10 Block 19 Meter #130 Bruce Weller & Linda Weller to Henry Smith & Peggy Smith  
Lot 6A Block 33 Meter #247 Hilda Justison to Bruce Weller

SUNSET LAKE ASSOCIATION

JULY 7, 1992

Bills to be approved for payment:

Girard Post Office	- box rental	35.00
ADGPTV Water Commission	- office supplies	\$ 59.58
Ward Walker	- chemicals - copper sulfate	165.71
Rural Electric Conv.		164.02
Nilwood Water System		6.50
GTE-North	- 627-3232 - \$44.72	
	- 627-3339 - <u>33.72</u>	78.44
State Bank of Girard	- Fed W/H & FICA Taxes	436.79
Illinois Department of Revenue	- IL. W/H Taxes	153.63
Opel's Fish	- crappie & minnows for lake	1,000.00
Macoupin County Collector	- 1991 Real Estate Taxes	2,335.18
Tom Day Business Machine	- typewriter ribbons	39.10
Konneker-Brown, Inc.	- mower & weed eater parts & repairs	231.82
Macoupin County Clerk	- dog pound charges	15.00
Nelson Oil Co.	- chlorine tablets (50#)	151.93
Macoupin Service Co.	- Roundup chemicals for dam	124.82
Illinois Director of Employment Security	- unemployment	32.21
ADGPTV Water Commission	- utilities	75.00
State Bank of Girard	- petty cash	13.97
Glenda Sutton	- net salary	365.51
William Hohimer	- net salary	<u>1,072.78</u>
	Sub-Total	\$ 6,556.99
Nilwood Water	- June	<u>7.75</u>
	Total	<u>\$ 6,654.74</u>



SUNSET LAKE ASSOCIATION

CASH POSITION

JUNE 30, 1992

Cash on Hand (petty cash)		\$	100.00
State Bank of Girard			
Checking	\$	200.25	
Money Market Fund - General		26,559.34	
- Interest		<u>78.40</u>	
			\$ 26,837.99
Prudential-Bache			
Money Market Fund - General			<u>\$ 89.00</u>
Total General Revenue			\$ 27,026.99
State Bank of Girard			
Money Market Fund - Special (dam)	\$	14,810.20	
- Interest		<u>42.60</u>	
			<u>\$ 14,852.80</u>
Total Revenue			<u>\$ 41,879.79</u>
State Bank of Girard - (escrow)			<u>\$ 200.00</u>

Monethly Receipts:

Assessments	- General	\$	496.36	
	- Island		35.00	
Boat Permits			74.00	
Building Permits			180.00	
Fines & Penalties			74.22	
Transfer Fees			800.00	
Earned by Maintenance Man			121.25	
Misc. Income.	- Chlorine tablets		69.00	
	- Security light		7.00	
	- Membership		<u>400.00</u>	
Total				<u>\$ 2,256.83</u>

SUNSET LAKE ASSOCIATION  
AUGUST 21, 1992

A regular meeting of Board of Directors was held August 21, 1992 at St. Patrick's Church Meeting Hall, West Center & 8th Sts., Girard. President Frank Gibbons opened the meeting at 9:36 p.m. with the following Directors present: Frank Gibbons, Sharon Lindsay, Ward Walker, Ray Reardon, Henry Sutton, Mike DiDonato and John Earley.

Minutes: A motion was made by S. Lindsay and seconded by W. Walker to approve the minutes of August 4, 1992 subject to correcting paragraph 4 under Visitor's Remarks by adding the word "approximately" before figure 1/3 to state "property by approximately 1/3". Motion carried.

Bills: A motion was made by J. Earley and seconded by R. Reardon to approve for payment bills totaling \$4,310.59. Motion carried.

President F. Gibbons made the following Committee appointments:

Aquatic Control, Recreation & Water Safety	- Ward Walker - Chairperson - Ray Stansberry - Committee
Building & Construction	- Mike DiDonato - Chairperson - Sharon Lindsay - Committee
Farm Management	- John Earley - Chairperson - Henry Sutton - Committee
Finance	- Sharon Lindsay - Chairperson - Frank Gibbons - Committee
Legal & Litigation	- Frank Gibbons - Chairperson - Al Tretter - Committee
Public Relations	- Sharon Lindsay - Chairperson - Mike DiDonato - Committee
Roads & Grounds	- Henry Sutton - Chairperson - John Earley - Committee
Sanitation, Shoreline & Boat Docks	- Ray Stansberry - Chairperson - Bill Hohimer - Committee
Water Quality, Soil Conservation & Restoration	- Ray Reardon - Chairperson - Ward Walker - Committee

Old Business: The subject of Dennis Meeker #215 lot division plan was tabled until next meeting for more study.

New Business: Board agreed to change the next regular meeting date to Thursday, September 10, 1992 starting at 7:30 p.m.

Transfer: A motion was made by H. Sutton and seconded by John Earley to approve for transfer Lot 1, Block 7A, Meter #49A Larry A. McDuffee and Doris A. McDuffee to Jeffery L. Zellmer and Clarice M. Zellmer. Motion carried.

After some discussion, a motion was made by R. Reardon and seconded by H. Sutton to table the transfer of property of David and Marsha Miller #270A until next meeting so Board can examine shoreline before final approval of escrow amount is decided for repairs. Motion carried.

Meeting adjourned at 10:09 p.m.

*Glenda M. Sutton*  
Secretary

SUNSET LAKE ASSOCIATION

AUGUST 21, 1992

An Organizational meeting of Board of Directors was held Friday, August 21, 1992 at the St. Patrick's Church Meeting Hall, Girard, with the meeting opening at 9:30 p.m.

Nominations were opened for officers for the pursuing year 1992-1993.

A motion by Henry Sutton and Sharon Lindsay was made to nominate Frank Gibbons for the office of President. Motion carried.

A motion by Sharon Lindsay and Henry Sutton was made to close the nominations. Motion carried.

A motion by Ward Walker and Henry Sutton was made to nominate Ray Reardon for the office of Vice-President. Motion carried.

A motion by Ward Walker and Henry Sutton was made to nominate Sharon Lindsay for treasurer. Motion carried.

The new officers for 1992-1993 year are as follows: President, Frank Gibbons; Vice-President, Ray Reardon; Treasurer, Sharon Lindsay.

A motion was made by Sharon Lindsay and seconded by John Earley to rehire the present employees, William Hohimer as Patrolman/Maintenance Man and Glenda Sutton as Secretary. Motion carried.

Meeting adjourned 9:35 p.m.

*Glenda M. Sutton*

Secretary

SUNSET LAKE ASSOCIATION

Comparison of Annual Budget  
For Period From January 1, 1992 to September 10, 1992

	<u>Annual</u> <u>Budget</u>	<u>Year</u> <u>To</u> <u>Date</u>	<u>Over</u> <u>or (Under)</u> <u>Budget</u>
RECEIPTS:			
General Assessments	\$ 38,690.00	\$ 37,812.69	\$ (877.31)
Bulding Permits	400.00	940.00	540.00
Fines & Penalties	300.00	417.89	117.89
Farm Income	2,500.00	3,172.06	672.06
Interest	3,500.00	1,062.19	(2,437.81)
Transfer & Lease Fees	2,800.00	4,400.00	1,600.00
Boat Permits (Year 2 of 2 yr.Per.)	2,000.00	491.00	(1,509.00)
Cablevision	1,300.00	1,226.24	(73.76)
Earned by Maintenance Man	500.00	967.82	467.82
Other Receipts	400.00	281.00	(119.00)
	<u>                    </u>	<u>                    </u>	<u>                    </u>
Total Revenue	<u>\$ 52,390.00</u>	<u>\$ 50,770.89</u>	<u>\$ (1,619.11)</u>

EXPENDITURES:

Patrol/Maint. Man's Salary	\$ 16,065.00	\$ 12,048.75	\$ (4,016.24)
Secretary's Salary	5,407.50	4,055.61	(1,351.89)
Legal & Accounting Fees	4,000.00	3,785.40	(214.60)
Office Rent	900.00	675.00	(225.00)
Postage, Printing & Office Exp.	1,800.00	1,233.37	(566.63)
Maintenance: Lake	1,000.00	173.37	(826.63)
Roads	1,000.00	-0-	(1,000.00)
Grounds	1,000.00	178.20	(821.80)
Equipment	1,800.00	1,204.30	(595.70)
Conservation	2,000.00	-0-	(2,000.00)
Gas & Oil	1,800.00	1,266.88	(533.12)
Maintenance Expense & Supplies	200.50	46.65	(153.85)
Farm Expense	250.00	469.23	219.23
Fish Stocking	1,000.00	1,000.00	-0-
Utilities	2,500.00	1,853.49	(646.51)
Insurance	4,867.00	2,941.00	(1,926.00)
Employment Taxes	1,750.00	1,394.83	(355.17)
Property Taxes	2,050.00	2,335.18	285.18
Misc., Interest, Mileage & Etc.	500.00	869.14	369.14
Equipment Reserve	2,500.00	-0-	(2,500.00)
	<u>                    </u>	<u>                    </u>	<u>                    </u>
Total Expenditures	<u>\$ 52,390.00</u>	<u>\$ 35,530.40</u>	<u>\$ (16,859.59)</u>

SUNSET LAKE ASSOCIATION  
SEPTEMBER 10, 1992

Bills to be approved for payment:

Girard Hardware	- tape, fuel tank parts	\$ 17.92
Girard Auto Supply	- maintenance equip.	6.96
Stamped Envelope Agency	- envelopes	317.00
Macoupin Service Co.	- farm chemicals & spraying	446.86
Macoupin County Animal Control	- Black's dog pound charge	<u>15.50</u>
	Sub-Total	\$ 804.24
Macoupin Service Co.	- grass seed for Island	28.20
Smoky Jennings Chev.	- truck repair	125.36
Nilwood Water System		<u>7.75</u>
	Total	\$ 965.55

PATROLMAN'S REPORT

AUGUST, 1992

- Aug. 2 Patrolled
- 3 At Lot #253, Vincent Zerante, worked 1 hour on tractor work moving rip rap, started rip rap at North Lake dam.
- 4 Cut and burnt brush from over roads at the corner of Lot #19-20, hauled rip rap on north side.
- 5 Took rip rap to H. Prentice Lot #252, fixed hole where gas tank was, set up overhead tank for gas, put filters on tanks and hose and nozzle.
- 6 Mowed all day, stormed late afternoon.
- 7 Got a call that Terri Charles' dogs were at C. Smith's house Lot #32, picked up and took home. Cleaned up limbs in afternoon.
- 8 Looked at #115 lot water problem.
- 9 Patrolled.
- 10 Helped with water test, mowed rest of day.
- 11 Took 1 load of rip rap to Lot #252 and 1 hour of tractor work, then mowed.
- 12 Mowed, took underground tank and pump back to Nifong in Palmyra. Cleaned around shop, made appointment for truck for new ball joints, warrenty worked.
- 13 Mowed at dam.
- 14 Went to Mother-in-Law's funeral.
- 16 Patrolled.
- 17 Took truck to get new ball joints, took  $\frac{1}{2}$  load of rip rap to Lot #252.
- 18 Mowed.
- 19 Took 1 scoop of chips to Rose Avart Lot #24, called Sheriff for extra help during annual meeting, got Gene James' truck, went and got guard rails at Bluff, IL.(doubled order - free).
- 20 Frank, Ward & I looked at D. Miller #270A shoreline, Ward & I look at shoreline along the west side that needs rip rapped. Mowed dam at Lots #263-264 West Lake Dr.
- 21 Helped set up chairs for meeting and speakers, patrolled.
- 22 Ray S., Sharon L. & I looked at D. Miller's Lot #270A shoreline.
- 23 Patrolled.
- 24 Did water test in afternoon, laid 15 tons of rip rap at Lot #252 and 2 hours of tractor work.

- 25 Mowed boat ramp and trimmed.
- 26 Burnt brush, trimmed and mowed.
- 27 Mowed, storm in late afternoon, 3" rain.
- 28 Cleaned culverts, picked up limbs, Mae Ess' road needs repair, large hump in middle of road, car drags.
- 29 Hank, Frank & I looked at drainage problems around lake, looked at corner of Jonesland, can't see around corner. Will repair road at end of East Lake Dr.
- 30 Patrolled in morning.
- 31 Mowed, cut back weeds at corner of Jonesland.
- Sept 1 Mowed all day, picked up Jim Black's dog again, called pound.

Bill Hohimer

# 1993 Crop No till Soybeans Alternatives

## Expenses

	<u>10020</u>
Fall burndown	\$ 400
Spring Herbicide	\$ 950
No-till drilling	\$ 280
Harvesting	\$ 616
Seed	\$ 500
Fertilizer	\$ 420
	<u>\$ 3166</u>

## 50/50 Crop Share

	\$ 200	
	\$ 475	
	- 0 -	Tenant Responsible
	- 0 -	Tenant Responsible
	\$ 250	
	<u>\$ 210</u>	
	\$ 1085	
	<u>1130</u>	

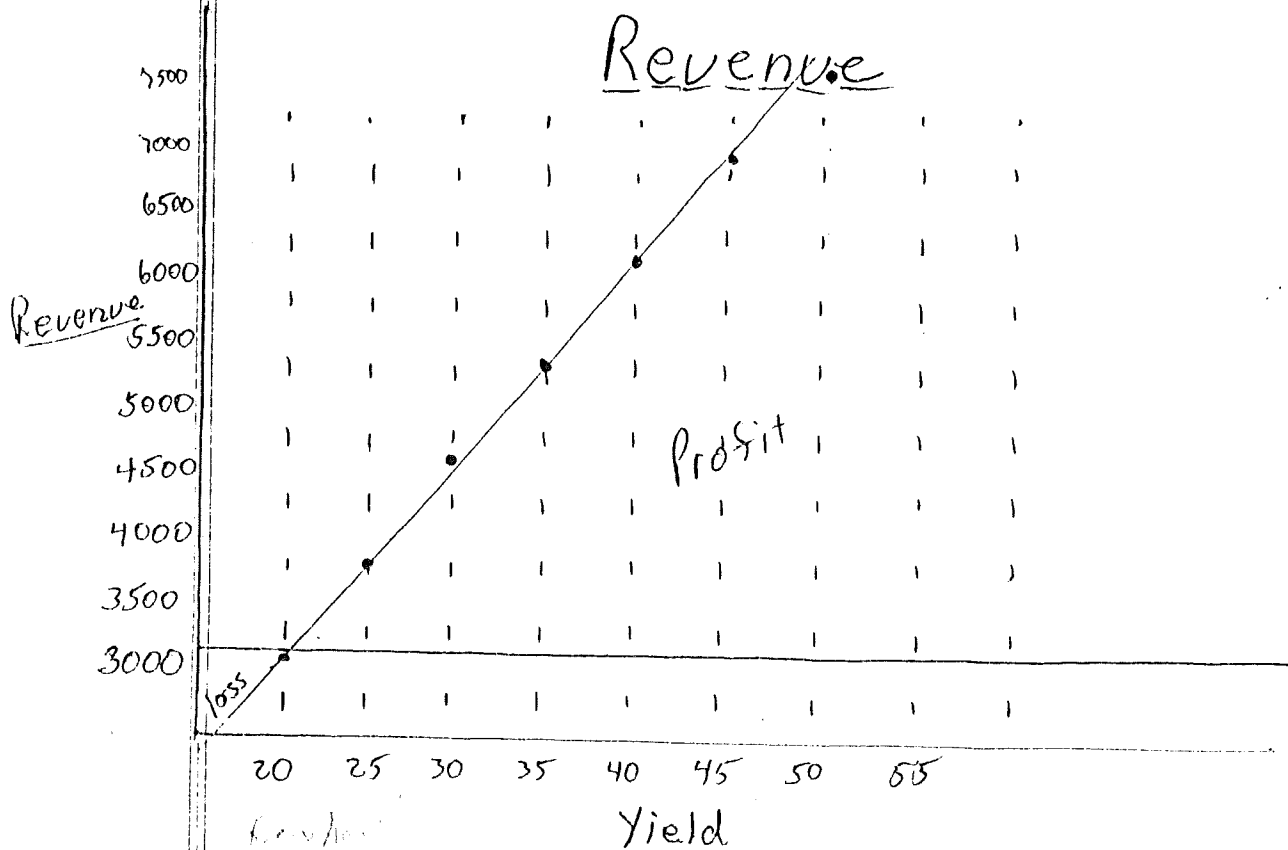



# Crown Vetch

Price/lb      \$10 <sup>40</sup>/<sub>lb</sub>    in 10<sup>#</sup> bags

Rate    15 lbs/acres

or    3000 sq ft/lb on seed    max.

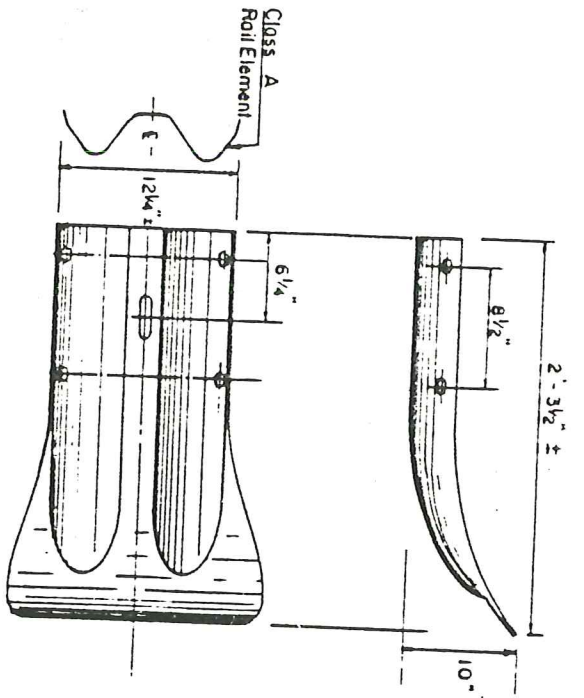

**END SECTION**

**NOTE:**  
 End Section shall be used only when specified on the contract plans.  
 Cost included in the bid unit price for Guard Roll.

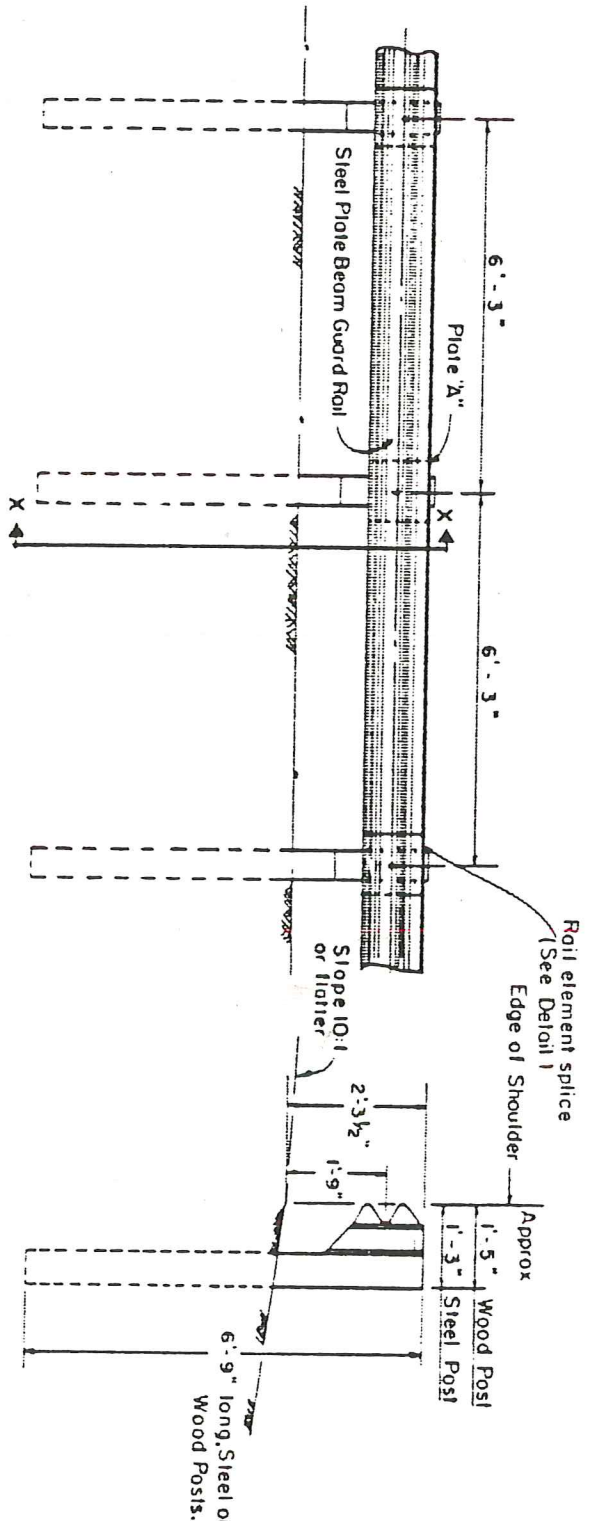

**SECTION X-X**

**BLOCK-OUT DETAILS**

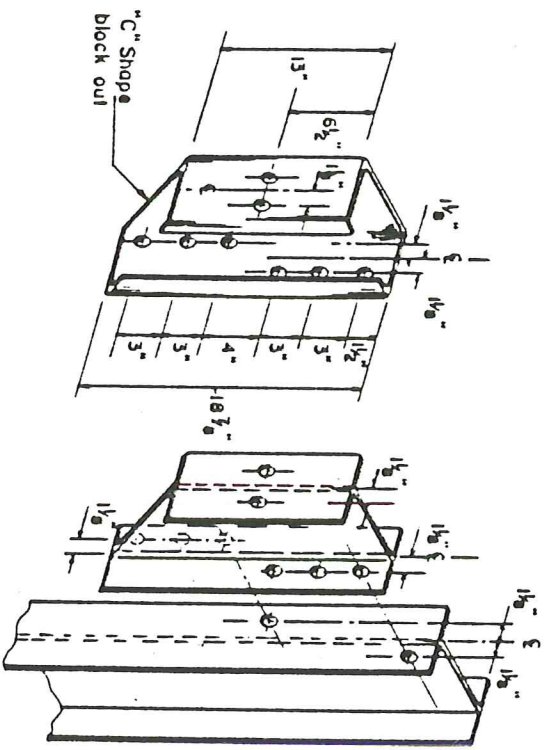

**TYPE A**  
 (6'-3" Typical Post (cing))

SUNSET LAKE ASSOCIATION

AGENDA

August 21, 1992

CALL TO ORDER

ROLL CALL

VISITORS' REMARKS

PATROLMAN'S REPORT

APPROVAL OF MINUTES OF August 4, 1992

APPROVAL OF BILLS

COMMITTEE REPORTS:

AQUATIC CONTROL & RECREATION & WATER SAFETY	-	WARD WALKER
BUILDING & CONSTRUCTION	-	TERRI CHARLES
FARM MANAGEMENT	-	RAY STANSBERRY
FINANCE	-	TERRI CHARLES
LEGAL & LITIGATION	-	FRANK GIBBONS & AL TRETTER
PUBLIC RELATIONS	-	SHARON LINDSAY
ROADS & GROUNDS	-	HENRY SUTTON
SANITATION, SHORELINE & BOAT DOCKS	-	DAVID MILLER
WATER QUALITY, SOIL CONSERVATION & RESTORATION	-	RAY REARDON

OLD BUSINESS - Meeker #215 Lot division

NEW BUSINESS - Next regular meeting date

TRANSFERS: Lot 1 Block 7A Meter #49A Larry A. McDuffee and Doris A. McDuffee to Jeffery L. Zellmer and Clarice M. Zellmer

SUNSET LAKE ASSOCIATION

AUGUST 21, 1992

Bills to be approved for payment:

Rural Electric Conv.		\$ 164.40
Nilwood Water System		7.75
GTE-North	- 627-3232 - \$43.18	
	- 627-3339 - <u>36.17</u>	79.35
Madiar-Holloway Insurance Ag.	- Bond - \$ 200.00	
	- Auto - <u>1,196.00</u>	1,396.00
Cindy's Flowers & Gifts	- flowers	53.13
Macoupin Service Co.	- fuel tank filters & fuel	507.94
ADGPTV Water Commission	- utilities - \$75.00	
	- address cards <u>13.98</u>	88.98
State Bank of Girard	- petty cash	63.00
State Bank of Girard	- Fed W/H & FICA	436.77
St. Patrick's Church	- rental on building	75.00
Glenda Sutton	- net salary	365.50
William Hohimer	- net salary	<u>1,072.77</u>
	Total	\$ 4,310.59

SUNSET LAKE ASSOCIATION

AUGUST 4, 1992

The regular Board of Director's meeting was held Tuesday, August 4, 1992 at the lake office, 119 W. Madison, Girard, IL. President Frank Gibbons called the meeting to order at 7:30 p.m. with the following Directors present: Frank Gibbons, Sharon Lindsay, Ray Reardon, Henry Sutton, Ward Walker, Ray Stansberry, Al Tretter and David Miller.

Visitor's Remarks: Mary Dopp #108 was present to discuss if Board had made a decision on the construction of an extended trellis on her property which was done without a permit.

Several Board Directors reported on viewing the trellis in question.

After some discussion, a motion was made by R. Reardon and seconded by A. Tretter to allow the extended trellis to stay as constructed at Mary Dopp #108 property because it was more of an advantage than a detriment. Motion carried.

Dennis Meeker #215 was present to ask Board if they would consider splitting his lot into two lots which would be beneficial to Association by establishing another Class "A" Membership. He showed a diagram of his proposed plan. The plan showed dividing his 1.2 acres of property by 1/3 which will still make a large lot and have entrance off of Walnut Dr. which will require removal of only four trees.

A motion was made by S. Lindsay and seconded by D. Miller to table D. Meeker's plan until August 21st Board meeting so more study could be done and questions to attorney could be asked whether By Laws allowed such transactions. Motion carried.

Ron Morrow #2 was present to ask Board to rescind the penalty he was previously assessed on an unauthorized building permit. He explained how he repaired an unsafe deck off of his house and was not aware a permit was needed for this type of work.

After several questions and reports from Board members who had personally viewed this construction, a motion was made by R. Stansberry and seconded by S. Lindsay to revoke Ron Morrow's assessed penalty and to approve the reconstruction of his deck. Motion carried.

Patrolman's Report: W. Walker reported on B. Hohimer and youth worker, Tony P., tried to pull out the "No Wake" sign next to Lot #12 but had no luck.

There was also discussion on Jim Black's dog #36 still running loose.

A motion was made by R. Stansberry and seconded by R. Reardon to assess a \$50 fine for a second offense on uncontrollable dog. Motion carried.

A motion by S. Lindsay and W. Walker was made to approve the July Patrolman's Report as presented. Motion carried.

Minutes: A motion was made by S. Lindsay and R. Stansberry to approve the July 7, 1992 minutes as presented. Motion carried.

Bills: A motion was made by A. Tretter and seconded by R. Stansberry to approve for payment bills totaling \$2,664.98 which include two new bills; Clark Backhoe, \$150.00 and Macoupin Service, \$27.36. Motion carried.

A motion was made and seconded by S. Lindsay and R. Stansberry to add the Vice President's name to have authority to sign checks in absence of President or Treasurer. Motion carried.

There was discussion on what officers were bonded by insurance. As the secretary is only one bonded at this time, it was decided to

check on expense of adding the President, Vice President and Treasurer to a bond insurance policy and if reasonable amount, will add all officers to policy.

Aquatic Control & Recreation & Water Safety: W. Walker reported on taking two secchi disk water tests plus the other EPA monthly water test, he has received a EPA report paper which speaks good of the results. He also reported on heavy rain drainage has brought primrose weeds from Hays' farm area into lake, he will monitor problem.

Building & Construction: R. Stansberry made a report in Terri Charles' absence of the following permits: William Lamb #137, shed. Stansberry reported Lamb started this project earlier but wrote a letter stating he will finish project within a 30-day period by moving shed to back of house as permit states.

A motion was made by S. Lindsay and R. Stansberry to approve building permit submitted from Wm. Lamb #137 subject to it's completion within 30 days. Motion carried.

Farm Management: R. Stansberry reported on receiving income from wheat crop in amount of \$3,119.70.

Roads & Grounds: H. Sutton reported on investigating water drainage problem located between Lots #115, #116 & #117. After talking to owners of Lots #115, #116, DiDonato and Blankenship, they have agreed to rip rap area around lot and shed and use treated lumber to stop the washing water between their property and Lot #117, Clark who also approved the plan. Sutton also reported on stopping a speeder on lake from Lot #132 and will work on getting guard rail delivered.

Water Quality: R. Reardon reported that lake is full pool but still shows little algae growth; on the voluntary testing program, Sunset Lake was rated 36 out of 40 lakes which is still a good report and very complimentary to lake. Reardon asked if anything could be done with chemicals to clear weeds out of ponds. Board agreed to study problem.

Old Business: A. Tretter reported on mailing out 8 request for insurance package bids, received 2 quotes plus a few refusals and some only parcel quotes. He needs to analyze information before making any recommendations.

Pres. Gibbons asked for discussions or approval of proposed 1993 Budget.

A motion was made by S. Lindsay and seconded by R. Stansberry to accept the proposed 1993 Budget as presented and add to the agenda at the annual meeting for approval. Motion carried.

R. Reardon suggested presenting a pie chart showing receipts and expenses as an alternative to financial reports and stated he will work on this and present at a later date.

R. Stansberry asked everyone to still consider selling Sunset Lake property as an added income source. The matter was discussed and tabled for more study.

R. Reardon stated he had attended a meeting at the Nilwood Water Dept., he presented a plan for fill hydrants to be installed which will improve our fire protection, he will discuss plan plus expenses more thoroughly and report findings.

New Business: A motion was made by R. Stansberry and seconded by S. Lindsay to approve the proposed annual meeting agenda as presented. Motion carried.

W. Walker stated he would like to start a rip rapping project for northwest side of lake which is in dire need of repair.

After some discussion, a motion was made by W. Walker and seconded by S. Lindsay to add to annual meeting agenda for vote from members a \$10,000 rip rapping project to start on northwest lake shoreline. Motion carried.

B. Hohimer reported on an idea to have Macoupin Service supply an above-ground gas tank and new filters for present diesel tank instead of hauling gasoline back and forth in small cans in truck. Board agreed to have grounds committee study the plan and decide whether feasible or not.

Transfers: David Miller stated his transfer of property would not be until next month, so does not need approval at this time.

A motion was made by S. Lindsay and seconded by R. Stansberry to approve for transfer Lot 2A Block 21, Meter #145 Otto Whitler (James Whitler, Executor) to Joyce A. Payne subject to \$500 being held in escrow for approximately 50' of shoreline repair. Motion carried.

A motion was made by S. Lindsay and seconded by A. Tretter to approve for transfer Lot 11 Block 15, Meter #104 State Bank of Girard (John Zarr) to John Crocks and Shelley Crocks subject to \$500 being held in escrow for shoreline repair and grounds work. Motion carried.

A motion by R. Stansberry and D. Miller was made to adjourn the meeting. Motion carried.

Adjourned 10:00 p.m.

*Glenda M. Sutton*

Secretary

SUNSET LAKE ASSOCIATION

AGENDA

August 4, 1992

CALL TO ORDER

ROLL CALL

VISITORS' REMARKS

PATROLMAN'S REPORT

APPROVAL OF MINUTES OF July 7, 1992

APPROVAL OF BILLS

COMMITTEE REPORTS:

AQUATIC CONTROL & RECREATION & WATER SAFETY	-	WARD WALKER
BUILDING & CONSTRUCTION	-	TERRI CHARLES
FARM MANAGEMENT	-	RAY STANSBERRY
FINANCE	-	TERRI CHARLES
LEGAL & LITIGATION	-	FRANK GIBBONS & AL TRETTER
PUBLIC RELATIONS	-	SHARON LINDSAY
ROADS & GROUNDS	-	HENRY SUTTON
SANITATION, SHORELINE & BOAT DOCKS	-	DAVID MILLER
WATER QUALITY, SOIL CONSERVATION & RESTORATION	-	RAY REARDON
- Insurance Bids		
OLD BUSINESS- Approval of 1993 Budget		
- Mary Dopp #108 Extended Trellis		
NEW BUSINESS- Annual Meeting's Agenda		

TRANSFERS: Lot 7 Block 34 Meter #270A David K. Miller & Marsha J. Miller to Tom Cully & Leslie Cully

Lot 2A Block 21 Meter #145 Otto Whitler, James Whitler, Executor, to Joyce A. Payne

Lot 11 Block 15 Meter #104 State Bank of Girard(John Zarr) to John Crocks and Shelley Crocks

TO: Board Director

FROM: Secretary

Please plan to attend the regular meeting of Directors on Tuesday, August 4, 1992 at 7:30 p.m. at the lake office, 119 W. Madison, Girard.



SUNSET LAKE ASSOCIATION

SEPTEMBER 10, 1992

The regular Board of Directors meeting was held Thursday, September 10, 1992 at 119 W. Madison, Girard (Lake office). Pres. Frank Gibbons opened the meeting at 7:30 p.m. with the following Directors present: Frank Gibbons, Ray Reardon, Ward Walker, Mike DiDonato, Ray Stansberry, Sharon Lindsay, Al Tretter, Henry Sutton, and John Earley.

Visitors' Remarks: Jim Perry #26 asked a question concerning By Law Article II (Membership) Section 1 (d) Assessment of Members. He did not understand the reference to a \$30 per Class "A" Membership fee and did this change with 1993 Proposed Budget which had a \$35 per lot increase.

The Secretary explained the \$30 fee for each Class "A" membership is an amount initially set up at beginning of charter and does not change with annual budget increases.

Fred Gates #158 was present to report on shorelines that are appalling and need quick repairs besides a few that were passed at transfer time unfortunately unrepaired. He stated Board needs to be responsible and inform members of these repairs no matter who they are.

F. Gibbons stated a new committee has been assigned and inspections are scheduled.

R. Reardon also told of bi-annual inspections done with several Directors which review all committee areas and report their findings.

F. Gates hoped that all letters sent out informing members of general repairs were followed through until repairs were completed.

F. Gates also discussed the parking and storage of recreational vehicles at lake, area not designed for storage, after rule was changed to allow vehicle parking, 7 owners registered and 3 have annually renewed as rule states. He suggested establishing an area on Sunset Lake property for storing these vehicles to eliminate the unattractive appearance they now give the lake.

Board thought that idea could make many liability problems so we just need to adhere to the present rule to control situation.

F. Gates also discussed rules on fishing and skiing time, many violators are fisherman trying to fish during ski hours which can be a hazard. He suggested changing rules to state only ski time or fishing time, not both together. Board stated they will consider all suggestions.

Patrolman's Report: A motion was made by H. Sutton and seconded by S. Lindsay to approve August Patrolman's Report as presented. Motion carried.

Minutes: A motion was made by J. Earley and seconded by W. Walker to approve the August 21, 1992 organizational and regular minutes as presented. Motion carried.

Bills: A motion was made by S. Lindsay and seconded by W. Walker to approve for payment bills totaling \$965.55. Motion carried.

Aquatic Control, Recreation & Water Safety: W. Walker reported on not many violators and was glad it was the end of the season.

Building & Construction: M. DiDonato had nothing to report. Ray Stansberry explained Roy Denton's #264 request for an extension on permit to build a boat dock, the permit was issued in 1990 but due to

illness he was unable to complete project and was asking for a 1 year extension on that permit.

A motion was made by J. Earley and seconded by W. Walker to accept Roy Denton's request on his 1 year extension, this being marked on present permit and mailed to him for his knowledge. Motion carried.

Farm Management: J. Earley explained a chart he presented to Board showing alternatives on farming practices in future to maximize profits and increase revenue as high as possible for Association and exercise conservation measures in the process. Currently our tenant farmer, Harold Sanders, uses the 50/50 crop sharing method with the Association and conventional methods for tilling, which leaves the farm land highly vulnerable to several types of erosion. He has encouraged all other neighbor farmers to use a different type of tilling called no-till which does not leave land subject to erosion. He talked to Sanders about agreeing to use the better type of tilling method, the no-till method, for our farm land in 1993. Sanders would have to hire equipment to handle this type of farming and Sanders would not be doing any work himself. Earley proposed changing our current 50/50 crop sharing tenant farmer agreement to a custom farming agreement which entails the Association hiring work done and this would increase our revenue substantially besides improving our farming practices.

A motion was made by R. Stansberry and seconded by H. Sutton to approve the use of no-till custom framing method for 1993 and then review at end of year to decide if feasible to use in future. Motion carried.

Finance: S. Lindsay reported on giving everyone a up-to-date budget review to study and to report at next meeting what monies the chairperson is intending to spend this year on his budget or will they have extra money left over which can be use on other projects or expenses.

Legal & Litigation: F. Gibbons reported on current court cases as reported by Stuart Dobbs, our attorney. The Spence case is still on hold with hopes Judge will throw out; Wyatt case is still involved with paper work.

F. Gates suggested the annual meeting minutes should state that the voting on the By Law addition and project was passed unanimously with no decending votes.

A motion was made by H. Sutton and seconded by S. Lindsay to have annual meeting minutes show there were no decending votes on the motion to pass the By Law addition and project. Motion carried.

Roads & Grounds: H. Sutton reported on talking to David Werry #217 about an erosion and siltation problem around the area where he had a sanitation system installed, Werry was informed a silt fence or row of straw bales should be installed in this area until grass could be established to correct problem. Sutton stated soil, free of charge, could be transported from our North side silt pond if Werry paid for transportation charges. Guard rail has been picked up and ready to be installed, two bus turn-arounds are being installed, an old go-cart track near maintenance shed and Lot #166 is being obliterated by chisel plowing down and using land leveler to eliminate a low spot problem between properties. Sutton and Reardon explained installation and cost of bus turn-arounds on West Lake Dr. and North Lake Dr.

Change in bus route proposal has been presented to school board for acceptance, they will decide by 23rd of month.

Sanitation, Shoreline & Boat Docks: R. Stansberry reported on new system being installed at #136, Clarence McKinney, escrow money will be refunded; the shed has been moved and properly installed on Garnetta Lamb's lot #137; Roy Denton #264 has been informed to complete repairs on his shoreline; Stansberry will investigate Lots #20, #41 for shoreline repairs and Lot #37 for boat dock repairs; letter has already been mailed to R. Howington Lot #271 for shoreline repairs, and another letter will be mailed to inform Howington to remove an unlicensed truck parked on lot within a 30-day period to correct this violation or Association will have towed at Howington's expense.

Water Quality, Soil Conservation & Restoration: R. Reardon reported lake water very clear due to recent rains, results were good on secchi test.

Old Business: F. Gibbons read letter received from Stuart Dobbs, attorney, concerning D. Meeker's request to divide his lot. Attorney stated Board can make decision on lot division with a 2/3 vote of total Board number, establishing a new Class "A" membership requires only a majority vote, he recommended a survey be done marking area.

A motion was made by H. Sutton to approve lot division subject to certain stipulations are met, such as a survey done with a registered land surveyor, building codes met and provisions for an easement for driveway. Motion was dropped due to lack of second.

A straw vote was taken to see if all provisions are met according to attorney's recommendation and rules and regulations are met, would they agree for lot division. Four voted in favor and four voted present until more information can be given in better details.

H. Sutton stated he will inform D. Meeker that the Board basically understands how he wants lot divided, but they need more information on road access and how the right-a-way line is in relationship to his house. Also a survey will be needed on recommendation of attorney.

A. Tretter reported on insurance bids received, after study of these bids and the figures, his recommendation is to stay with current agent which will best serve the Association.

New Business: A motion was made by R. Stansberry and seconded by J. Earley to have an annual weiner roast west of maintenance shed on October 3, 1992 starting at 4:00 p.m. Motion carried.

After some discussion, a motion was made by S. Lindsay and A. Tretter to have Association supply the place for a weiner roast, a fire, condiments, bales of straw and porta-potties and each member can bring own eats and beverages. Motion carried.

Board discussed the storage of recreational vehicles on lake. It was agreed all members should adhere to current rule of a yearly permit and notification will be included in current mailing being sent out next week.

F. Gibbons appointed H. Sutton and Mike DiDonato to serve on a committee to approve these R.V. permits.

A motion was made by R. Stansberry and seconded by M. DiDonato to table the suggestion on changing the fishing and skiing times subject to further study. Motion carried.

F. Gibbons reported on a culvert problem channeling water mainly on neighbors property #112A but also on his Lot #113. He is recommending dividing the cost of this project to correct problem by thirds, 1/3 to Gibbons, 1/3 to E. Scott and 1/3 to Sunset Lake Association.

A motion was made by M. DiDonato and seconded by S. Lindsay to approve recommendation of dividing cost of project with neighboring members and Association. Motion carried.

A motion was made by H. Sutton and seconded by S. Lindsay to have an erosion control plan filed with building and sanitation permits showing plans for a silt fence or barrier of some type before permit can be approved. If plan is not followed through, a fine of \$20 a day will be issued from the date of infraction and continued until infraction is corrected and approved by Building Committee. Motion carried.

Transfers: A motion was made by S. Lindsay and seconded by J. Earley to approve for transfer Lot 7 Block 34 Meter #270A David K. Miller and Marsha J. Miller to Tom Cully and Leslie Cully subject to \$800 escrow be held for shoreline repairs and all proper paper work in order. Motion carried with 7 yes and 1 no.

A motion was made by S. Lindsay and seconded by A. Tretter to accept for transfer Lot 13 Block 26, Meter #207 Norman P. Jones & Willa Jean Jones to Roger & Judy Jennings. Motion carried.

A motion was made by A. Tretter and W. Walker to accept for transfer Lot 2 Block 15, Meter #103 Ruth Seifert to Brad A. Cox subject to \$400 be held in escrow for shoreline repairs, \$25 held for diving board removal and all proper paper work in order. Motion carried.

A motion by A. Tretter and J. Earley was made to adjourn meeting. Motion carried.

Adjourned 10:40 p.m.

*Glenda M. Sutton*

Secretary

SUNSET LAKE ASSOCIATION

AGENDA

September 10, 1992

CALL TO ORDER

ROLL CALL

VISITORS' REMARKS

PATROLMAN'S REPORT

APPROVAL OF MINUTES OF August 21, 1992

APPROVAL OF BILLS

COMMITTEE REPORTS:

AQUATIC CONTROL & RECREATION & WATER SAFETY - WARD WALKER

BUILDING & CONSTRUCTION - MIKE DIDONATO

FARM MANAGEMENT - JOHN EARLEY

FINANCE - SHARON LINDSAY

LEGAL & LITIGATION - FRANK GIBBONS, AL TRETTER

PUBLIC RELATIONS - SHARON LINDSAY

ROADS & GROUNDS - HENRY SUTTON

SANITATION, SHORELINE & BOAT DOCKS - RAY STANSBERRY

WATER QUALITY, SOIL CONSERVATION & RESTORATION - RAY REARDON

OLD BUSINESS : Dennis Meeker's lot division plan

NEW BUSINESS : Annual Weiner Roast

TRANSFERS: Lot 7 Block 34 Meter #270A David K. Miller & Marsha  
J. Miller to Tom Cully & Leslie Cully

Lot 13 Block 26 Meter #207 Norman P. Jones & Willa  
Jean Jones to Roger & Judy Jennings

Lot 2 Block 15 Meter #103 Ruth Seifert to Brad A. Cox

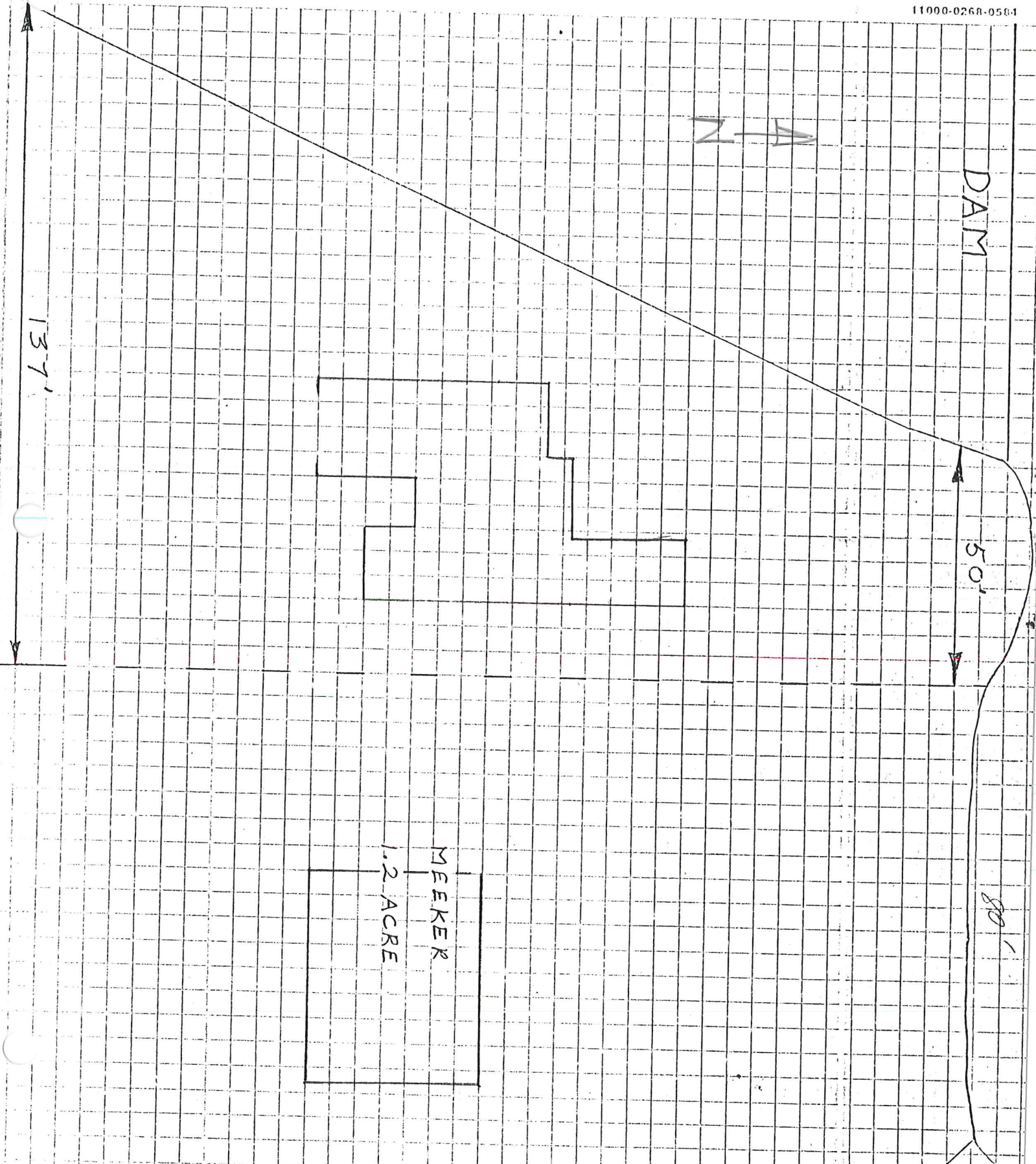

NORTH OTTER TWP.

7-D

CH. 12

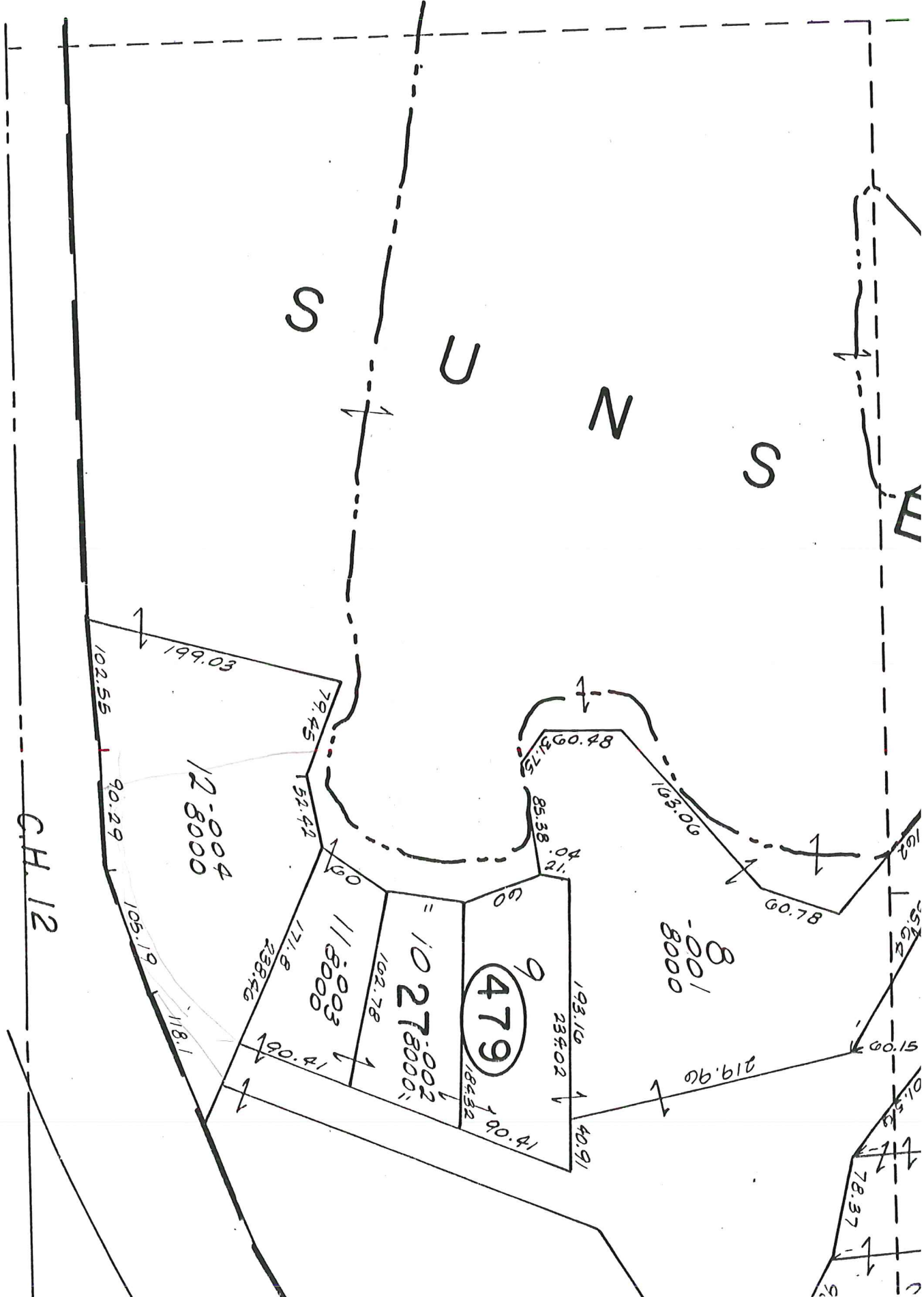

SUNSET LAKE ASSOCIATION

CASH POSITION

AUGUST 31, 1992

Cash on Hand (Petty Cash)		\$	100.00
State Bank of Girard			
Checking	\$	892.28	
Money Market Fund - General		20,927.99	
- Interest		<u>69.83</u>	
			<u>\$ 21,890.10</u>
Total General Revenue			\$ 21,990.10
State Bank of Girard			
Money Market Fund - Special (Dam)	\$	14,781.12	
- Interest		<u>42.52</u>	
			<u>\$ 14,823.64</u>
Total Revenue			<u>\$ 36,813.74</u>
State Bank of Girard - (escrow)			<u>\$ 9,300.00</u>

Monthly Receipts:

Assessments	- General	\$	259.85
	- Island		35.00
Boat Permits			49.00
Building Permits			25.00
Fines & Penalties			44.00
Transfer Fees			600.00
Earned by Maintenance Man			289.25
Misc. Income	- Wheat		52.36
	- Chlorine Tablets		<u>16.00</u>
Total			<u>\$ 1,370.46</u>



SUNSET LAKE ASSOCIATION

AGENDA

October 6, 1992

CALL TO ORDER

ROLL CALL

VISITORS' REMARKS

PATROLMAN'S REPORT

APPROVAL OF MINUTES OF September 10, 1992

APPROVAL OF BILLS

COMMITTEE REPORTS:

- AQUATIC CONTROL & RECREATION & WATER SAFETY - WARD WALKER
- BUILDING & CONSTRUCTION - MIKE DIDONATO
- FARM MANAGEMENT - JOHN EARLEY
- FINANCE - SHARON LINDSAY
- LEGAL & LITIGATION - FRANK GIBBONS, AL TRETTER
- PUBLIC RELATIONS - SHARON LINDSAY
- ROADS & GROUNDS - HENRY SUTTON
- SANITATION, SHORELINE & BOAT DOCKS - RAY STANSBERRY
- WATER QUALITY, SOIL CONSERVATION & RESTORATION - RAY REARDON

OLD BUSINESS - Boat stickers

NEW BUSINESS - *computation*

TRANSFERS:

TO: Board Directors

FROM: Secretary

Please plan to attend the Directors meeting Tuesday, October 6, 1992 at lake office, 119 W. Madison, Girard starting at 7:30 p.m.

SUNSET LAKE ASSOCIATION  
 CASH POSITION  
 SEPTEMBER 30, 1992

Cash on Hand (Petty Cash)		\$ 100.00
State Bank of Girard		
Checking	\$ .01	
Money Market Fund - General	16,133.99	
- Interest	<u>58.85</u>	
		\$ <u>16,192.85</u>
Total General Revenue		\$ 16,292.85
State Bank of Girard		
Money Market Fund - Special (Dam)	\$ 15,183.64	
- Interest	<u>43.12</u>	
		\$ 15,226.76
Money Market Fund - Equipment Reserve		<u>\$ 2,500.00</u>
Total Revenue		<u>\$ 34,019.61</u>
State Bank of Girard - (escrow)		<u>\$ 4,300.00</u>

Monthly Receipts:

Assessments - General	\$ -0-	
- Island	-0-	
Boat Permits	16.00	
Building Permits	60.00	
Fines & Penalties	-0-	
Transfer Fees	300.00	
Earned by Maintenance Man	125.00	
Misc. Income - Culvert project division	118.17	
- Chlorine Tablets	<u>16.00</u>	
Total		<u>\$ 635.17</u>

SUNSET LAKE ASSOCIATION  
OCTOBER 6, 1992

Bills to be approved for payment:

Rural Electric		\$ 164.02
GTE- North	- 627-3232 - \$42.29	
	- 627-3339 - <u>35.39</u>	77.68
Mary Robertson	- 3 bond refunds & interest	360.00
Illinois Department of Revenue	- IL. W/H	153.63
State Bank of Girard	- FICA & FED. W/H Taxes	436.79
Illinois Director of Employment Security	- unemployment	13.92
John G. Miller & Sons	- culvert project #113	354.50
ADGPTV Water Commission	- utilites	75.00
State Bank of Girard	- petty cash	44.95
Glenda Sutton	- net salary	365.51
William Hohimer	- net salary	<u>1,072.78</u>
	Sub-Total	\$ 3,118.78
Crown Trucking Inc.	- rock hauling	82.69
Nokomis Quarry Co.	- rock - 22 ton	88.20
Mike Neff	- 47 straw bales	<u>77.55</u>
	Total	<u>\$ 3,367.22</u>

PATROLMAN'S REPORT  
SEPTEMBER, 1992

- Sept. 1 Dog catcher picked up Jim Black's dog, mowed all day.  
2 Mowed North Lake Dr.  
3 Called telephone co. to locate cable for installation of guard rail, called water commission for water line location.  
4 Took tractor and truck to move big cotton wood tree at Lot #3 Murducks, charged \$25.00.  
6 Labor Day weekend.  
7 Patrolled lake, water test tomorrow.  
8 Fixed road at Mae Ess, dug out bump, cut ditch bank and filled with black patch - this is old patch, I don't think it will hold. John Cheeks stopped, said he had sworn out an arrest warrent on Mary Dopp #108 for pulling a gun on him. Ward was there also.  
9 Cleaned up where Terry Clark had rock for sand filters. Ordered pipe for Lots #112A & #113 so Frank G. can catch run off of road, sharpened mower blades, cut grass & weeds on black top near North Lake sign on west side.  
10 Ordered out house for wiener roast, mowed the Island and 2 hrs. tractor work on Lot #251.  
11 Finished Island, got grass seed and reseeded Island.  
14 Cleaned burn piles.  
15 Shocked lake with Illinois Conservation Dept., lots of nice red ear, 1 flat head catfish was 49½" long and over 50#s.  
16 Lot #115 & #116 Vine, moved rip rap pile with tractor for 1½ hours for Mike DiDonato, did 15 minute tractor work at Lot #167, Ray Fickas, trimmed trees at dry pond on Circle Dr. across from Lot #10, the pipe that goes under road is rusted out, has big wash out, needs to be fixed before pond is cleaned, also water line goes through the pond, if pipe is fixed, there wouldn't be a need to clean pond.  
17 Burnt brush that was cut yesterday, got Pat Wilkin 16 bales of straw from Mike Neff to stop run off. Frank G. pipe will be here tomorrow.  
18 Cut fire wood for wiener roast, burnt brush.  
21 At Lot #115 Mike DiDonato, delivered green mesh, 750 ft. at 21¢ = \$157.50, 6 bales of straw at \$2.00 each = \$12.00, trimmed low limbs.  
22 Talked to Gary Hays, dry pond has a hole in it. He said after he gets crops out he would try to fix. More clean up in parks.  
23 REA needed to know about limbs in wires, went around lake with them, serviced tractor to start mowing.

- 24 Sharpened blades, cleaned up old lumber and trash around shed and burnt.
- 25 Just a lot of small things to pick up and to start mowing.
- 28 Started mowing west of shed.
- 29 Picked up wiener roast wood and got it ready then mowed.
- 30 Mowed and got more wood.
- Oct 1 Got outhouse and checked on straw and wagons, mowed.
- 2 Mowed North side, moved 16 ton of sand for Ray Fickas and some rock for 1½ hours.
- 3 Got wagons and straw bales for wiener roast from Mike Neff.

Bill Hohimer

SUNSET LAKE ASSOCIATION

NOVEMBER 3, 1992

The regular Board of Directors meeting was held Tuesday, November 3, 1992 at 119 W. Madison, Girard, the lake office. Pres. Frank Gibbons called the meeting to order at 7:30 p.m. with the following Directors present: Frank Gibbons, Ray Stansberry, Ray Reardon, Ward Walker, Sharon Lindsay, Mike DiDonato, Henry Sutton and John Earley.

Visitor's Remarks: Robert Fish #110 was present to ask permission to reside in his camper trailer parked on his lot until he could finish construction on his house as he is from Michigan. This would require an extension of his present two-week camping permit for another two weeks.

A motion was made by J. Earley and seconded by R. Stansberry to grant permission for an extended two-week camper trailer permit to Robert Fish #110. Motion carried.

Patrolman's Report: A motion was made by R. Stansberry and seconded by R. Reardon to approve the October Patrolman's Report as presented. Motion carried.

A motion was made by H. Sutton and seconded by J. Earley to appropriate \$600 toward the purchase and mounting of four new tires for pick-up truck. Motion carried.

A motion was made by J. Earley and seconded by R. Stansberry to approve the purchase of a heater for maintenance shed. Motion carried.

An amended motion was made and seconded by M. DiDonato and R. Stansberry to allocate \$1,000 toward this purchase plus appoint a committee to handle the purchase. Motion carried.

F. Gibbons appointed J. Earley and W. Walker to this committee.  
Minutes: A motion was made by S. Lindsay and seconded by R. Stansberry to approve the October 6, 1992 minutes as presented. Motion carried.

Bills: A motion was made by S. Lindsay and seconded by H. Sutton to approve for payment the bills totaling \$2,442.17. Motion carried.

Aquatic Control & Recreation & Water Safety: W. Walker reported placing ad in local paper asking for estimates to rip rap west shoreline. He hasn't received many calls yet but they have to December 1, 1992. Walker stated Wiseman offered free concrete from Virden, Wiseman will load if we haul away; secchi test and water samples were taken, possibly will be last one taken as patrol boat is being taken out of water, water test showed great clarity and visability of water. Walker also asked for help in finding a trapper, one previously hired does not have extra time.

A motion was made by R. Stansberry and seconded by R. Reardon to place an ad in local paper asking for any interested trapper to trap Sunset Lake area this season. Motion carried.

Building & Construction: M. DiDonato reported on checking if Floyd Volz #232 & #233 had a building permit and was found to be current and on file. DiDonato reported on the following permits: John Crocks #104, room addition; Robert Fish #110, garage. He also reported on a permit from Bruce Weller #247 for a playhouse approximately size of a shed.

After examining plans, a motion was made by R. Stansberry and seconded by S. Lindsay to approve the building permit and \$25 fee received from Bruce Weller #247 for a playhouse. Motion carried.

DiDonato asked Board's opinion on a permit received from Lester Spence #262 for a boat dock and a boat house. Spence will be adding to boat dock but will only be replacing roof on boat house, what fee should he be charged? Board agreed to only charge for the addition to dock. He also reported on more permits: Robert Boyle & Anthony Zummo #198, room addition; Mike Higginson #143, room addition and Glenn Ford #156, shed. A permit from Ronald Weller #241 was to replace a shed, no fee was charged.

Farm Management: J. Earley reported on talking to Harold Sanders about releasing Sunset Lake's agreement with him as tenant farmer, he found no problems with this. Earley stated he will be ordering next year's bean seed this year to get a discount.

Finance: S. Lindsay stated a year-to-date budget will be prepared for next meeting to show amounts available for the remaining of this year.

Legal & Litigation: F. Gibbons reported on the current court cases: the Wyatt case is arranging for depositions; the Spence case could possibly be dismissed by the Judge before Thanksgiving.

Roads & Grounds: H. Sutton reported waiting on Cablevision to raise a cable wire before a bus turn-around can be worked on; working on a stump removal problem; need help to install guard rail; have not heard from Dennis Meeker on decision to divide lot. Sutton also read letter received from Carole & Robert Foster #194 asking permission to park their pontoon boat on Sunset Lake property across from their property. Board agreed to this request.

The erosion problem at David Werry #217 was discussed, he has not corrected this problem as he stated he would earlier.

A motion was made by R. Stansberry and seconded by H. Sutton to have required amount of straw bales spread on Lot #217 to correct and stop erosion on this bank and charge D. Werry for expenses. Motion carried.

Sanitation, Shoreline & Boat Docks: R. Stansberry reported on results of letters sent to members concerning repairs requested at their property: everyone on list are adhering to request except Carl Wilson #196 and Clara Shewmaker #246A, therefore letters will be sent to them asking for their plans to correct these violations or Board will have violations corrected and charge members for incurring expenses. Stansberry also reported on installing more black buckets in water to enhance crappie habitat.

Old Business: Secretary explained ADGPTV Water Commission is considering purchasing computers for office and asked if Sunset Lake would be interested in paying an agreed monetary amount which then we could purchase our own software programs and use the computer and printing equipment.

After some discussion, a motion was made by R. Stansberry and seconded by M. DiDonato to table until next meeting for further study. Motion carried.

Transfer: A motion was made by S. Lindsay and seconded by R. Reardon to approve transfer of Lot 2 Block 33, Meter #240 Walter Clark and

SUNSET LAKE ASSOCIATION

( 3 )

NOVEMBER 3, 1992

Henrietta Clark to Dan Scharfenberg and Elaine Scharfenberg.  
Motion carried.

A motion was made by R. Stansberry and seconded by J. Earley  
to adjourn meeting. Motion carried.

Adjourn 9:05 p.m.

*Glenda M. Sutton*

Secretary



**Section 18 - Picnicking and Camping**

(d) (Storage of Trailers, Recreational Vehicles or Motor Homes) No trailer, recreational vehicle, or motor home may be stored on a lot except by special permission of the Board of Directors on an annual basis.

---

**SUGGESTED REVISION TO THIS RULE BY COMMITTEE**

(d) Storage of camping trailers, recreational vehicles or motor homes. Each member is permitted to have a total of one (1) either camping trailer, recreational vehicle, or motor home stored on their property by obtaining an annual permit from the Association. All units must be licensed and registered in the members name and cannot be stored on either another members property or a vacant lot. An annual permit will cost \$5 and a bumper sticker will be issued which must be properly displayed at all times on the stored vehicle. The first offense to this rule will be a written warning and if the situation is not corrected within 7 days the second offense will be a \$25 fine.

Committee: Hank Sutton  
Mike DiDonato

REVISED BUDGET  
 \*\*\*\*\*  
 SUNSET LAKE ASSOCIATION  
 PROPOSED 1993 BUDGET

REVENUE:

General Assessments	\$35.00 increase per lot	\$ 49,750.00
Building Permits		600.00
Fines & Penalties		300.00
Farm Income		2,500.00
Interest		1,200.00
Transfer & Lease Fees		5,000.00
Boat Permits (Year 1 of 2 yr. period)		5,000.00
CableVision		1,300.00
Earned by Maintenance Man		500.00
Other Receipts		400.00
		<hr/>
	Total Revenue	<u>\$ 66,550.00</u>

EXPENDITURES:

Patrol & Maintenance Man's Salary		\$ 16,565.00
Secretary's Salary		5,907.50
Legal & Accounting Fees		4,000.00
Office Rent		900.00
Postage, Printing & Office Expense		2,000.00
Maintenance: Lake		3,500.00
Roads		8,000.00
* Grounds		* 1,100.00
* Shoreline		* 1,500.00
Equipment		1,800.00
Conservation & Watershed		2,000.00
Gas & Oil		1,800.00
Maintenance Expense & Supplies		200.50
Farm Expense		1,000.00
Fish Stocking		1,000.00
Utilities		2,500.00
Insurance		5,500.00
Employment Taxes		1,850.00
Property Taxes		2,427.00
Miscellaneous, Interest, Mileage & Etc.		500.00
Equipment Reserve		2,500.00
		<hr/>
	Total Expenditures	<u>\$ 66,550.00</u>

\* Indicates changes per minutes 10-6-92

SUNSET LAKE ASSOCIATION

AGENDA

November 3, 1992

CALL TO ORDER

ROLL CALL

VISITORS' REMARKS

PATROLMAN'S REPORT

APPROVAL OF MINUTES OF October 6, 1992

APPROVAL OF BILLS

COMMITTEE REPORTS:

AQUATIC CONTROL & RECREATION & WATER SAFETY - WARD WALKER

BUILDING & CONSTRUCTION - MIKE DIDONATO

FARM MANAGEMENT - JOHN EARLEY

FINANCE - SHARON LINDSAY

LEGAL & LITIGATION - FRANK GIBBONS, AL TRETTER

PUBLIC RELATIONS - SHARON LINDSAY

ROADS & GROUNDS - HENRY SUTTON

SANITATION, SHORELINE & BOAT DOCKS - RAY STANSBERRY

WATER QUALITY, SOIL CONSERVATION & RESTORATION - RAY REARDON

OLD BUSINESS - Computers

NEW BUSINESS

TRANSFERS: Lot 2 Block 33, Meter #240 Walter & Henrietta Clark  
to Dan & Elaine Scharfenberg

TO: Board Directors

FROM: Secretary

Please plan to attend the regular Directors meeting Tuesday,  
November 3, 1992 at 119 W. Madison, lake office, starting at 7:30 p.m.

SUNSET LAKE ASSOCIATION  
NOVEMBER 3, 1992

Bills to be approved for payment:

Rural Electric Conv.		\$ 164.02
Nilwood Water System		7.75
Gold Nugget	- statement & permits	119.10
GTE-North	- 627-3232 - \$42.61	
	- 627-3339 - <u>35.19</u>	77.80
State Bank of Girard	- Fed W/H & FICA Taxes	436.77
Girard Hardware	- spray paint	9.54
Konneker-Brown, Inc.	- chainsaw chains & bar oil	50.47
ADGPTV Water Commission	- utilities	75.00
Glenda Sutton	- net salary	365.51
William Hohimer	- net salary	1,072.78
State Bank of Girard	- petty cash	15.43
Peoria Addressing Service	- addressographs	<u>9.00</u>
	Sub-Total	\$ 2,403.17
Gold Nugget Publ.	- ad for shoreline repairs	<u>40.00</u>
	Total	\$ 2,443.17

SUNSET LAKE ASSOCIATION  
CASH POSITION  
OCTOBER 30, 1992

Cash on Hand (petty Cash)		\$ 100.00
State Bank of Girard		
Checking	\$ 200.82	
Money Market Fund - General	13,941.51	
- Interest	<u>64.09</u>	
		<u>\$ 14,206.42</u>
Total General Revenue		\$ 14,306.42
State Bank of Girard		
Money Market Fund - Special (Dam)	\$ 15,226.76	
- Interest	<u>54.75</u>	
		\$ 15,281.51
Money Market Fund - Equipment Reserve		<u>\$ 2,500.00</u>
Total Revenue		<u>\$ 32,087.93</u>
State Bank of Girard - (escrow)		<u>\$ 200.00</u>

Monthly Receipts:

Assessments	-	General	\$ -0-	
	-	Island	-0-	
Boat Permits			-0-	
Building Permits			-0-	
Fines & Penalties			-0-	
Transfer Fees			500.00	
Earned by Maintenance Man			376.50	
Misc. Income	-	Culvert project div.	118.17	
	-	Chlorine tablets	16.00	
	-	RV Vehicle Fee-1993	5.00	
	-	Straw bales	<u>68.00</u>	
Total				<u>\$ 1,083.67</u>

PATROLMAN'S REPORT

OCTOBER, 1992

- Oct. 1 Got Portapotties and checked on straw and wagons for wiener roast then mowed.
- 2 Mowed North side, moved 16 tons of sand for Ray Fickas for 1½ hours.
- 3 Got wagons and straw bales for wiener roast, lit fire.
- 4 Took wagon home.
- 5 Picked up straw, sold some, rest is at shed, burnt brush, mowed dam, took water test.
- 6 Finished mowing, cleaned mower and put up.
- 7 Cleaned up burn piles on North Lake Dr. and West Lake Dr.
- 8 Trimmed and burnt piles.
- 9 Took day off.
- 12 Answered calls on letters sent by lake board on boat docks and rip rap.
- 13 More clean up before leaves.
- 14 Staked out bus turn around with Hank, started to clean brush.
- 15 Had saw worked on, got chain oil and chains, worked on brush.
- 16 All small brush cut, piled and burnt.
- 19 Cleaned more brush, also cut limbs over roads.
- 20 Burnt brush, got leaf blower out and started in ditch on West Lake Dr.
- 21 Water test taken, rock delivered to Fred Gates, talked to Joyce Hawley Lot #271 on rip rap, will take load on Sat.
- 22 Burnt brush, help get boat out of water at Mick Stankoven, charged \$10.00, also hurt back on boat motor.
- 23 Loaded rip rap for Mrs. Hawley Lot #271, burnt leaves on north side.
- 24 Sat. took load of concrete to Lot #271, Charged \$40.00.
- 26-30 Worked on leaves all week, all leaves in all parks and roads are done - no leaves on North side. Winter is coming - need tires on truck and heat in shed.

Bill Hohimer

SUNSET LAKE ASSOCIATION

OCTOBER 6, 1992

A regular Board of Directors meeting was held Tuesday, October 6, 1992 at 119 W. Madison, Girard, lake office. Pres. Frank Gibbons called the meeting to order at 7:30 p.m. with the following Directors present: Henry Sutton, Ray Reardon, Ray Stansberry, Mike DiDonato, Frank Gibbons, Sharon Lindsay, Ward Walker, John Earley and Al Tretter.

Patrolman's Report: A motion was made by R. Reardon and seconded by A. Tretter to approve the September Patrolman's Report as presented. Motion carried.

Minutes: A motion was made by S. Lindsay and seconded by A. Tretter to approve the September 10, 1992 minutes as presented. Motion carried.

Bills: A motion was made by S. Lindsay and seconded by R. Reardon to approve for payment bills totaling \$3,367.22. Motion carried.

Aquatic Control & Recreation & Water Safety: W. Walker reported members contacted IL. Conservation Department about shocking lake which they did last week with good results. The Dept. was impressed how well the fish looked, healthy and fat, several large fish were inspected including a 50 lb. catfish near dam and the best size red ear they've seen. A written report from Dept. explaining weight, condition & etc. will be sent in early part of 1993. Walker stated more water testing was done, EPA test and secchi test with results showing greater clarity; not much patrolling, traffic slow.

Building & Construction: M. DiDonato reported on three building permits: Paul Thomas #17, garage; Clarence Davis #183; John Crocks #104, addition.

Lindsay reported on a request from Bruce Weller #247 to build a tree house on his property.

A motion was made by R. Stansberry and seconded by W. Walker to approve the construction of a tree house on Bruce Weller #247 property subject to presenting a plan to building committee with a \$5 building permit fee and final approval from Board. Motion carried.

Finance: S. Lindsay reminded Board to submit any end of the year budget plans.

R. Stansberry requested a \$1,500 shoreline maintenance budget for 1993 which would be separate from grounds.

A motion was made by S. Lindsay and seconded by H. Sutton to change the 1993 grounds budget from \$2,600 to \$1,100 and put the \$1,500 difference to form the Shoreline Maintenance budget. Motion carried.

Public Relations: S. Lindsay reported on a successful wiener roast Saturday with good weather; will put a picture of 50 lb catfish registered when shocking lake in local paper and when shocking information report is available, will also put in paper.

Roads & Grounds: H. Sutton reported on waiting for information from school before he can start on bus turn-arounds, no final commitments have been received from school board, they are still working on scheduling; Sutton will install guard rails and turn arounds even if school does not agree at this time to rescheduling.

Sanitation, Shoreline & Boat Docks: R. Stansberry reported on approval of Henry Smith #130 new sanitation system and escrow will be released;

OCTOBER 6, 1992

Howington & Hawley #271 has contacted Reardon and stated truck will be licensed and they are working on shoreline repairs slowly; Stansberry and Hohimer inspected shorelines and boat docks and gave list of violators on repairs asking letters be sent to notify members of these violations. He also talked to David Werry #217 about property erosion, Werry wants to rip rap area but Stansberry disapproved of this solution, he recommended putting down grass seed and straw bales to hold seed for best erosion control. Hohimer reported Werry has hired a landscaping firm to solve problem. Stansberry reported on installing a new type of device to help the crappie habitat, he has installed one near his shoreline and plans on placing two more in other areas in future.

Stansberry stated Bruce Weller #247 requested storing dirt removed from dredging out cove on Sunset Lake property which is across the street from his property.

Board agreed committee should look at area first but will need a dry dirt berm to control any drainage from dirt that could spread to roads & etc.

Stansberry said Don Burgess #229 wants to install a 10" tile in ditch and hook to present 10" tile to eliminate ditch which would be a partial cost to Sunset Lake. Stansberry also requested all extra dirt on projects not be removed but stored on Sunset Lake property for reuse on other projects.

Water Quality, Soil Conservation & Restoration: R. Reardon reported on good results on water samples tests, water very clear.

Old Business: Gibbons asked Board's opinion on changing or keeping same boat stickers.

A motion was made by R. Stansberry and seconded by W. Walker to keep same format of boat stickers for years 1993-1994. Motion carried.

H. Sutton reported on talking to Dennis Meeker about the division of his lot, discussed different options and will keep in contact.

H. Sutton asked what plans have been done on rip rapping Sunset Lake shoreline.

W. Walker suggested advertising in local paper for interested parties to contact Sunset Lake and give estimated cost to rip rap area, this will get program started for possible completion of work next year.

R. Reardon showed examples of different types of erosion control material, the company that supplies these samples is interested in showing its capabilities. W. Walker stated he will investigate.

Mike DiDonato stated he and H. Sutton put together a revised rule and regulation on Storage of Recreational Vehicles trying to answer issues such as: control of vehicles, storage area, limiting units and eliminating possibility of eye sore. He read a suggested revision to Section 18 (d) to Board which states: limiting members to only one unit stored, \$5 permit with sticker displayed on vehicle necessary and if in violation, a written warning first, then a \$25 fine issued if still in violation after 7 days.

A motion made by R. Stansberry to table decision until next meeting was dropped due to lack of a second.

A motion was made by R. Stansberry and seconded by M. DiDonato to accept the rule and regulation revision of Section 18 (d) as read



subject to changing the wording from "or a vacant lot." to "or Sunset Lake property." Motion carried. (copy attached)

New Business: Secretary informed the Board the ADGPTV Water Commission is considering purchasing a computer for their office and is asking Sunset Lake if they might be interested in an agreement to use the computer for their own business. Board asked to be kept informed.

A motion was made by R. Stansberry and seconded by R. Reardon to adjourn the meeting. Motion carried.

Adjourned 9:30 p.m.



Secretary

SUNSET LAKE ASSOCIATION

DECEMBER 1, 1992

The regular Board of Directors meeting was held Tuesday, December 1, 1992 at 119 W. Madison, Girard (lake office). Pres. Frank Gibbons called the meeting to order at 7:30 p.m. with the following Directors present: Henry Sutton, Ray Stansberry, Ray Reardon, Ward Walker, Al Tretter, Sharon Lindsay, Mike DiDonato and Frank Gibbons.

Visitor's Remarks: James Black #36, #36A was present to discuss the fines and expenses assessed to him because of problems with a loose dog. He explained the dog was not his, but was trying to find dog's owner, so even though dog was picked up by County dog catcher twice, he returned dog to his house to return to owner if he was found. He therefore did not understand why he was charged for expenses and penalized for violations on a dog that wasn't his.

The Board reviewed the fines, \$75 was assessed as a fine and \$30.50 was an expense charged by the Macoupin County Dog Catcher for two dog pick ups.

A motion was made by R. Stansberry and seconded by S. Lindsay to lower the fines and charges assess to James Black to \$50 which will cover expenses and maintenance man's time. Motion carried.

Dennis Meeker Lot #215 was present to discuss the division of his lot into two lots. He showed plans for this division, the only problem was where second lot's driveway would be constructed.

F. Gibbons appointed R. Stansberry, H. Sutton and S. Lindsay as a committee to meet with Meeker and view property and give proposal at next meeting.

Roger & Judy Jennings #205, #206 were present with Florence Jennings #207 to discuss the possibility of Florence J. purchasing adjoining Sunset Lake property in order for her to have enough land to build a house, she would agree to all of this lake lot or a partial section.

F. Gibbons appointed H. Sutton and R. Stansberry to a committee to meet with Jennings and look at property in discussion this Saturday, but also ask all available Board members to view property for their ideas.

Patrolman's Report: A motion was made and seconded by M. DiDonato and A. Tretter to approve the November Patrolman's Report as presented. Motion carried.

Minutes: A motion was made and seconded by R. Stansberry and A. Tretter to approve the November 3, 1992 minutes as presented. Motion carried.

Bills: A motion was made and seconded by S. Lindsay and A. Tretter to approve for payment the bills which total \$6,533.35, this includes a \$100 Christman Bonus each for the two employees. Motion carried.

Aquatic Control, Recreation & Water Safety: W. Walker reported on an incident involving one of Terri Charles' dogs Lot #7 being caught and killed in a trappers set trap on Sunset Lake property as the dog was not contained to it's own yard. Traps are only set on Sunset Lake property or on members property only with special permission. Walker discussed an estimate he received from John Miller

& Sons for rip rapping the west shoreline on Sunset Lake property. Miller estimated a cost of \$12,000 for hauling and laying 500 tons of 4X6 rip rapping, lower price if rock can be hauled earlier than job, recommended starting job in June or July, 1993. Board was given a copy of estimate to study before decision is made.

Finance: S. Lindsay reviewed the year-to-date budget stating it needs to be rechecked at January meeting when all end of year bills are paid.

Roads & Grounds: H. Sutton reported that rain has slowed process on completing the bus turn-arounds, he is half finished on larger turn-around, he estimated an amount of \$1,400 needed for rock to complete project.

Sanitation, Shoreline & Boat Docks: R. Stansberry reported on only one member left that has not completed repairs on his property that are in violation; a problem with completing a rip rapping job at Dave Miller #270A, new owner, Tom Cully, would not let hired contractor finish his job. Board agreed on continuing to hold escrow money until seller and buyer can solve their problem.

Old Business: Secretary reported Water Commission has not had their monthly meeting yet to decide on purchasing computers, therefore a motion was made and seconded by R. Stansberry and W. Walker to table discussion until later date. Motion carried.

New Business: Board decided to hold January's meeting on regular date and plan a social dinner for Board Directors and spouses on a different date.

R. Reardon reported on being concerned for Bruce Weller #247 dog who has a habit of chasing cars on West Lake Dr.

Board decided to send letter to Bruce Weller and ask for his cooperation in controlling his dog.

Transfers: A motion was made by S. Lindsay and seconded by W. Walker to approve for transfer Lots 4 & 5 Block 12, Meters #87, #87A Phil Collins and Brenda Collins to Marshall Bell and Bonnie Bell. Motion carried.

A motion was made by S. Lindsay and seconded by W. Walker to approve for transfer Lots 3 & 5 Block 6, Meters #36 & #36A James Black and Diane Black to John Gordon and Sandy Gordon subject to all accounts being paid in full. Motion carried.

A motion was made by S. Lindsay and seconded by R. Stansberry to approve for transfer Lots 3 & 1 Block 4, Meters #20 & #20A Francis S. Edwards & Florence M. Edwards to Gerald Knudson & Judith Knudson subject to \$1,500 escrow being held for repairs to shoreline. Motion carried.

A motion was made by R. Stansberry and seconded by S. Lindsay to approve for transfer Part of Lot 7 Block 28, Meter #223 Edna Fisher to Louis Long and Sue Long subject to \$4,000 being held in escrow for installation of sanitation system. Motion carried.

Meeting adjourned 9:45 P.M.

*Glenda M. Sutton*

Secretary

SUNSET LAKE ASSOCIATION

AGENDA

December 1, 1992

CALL TO ORDER

ROLL CALL

VISITORS' REMARKS

PATROLMAN'S REPORT

APPROVAL OF MINUTES OF November 3, 1992

APPROVAL OF BILLS

COMMITTEE REPORTS:

AQUATIC CONTROL & RECREATION & WATER SAFETY - WARD WALKER

BUILDING & CONSTRUCTION - MIKE DIDONATO

FARM MANAGEMENT - JOHN EARLEY

FINANCE - SHARON LINDSAY

LEGAL & LITIGATION - FRANK GIBBONS, AL TRETTER

PUBLIC RELATIONS - SHARON LINDSAY

ROADS & GROUNDS - HENRY SUTTON

SANITATION, SHORELINE & BOAT DOCKS - RAY STANSBERRY

WATER QUALITY, SOIL CONSERVATION & RESTORATION - RAY REARDON

OLD BUSINESS - Bids on Rip Rapping Project  
- Computer for office

NEW BUSINESS

TRANSFERS: Lots 4 & 5 Block 12, Meters #87 & #87A Phil Collins & Brenda Collins to Marshall Bell & Bonnie Bell

Lots 3 & 5 Block 6, Meters #36 & #36A James Black & Diane Black to John Gordon & Sandy Gordon

Lots 3 & 1 Block 4 Meters #20 & #20A Francis S. Edwards & Florence M. Edwards to Gerald Knudson & Judith Knudson

Lot Part of 7 Block 28 Meter #223 Edna Fisher to Louis Long & Sue Long

PATROLMAN'S REPORT

NOVEMBER, 1992

- Nov. 2 Burnt leaves, cut trees for Jean Obcamp Lot #49B for 2 hours charged \$50.00; took 3 loads of broken concrete to Charles Garbin Lot #274, charged \$120.00.
- 3 Rained all day, went to get parts for tractor, had to order - Board meeting that evening.
- 4 Rain, went to see about heater and tires, got prices in Carlinville, Girard and Virden.
- 5 Rain, changed oil in truck and tractor.
- 6 John & I went to E.T. Tire Service to check on tires, had tires put on and front end lined.
- 7 Ray S. & I checked D. Miller lot #270A and other shorelines for transfers. Circo Inc. will give price on heater and installation, will be in mail Monday.
- 9 Worked on turn around for bus, worked on and got stump out - rain.
- 10 Put heat house on tractor, got dump truck ready for winter anti-freeze.
- 11 Rain - Hank S. said he had bought a heater in Springfield for \$125.00 and I need to go get fabric for turn around - more rain.
- 12 Rained all day, worked in shop.
- 13 Went to Springfield, got heater and to Williamsville to get fabric. Will have Dale Cole put heater in shed.
- 14 Waited all day for Dale Cole - No Cole.
- 16 Rain
- 17 Rain
- 18 Hank ordered rock for tomorrow.
- 19 Worked on turn around - mud, rain and a mess.
- 20 Rained all day - went and got fuel gauge for tractor and took truck to be checked, red light on - brake light - it was due to the oversized tires. Took John Miller to look at rip rap job on west side. Will be back Monday to look from the water's side.
- 21 Still no Cole.
- 23 Rainy morning - John Miller & I took Al Moore's boat out to look at shoreline.
- 24 More rain.
- 25 Worked in shop.
- 27 Started some leaves - still wet.
- 28 Ray S. & I looked at shorelines - 2 places.
- 30 Burnt leaves on North side (wet), still no Cole.

Will take my vacation December 7 - 11.

Bill Hohimer

SUNSET LAKE ASSOCIATION  
DECEMBER 1, 1992

Bills to be approved for payment:

GTE-North	- 627-3232 - \$42.61	
	- 627-3339 - <u>34.10</u>	\$ 76.71
Nilwood Water		7.75
Rural Electric		164.02
Macoupin Service Co. - fuel		255.60
Girard Auto Supply - battery terminals & filters		4.99
E. T. Tire Car Ser. - 4 truck tires		513.00
Mike Neff - 6 straw bales		9.90
Midwest Construction - fabric		278.91
State Bank of Girard - FICA & FED. W/H taxes		436.77
State Bank of Girard - petty cash		14.51
ADGPTV Water Commission - utilities		75.00
Glenda Sutton - net salary		365.50
William Hohimer - net salary		1,072.77
Madiar-Holloway Ins. - Excess Liabl. - \$	600.00	
	- Gen. Liabl. -	726.00
	- Work/Comp. -	<u>1,689.00</u>
		<u>3,015.00</u>
	Sub-Total	\$ 6,290.43
Konneker-Brown - gauge & saw parts		<u>42.92</u>
	Total	\$ 6,333.35

SUNSET LAKE ASSOCIATION  
 CASH POSITION  
 NOVEMBER 30, 1992

Cash on Hand (petty cash)		\$ 100.00
State Bank of Girard		
Checking	\$ .40	
Money Market Fund - General	12,782.60	
- Interest	<u>39.80</u>	
		<u>\$ 12,822.80</u>
Total General Revenue		\$ 12,922.80
State Bank of Girard		
Money Market Fund - Special (Dam)	\$ 15,281.51	
- Interest	<u>38.10</u>	
		\$ 15,319.61
Money Market Fund - Equipment Reserve		<u>2,375.00</u>
Total Revenue		<u>\$ 30,617.41</u>
State Bank of Girard - escrow		<u>\$ 2,000.00</u>

Monthly Receipts:

Assessments - General	\$ -0-	
- Island	-0-	
Boat Permits	245.00	
Building Permits	-0-	
Fines & Penalties	-0-	
Transfer Fees	400.00	
Earned by Maintenance Man	174.00	
Misc. Income - REA flood lights	75.00	
- RV Vehicle Fee - 1993	<u>5.00</u>	
Total		<u>\$ 899.00</u>

SUNSET LAKE ASSOCIATION

Comparison of Annual Budget  
For Period From January 1, 1992 to December 1, 1992

<u>RECEIPTS:</u>	<u>Annual Budget</u>	<u>Year To Date</u>	<u>Over or (Under) Budget</u>
General Assessments	\$ 38,690.00	\$ 37,812.69	\$ (877.31)
Building Permits	400.00	1,185.00	785.00
Fines & Penalties	300.00	417.89	117.89
Farm Income	2,500.00	3,172.06	672.06
Interest	3,500.00	1,283.56	(2,216.44)
Transfer & Lease Fee	2,800.00	5,200.00	2,400.00
Boat Permits (Year 2 of 2 yr. per.)	2,000.00	497.00	(1,503.00)
Cablevision	1,300.00	1,226.24	(73.76)
Earned by Maintenance Man	500.00	1,568.32	1,068.32
Other Receipts	400.00	388.00	(12.00)
Total Revenue	<u>\$ 52,390.00</u>	<u>\$ 52,750.76</u>	<u>\$ 360.76</u>

EXPENDITURES:

Patrol/Main't Man's Salary	\$ 16,065.00	\$ 16,065.00	\$ -0-
Secretary's Salary	5,407.50	5,407.50	-0-
Legal & Accounting Fees	4,000.00	3,785.40	(214.60)
Office Rent	900.00	900.00	-0-
Postage, Printing & Office Exp.	1,800.00	1,407.98	(392.02)
Maintenance: Lake	1,000.00	184.86	(815.14)
Roads	1,000.00	278.91	(721.09)
Grounds	1,000.00	467.25	(532.75)
Equipment	1,800.00	1,772.76	(27.24)
Conservation/W'shed	2,000.00	-0-	(2,000.00)
Gas & Oil	1,800.00	1,522.48	(277.52)
Maintenance Exp. & Supplies	200.50	56.19	(144.31)
Farm Expense	250.00	469.23	219.23
Fish Stocking	1,000.00	1,000.00	-0-
Utilities	2,500.00	2,593.24	93.24
Insurance	4,867.00	5,956.00	1,089.00
Employment Taxes	1,750.00	1,819.42	69.42
Property Taxes	2,050.00	2,335.18	285.18
Misc., Interest Exp, Mileage & Etc.	500.00	965.48	465.48
Equipment Reserve	2,500.00	125.00	(2,375.00)
Total Expenditures	<u>\$ 52,390.00</u>	<u>\$ 47,111.88</u>	<u>\$ (5,278.12)</u>



SUNSET LAKE ASSOCIATION  
 CASH POSITION  
 DECEMBER 31, 1992

Cash on Hand (petty cash)		\$ 100.00
State Bank of Girard		
Checking	\$ .53	
Money Market Fund - General	7,887.40	
- Interest	<u>28.13</u>	
		<u>\$ 7,916.06</u>
Total General Revenue		\$ 8,016.06 *
State Bank of Girard		
Money Market Fund - Special (Dam)	\$ 15,319.61	
- Interest	<u>38.19</u>	
		\$ 15,357.80
Money Market Fund - Equipment Reserve		<u>\$ 2,375.00</u>
Total Revenue		<u>\$ 25,748.86</u>
State Bank of Girard - escrow		<u>\$ 11,500.00</u>

\* \$4,550.96 balance after December bills subtracted

Monthly Receipts:

Assessments - General	\$ -0-	
- Island	-0-	
Boat Permits	-0-	
Building Permits	-0-	
Fines & Penalties	50.00	
Transfer Fees	800.00	
Earned by Maintenance Man	130.00	
Misc. Income - Chlorine Tablets	8.00	
- Class A Memberships	<u>800.00</u>	
Total		<u>\$ 1,788.00</u>

SUNSET LAKE ASSOCIATION

JANUARY 5, 1993

Bills to be approved for payment:

Rural Electric	\$	165.29
Nilwood Water		7.75
GTE-North- 627-3232 - \$42.16		
- 627-3339 - <u>33.31</u>		75.47
Wheeler-Ross Hardware - propane tank fee & fuel		209.38
Smoky Jennings Chev. - repair on dash brake light		10.11
Morris Stults Ser. - bus turnaround rock		1,668.38
Stamped Envelope Agency - regular envelopes		160.00
American Decal Co. - boat decals		733.24
Illinois Department of Conservation - fishing permit		50.00
Girard Hardware - bolts & keys		4.40
ADGPTV Water Commission - utilities - \$75.00		
- address chg. <u>7.28</u>		82.28
Smoky Jennings Chev. - repairs on right tail light		53.56
Illinois Department of Revenue - IL. W/H Taxes		153.63
State Bank of Girard - Fed. & FICA W/H Taxes		436.79
State Bank of Girard - petty cash		15.45
Illinois Director of Employment Security - unemployment taxes		8.11
Internal Revenue Service - FUTA Tax		99.26
Glenda Sutton - net salary		396.80
William Hohimer - net salary		<u>1,103.73</u>
	Sub-Total	\$ 5,433.63
Snell Enterprises - installing heater		359.07
Morris Stults Ser. - rock		159.86
Girard Auto Supply - truck light		21.72
Madiar-Holloway Insurance - Fire		136.00
- Equip & Tools		968.00
- Boat & Equipment		<u>494.00</u>
	Total	\$ 7,572.28

PATROLMAN'S REPORT

DECEMBER, 1992

- Dec 1 I worked on bus turnaround, worked rock and put down felt.  
2 Rained all day hard, worked in shop.  
3 Checked on heater, got more rock.  
4 Finished turnaround, got truck and tractor ready for next week - will be gone on vacation.  
14 Cleared up cans and bottles along roads, tighten bolts on guard rail that Hank and John and Ray put up when I was gone.  
15 Added rock to bus turnaround.  
16 Put stand outs on guard rail to add more post, got head light and fixed truck, tail light is also out.  
17 Hauled rock around lake, fixed pot holes.  
18 Ray & I put in more post on guard rail.  
19 Got heat in shop and working.  
21 Took up old cable and picked old post from oil guard rail.  
22 Hauled rock and added to turnaround and pot holes.  
23 Got winter patch and fixed corner on West Lake Dr. and got tail light fixed.  
24 Picked limbs and trash up.  
28 Put more rock on bus turnaround on West Lake Dr.  
29-31 Picked up Xmas Trees, more rain.

Bill Hohimer