

10 Ton Lime Spreader

Overall Width	96"
Overall Length (No attachment)	20'
Hopper Length	11'
Overall Height	92"
Capacity (Heaped)	10 cu yd
Maximum Spread Width	30' - 40' (Depending on Material)
Top Width of Hopper	75"
Side Angle	60°
Wheel and Tire	21.5L-16.1SL x 10 Ply Tire on 8 Bolt Wheel
Empty Weight	6,000 lbs
Payload	10 Ton (20,000 lbs)
Wheel Base	77" Center to Center
Hopper	12 Ga. Steel Hopper (Stainless Optional)
Floor Chain	30" Floor Chain with Slats every other link
Hydraulic Gearbox Gearbox	Dual Drive 6:1 Reduction
Hydraulics	Double 15 GPM PTO Pump
Optional Attachments	Dual Spinner, Deflector, Conveyor, Flicker

Adjustable Endgate
4 Optional Attachments



Stainless Hopper and Spinners (Optional)



Easy to Use Flow Control
for Apron and Spinners

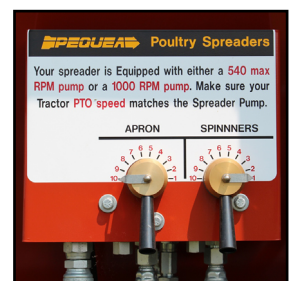

Digistar Rate Controller (Optional)



10 Ton Lime Spreader Attachments

Dual Conveyor

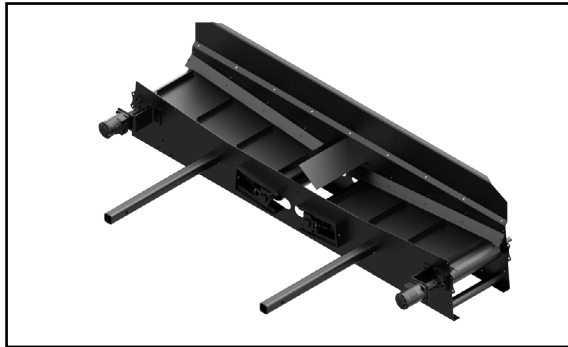

Dual Spinner

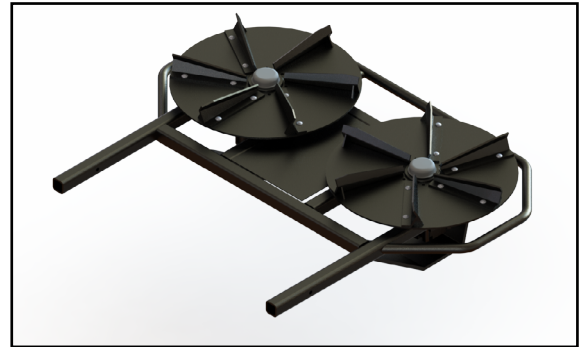

Dual Conveyor with Flicker

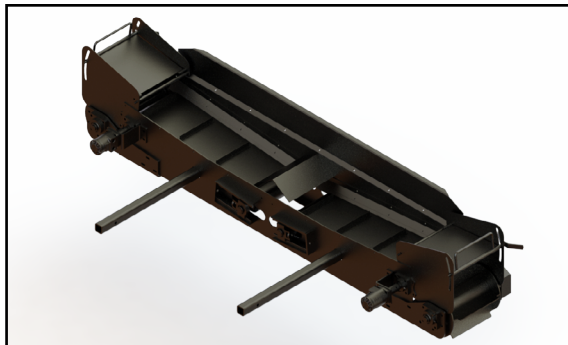

Dual Spinner with Deflectors

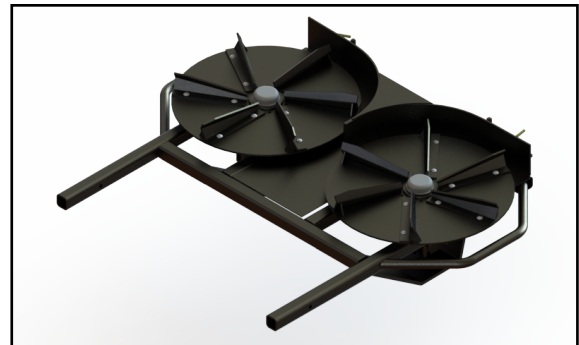

Bidirectional Single Conveyor

