

A close-up photograph of a person's hand gripping a metal fence post. The hand is positioned on the left side of the frame, with fingers wrapped around the post. The fence consists of several horizontal metal rails and a vertical post. In the background, there is a chain-link fence and a blurred outdoor setting. A black rectangular box with a blue border is overlaid on the right side of the image, containing the text "EVOLVE FENCING" in white, bold, uppercase letters.

**EVOLVE
FENCING**

Our company

Our Company has the systems, resources and expertise to undertake multiple projects. Our dedicated team is committed to deliver projects on time, on budget and to the highest standard and strive for continual improvement in all areas.

Through the implementation of our integrated systems and our focus on ethical business practices and customer service, we provide assurance to our clients that our products and service will not only meet but often exceed customer expectation.

Our new technology in this sector brings a new level of full service for all your requirements.



Our company



Our fencing comes from our sister company in South Africa which is fully BBE* compliant and is working hard towards net zero.

Our products are made to the highest standards and have been proven throughout the African continent, in some of the harshest environments known to humanity where poverty drives crime, that poverty also drives criminals intent on achieving their goal at any cost, our fencing has proven its self in deterring theft and securing our clients assets. Due to a favourable exchange rates our products are not only high quality but also cheaper than our competitors.

*(BEE Black Economic Empowerment)

Unique fencing



Value, Safety and Security

Safety and security is important because both have an affect on the individual's well-being.

Safety is freedom from physical or emotional harm. Security is critical to both residential and business operations.

We provide not only safety and security, but also value based on cost of service and latest technology as bolt on additions.

Bespoke Products

We offer customizable goods or services built to the customer's specific requirements. All our products are infinity upgradable to the ever-changing security threats.

No need to replace the complete system.

Synonymous with quality

Our products are brought about by strict and consistent standards to achieve the highest standards currently available.

Unique Structure

3mm x 3mm 3mm x 4mm
4mm x 4mm 5.6mm x
5.6mm

Unique fencing Galvanised/plascoat



Our unique Plascoat coating ensures that the base wire is coated to perfection using the very latest Plascoat technology. This process ensures a bond to the base metal to ensure no moisture can penetrate between base metal and Plascoat. This ensures a long life span in very hostile environments.

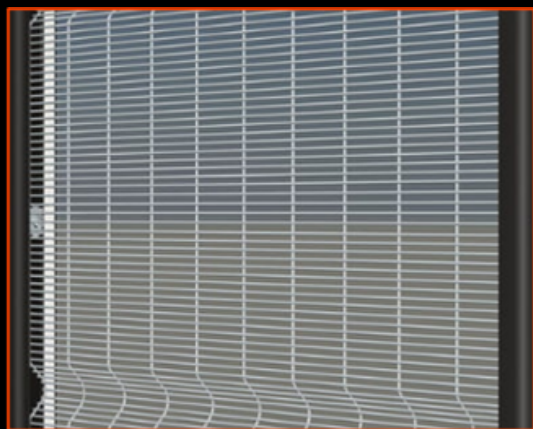

Mesh Size 76mm x 12.7mm

- Installation Height:
1800mm, 2100mm, 2400mm, 3000mm
- Embedded Post Height:
2400mm, 2700mm, 3000mm, 3600mm
(600mm below the ground level)
- Post Centre Distance: 3000mm
- Distance Between the Horizontal Wires:
12.7mm \pm 1.0mm, 25.0mm \pm 1.0mm, 50.0mm \pm 1.0mm
- Distance Between the Vertical Wires: 76 \pm 3.0mm

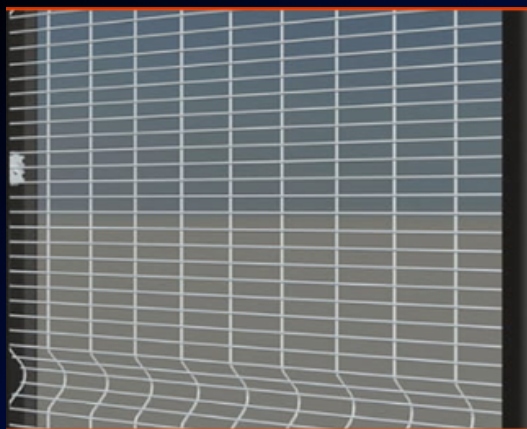

Mesh Size 76mm x 25mm

- Core Diameter of the Horizontal Galvanized Wire:
3.00mm \pm 0.10mm
- Core Diameter of the Vertical Galvanized Wire:
4.00mm \pm 0.10mm
- Metallic Coating:
the wires are pre galvanized and the min zinc weight
for the horizontal and vertical wires is 250gsm
- Powder Coating / PVC Coating

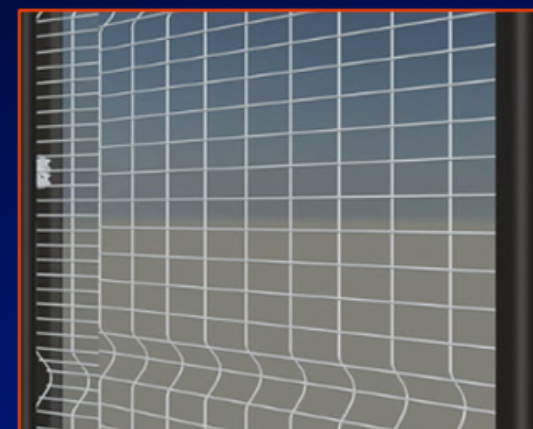

Mesh Size 76mm x 50mm

RE-INFORCED SYSTEM

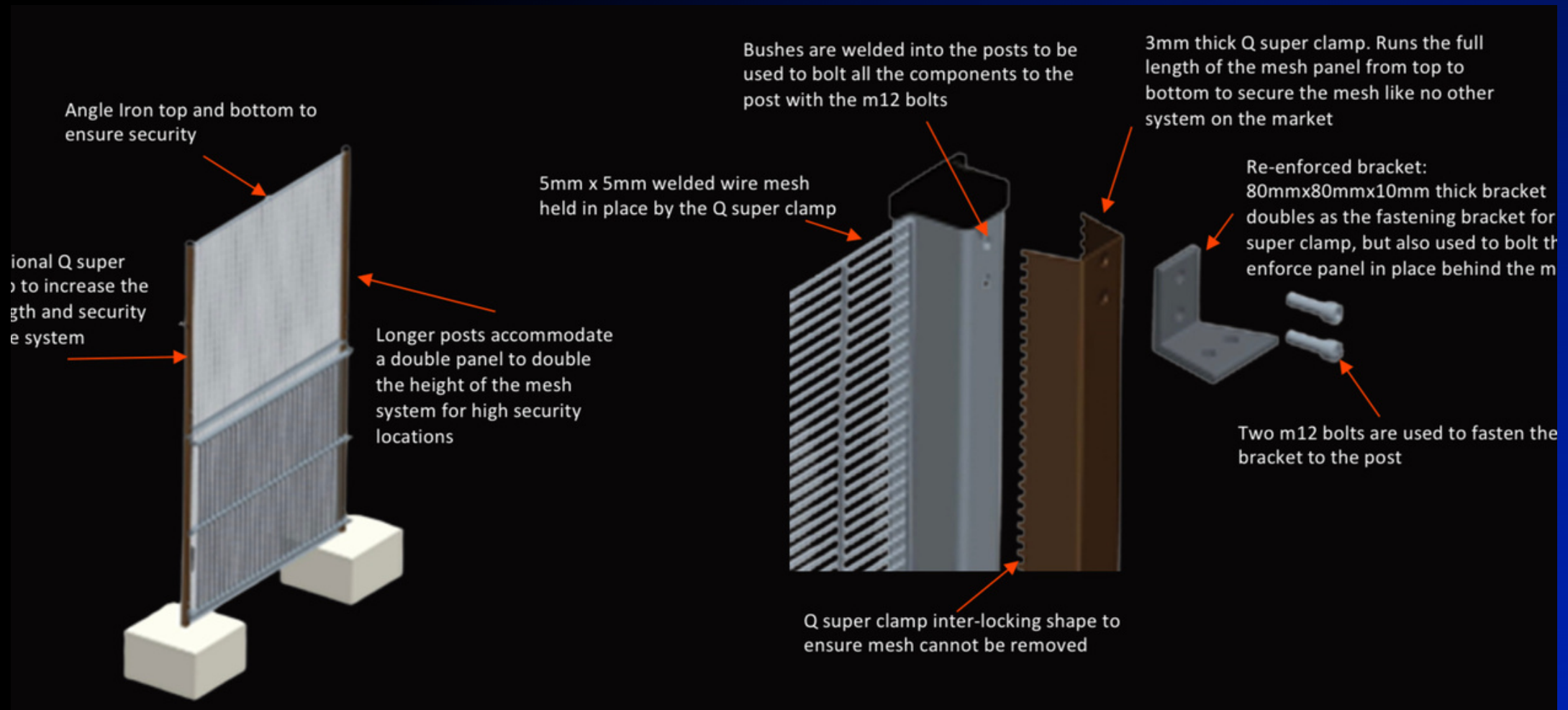

RE-INFORCED SYSTEM

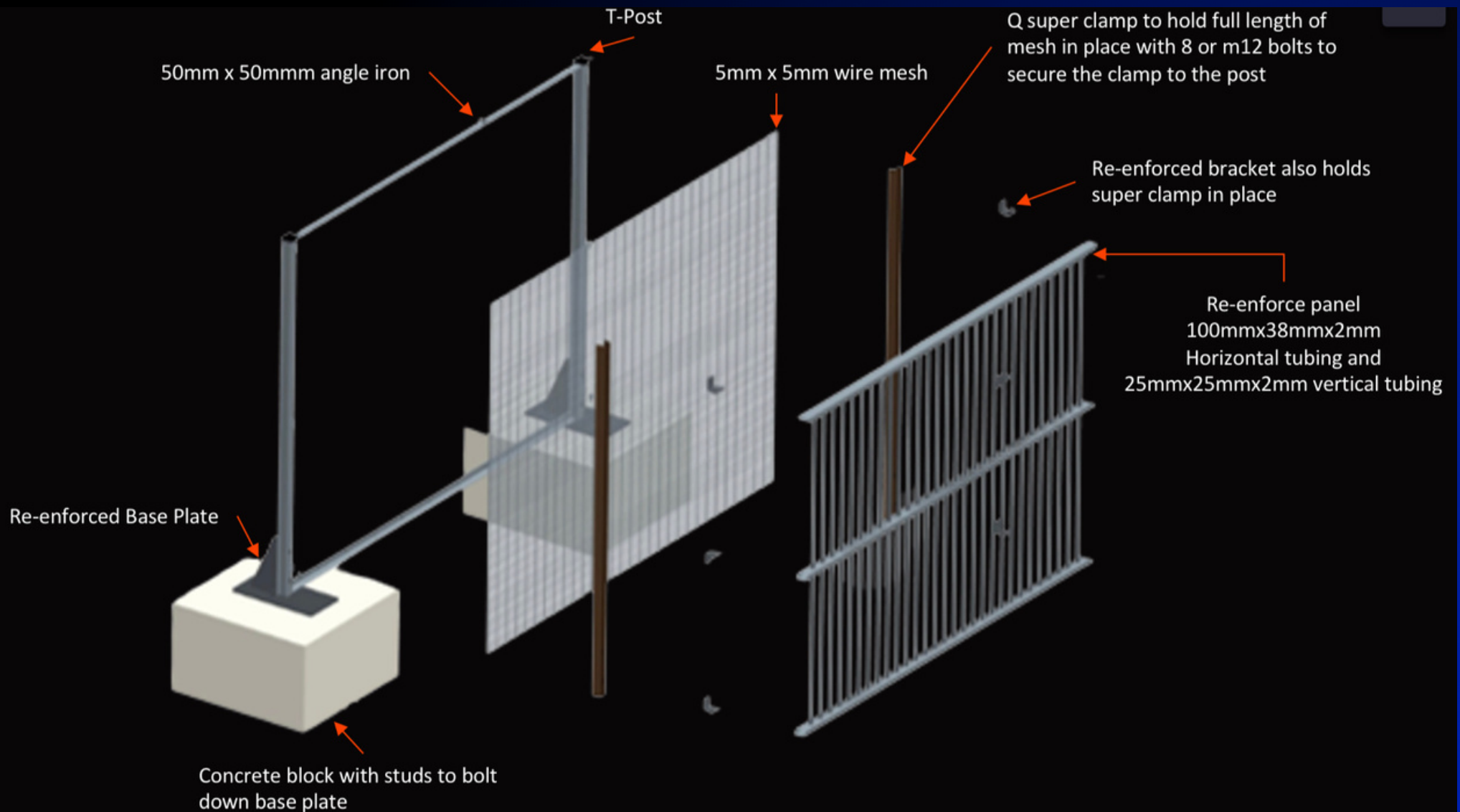

Q View Max



Military spec.

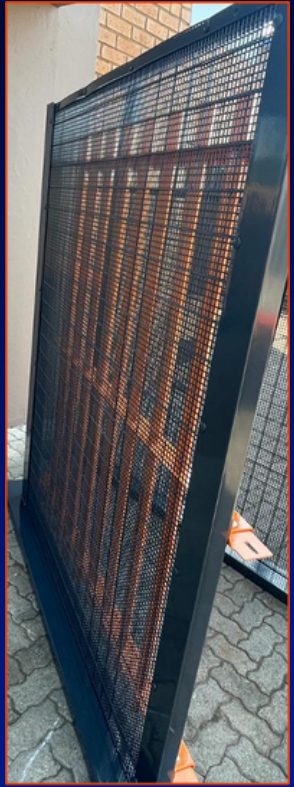
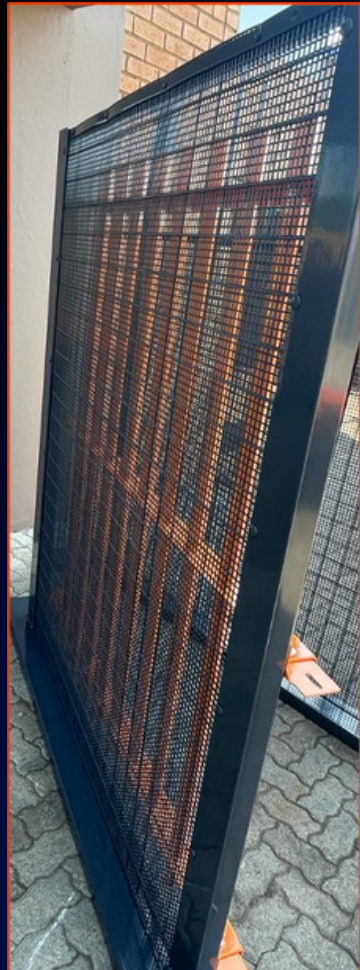

Super Secure Q Fence



Our clamps T posts and spikes



Razor wire & Qmesh



Razor wire specification

Available in Sheet Height: 1200mm, 1800mm, 2100mm, 2400mm

Sheet Length: 6000mm

Galvanized Steel Thickness: 0.30mm – 0.50mm ± 0.10mm

Galvanized Wire Diameter: 2.4mm – 2.5mm ± 0.10mm

Standard Volume Aperture: 150mm – 300mm

High Volume Aperture: 75mm – 150mm

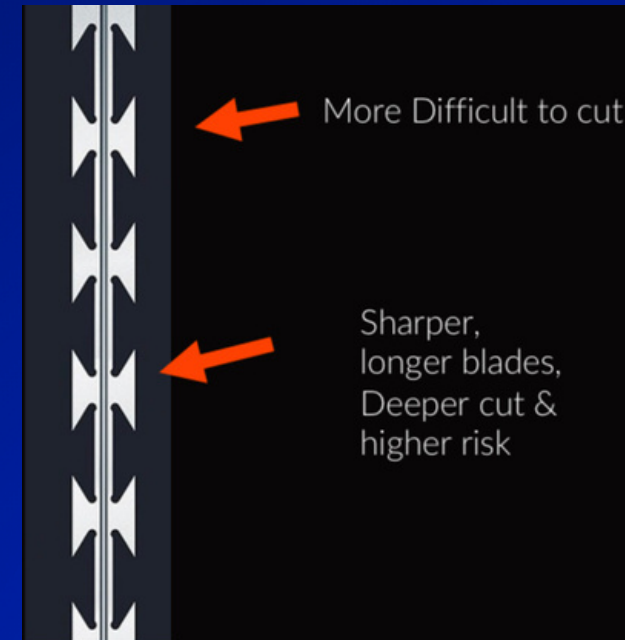
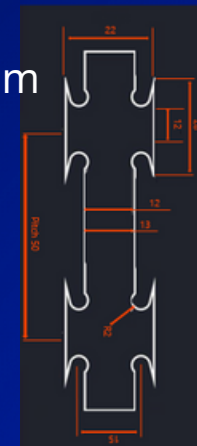

Chain link fence



Chain link specification

Coating: Fully or Lightly Galvanized

Wire Diameter: 2mm/2,5mm
(Standard)

Sizes: 50mm

Roll Widths: Available in widths from
900mm to 3000mm

Gates

Our gates are made to ensure strength and security and meet the clients' requirements. We manufacture two levels of protection. Residential will be a lighter manufactured gate as the threat is significantly less than a commercial structure. Client can choose.

We offer: Double Leaf Swing Gates; Sliding Gates and Pedestrian Gates.

Gate Rails are Light Duty or Heavy Duty.

The Lock Box Device (optional) stops criminals tampering with the lock by limiting the area to tamper.



Heavy Duty Public Order Gates

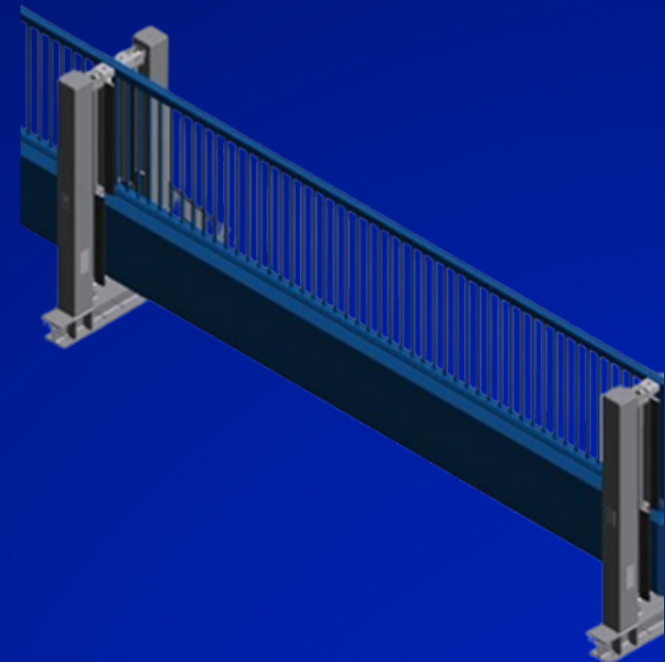

Rapid Deployment Trailers



The razor wire trailers are designed for the rapid deployment of effectively layered concertina coils. This is a serious obstacle for rebels or demonstrators and vehicles to gain entry.

Razor wire rapid deployment barrier system is available in 3 coil configurations (3 coils = gives 1.7m high protection for 100m distance).

The operation of the razor wire deployment trailer is simple and convenient.

Connected to the vehicle through the axis of traction and can be hitched on any type of vehicle.

The next step will be to open the tall gate or release the barrier holder frame and drive forward automatically releasing and stretching the concertina coil barrier. This can be repeated with additional cassettes of wire from the same trailer to increase coverage.

Rapid Deployment Trailers

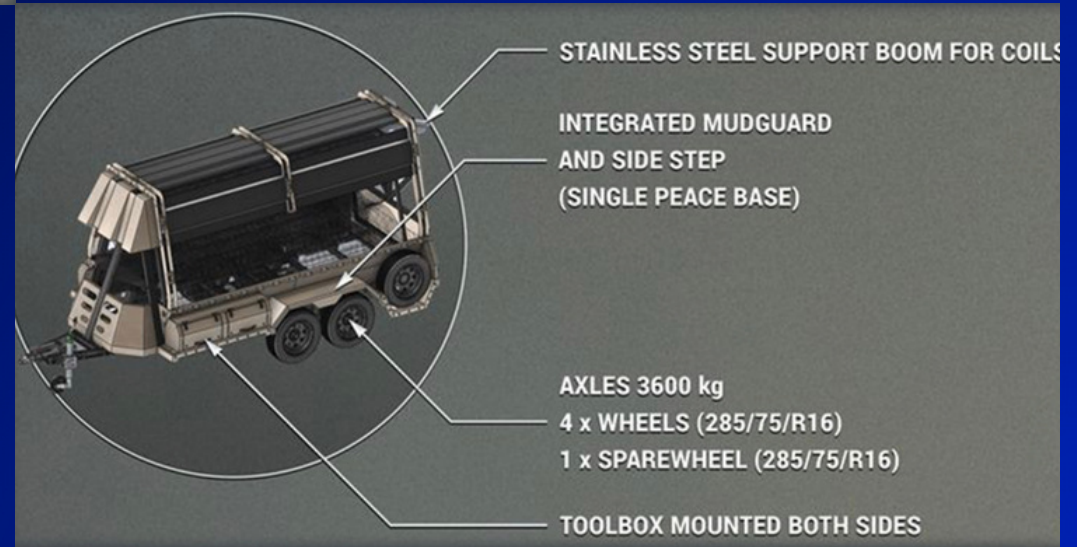
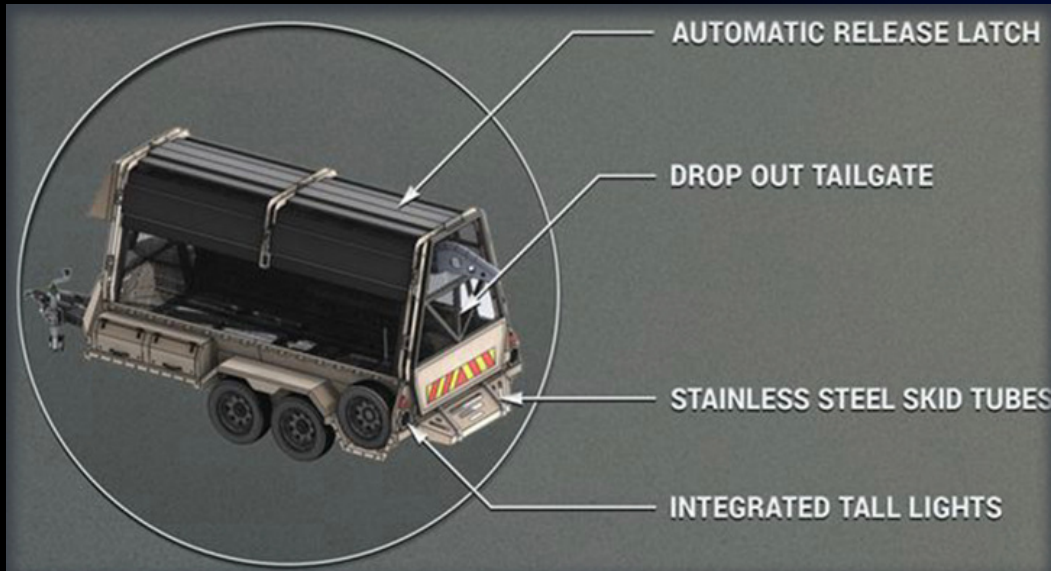

Rapid Deployment Trailers

Wire patterns and configurations.

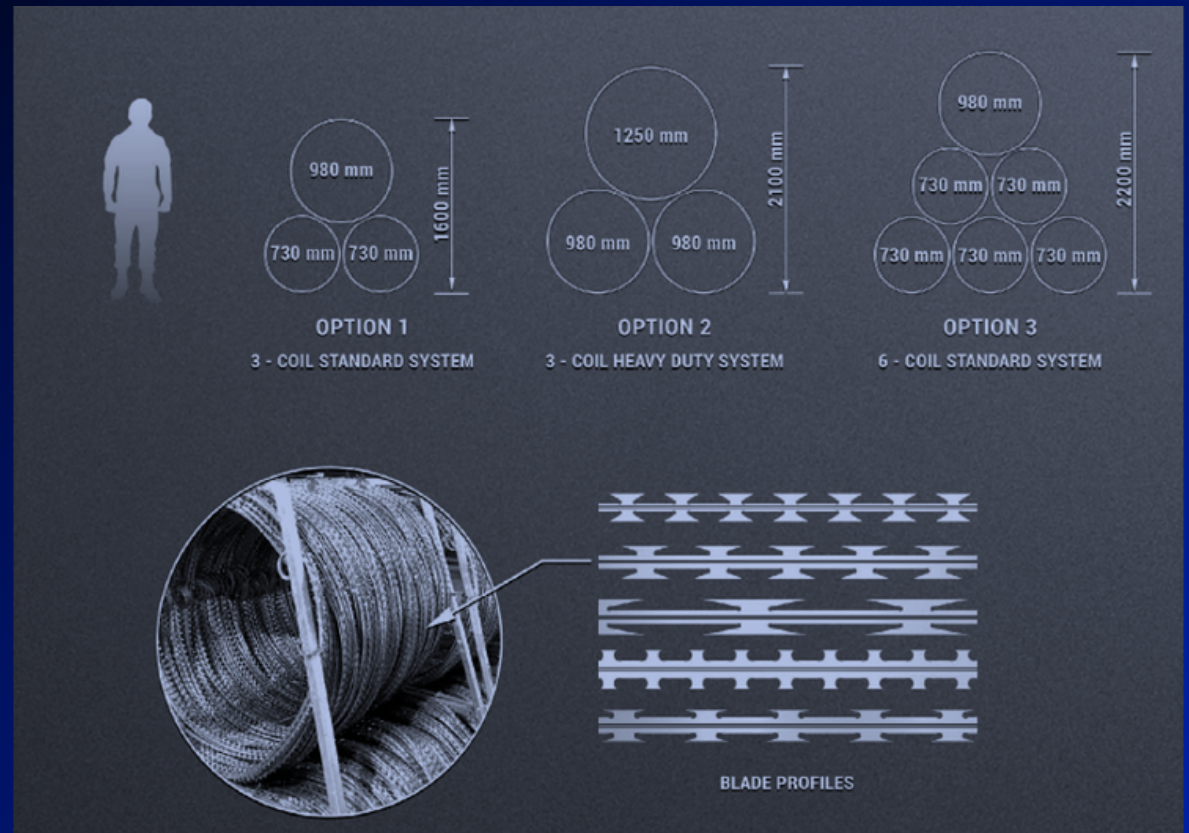
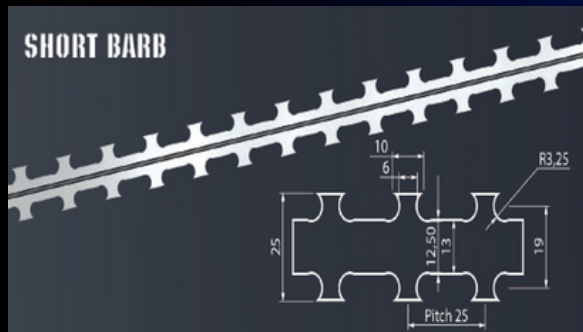
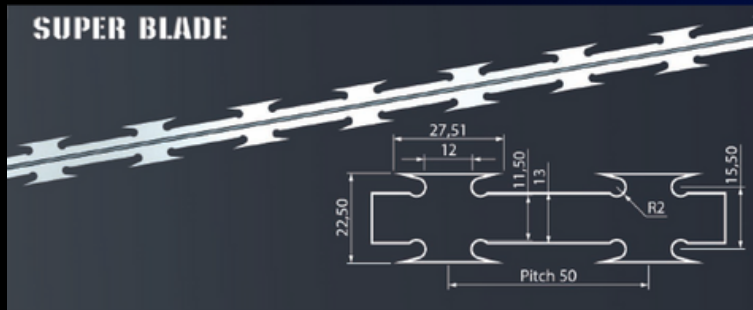
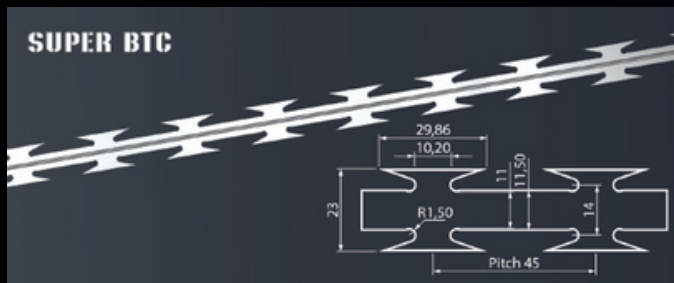

Contact us

www.evolve-srm.com/evolve-fencing

email:-consultants@evolve-srm.com

tel. Dean Taylor 07850287018

