

INSTALLATION INSTRUCTIONS – ADAPTER PLATE

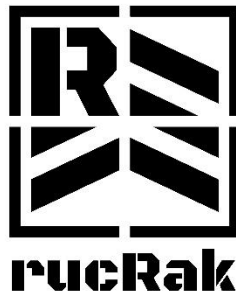

MULTIPURPOSE RACK SYSTEM
U.S. PATENT PENDING

CAUTION

ENSURE THAT YOUR VEHICLE IS EQUIPPED TO HANDLE EXCESSIVE WEIGHT FROM THE ADDITION OF NON-FACTORY ASSESSORIES.

USE OF THIS MULTIPURPOSE RACK SYSTEM IS AT THE OWNER'S RISK.

rucRak Inc. ASSUMES NO LIABILITY FOR VEHICLE DAMAGE, PROPERTY DAMAGE OR PERSONAL INJURY WHILE USING THIS PRODUCT.

THIS MULTIPURPOSE RACK SYSTEM IS INTENDED FOR OFF-ROAD USE ONLY. PLEASE FOLLOW ALL STATE AND LOCAL DOT LAWS WHILE USING THIS PRODUCT.

INSTALLATION NOTES

CAREFULLY READ ALL INSTRUCTIONS THOROUGHLY BEFORE ATTEMPTING TO INSTALL THESE PARTS AND ASSESSORIES.

ASK A FRIEND FOR HELP. HAVING A HELPING HAND WILL ALLOW FOR AN EASIER INSTALLATION AND MINIMIZE POTENTIAL INJURY WHILE HANDLING HEAVY PARTS.

BE SURE TO LUBRICATE ALL STAINLESS STEEL HARDWARE PRIOR TO INSTALLATION.

ONLY HAND-TIGHTEN THE HARDWARE UNTIL ALL PARTS ARE FULLY ASSEMBLED.

VIDEO DEMONSTRATIONS OF INSTALLATIONS AND CONFIGURATIONS CAN BE FOUND ON OUR WEBSITE.

FOR TECHNICAL SUPPORT AND WARRANTY INFORMATION, PLEASE VISIT OUR WEBSITE.

WWW.RUCRAK.COM

ADAPTER PLATE INSTALLATION (FIG. 3)

PARTS INCLUDED PER (1 SET) ADAPTER PLATES		
ITEM	ITEM DESCRIPTION	QTY
301	ADAPTER PLATE - LEFT	1
302	ADAPTER PLATE - RIGHT	1
303	5/16"-18 x 2" LG CAP SCREW W/2 WASHERS & NYLON INSERT LOCKNUT	4
304	KNOB	2
305	3/8"-16 x 2-1/2" LG BOLT W/2 WASHERS & NYLON INSERT LOCKNUT	4

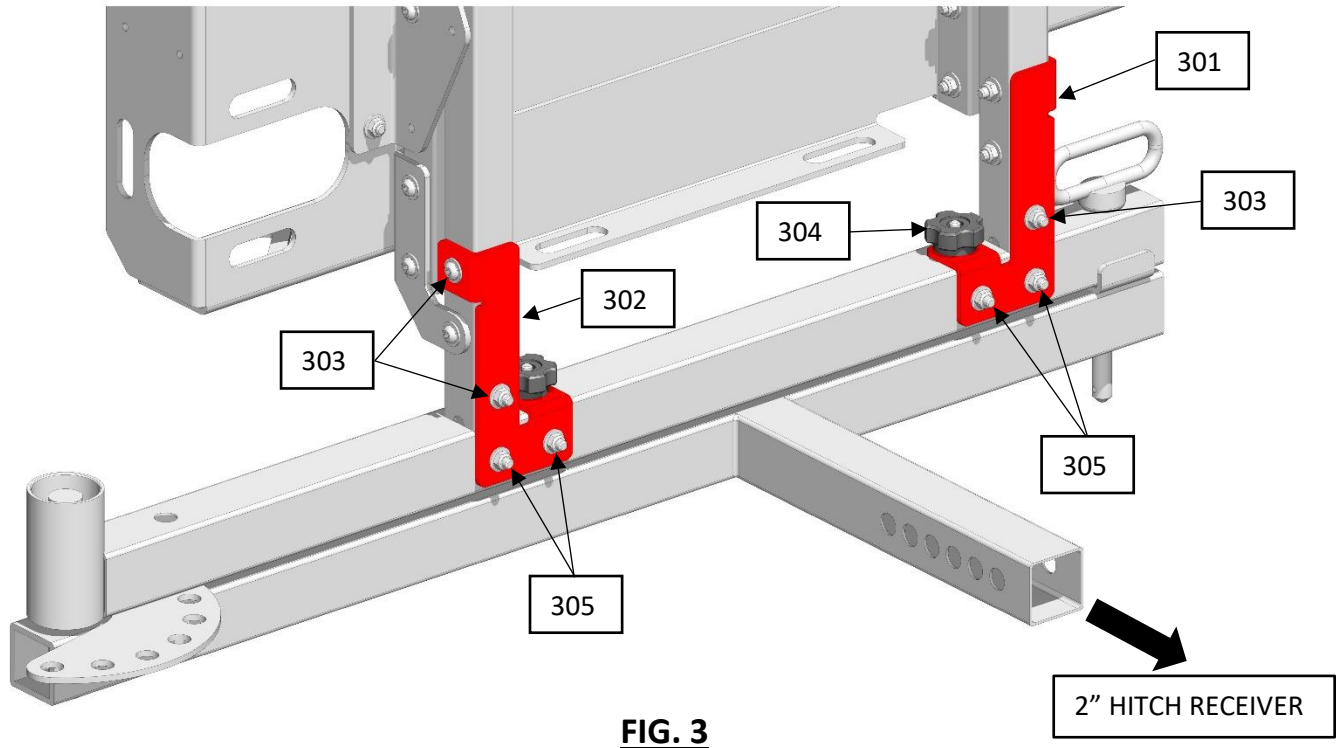

NOTE: MAKE SURE THE SWING ARM ASSESSORY IS ALREADY INSTALLED ON YOUR VEHICLE.

STEP 1: INSTALL THE LEFT AND RIGHT ADAPTER PLATES (ITEMS 301 & 302) ONTO THE VERTICAL LEGS AS SHOWN USING THE SUPPLIED 5/16" HARDWARE (ITEM 303).

STEP 2: WITH THE SWING ARM SECURED IN THE CLOSED POSITION, LOCATE THE 2 THREADED STUDS ON THE UPPER SWING ARM AND POSITION THE HORIZONTAL TOES OF THE ADAPTER PLATES (ITEMS 301 & 302) OVER THE 3/8" THREADED STUDS. HAND TIGHTEN WITH THE SUPPLIED KNOBS (ITEM 304).

STEP 3: USING THE SUPPLIED 3/8" HARDWARE (ITEM 305), COMPLETE THE INSTALLATION BY BOLTING THE ADAPTER PLATES TO THE REMAINING 4 HOLES IN THE UPPER SWING ARM.

NOTE: CORRECT INSTALLATION WILL ALLOW THE BASKET TO OPEN UP AWAY FROM THE VEHICLE WHILE THE SWING ARM IS IN THE CLOSED POSITION.