

CT-1 | CTD-1 | CTA-1

TOROIDAL CURRENT TRANSFORMERS

GENERAL CHARACTERISTICS

The differential earth relays CT-1 can be connected to the following toroidal current transformers. They must be crossed by the cables of the line to be controlled; insert the phases and neutral if present. The earth cable must NOT cross the current transformer.

NOTE: Twist the connection wires between the toroid and the relay, keep them away from the power cables, and in the presence of strong electromagnetic fields use a shielded lead. Separately twist the pair of signal cables (terminals 1-2) from the control circuit pair (terminals 3-4) where present. Reduce the distance between the toroid and the relay to the minimum.

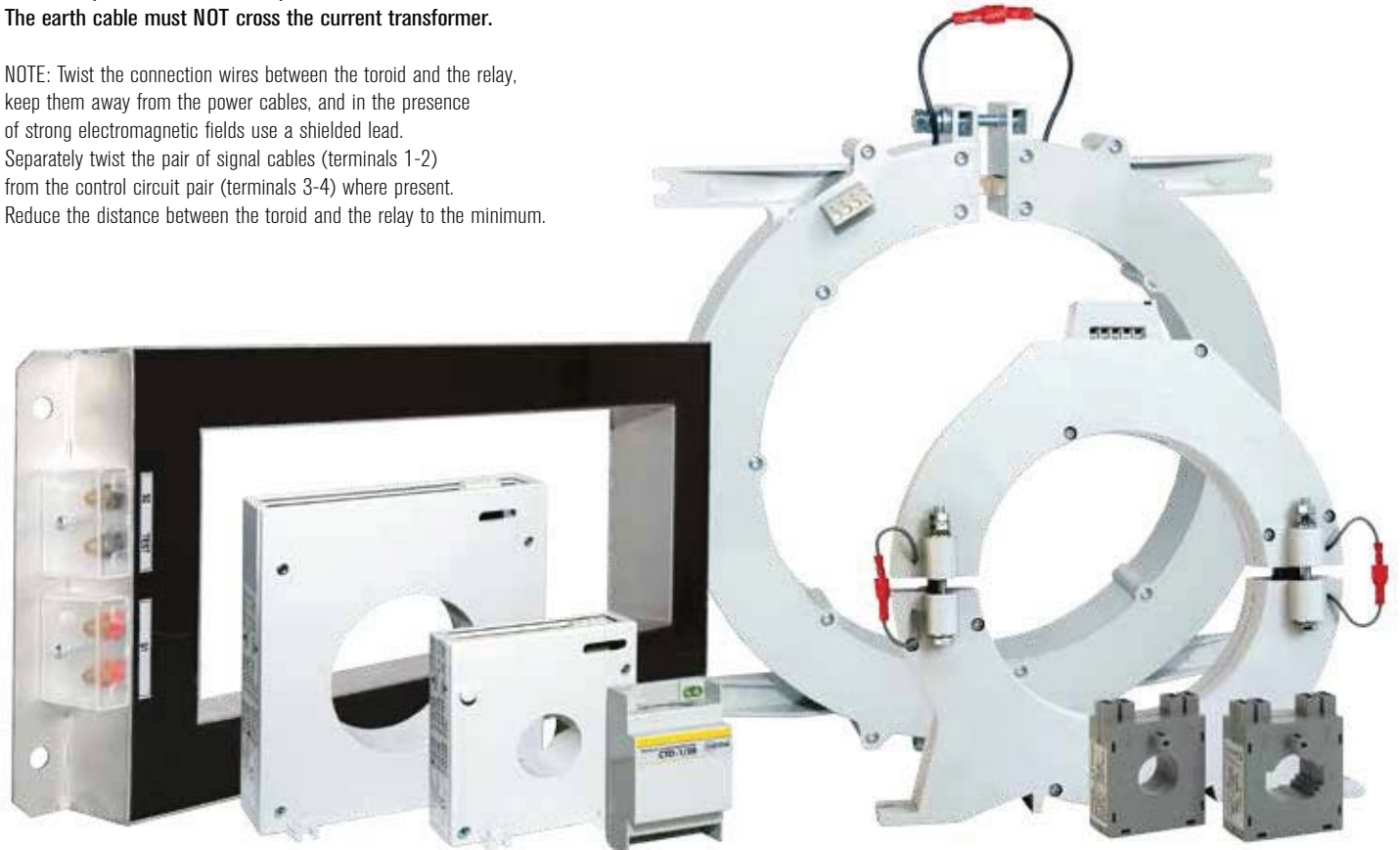

CTD-1/28

ORDER CODE	DIAMETER (mm)	CORE	WEIGHT (kg)
CTD-1/28	28	SOLID CORE	0,200

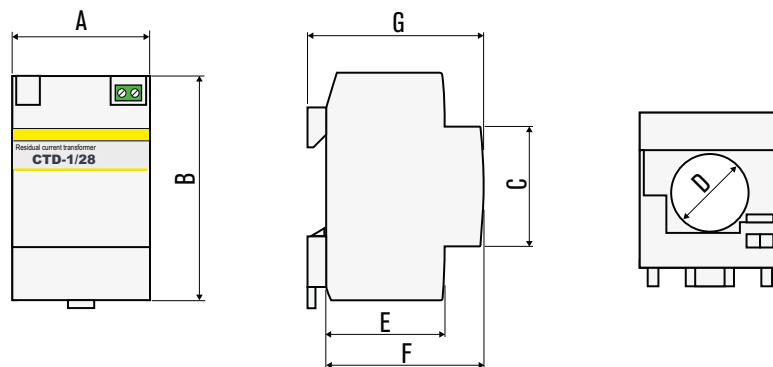

TYPE - DIMENSIONS (mm)	A	B	C	D	E	F	G
CTD-1/28	52,5	85,5	45	28	44	58	54

CT-1/22

ORDER CODE	DIAMETER (mm)	CORE	WEIGHT (kg)
CT-1/22	22	SOLID CORE	0,150

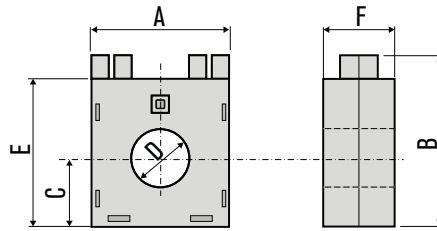

TYPE - DIMENSIONS (mm)	A	B	C	D	E	F
CT-1/22	52	65	26	22	56	27

CT-1/35 | CT-1/60 | CT-1/80 | CT-1/110 | CT-1/160

ORDER CODE	DIAMETER (mm)	CORE	WEIGHT (kg)
CT-1/35	35	SOLID CORE	0,220
CT-1/60	60	SOLID CORE	0,280
CT-1/80	80	SOLID CORE	0,450
CT-1/110	110	SOLID CORE	0,520
CT-1/160	160	SOLID CORE	1,350

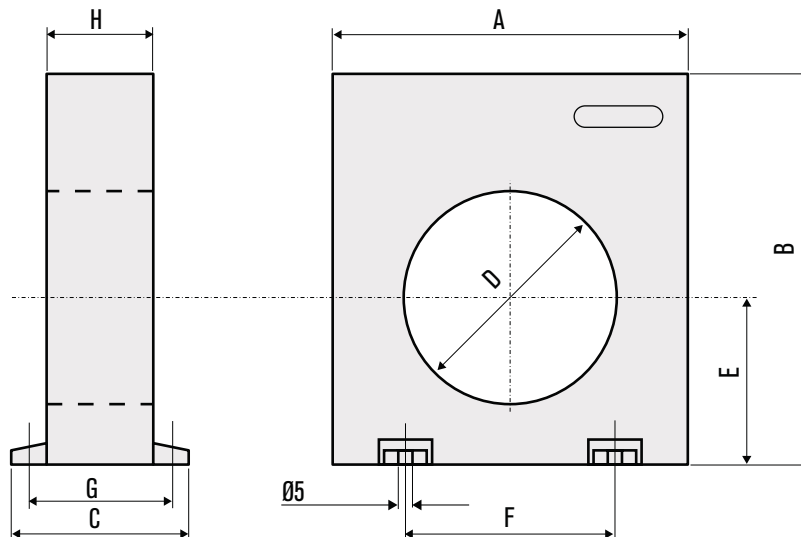

TYPE - DIMENSIONS (mm)	A	B	C	D	E	F	G	H
CT-1/35	100	110	50	35	47	60	43	30
CT-1/60	100	110	50	60	47	60	43	30
CT-1/80	150	160	50	80	70	110	43	30
CT-1/110	150	160	50	110	70	110	43	30
CT-1/160	220	236	64	160	110	156	50	34

CTA-1/110

ORDER CODE	DIAMETER (mm)	CORE	WEIGHT (kg)
CTA-1/110	110	SPLIT CORE	0,600

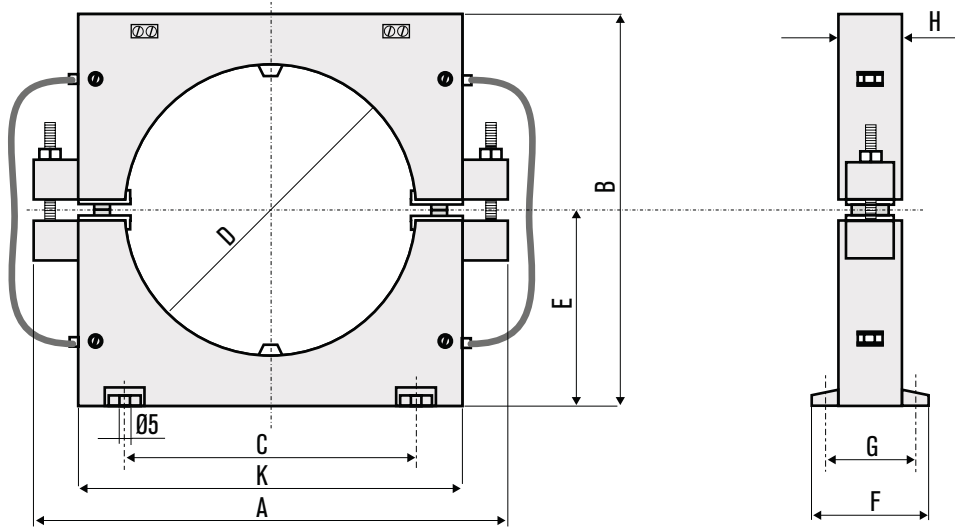

CTA-1/160

ORDER CODE	DIAMETER (mm)	CORE	WEIGHT (kg)
CTA-1/160	160	SPLIT CORE	1,600

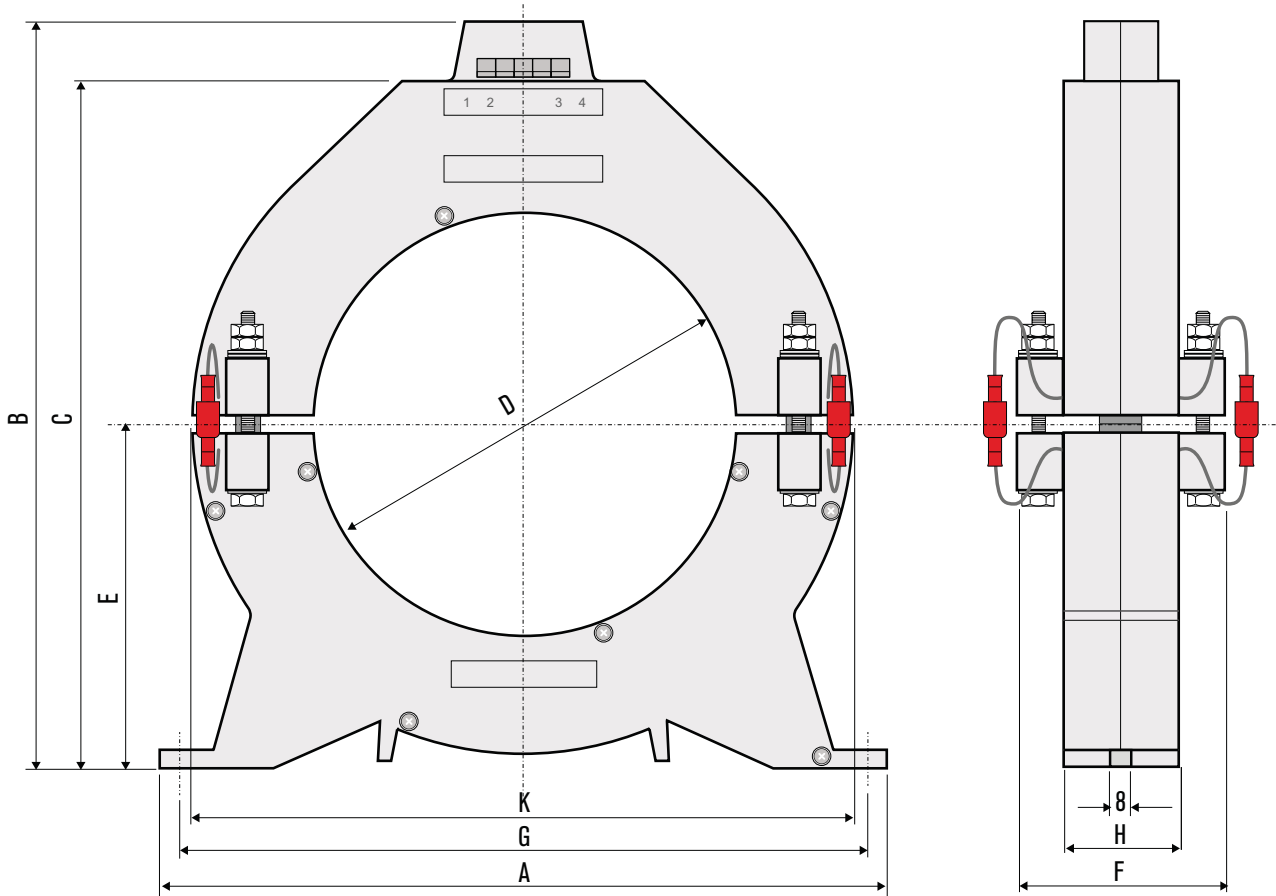

TYPE - DIMENSIONS (mm)	A	B	C	D	E	F	G	H	K
CTA-1/110	180	150	110	110	75	45	38	25	145
CTA-1/160	275	280	260	160	129	75	260	43,5	250

CT-1/210 | **CTA-1/210** | **CT-1/300** | **CTA-1/300**

ORDER CODE	DIAMETER (mm)	CORE	WEIGHT (kg)
CT-1/210	210	SOLID CORE	1,450
CT-1/300	300	SOLID CORE	2,100
CTA-1/210	210	SPLIT CORE	1,850
CTA-1/300	300	SPLIT CORE	2,300

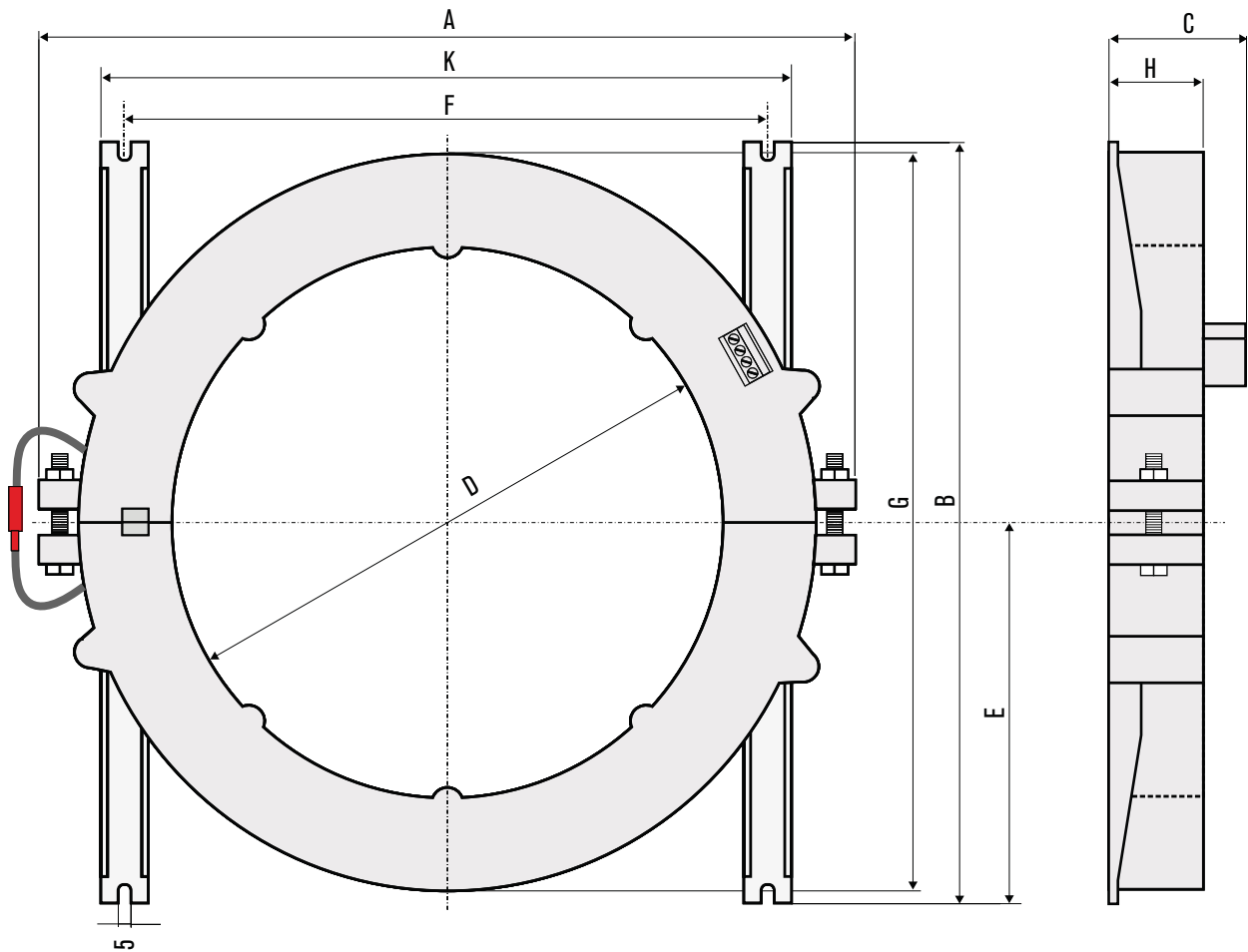

TYPE - DIMENSIONS (mm)	A	B	C	D	E	F	G	H	K
CT-1/210	310	290	54	210	145	240	280	36	258
CT-1/300	416	385	60	300	190	350	365	42	366
CTA-1/210	310	290	54	210	145	240	280	36	258
CTA-1/300	416	385	60	300	190	350	365	42	366

CT-1/280R | CT-1/350R | CT-1/415R

ORDER CODE	DIAMETER (mm)	CORE	WEIGHT (kg)
CT-1/280R	280 x 150	SOLID CORE	1,700
CT-1/350R	350 x 170	SOLID CORE	2,100
CT-1/415R	400 x 150	SOLID CORE	8,300

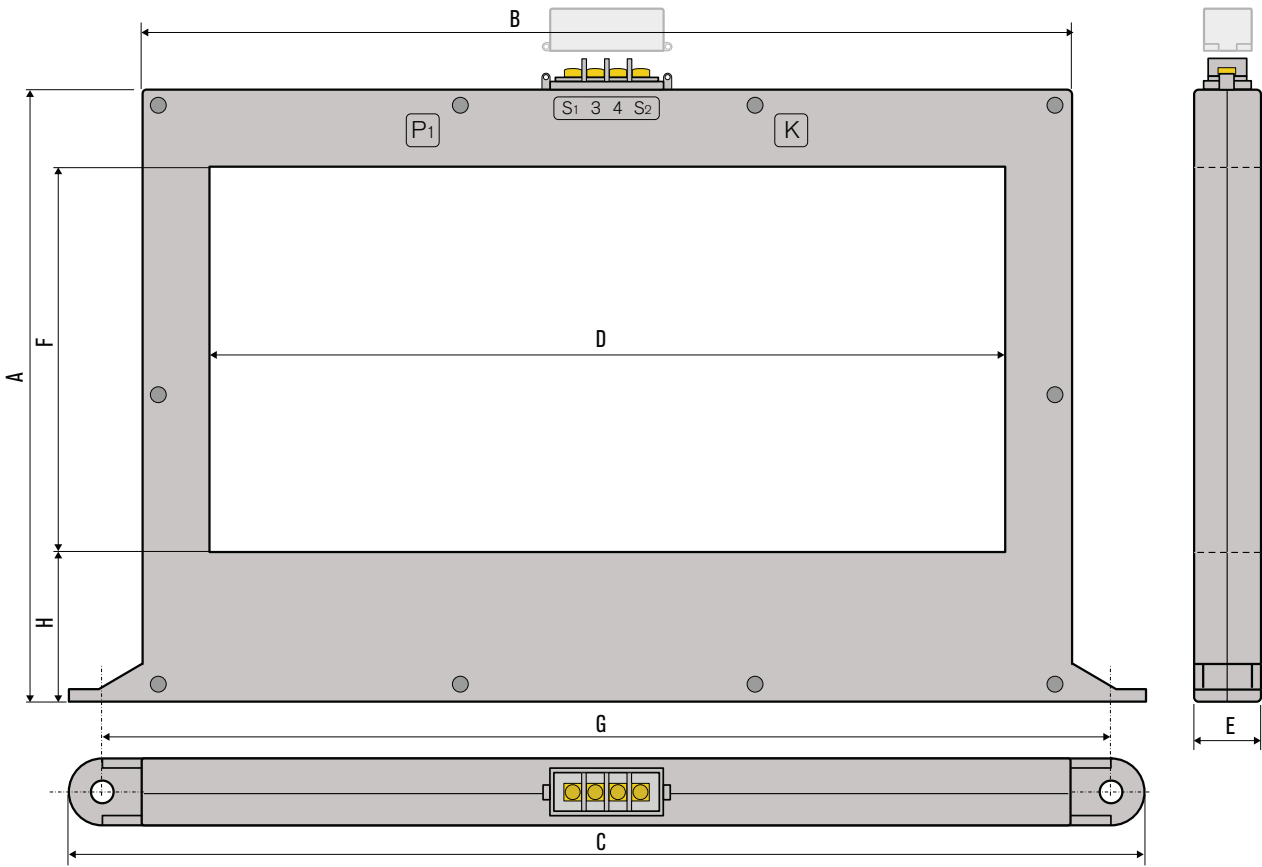

TYPE - DIMENSIONS (mm)	A	B	C	D	E	F	G	H
CT-1/280R	223	338	404	281	28	156	370	29
CT-1/350R	270	410	475	351	28	170	463	66
CT-1/415R	240	497	500	400	50	150	400	-

CT CTD CTA TECHNICAL CHARACTERISTICS	CT-1/22	CT-1/35	CT-1/60	CT-1/80	CT-1/110	CT-1/160	CT-1/210	CT-1/300	CTD-1/28	CTA-1/110	CTA-1/160	CTA-1/210	CTA-1/300	CT-1/280R	CT-1/350R	CT-1/415R
MINIMUM MEASURED CURRENT	25 mA	25 mA	25 mA	100 mA	250 mA	250 mA	250 mA	500 mA	25 mA	250 mA	500 mA	500 mA	1 A	500 mA	500 mA	250 mA
APPLICATION	Connected with earth leakage ELR serie															
OPERATING TEMPERATURE	-10 ÷ 70°C															
STORAGE TEMPERATURE	-20 ÷ 80°C															
TRANSFORMATION RATIO	500/1															
INSULATION TEST	2,5kV for 1 minute															
PERMANENT OVERLOAD	1000 A															
THERMAL OVERLOAD	40kA for 1 second															
TYPE OF TERMINALS	screws with maximum cross section 2,5mm ²															
DEGREE OF PROTECTION	IP20															
REFERENCE STANDARDS	CEI-EN 50081-2, CEI-EN50082-2, CEI 41.1, CEI-EN 60255, IEC/EN 60947-2 "ANNEX M"															

CT-1M EXTERNAL MULTIPLIER TOROIDAL

Toroidal multiplier to extend the current calibration of differential relays up to 250 A.

To connect between toroid and relay.

Reduces the current 10 times. Therefore, the range of the tripping set-point $I_{\Delta n}$ adjustment is multiplied by 10.

CONNECTIONS

Input terminals 5-6 of the multiplier must be connected respectively to terminals 1-2 of the toroid transformer on the controlled line.

N.B. No cables must pass through the external multiplier.

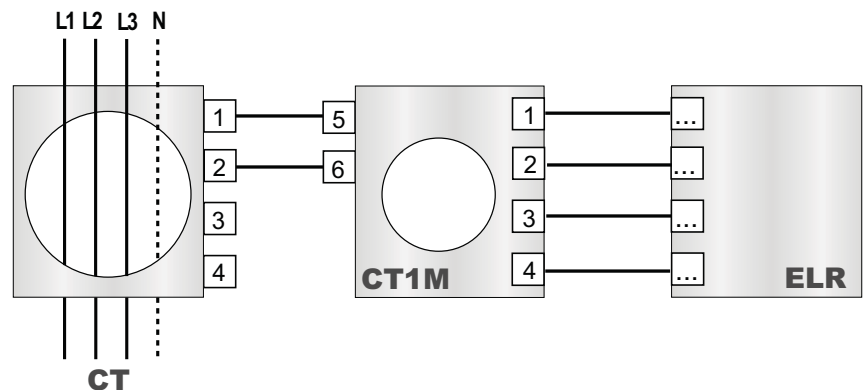

CT-1S EXTERNAL ADDER TOROIDAL

Toroidal adder to be used in cases where the conductors of the system to be protected exceed the inside diameter of the reducer.

In this case they are used CT /5A to be installed in line, which will be then connected to the toroid adder and from there to the differential.

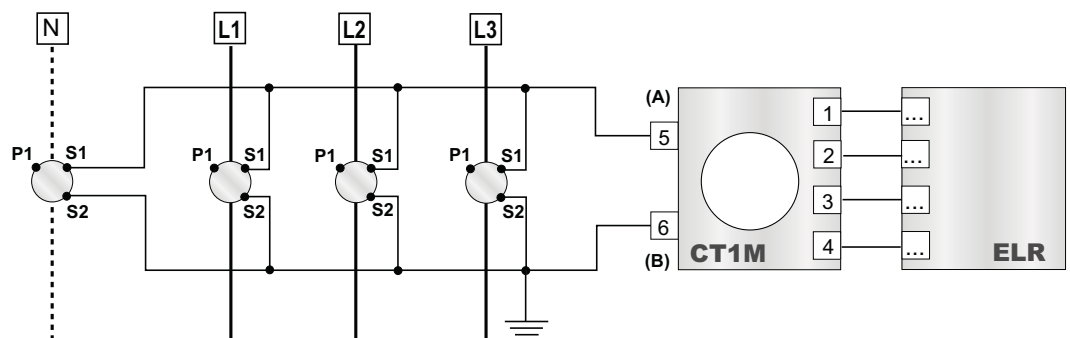

1. APPLICATION THROUGH CT

1.1. APPLICATION - This application is particularly useful in those cases, in which it is impossible to embrace all conductors (supply bars) of the system, with only one transformer. In this case, It is possible to have Earth Leakage Protection, by using Ct's and one of our special toroid transformers (exclusively made by us, based on the winding rate of the Ct's), complying with the wiring diagram, described below.

For this application the Ct's should have: the same transformation ratio (5A secondary), same power (10 VA at least) and class 0,5.

On the other hand, it is important that the Ct's are mounted, in such a way that the script P1 is orientated upstream, towards the line to be protected, and the various secondaries exactly as per the diagram.

2. OPERATING - When there is no earth leakage, the vectorial addition of the currents sensed by the Ct's, is equal to zero. Thence, there is no current flowing in the windings related to our terminals 5 and 6 (in our special toroid). There isn't any voltage generated in our terminals 1 and 2 therefore, which should make the ELR to trip.

When there is a leakage, otherwise, the vectorial addition of the currents sensed by the Ct's is different to zero.

Thence, a voltage is generated through the terminals 1 and 2, making the ELR to trip. For this application, it is advisable to have a tripping threshold of the ELR, not lower than a 1/100 of the rated current of the system to be protected.

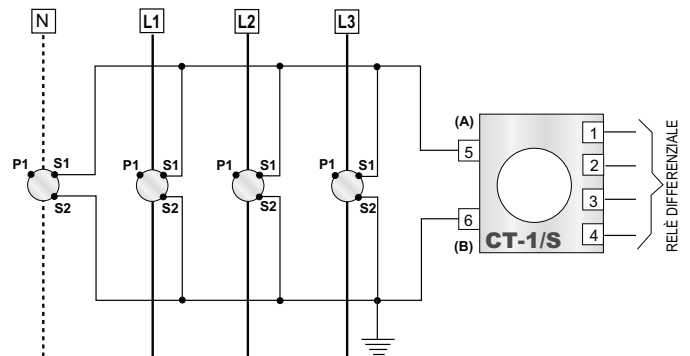

2. APPLICATION WITH TRANSFORMERS GROUND

2.1. APPLICATION - This application is particularly indicated when the system is supplied through Transformers, working in parallel. In fact, it could be impossible to protect the line with ELR's sited immediately downstream of the transformers. Since it wouldn't be possible to establish which part of the Current Leakage to Ground (clg) is borne by one or the other transformer. This brings us to a point, in which is practically impossible to establish exactly the threshold of the tripping value of the relays.

EXAMPLE: Suppose that we wish to protect an installation, which requires that the ELR should trip when the clg is equal to 5A. Should we install 2 ELR's with 5A threshold, it would certainly be required a higher value of clg, in order to make the ELR to trip. On top of the above, in case of an equal distribution of the current leakage between both transformers, it should be required a clg = 10A, in order to make the ELR's to trip. Otherwise, if we adjust the tripping threshold to 2,5A, it could be the case that one transformer is bearing fl of the clg and the other/only. Thence the ELR of the first transformer would trip before the 5A of clg are reached. Other factor to be considered,

is the eventual separation of a transformer from the parallel, during low load demand periods. In this case the eventual clg is totally re-closed through the earth of a unique transformer and the tripping threshold should be establish exactly as 5A, under these conditions. The solution of the problem is given in our diagram.

2.2. OPERATING - Our diagram here below shows the solution, based in connecting the star centres of both transformers together to earth with a unique wire, which has passed through our toroidal transformer before.

It is based in the fact that any current leakage to ground can't be re-closed but through the star centres of the transformers. With the toroidal, positioned as per our diagram, it is measured therefore the total current leakage to ground.

Back to the above mentioned example, we should establish as 5A the tripping threshold value, with the assurance that the ELR will trip, when the clg goes above the 5A threshold.

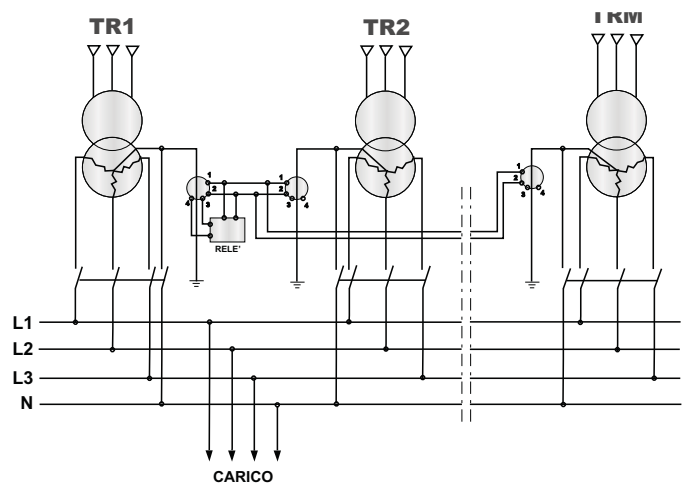
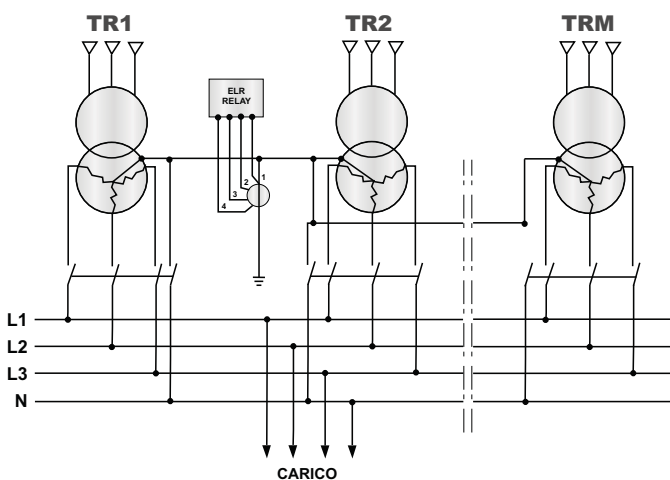

CT-1 / APPLICATION NOTE

TOROIDAL CURRENT TRANSFORMERS

3. APPLICATION ON VARIOUS LINES IN PARALLEL

3.1. APPLICATION - This application can be used whenever there are various connecting lines through two bar systems OMNIBUS.

In this case, the use of ELR's with their corresponding T/T's ,per each connecting line, it could give operation inconveniences; since the vectorial addition of the currents, on each connecting line, might not necessarily be equal to zero.

It could be the case that, with 2 perfectly equal lines, there could be a difference of current distribution, due to a contact resistance difference (in phase R, for example), whilst the adsorbed current by the load might be equally distributed, in the other lines. All this brings along that, there might be a leakage signal, at the toroidals terminals 1-2, which could be sufficient to make the ELR's to trip, without any earth leakage. With this kind of distribution, it is advisable to go to the wiring diagram, in which there are used as many T/T's as connecting lines, all of them orientated towards the 1 and 2 terminals of our ELR.

3.2. OPERATING - when there is no leakage, although with a non uniform current distribution, as mentioned in the above paragraph 3.1, the originated signal at the first toroidal, is totally void by the leakage signal originated at the second toroidal, since the signal can't be but in opposition, and the ELR's terminals won't receive any signal and the ELR won't trip therefore.

Otherwise, when there is an earth leakage, independently of whatever it might be the current distribution, the signals summation, being measured by the various Tt's, meet at the 1 and 2 terminals of the ELR, which will trip therefore.

This application is valid for a maximum of 6 Tt's connected in parallel.

In those cases, in which a higher number might be required,, it is advised to contact us. For this application, it is advisable to have a tripping threshold not below 1/1000 of the nominal current of the system to be protected.

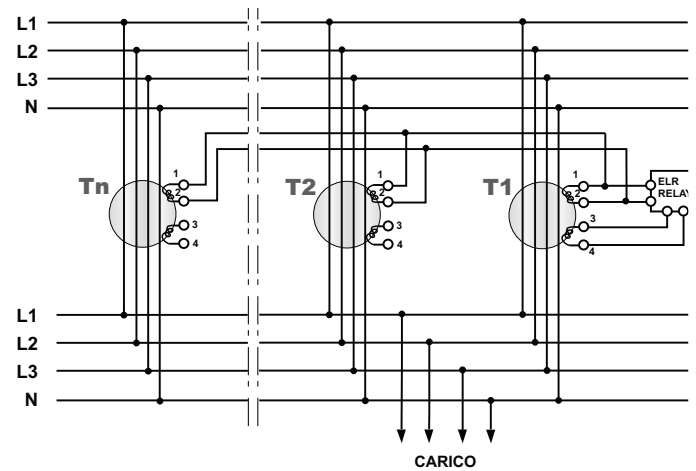

4. MEDIUM VOLTAGE LINES

Should an ELR be used in MV lines, it is advisable to use the built-in filter for third harmonic version.

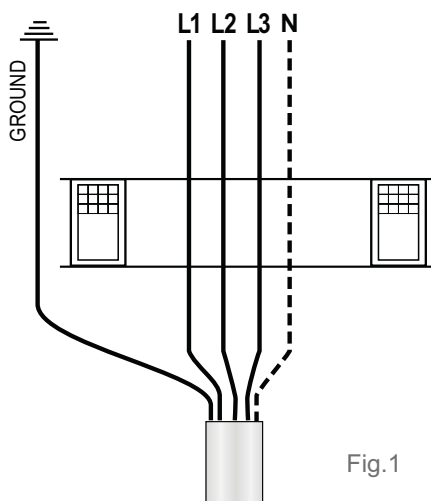

Fig.1

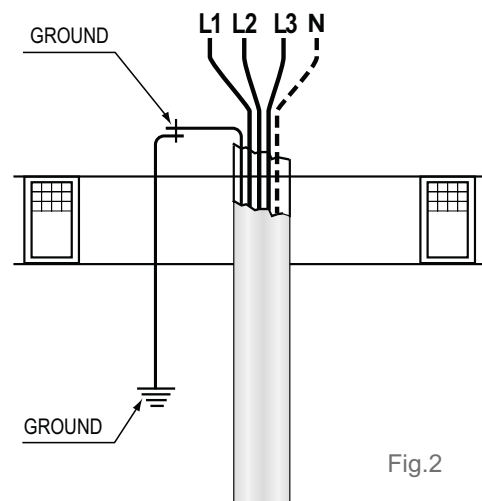

Fig.2

NOTE If there is an earthing circuit, it should be placed outside of the T/T (fig1).

When the cable is fitted with a metallic screen and it gets through the T/T, the earthing connection should be as (fig. 2).