

SOLIDSVAC®

SOLIDS PUMPING SYSTEMS



SV440-CVCD Operations Manual



U1/ 5-7 Boeing Place - Caboolture - QLD 4510 - Australia

+61 456 000 665 / info@solidsvac.com / www.solidsvac.com

CONTENTS

Description	Page
Safety First	3
1. Operation Overview	3
2. Design Registration	3
3. Technical Data	4
4. Schematic	5
5. Pump Set-Up	7
6. Operation, Timer Cycling & Adjustments	8
7. Maintenance	9
8. Accessories	13
9. Operation Risk Assessment	14
10. Spare Parts	22
11. Job Safety Analysis	30



Scan this QR Code for an electronic version of this Operations Manual

SAFETY FIRST

CAUTION & GENERAL SAFETY

This manual contains important information concerning the installation, operation and maintenance of the Solidsvac Pump, Model SV440-CVCD. To prevent injury to personnel or equipment damage, this manual MUST be read and understood by those responsible for the installation, operation and maintenance of the equipment.

THIS OPERATION MANUAL MUST BE USED IN CONJUNCTION WITH BOTH SITE-SPECIFIC RA AND JSA'S.

- Isolate, tag out and disconnect the air supply to the unit prior to working on any part of the system
- Lift the equipment only at the lifting points provided
- The pump should be installed in a safe level area, which provides adequate access for operating the equipment
- Ensure all hoses are in good condition, correctly rated and certified for the service in which they are to be used
- Inspect the unit regularly for damaged or worn components
- All covers MUST be fitted prior and during operation
- Air pressure should NEVER exceed rated pressure
- Tie down points (if fitted) MUST NOT be used as lifting point

CAUTION: BE AWARE OF RETAINED MATERIAL IN THE TANK INCREASING WEIGHT

SOLIDSVAC PUMPS EACH HAVE SPECIFIC COMPRESSED AIR REQUIREMENTS DEPENDING ON THE JET PACK FITTED.

The operator MUST ensure that an appropriate and adequate air supply is available depending on the model and Jetpack in use.

All Solidsvac equipment require a minimum operating pressure of 689kPa and have a maximum operating pressure of 758kPa (110psi). The recommended size for the air supply hose is dependent on the Jetpack configuration, below is a guide for each.

50-230CFM – 1"

380-600CFM – 2"

900-1200CFM – 3"

Note: An 18mm (¾") i.d. Air hose contains HALF the volume of the recommended 25mm (1") hose.

The Discharge hose MUST be no smaller in diameter than the pumps outlet, preferably a self-supporting type and secured at regular intervals.

1. OPERATIONAL OVERVIEW

The Solidsvac range is a compressed air driven and controlled pumping system which utilises a compressed air venturi to vacuum and convey material through a pressure vessel (AS1210). This is achieved with a range of airflows from 50 CFM (84.95m³/hr)- 1200 CFM (2038.8m³/hr) @ 100psi (6.89bar). During the suction phase the venturi creates vacuum that allows any flowable material with solids ranging up to 75mm to be drawn into the vessel. Then during the discharge phase, compressed air is exerted into the vessel and the material, is pressure discharged. These 2 phases are repeated to allow the pump to convey material, with the duration of each phase being controlled by timers.

With the Solidsvac range of Constant Vacuum/ Constant Discharge units (CVCD) a dual system unit is utilised, with one system having a vacuum exerted on it whilst the second has pressure exerted on it. This results in a near continuous flow of material at both ports.

A Solidsvac Vac-Pack uses a compressed air powered venturi system to only generate a vacuum. The Vac-Pack can turn any appropriately rated container into a recovery vessel.

WARNING

Compressed air can be dangerous. Correctly rated hoses and piping should be used in conjunction with the appropriate fittings and safety devices on all connections.

The unit is not designed to operate above 758kPa (114psi) and the PRV will relieve at 758 +/- 35kPa (110psi +/- 5psi).

3. TECHNICAL DATA

TECHNICAL DATA	METRIC	US IMPERIAL
Height	1600 mm	63"
Width	1270 mm	50"
Length	2010 mm	79"
Weight	950 kg	2094 lb
Air inlet	50 mm	2" BSP/NPT
Suction inlet	100 mm	4"
Discharge outlet	100 mm	4"
Suction lift	11.5 m @ 330 cfm 25m @ 380 cfm 35m @ 600 cfm	37' 7" @ 330 cfm 57' @ 380 cfm 88' @ 600 cfm
Air consumption options	6.5m ³ /Min JetPack & 2.8 m ³ /Min Discharge 10.7 m ³ /Min Jetpack & 5.6 m ³ /Min Discharge 16.9 m ³ /Min Jetpack & 5.6 m ³ /Min Discharge	230cfm Jetpack & 100cfm Discharge 380 cfm Jetpack & 180 cfm Discharge 600 cfm Jetpack & 180 cfm Discharge
Delivery	500+ m	1640+ ft
Displacement cycle	420 ltr	34 gal
Operating pressure	7 bar (Required) @ 690 kPa	100 psi (Required)
Unit Requirements	15.8 m ³ /Min or 22.1 m ³ /Min	560 cfm or 780 cfm
Maximum solids	80 mm	3"
Water throughput	1000 lpm (380 cfm)	264 gpm (380 cfm)

4. SV440-CVCD SCHEMATIC

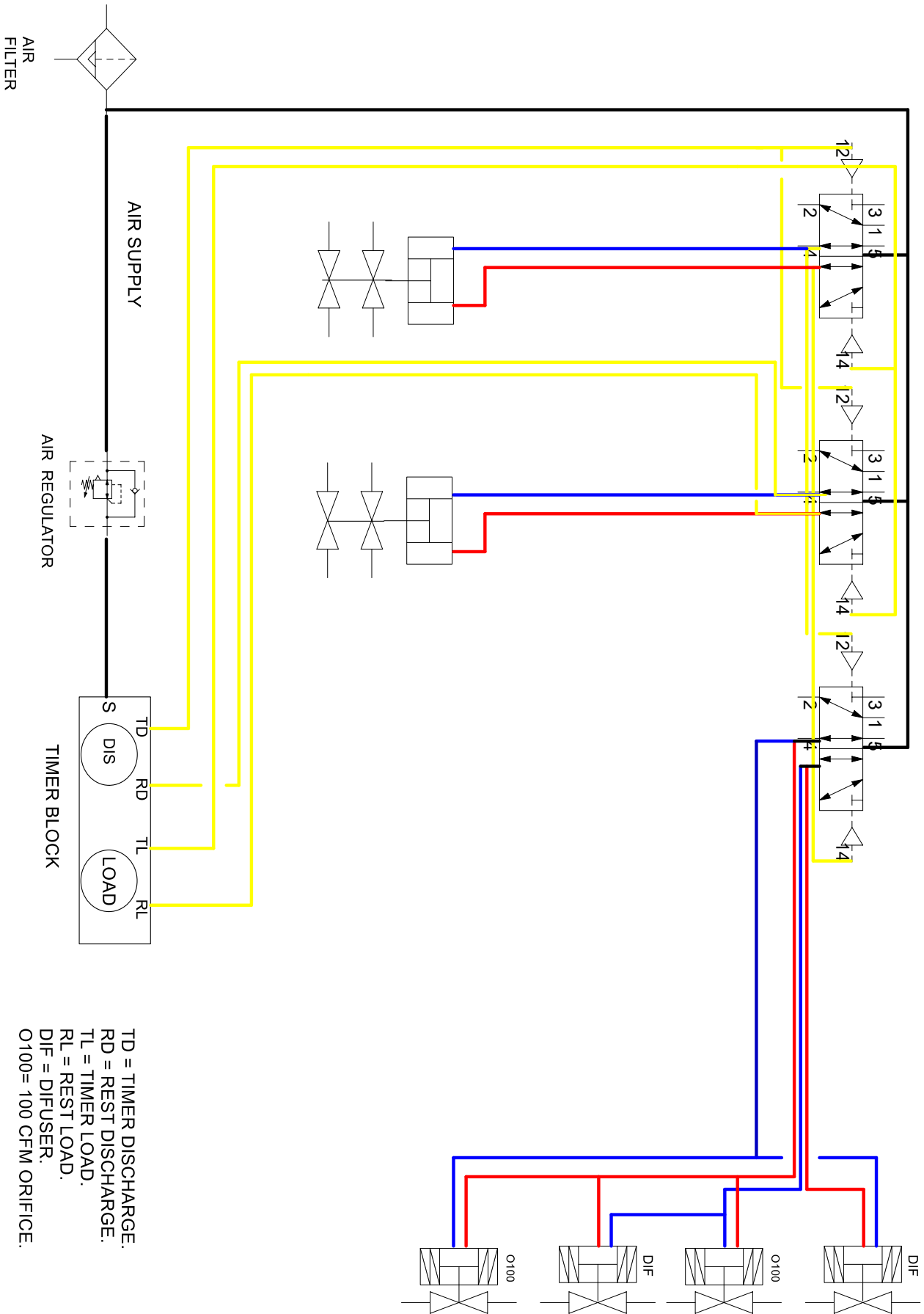

SV440 CONTROL AIR AND DRAIN

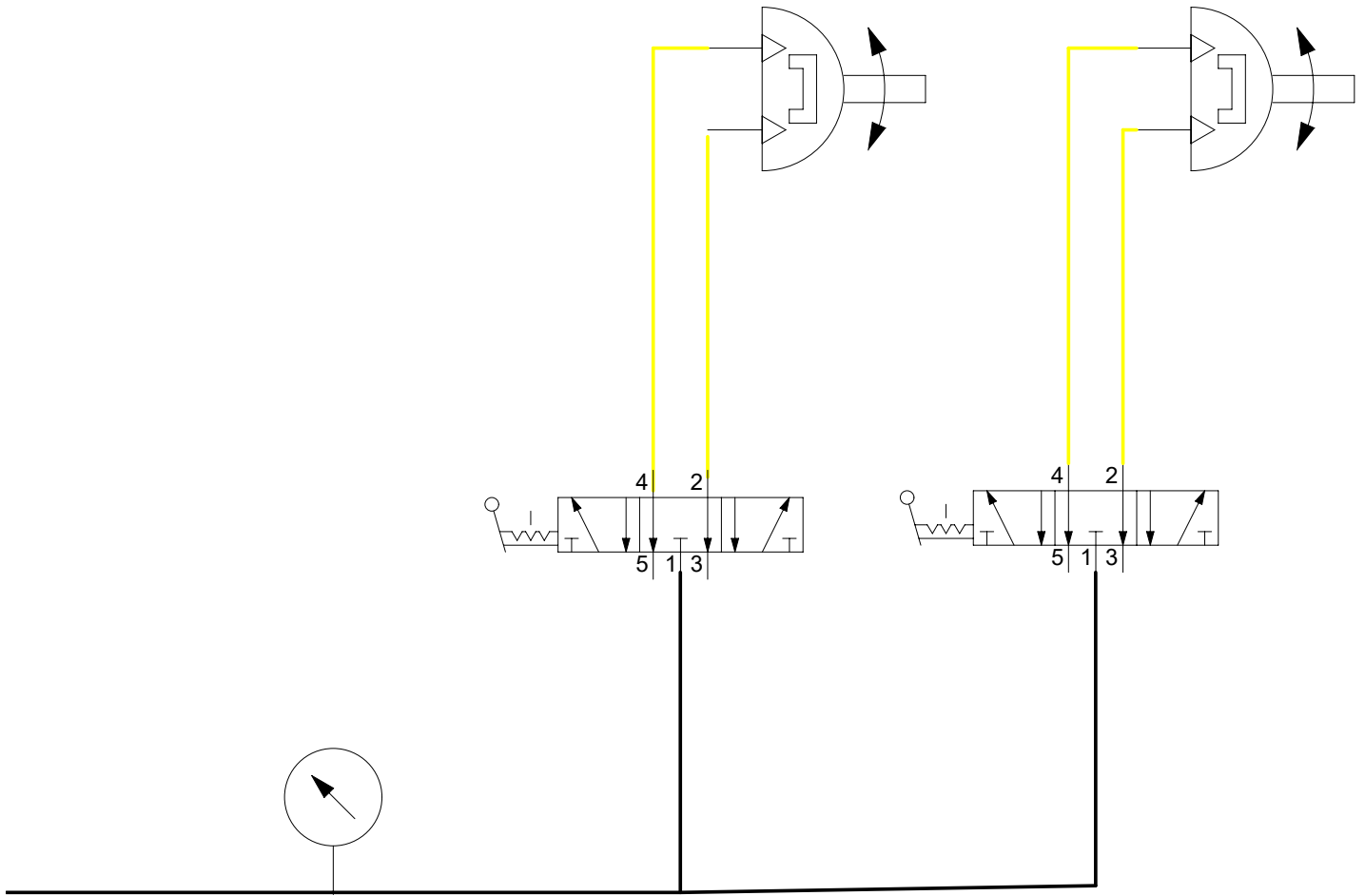

4. DESIGN REGISTRATION

The Solidsvac SV440-CVCD has a Certificate of Plant Design Registration from Workcover NSW, Australia. A copy of which may be obtained by contacting Solidsvac Pumps.

DESIGN REGISTRATION # PV-6-204612/16

TECHNICAL STANDARDS

- AS2971-2007 Serially Produced Pressure Vessels
- AS4343-2005 Pressure Equipment - Hazard Levels
- AS1210-1210 Pressure Vessels
- ISO 80079-36:2016
- ISO 80079-37:2016
- ISO 80079-38:2016
- IEC 60079-0:2017

The requirements of ISO 80079-36 and IEC 60079-0 have been applied to this equipment.

Temperatures are continuously rated and deterioration of the equipment during use will not compromise the Ex properties.

An ignition hazard assessment has been performed in accordance with ISO 80079-36.

Certificate: IECEx ExTC 24.0008X

Code: Ex h I Ma (0 °C ≤ Tamb ≤ +50 °C)

Ex h IIB T4 Gb (0 °C ≤ Tamb ≤ +50 °C)

CONTENTS EXCLUDED FOR PUMPING

Solidsvac recommends that any contents that fall within the scope of the below class liquids should not be pumped with any Solidsvac unit. Solidsvac also recommends that a site-specific JSA should be conducted with reference to any other type of material being pumped.

- Class IIIA liquids with a flash point equal to or greater than 140 °F (60 °C), but less than 200 °F (93 °C) have a NFPA 704 flammability rating of 2.
- Class IIIB liquids with a flash point equal to or greater than 200 °F (93 °C) have a NFPA 704 flammability rating of 1.

OPERATING PARAMETERS

The Solidsvac SV440-CVCD can operate within environments ranging from 0 °C to 50 °C and all humidity.

The maximum medium temperature allowable for the SV440-CVCD is 50 °C.

HOSES

Solidsvac recommends the hoses (Air Supply, Suction, Discharge) used in operation with the Solidsvac Pumps are to be made of anti-static material to ISO 6805:2020.

EARTHING POINT

All Solidsvac models are fitted with an Earthing Point which is mandatory requirement prior to operation. Solidsvac strongly recommends that the operator takes the necessary measures to earth the unit prior to operation.

CONDITION OF USE

It is a condition of use that the equipment is to be earthed according to the user manual prior to operation.

It is a condition of use that the equipment is to be supplied compressed air from a clean source.

WARNING:

**TO AVOID POSSIBLE ELECTROSTATIC CHARGES PRODUCED BY THE MATERIAL CONVEYED
THE OPERATOR MUST EARTH THE UNIT PRIOR TO OPERATION**

5. PUMP SET-UP

Before commencing operation, Solidsvac strongly recommends each user reads and understands the Operation Manual supplied with each unit and available online or via the QR code on each pump.

Note: Minimum training is required to operate the SV440-CVCD however, it is essential for the safe operation of this equipment that the Operator has read and understands the SV440-CVCD Operation Manual.

Solidsvac also recommends that a site-specific Risk Assessment (RA) and Job Safety Analysis (JSA) be undertaken prior to the commencement of any works involving the Solidsvac.

Any recommendations arising from these should be considered additional to these:

- The unit and all hoses and fittings are in good working order and fit for purpose.
- The source of compressed air is sufficient in both volume and pressure.
- The correctly rated compressed air supply hose is used (50mm or 2" ID)
- All equipment covers are correctly fitted and properly secured.
- The Discharge Hose is adequately secured to prevent "hose whip".
- The Discharge Area has both barriers and signage in place to protect personnel.
- The Discharge Area has suitable warnings to protect personnel.
- The correct PPE is available and worn by the operator
 - Eye Protection
 - Hearing Protection
 - Gloves
 - Safety Boots
- Set the Solidsvac Pump in a safe level location as close to the material to be pumped as possible.
- Attach both suction and discharge hoses along with any accessories as required and ensure safety clips are in place.
- If pumping material for any distance over 30 M (100') Solidsvac highly recommend the installation of a "T" valve arrangement in the discharge line as it exits the pump to enable the dumping of residual pressure in the event of a discharge hose blockage
- Ensure the main air valve is in the off position and install a "T" valve arrangement at either the source or the pump to enable pressure in the supply line to be dumped at the end of operations, fit safety clips as required.
- Ensure frame is adequately earthed.
- The pump is now ready for use.

6. OPERATION

With the Suction hose out of the material to be conveyed, turn the pumps Main Air Supply Valve "ON". The pump will commence operation.

Note: Dry operation will not damage the pump.

With the system energized and the unit cycling, check both pneumatic gauges and ensure the correct pressure is available to commence operations. The Primary Gauge indicates the working pressure and should indicate approximately 7 Bar, or 100psi is available. The smaller Secondary Gauge indicates control system pressure and MUST always remain above 5.8 Bar or 85psi, when operating.

LOAD TIMERS

The Load and Discharge cycles are controlled by adjustable 0-30 Sec pneumatic timers located within the control box. Due to the continuous system of the SV440-CVCD the pneumatic timers MUST be set at an equal setting (i.e., 5/5 or 10/10 etc). The load cycle will determine the overall setting for the timers, therefore if optimal load time is 5 seconds, then discharge time will automatically be set to 5 seconds.

Solidsvac recommend that the operator allows the pump to cycle twice prior to transferring material to ensure all aspects of the pump set-up are functioning correctly and safely. It is advisable to introduce the Suction Wand (if fitted) or Suction Hose to the material to be conveyed for an initial single cycle and observe that all aspects of the pump set-up are functioning correctly and safely. If no adjustments are required, commence continuous pumping operations.

IMPORTANT: TIMERS ARE REQUIRED TO BE ADJUSTED TOGETHER EQUALLY.

PNEUMATIC GAUGE CONTROLS

The SV440-CVCD is fitted with 2 pneumatic pressure gauges to ensure the operator has a correct reading of control and operational air pressure. A small, mounted gauge ON the control box will display the regulated air for all controls running at 586kPa (85psi).

The second pressure gauge is mounted on the exterior of the control box and displays the working pressure of the pump. This gauge will only show the operational air pressure at the pump, this is not to be assumed as the pressure output of the compressor. Solidsvac recommend checking the compressor's gauge to obtain a reading.



**CONTROL BOX
NEUTRAL POSITION**



**CONTROL BOX
OFF POSITION**



**CONTROL BOX
ON POSITION**

7. MAINTENANCE

The Solidsvac SV440-CVCD generally require a minimum of maintenance although Solidsvac recommend the following be adhered to as a minimum:

DAILY:

- Check that all fittings and connection are serviceable.

WEEKLY:

- The unit's auto drain filter be inspected and cleaned as required.
- The exhaust box be inspected and cleared of any carry over material.

MONTHLY:

- Carry out both the daily and weekly maintenance requirements.
- Using "service air only", and with NO HANDS WITHIN THE UNITS VALVE ARRANGEMENT cycle the unit and carry out a visual inspection of the valve linkages.
- In very harsh environments, a spray of CRC penetrant or similar is recommended.

SERVICE AIR:

- It is recommended that only service air is used when performing maintenance on the pump.
(That is air plugged in to the pneumatics not through the air manifold or venturi.)

A service air connector will be provided with any unit service KIT and upon request.



MAIN AIR FILTER

The main air filter is located against the control box and is self-draining, however it should be inspected weekly.

EXHAUST BOX

All CVCD variants are fitted with an exhaust box located in the front of the unit. The exhaust box can be accessed for cleaning by removing the top lid. Hosing the exhaust box will ensure debris is free from blocking the exit vent. Blocking of the exit vent and exhaust box in general will reduce vacuum performance.

The SV440-CVCD is fitted with 316 stainless steel deflector plates to improve pumping efficiency. Solidsvac recommends to inspect and clean the exhaust box assembly after each job.

All CVCD variants are fitted with a drain valve located underneath the exhaust box. The drain valve can be operated on the control box (see page 8.)

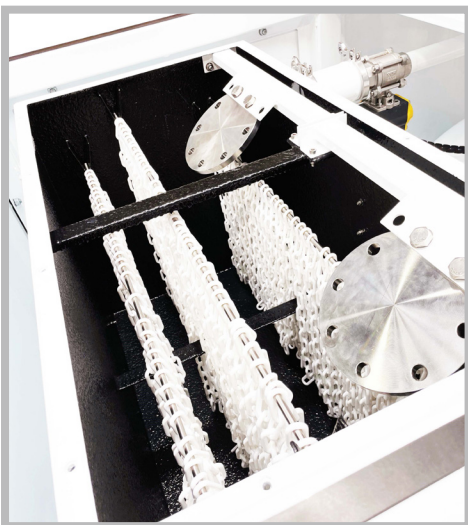

**EXHAUST BOX
DEFLECTOR PLATES**

**EXHAUST BOX
DRAIN LOCATION**

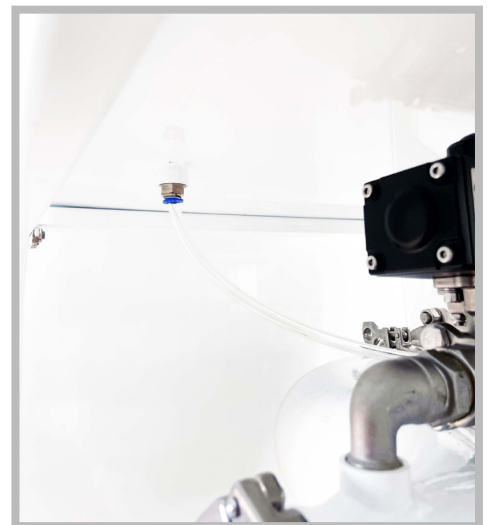

MAINTENANCE CONTINUED...

In use, the Solidsvac SV440-CVCD requires little to no maintenance, however Solidsvac recommends that the following strict measures are taken to ensure the pump remains in good working order.

Maintenance, repairs and the disassembling of the unit be carried out by any authorised personnel.

SERVICE TIPS

- Set up a maintenance schedule and follow it diligently.
- Clean the machine areas before removing pneumatic components.
Note: When steam cleaning or using water to clean a machine, be sure that filler openings, breather caps etc are protected from possible entry of water into the system.
- Use clean plastic plugs to cover the ends of disconnected lines or to plug openings when working on a pneumatic system.
- A clean workbench is an absolute 'MUST' when servicing components. An industrial-type vacuum cleaner is a valuable aid in removing dust, dirt and tiny metal particles from the work area.
- Check the condition of your tools – they should be clean. Always use hammers made of plastic or leather, so there is no danger of metal chips getting into components.
- When removing parts for service, clean them and then store them in plastic bags or other clean containers until they are installed again.
- When cleaning pneumatic parts, use extreme care to ensure that the cleaning fluid is non-flammable and compatible with the system.
- Use common-sense precautions to prevent dirt entering components that have been temporarily removed from the circuit.

SYSTEM PERFORMANCE

Pneumatic problems that affect system flow and pressure are not always easy to locate. The system testing procedure described later in this section is based on a useful step-by-step approach to troubleshooting. Troubleshooting charts make the fault-finding process easier and faster.

EFFECTS OF A DROP IN SYSTEM FLOW RATE

- A pressure drop will affect the speed and cycle times of a pneumatic machine; actuators will not extend, retract, or rotate at the required speed. Actuator control will become jerky with inconsistencies in flow as cylinders and motors are supplied at different rates. In many complex pneumatic systems, the sequencing and positioning of component operations will be affected as cycle times become thrown out of programmed control.
- The compressor's discharge flow rate should be checked first to ensure that the drop in flow is not a problem of internal leakage or incorrect setting of compressor controls.

EFFECTS OF DROPS IN PRESSURE

The major causes of pressure drop include:

- Pipework restrictions (for example, incorrect sizing) fitting restrictions and sharp corners
- Incorrect pressure settings
- Sudden enlargement in fluid conductors
- Long lengths of fluid conductors
- Component leakage (internal and external)
- Broken valve springs
- Blocked or crimped air lines
- Loose fittings
- Valves not sealing correctly because of contaminants
- Some combination of the above causes

SYSTEM TESTING PROCEDURES

Pneumatic systems, like all machines, require routine maintenance to ensure reliability. However, there are still times when problems occur and **MUST** be located quickly and efficiently, especially in production applications. A step-by-step method has been devised as a way of finding and solving pneumatic problems quickly.

These steps are as follows:

STEP 1: KNOW THE SYSTEM –

Study the machine's technical specifications to obtain an understanding of how the system operates and the function of the machine's components. Obtain a circuit drawing and check the system through. Check the machine's maintenance records and commissioning test results if they are available.

STEP 2: ASK THE OPERATOR –

Determine the symptoms of the problem by asking the operator for a detailed description of the machine's normal operating performance.

STEP 3: INSPECT THE MACHINE –

Use your senses (touch, smell, sight and hearing) to locate problems or damage such as noisy components, air leaks, malfunctioning components and damaged air lines.

STEP 4: OPERATE THE MACHINE –

Operate the machine and check that the machine's gauges are reading "NORMAL" and that there are no unusual noises. The operation of the machine's controls should not be 'sticky' or 'spongy'. The machine's performance should not be slow, erratic – nor non-existent.

STEP 5: LIST THE POSSIBLE CAUSES –

Once the fault has been located and recognised, list the possible causes – starting with the simplest.

STEP 6: REACH A CONCLUSION –

Use a troubleshooting chart to check the list of possible causes; then decide which is the most likely.

Note: 99% of all issues are air supply related.

SAFETY FIRST

**THE SV440-CVCD MUST BE ISOLATED FROM ITS AIR SUPPLY AND TESTED DEAD PRIOR TO ANY MAINTENANCE WORK BEING UNDERTAKEN.
FAILURE TO DO SO COULD RESULT IN SERIOUS INJURY OR DEATH.**

SYSTEM MAINTENANCE

A pneumatic system is easy to maintain. However, like any other mechanism, it MUST be operated and maintained correctly. Pneumatic systems can be damaged by excessive pressures, fluid contamination and by high operating temperatures.

Regular maintenance will reduce your pneumatic troubles. By using a regular maintenance programme (preventative maintenance) to care for a system, you can eliminate common problems and anticipate special ones. Problems can be corrected or averted before a breakdown occurs.

The following are the key problems that commonly need to be addressed in pneumatic maintenance:

- Water-contaminated air
- Poor air filtration
- Incorrect pressure settings
- High air temperature
- Loose supply lines
- Faulty seals

IMPORTANCE OF CLEANLINESS

Cleanliness is of supreme importance when it comes to servicing pneumatic systems. Keep dirt and other contaminants out of the system. Small particles can score valves, cause seizing of components and clog orifices, resulting in expensive repair jobs.

When servicing a pneumatic system, always do the following to ensure cleanliness:

- Keep the compressor and machine's lubricating oil clean
- Keep the system clean
- Keep your work area clean
- Be careful when you change seal or components (take photos)
- Use caution with compressed air
- Ensure all pneumatic components supply lines are secure

8. ACCESSORIES

Suction Wand – Attaches to the suction hose allowing the operator to stand upright and ambient air to be introduced at the material inlet.

Strainer – Available in a wide range of sizes and attaches to the suction hose to prevent the ingestion of oversize particles.

VacHead – An industrial vacuum head with squeegee brush allows the operator to stand upright, recovering material from hard surfaces i.e. an oil spill from a road surface.

Note: It is recommended that the suction timing cycle is set long when using this accessory.

Delivery Carousel – Controlled discharge to either a conveyor or multiple points/skids etc.

Hoses – A complete range of high quality suction and discharge hoses are available.

Hoover Head – Helps focus the vacuum and is ideal for recovering heavier material such as barite, oil sludge, mud or similar from tank bottoms and various hard surfaces.

Dropbox – Delivery of material to a skip, conveyor or specific point.

Service Kit – Contains all you need for basic maintenance on your pump.





OPERATIONAL RISK ASSESSMENT

OBJECTIVE:

The objective of the hazard identification and risk review process is to ensure all hazards are identified and accurately assessed for risk. Suitable and effective controls MUST be nominated and implemented to keep workplace safe.

CONTEXT:

The Solidsvac SV440-CVCD Solids Pump is designed to be used in a coal mine for the purposes of pumping slurry/fluids. The Solidsvac SV440-CVCD Solids Pump will be in a stationary position on the floor. The floor conditions need to be safe and level.

SCOPE:

The Scope of the risk assessment as follows:

- 1) Identify operational hazards associated with the use of the Solidsvac SV440-CVCD Solids Pump
- 2) Risk Assess each of the identified hazards
- 3) Implement controls to minimise any hazards to an acceptable level

INVOLVED PERSONS/STAKEHOLDERS:

Risk Facilitator

Solidsvac Management/Tradespeople

ASSUMPTION:

Supplier

Competent, comply with standards and drawings.

End User (Owner/Hirer/User)

The end user has:

- Competent (operators are trained, competent, authorised, etc.)
As per the instructions in the manual all personnel responsible for the installation, operation or maintenance of the equipment MUST read and understand the manual.
- Procedures (change management, traffic rules, risk assessed, developed, effectively implemented, etc.)
- Equipment fit for purpose (rated, designed compatible, maintained, inspected, monitored, etc.)
- Leadership (communication, directions, monitoring, etc.)
- Environmental conditions are compatible to the operational capabilities of the equipment (natural vs. man-made, etc.)

INCLUSIONS:

Only the aspects directly related to Solidsvac SV440-CVCD Solids Pump.

EXCLUSIONS:

Transporting and storing the Solidsvac SV440-CVCD Solids Pump (Users operational risk assessment, training, competence);

Assessment of the environmental conditions in the operational area (Users planning and local risk control)

REFERENCE MATERIAL:

QLD Coal Mining Safety & Health Act 1999

QLD Coal Mining Safety & Health Reg 2001

Recognised Standard 02 Control of Risk Management Practices

RISK MATRIX

Step 1: Establish the Consequence (1-5)

Consequences		Injury / Occupational Illness or Disease (How to manage Work Health and Safety Risk – Code of Practice, Safety Work Australia 10 August 2011). The company must ensure levels of consequence and likelihood are relevant to the company's Business risk.	Business Loss/Asset Damage	Reputation/Social/Community	Legal and Regulatory/Contract	Environmental Impact (e.g. Hydrocarbon spills)
1	Insignificant	Report only	<\$5k	Complaint/ Single project or stakeholder	Minor non-compliance - internal report only	Negligible pollution
2	Minor	First Aid Treatment Injury/illness Non-prescription medication/treatment that can be administered by first aider.	<\$20k	Local public concern	Minor legal non-compliance - Contractual issue	Minor pollution/ Nuisance
3	Moderate	Medical Treatment Injury/illness Prescription medication/treatment that can only be administered by a registered doctor/nurse. Minor LTI <5 full days work lost	<\$50k	Regional public concern/Multiple stakeholders	Serious breach of law/Investigation by authority/ On the spot fine. Major breach of contract.	Noticeable pollution
4	Serious	Serious Lost Time Injury/illness Loss of 5 or more days work/admission to hospital/ serious injury under WHSA definition	<\$100k	National public concern	Significant penalties/ Termination of contract	Significant environmental event
5	Major	Fatality Single or multiple fatalities	<\$100k	International public concern	Law suits/ Prosecution/ Removal from suppliers list	Major environmental event/Material environmental harm

Step 2: Establish the Likelihood (A-E)

Description		Frequency Examples (How to manage Work Health and Safety Risk – Code of Practice, Safety Work Australia 10 August 2011).
A	Certain to occur	Expect to occur in most circumstances (>1 event/month)
B	Very likely	Will probably occur in most circumstances (2 to 1 events/year)
C	Possible	Might occur occasionally (1 event/1 to 2 years)
D	Unlikely	Could happen at some time (1 event/2 to 3 years)
E	Rare	May happen only in exceptional circumstances (>3 to 5 years)

Step 3 : The Hierarchy of Risk Control Model			
<p>Start at the top and only if you can't select controls from one section, move to the next one down. You need to use a combination of control measures to achieve the second level of risk control. If a particular hazard can't be removed the risk associated with the hazard can never be eliminated.</p>			
1	Elimination	Complete removal of the hazard	Most effective
2	Substitution	Replacing the material of process with a less hazardous one	
3	Isolation	Separate the hazard from people	
4	Engineering	Guarding, ventilation, design, re-design etc	
5	Administration	Providing controls such as training and procedures	
6	PPE	Use of PPE when other controls are not practical	Least effective
7	Post	Mitigation after an event (all Fire extinguisher)	

Using the Matrix to Determine Risk Score					
Likelihood	Consequences				
	1	2	3	4	5
A Certain to occur	Low 11	Moderate 16	Moderate 20	High 23	High 25
B Very likely	Low 7	Low 12	Moderate 17	High 21	High 24
C Possible	Low 4	Low 8	Moderate 13	High 18	High 22
D Unlikely	Low 2	Low 5	Moderate 9	Moderate 14	High 19
E Rare	Low 1	Low 3	Low 6	Moderate 10	High 15
ALARP - As low as reasonably practical					
Tolerable	Take action to manage ALARP		Intolerable (without specific senior management approval)		

REFERENCE	ACTIVITY	SUB ACTIVITY	HAZARD	RISK EVENT	EXISTING CONTROLS	CURRENT RISK WITH EXISTING CONTROLS			RISK TREATMENT (Accept, Transfer, Avoid, or Further Risk Review)	ADDITIONAL RECOMMENDATIONS	STATUS (Complete, Incomplete, In progress)	Date
						CONSEQUENCE	LIKELIHOOD	RISK RATING				
						OPERATIONAL RISK ASSESSMENT						
10	Transport to work site	Travel position	Inadequate transport method	Resulting in personal injury and damage to the Solidsvac SV440-CVCD Solids Pump during transport	Wheels and handle on the Solidsvac SV440-CVCD Solids Pump Designed well balanced Mine transport rules				Placement and loading of the Solidsvac SV440-CVCD Mobile Fluids Pump to be included in the training and assessment document in the Solidsvac SV440-CVCD Solids Pump	Open		
11	Set up	Environment	Solidsvac SV440-CVCD Solids Pump set up on uneven ground or pump is inadequately secured to rib when on uneven ground resulting in unplanned movement of pump	Resulting in personal injury and damage to the Solidsvac SV440-CVCD Solids Pump during operation	Operation manual and training documents set up procedure on level ground or securing pump to the rib using rated restraining devices when operating on uneven ground	2	C	LB	ALARA	Training and assessment in the Solidsvac SV440-CVCD Solids Pump package		
			Manual handling	Failure of the correct manual handling technique	Manual handling training at induction team lifts where required Most set up and removal tasks conducted from floor level and reasonable height	2	C	LB	ALARA	Training and assessment in the Solidsvac SV440-CVCD Solids Pump package		
			Nip/crush points and "line of fire" issues from mobile equipment, low roof height issues during set up and removal resulting in crush injuries	Resulting in personal injury	Operation manual and training documents setup, removal procedures Operation manual and training documents identify the need to drain pump before disconnecting. Mine transport rules line of sight before any movements No machine movements without positive communications HR-VZ clothing	3	C	M13	ALARA	Training and assessment in the Solidsvac SV440-CVCD Solids Pump package		
			High pressure compressed air	Failure of the compressed air system resulting in: Personal injury from being exposed to compressed air due to hose failure and/or damage	Rated pressure hoses Mine Site Induction and Training Competencies	3	C	M13	ALARA			
			Work on or around a moving belt	Interaction with conveyor resulting in personal injury	Mine Site Induction and Training Competencies	2	C	LB	ALARA			
12	Operation		Discharged material (at 100psi) contacts operators	Resulting in personal injury	Operation manual and training documents the set up procedure incorporates barricading discharge area with caution tape	2	C	LB	ALARA			
			Pinch points on Solidsvac SV440-CVCD Solids Pump during operation	Resulting in personal injury	Fit for purpose covers fitted to pump during operation, MUST be in place	2	C	LB	ALARA			
			Blocked discharge hose resulting in exposure to stored energy while unblocking hose	Resulting in personal injury	Operation manual and training documents unblocking procedure Pressure relief valve at the pump relieves discharge pump pressure	2	C	LB	ALARA			
			Blocked suction hose resulting in process delay	Resulting in personal injury and/or process delay	Operation manual and training documents unblocking procedure Isolation training and procedures Low pressure i.e. 10psi Strainer or nozzle fitted to suction hose	2	C	LB	ALARA			
			Friction generated static discharge	Resulting in personal injury and/or process delay	Fras or bonded housing used for suction, Discharge and Air Supply, far band point installed on equipment, fit for purpose.	2	D	L5	ALARA	OEM recommends a specific Risk Assessment to be conducted to identify friction generated static discharge.		
13	Maintenance		Incorrect maintenance resulting in equipment failure	Resulting in personal injury and/or process delay	Tested to Australian Standards OEM Maintenance scheme	2	C	LB	ALARA	Maintenance to be carried out as per OEM Suppliers SV440-CVCD Operation/Maintenance Manual		

RISK REGISTER ACTION PLAN

No	ITEM/ISSUE	AGREED ACTION	WHO	WHEN	COMP DATE	REVIEW/AUDIT DATE
Operation	Storage	Communicate to end user to develop work procedures for storage of Solidsvac SV440-CVCD Mobile Fluids Pump	Solidsvac	Delivery		
	Travel position	Communicate to end user to develop work procedures for travelling	Solidsvac	Delivery		
	Use of Solidsvac SV440-CVCD Mobile Fluids Pump	Supplier to develop work procedures for operating the Solidsvac SV440-CVCD Solids Pump	Solidsvac	Delivery		
Maintenance	Daily	Supplier to develop daily and/or pre-use visual inspections procedures for using and operating the Solidsvac SV440-CVCD Solids Pump	Solidsvac	Delivery		
	Weekly	Supplier to develop weekly visual, operational, maintenance inspections for using and operating the Solidsvac SV440-CVCD Solids Pump	Solidsvac	Delivery		

PUMP PREVENTATIVE MAINTENANCE PROGRAM

The following is the work to be performed to a SV440-CVCD Pump during Preventative Maintenance Check.

All items, except annual checks (Tradesman), are to be carried out by a Competent Operator.

- Lock and tag out equipment
- Record equipment data
- Check all mounting bolts and clamps are secure and tight
- Check vessel support frame and wheels for soundness
- Visual inspection of pump for any damage
- Check exhaust box for cleanliness (if fitted)
- Check condition of seals
- Check 2 way ball valve for leakage
- Make sure all timers are operational
- Check operation of Pressure Relief Valve
- Check in-line gauge filter
- Inspect condition of airlines and fittings
- Check operation of swing check valve (if fitted)
- Check condition of venturi nozzle
- Test the operation of the SV440-CVCD pump prior to returning to service
- Make note on the field report of any findings that may require additional work

PUMP MAINTENANCE CHECKLIST

DESCRIPTION	COMMENT	MAINTENANCE FREQUENCY			
		DAILY	WEEKLY	MONTHLY	ANNUALLY
Pump use and timing	Check operation of pump prior to use.	X			
Overall visual inspection	Complete overall visual inspection to be sure all equipment is operating and safety systems are in place.	X			
Check ball valve seals	Assure that all seals are in good condition and not worn, split or damaged.		X		
Check exhaust box	Check exhaust box for foreign material and clean as necessary.		X		
Check airlines and fittings	Inspect airlines for any deterioration, check fittings for cracks and leaking.		X		
Check bolts	Check and secure all clamps and bolts.		X		
Check in-line gauze filter	Check in-line filter for cleanliness and obstructions. Clean as necessary.		X		
Check venturi nozzle and PRV	Check the condition of the venturi nozzle. Check operation of the PRV.			X	
Pressure Vessel Inspection	Inspect the vessel for wear, cracks and/or damage.				X
Full Service and PRV	Conduct a full service on the pump and replace the PRV.				X

10. SPARE PARTS

ITEM NO.	PART NO.	DESCRIPTION	MATERIAL	PAINT THICKNESS
1	SV440-1	Crash Frame Assembly	Mild Steel	80µm
2	SV440-2	Panels for Crash Frame	Mild Steel	80µm
3	SV440-1-1	Exhaust Box	Mild Steel	80µm
4	SV200-1	200Ltr Vessel	Stainless Steel	80µm
5	SV440-11	4" suction Manifold	Mild Steel	80µm
6	SV440-12	4" Discharge Manifold	Mild Steel	80µm
7	SV440-9	4" Suct/Disc Manifold RBV	Mild Steel	80µm
17	SV440-15-2-1	380CFM Diffuser Stem T/C	1045 Steel	80µm
18	SV440-15-1	380CFM Venturi Housing	Mild Steel	80µm
19	SV440-15-2	380 CFM Diffuser	1045 Steel	80µm
20	SV900-6	380CFM Venturi Nozzle	Brass	N/A
21	SV440-5	4" Actuator Bkt & RBV Arms	Mild Steel	80µm
22	SV440-4	4" Ball Valve	Stainless Steel	N/A
23	SV440-3	4" Rotary Actuator	Aluminum Alloy	N/A
25	SV200-22	1 1/2" Diffuser Ball Valve	Stainless Steel	N/A
26	SV20-39	2" Rotary Actuator	Aluminum Alloy	N/A
27	SV20-38	2" Ball Valve	Stainless Steel	N/A
28	SV150-8	Air Manifold Tank	Mild Steel	80µm
30	SV906-5	2" Ball Valve (Lockable)	Stainless Steel	N/A
31	SV940	1/2" PRV	Brass	N/A
49	SV440-10	4" T/Clover to 4" BSP	1045 Steel	80µm
72	SV999	Decal Plate	Mild Steel	80µm

ORIGINAL DRAWING REFERENCE: Copyright Information Disclosed in this document is Confidential and shall not be reproduced, copied or distributed without express permission.	DO NOT SCALE DRAWING SCALE: 1:20 SHEET 1 OF 7	REMOVE AND BREAK SHARP EDGES SHEET SIZE A3 VERSION REVISION
TITLE Continuous Vacuum Pump 560CFM		
DATE: 10/25/2023 8:53:44 AM NAME: Deb Berts APPROVED:		DWG NO. SV440-CVCD-560

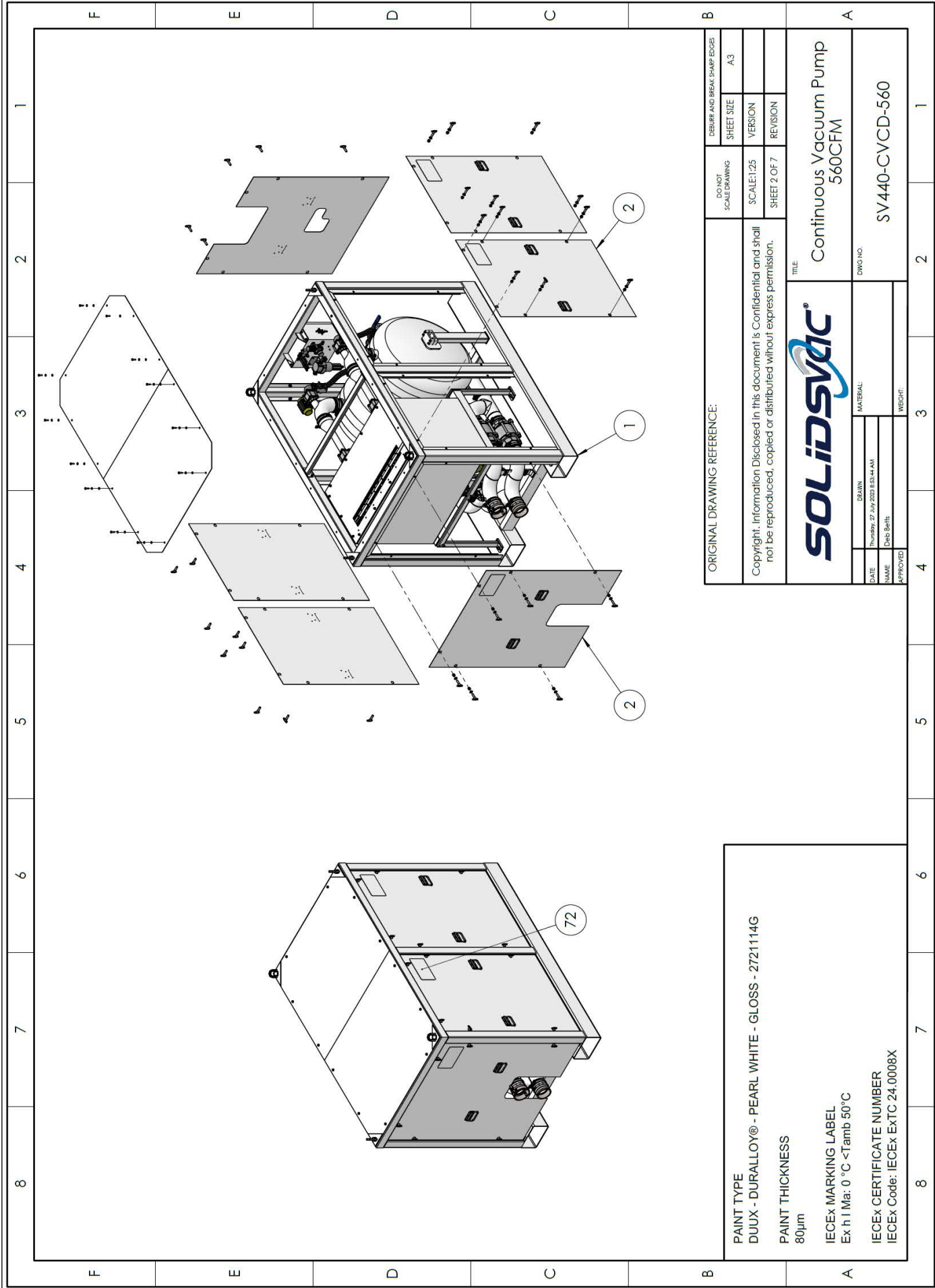

ORIGINAL DRAWING REFERENCE:		DO NOT SCALE DRAWING	DEBUR AND BREAK SHARP EDGES
Copyright. Information Disclosed in this document is Confidential and shall not be reproduced, copied or distributed without express permission.		SCALE: 1:25 SHEET 2 OF 7	SHEET SIZE A3
		VERSION	REVISION
Continuous Vacuum Pump 560CFM		TITLE	
DATE Thursday, 27 July 2023 13:44 AM	DRAWN	DWG. NO.	
NAME Deb Bells	MATERIAL	SV440-CVCD-560	
APPROVED	WEIGHT		

PAINT TYPE DUUX - DURALLOY® - PEARL WHITE - GLOSS - 2721114G
PAINT THICKNESS 80µm
IECEX MARKING LABEL Ex h I Ma: 0 °C <Tamb 50°C
IECEX CERTIFICATE NUMBER IECEX Code: IECEX ExTC 24.0008X

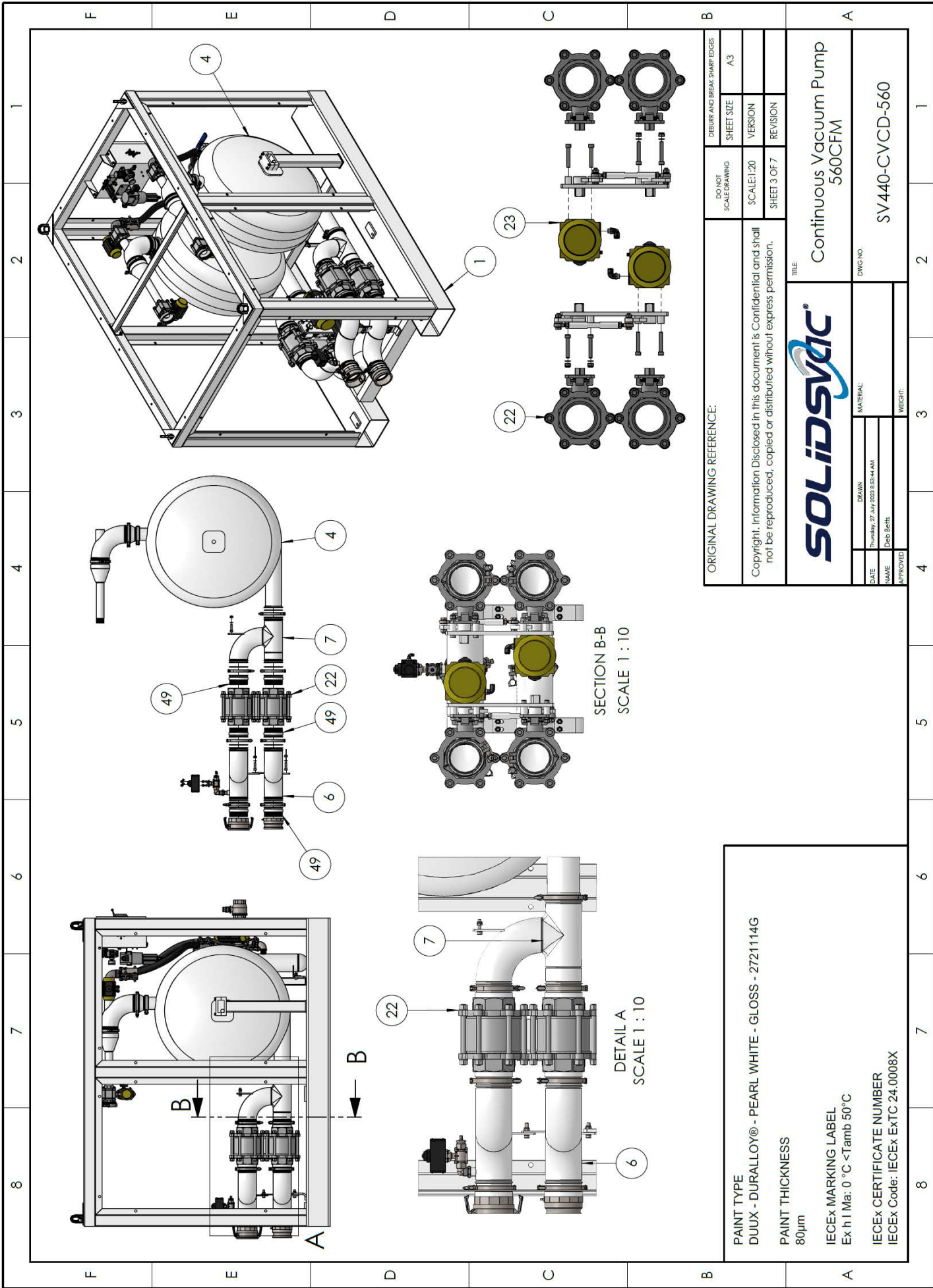

DO NOT SCALE DRAWING		DESIRE AND BREAK SHARP EDGES	
SCALE: 1:20		SHEET SIZE: A3	
SHEET 3 OF 7		VERSION	
		REVISION	

ORIGINAL DRAWING REFERENCE:			
Copyright. Information Disclosed in this document is Confidential and shall not be reproduced, copied or distributed without express permission.			
		TITLE: Continuous Vacuum Pump 560CFM	
		DWG NO: SV440-CVCD-560	
DATE	DRAWN	MATERIAL	
NAME	Thursday 27 July 2023 08:44 AM		
APPROVED	Deb Behl	WEIGHT	

PAINT TYPE DUUX - DURALLOY® - PEARL WHITE - GLOSS - 2721114G PAINT THICKNESS 80µm IECEX MARKING LABEL Ex h I Ma: 0 °C <Tamb 50°C IECEX CERTIFICATE NUMBER IECEX Code: IECEX EXTC 24-0008X
--

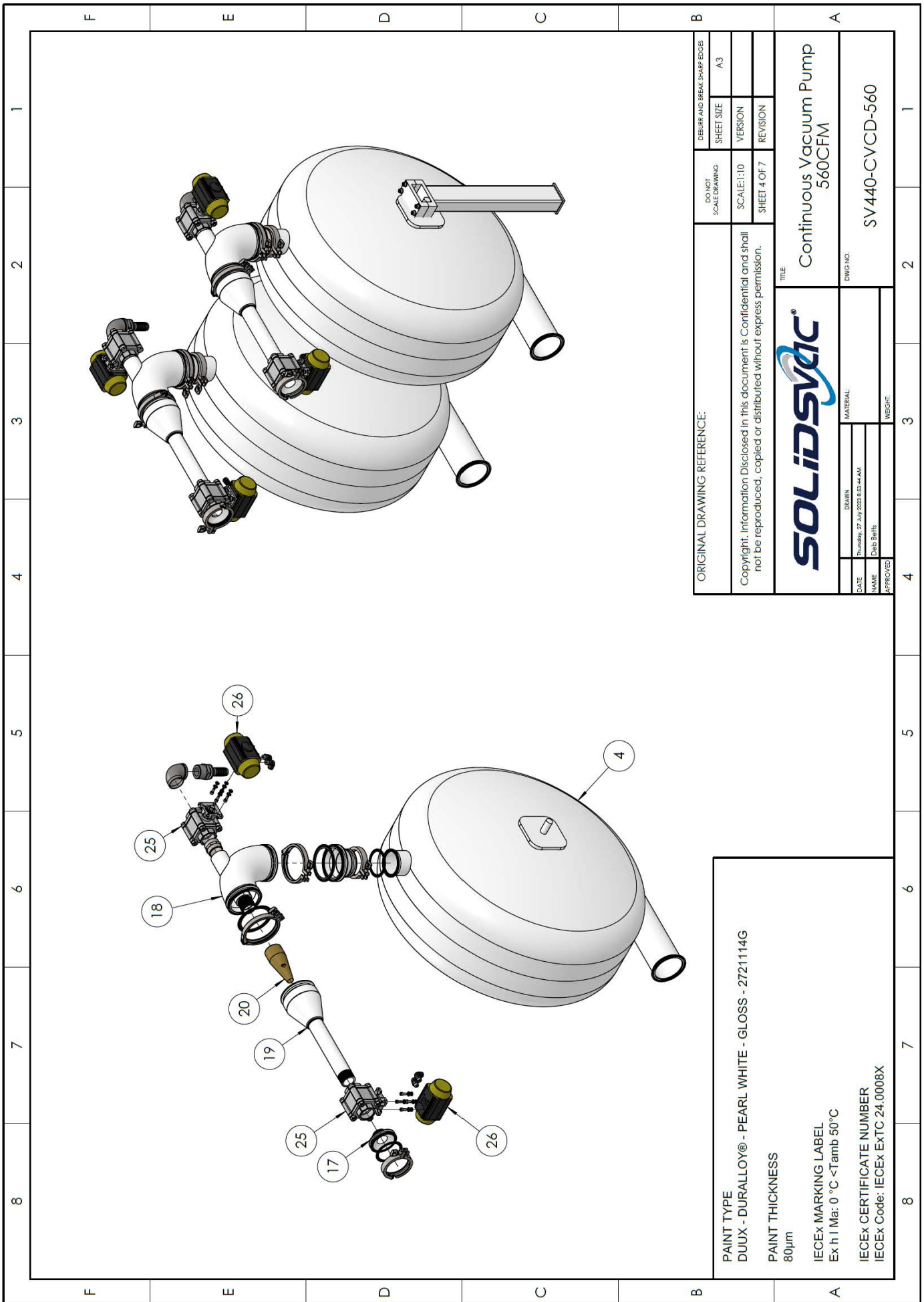

ORIGINAL DRAWING REFERENCE:	DO NOT SCALE DRAWING	ESURE AND BREAK SHARP EDGES
	SCALE: 1:10	SHEET SIZE A3
	SHEET 4 OF 7	VERSION
		REVISION

Copyright: Information Disclosed in this document is Confidential and shall not be reproduced, copied or distributed without express permission.

		TITLE:	
		Continuous Vacuum Pump 560CFM	
DATE	DRAWN	DWG. NO.	
Thursday 27 Jul 2023 8:59:44 AM		SV 440-CVCD-560	
NAME	MATERIAL:		
Deb Bells			
APPROVED:	WEIGHT:		

PAINT TYPE DUUX - DURALLOY® - PEARL WHITE - GLOSS - 272114G PAINT THICKNESS 80µm IECEX MARKING LABEL Ex h I Ma: 0 °C < Tamb 50°C IECEX CERTIFICATE NUMBER IECEX Code: IECEX EXTC 24.0008X
--

F	E	D	C	B	A
1	2	3	4	5	6
1	2	3	4	5	6
1	2	3	4	5	6
1	2	3	4	5	6
1	2	3	4	5	6
1	2	3	4	5	6
1	2	3	4	5	6
1	2	3	4	5	6
1	2	3	4	5	6
1	2	3	4	5	6
1	2	3	4	5	6
1	2	3	4	5	6
1	2	3	4	5	6
1	2	3	4	5	6
1	2	3	4	5	6
1	2	3	4	5	6
1	2	3	4	5	6
1	2	3	4	5	6
1	2	3	4	5	6
1	2	3	4	5	6
1	2	3	4	5	6
1	2	3	4	5	6
1	2	3	4	5	6
1	2	3	4	5	6
1	2	3	4	5	6
1	2	3	4	5	6
1	2	3	4	5	6
1	2	3	4	5	6
1	2	3	4	5	6
1	2	3	4	5	6
1	2	3	4	5	6
1	2	3	4	5	6
1	2	3	4	5	6
1	2	3	4	5	6
1	2	3	4	5	6
1	2	3	4	5	6
1	2	3	4	5	6
1	2	3	4	5	6
1	2	3	4	5	6
1	2	3	4	5	6
1	2	3	4	5	6
1	2	3	4	5	6
1	2	3	4	5	6
1	2	3	4	5	6
1	2	3	4	5	6
1	2	3	4	5	6
1	2	3	4	5	6
1	2	3	4	5	6
1	2	3	4	5	6
1	2	3	4	5	6
1	2	3	4	5	6
1	2	3	4	5	6
1	2	3	4	5	6
1	2	3	4	5	6
1	2	3	4	5	6
1	2	3	4	5	6
1	2	3	4	5	6
1	2	3	4	5	6
1	2	3	4	5	6
1	2	3	4	5	6
1	2	3	4	5	6
1	2	3	4	5	6
1	2	3	4	5	6
1	2	3	4	5	6
1	2	3	4	5	6
1	2	3	4	5	6
1	2	3	4	5	6
1	2	3	4	5	6
1	2	3	4	5	6
1	2	3	4	5	6
1	2	3	4	5	6

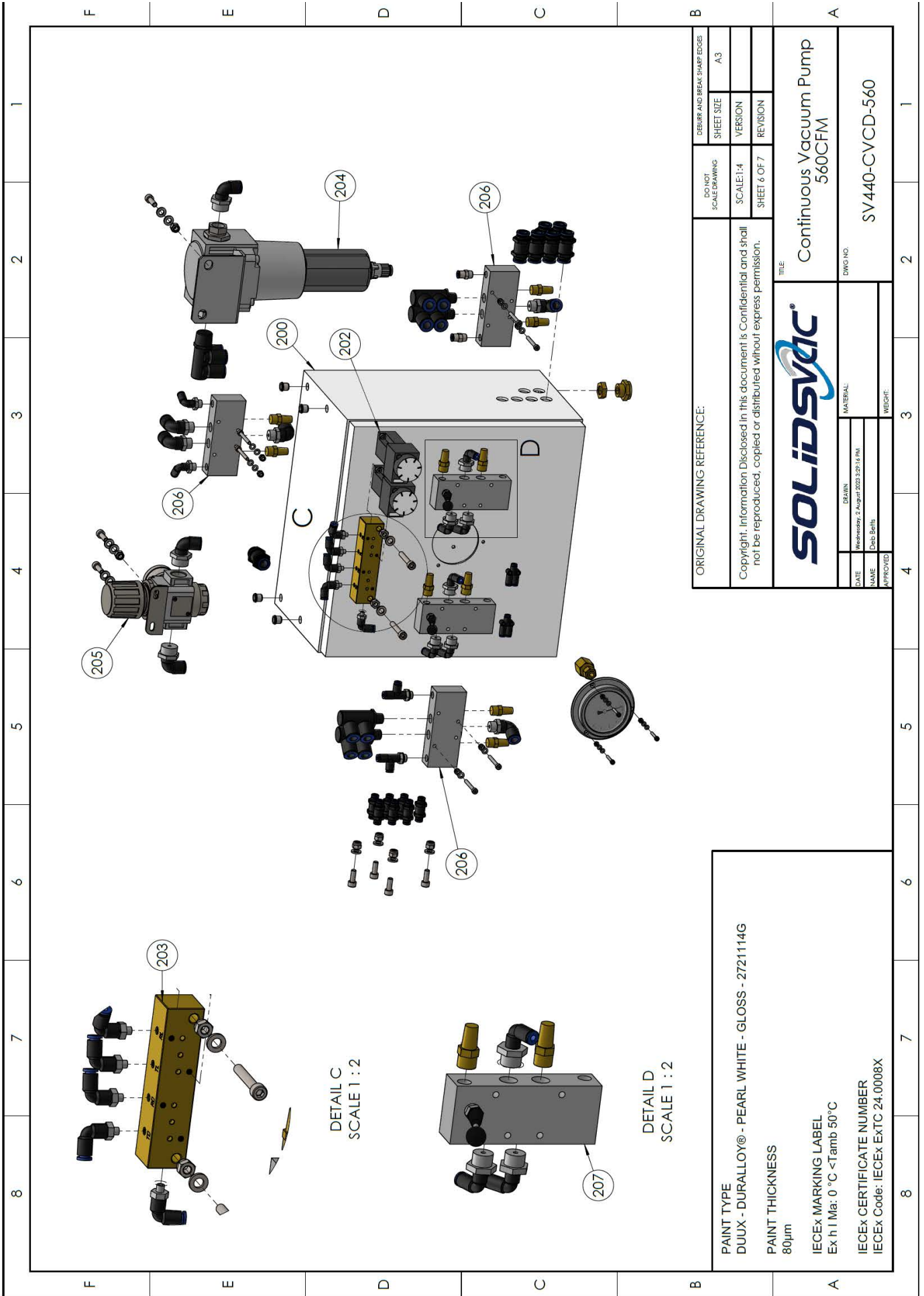

ORIGINAL DRAWING REFERENCE:		DO NOT SCALE DRAWING	DEBURR AND BREAK SHARP EDGES
Copyright, Information Disclosed in this document is Confidential and shall not be reproduced, copied or distributed without express permission.		SHEET SIZE: A3	SHEET SIZE: A3
SOLIDSVAC®		SCALE: 1:4	VERSION
TITLE: Continuous Vacuum Pump 560CFM		SHEET 6 OF 7	REVISION
DATE: Wednesday, 2 August 2023 3:29:14 PM		DWG NO: SV440-CVCD-560	
DRAWN: Deb-Berth		MATERIAL:	
DATE: Wednesday, 2 August 2023 3:29:14 PM		MATERIAL:	
NAME: Deb-Berth		MATERIAL:	
APPROVED:		WEIGHT:	

PAINT TYPE	
DUUX - DURALLOY® - PEARL WHITE - GLOSS - 272114G	
PAINT THICKNESS	
80µm	
IECEX MARKING LABEL	
Ex h I Ma: 0 °C < Tamb 50°C	
IECEX CERTIFICATE NUMBER	
IECEX Code: IECEX ExTC 24.0008X	

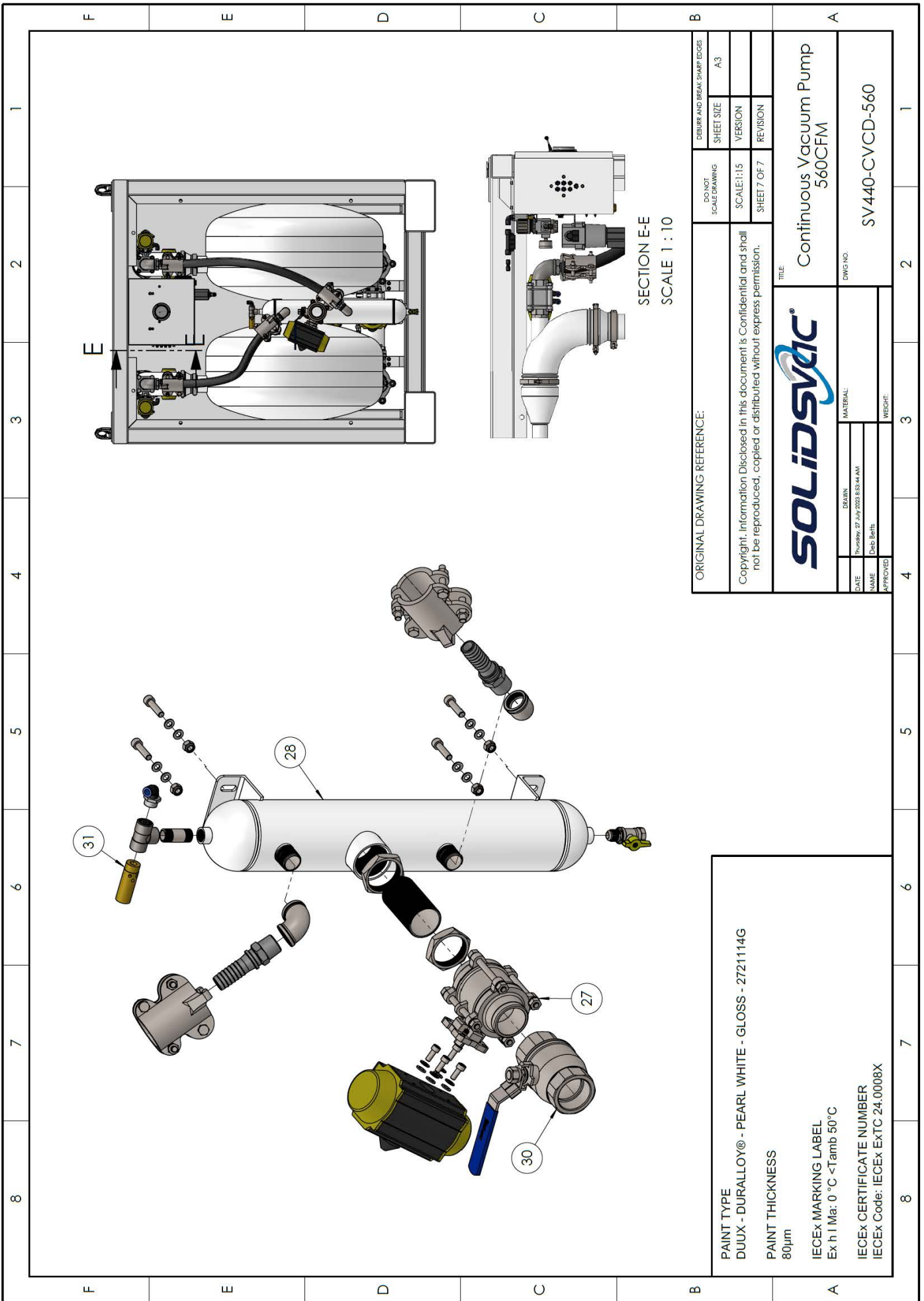

ORIGINAL DRAWING REFERENCE:	ISO NOT SCALE DRAWING	DEBUR AND BREAK SHARP EDGES
		SHEET SIZE A3
Copyright: Information Disclosed in this document is Confidential and shall not be reproduced, copied or distributed without express permission.	SCALE: 1:15	VERSION
	SHEET 7 OF 7	REVISION

		TITLE	Continuous Vacuum Pump 560CFM
		DWG. NO.	SV440-CVCD-560
DATE	THURSDAY, 27 JULY 2023 8:53:44 AM	MATERIAL	
NAME	Diego Salas	APPROVED	
WEIGHT			

PAINT TYPE
 DUUX - DURALLOY® - PEARL WHITE - GLOSS - 272114G
 PAINT THICKNESS
 80µm
 IECEX MARKING LABEL
 Ex h I Ma: 0 °C < Tamb 50°C
 IECEX CERTIFICATE NUMBER
 IECEX Code: IECEX ExTC 24.0008X



JOB SAFETY ANALYSIS

Note: It is recommended that a site-specific JSA is conducted prior to operation of the unit.

JOB SAFETY ANALYSIS

SOLIDSVAC SV440-CVCD SLURRY PUMP

Date Of Audit – June 2020.

Equipment/Task: Set-up and operate Solidsvac Solids/Slurry Pump.

Note: Site Safety requirements MUST be adhered to at all times. Personal Protective Equipment including approved safety eyewear and hearing protection are to be worn at all times whilst operating this equipment.

STEP #	JOB STEPS	HAZARDS/WHAT CAN GO WRONG	CONTROLS & RISK REDUCTION
1	Selecting the right pump.	Selecting the incorrect pump/equipment to transfer media that is either hazardous in itself or becomes hazardous when transferring can result in delay of operating and injury.	Site-specific JSA MUST be conducted prior to operation to identify site-specific media risks & hazards.
2	Siting the pump.	The pump may be unstable.	Site the pump on a reasonably flat, level & stable surface, or on a suitable straddle frame.
3	Connecting discharge hose range to pump.	(a) Use of inappropriate non pressure rated discharge hose, hose or couplers may cause discharge hose range failure.	Ensure minimum 2" discharge range is used rated to 10Bar. Hose may be rubber or poly. The pump utilises the camlock coupling system. Use Solidsvac supplied FRAS rubber Stainless Steel camlock ended pressure rated hose ass'y to enable safe connection.
		(b) Sharp bends, tee pieces and valves in a discharge line can cause blockages.	Ensure discharge hose range has no sharp bends or tee pieces and is free of restrictions such as reductions in hose diameter or gate valves etc.
		(c) Discharge hose range may move particularly at discharge exit point.	Ensure discharge hose range is secured at appropriate points along its length and particularly at discharge exit point.
4	Connecting the suction hose to the pump.	Sharp bends, tee pieces and valves in a suction hose can cause blockages.	Wear eye and hearing protection. Hold hose firmly. Ensure suction hose range has no sharp bends or tee pieces and is free of restrictions. Ensure suction hose couplings are correctly engaged and have safety clips fitted.

JOB SAFETY ANALYSIS

SOLIDSVAC SV440–CVCD SLURRY PUMP

Date Of Audit – June 2020.

Equipment/Task: Set-up and operate Solidsvac Solids/Slurry Pump.

Note: Site Safety requirements MUST be adhered to at all times. Personal Protective Equipment including approved safety eyewear and hearing protection are to be worn at all times whilst operating this equipment.

STEP #	JOB STEPS	HAZARDS/WHAT CAN GO WRONG	CONTROLS & RISK REDUCTION
5	Connecting the air supply hose to the pump. Air hose should be blown clean before connection.	(a) Compressed air can be dangerous and may cause injury. Blowing air supply hose clean can cause eye, hearing or physical injury if not carried out in a controlled manner.	Ensure air hose is turned off completely and that the pump air inlet ball valve is closed before connection.
		(b) Air supply hose can 'fly off' if not properly connected.	Ensure air line couplings are correctly engaged and have safety clips fitted.
6	Pump Operation – Unblocking Suction Hose or Suction Wand.	Reverse flushing of suction hose or suction wand nozzle with high pressure water hose can result in eye injury.	If disconnecting suction hose or suction wand – stop the pump. Wear approved eye protection.
7	Pump Operation – Unblocking Discharge Hose Range Blockages.	Pressure in discharge range has potential to cause eye and physical injury.	STOP THE PUMP. DO NOT DISCONNECT ANY DISCHARGE HOSE RANGE COMPONENT WHILST PUMP IS OPERATING. Depressurise the discharge hose range by operating a manual pressure relief valve on the pump or within the hose range (if fitted) OR, using EXTREME CAUTION, loosen hose couplings upstream of the estimated blockage point (i.e. between pump and blockage) to safely vent residual pressure before attempting to fully open hose joints to clear the blockage.
8	Pump Operation – Discharge Hose Range Exit Point.	Injury can be caused by high velocity material ejected from discharge point.	Do not stand in front of the discharge hose range exit point. Minimise risk by directing this point away from traffic zones. Use Solidsvac supplied Dead Head/Drop Box to reduce velocity & control material at discharge point.
9	Disconnecting Pump from Air Supply.	Injury may result from uncontrolled whipping of pressurised air hose.	Before disconnecting air hose isolate it upstream & open the Pump Air Supply Ball Valve to release residual pressure from the air line.

Model Number

Serial Number

Date of Manufacture

Inspected by



U1/ 5-7 Boeing Place - Caboolture - QLD 4510 - Australia

+61 456 000 665 / info@solidsvac.com

www.solidsvac.com