

# SOLIDSVAC<sup>®</sup>

**SOLIDS PUMPING SYSTEMS**

## SV-VP Vac-Pack

The Vac-Pack is a 100% compressed air powered mobile unit designed to deliver a continuous 25" Hg of vacuum with high in-line airflows. When combined with vacuum rated skips or tanks, the Vac-Pack can provide operators an economical alternative to using vac-trucks in certain applications.

- Delivers Continuous High Vacuum
- Exceptionally Low Maintenance
- Compact and Highly Mobile
- Available in 230/380/600/900/1200 CFM
- Intrinsically safe



U1/ 5-7 Boeing Place - Caboolture - QLD 4510 - Australia

+61 456 000 665 / [info@solidsvac.com](mailto:info@solidsvac.com) / [www.solidsvac.com](http://www.solidsvac.com)

# SV-VP Vac-Pack

## Vac-Pack Applications

When combined with Solidsvac performance enhancing accessories, the Vac-Pack is fully capable of generating vertical lifts in excess of 40 metres. A low cost, highly productive Vac-Pack is a must for those involved in FPSO and storage tank cleaning, high volume or restricted access desludging operations.

### Vac-Pack High Lift Application

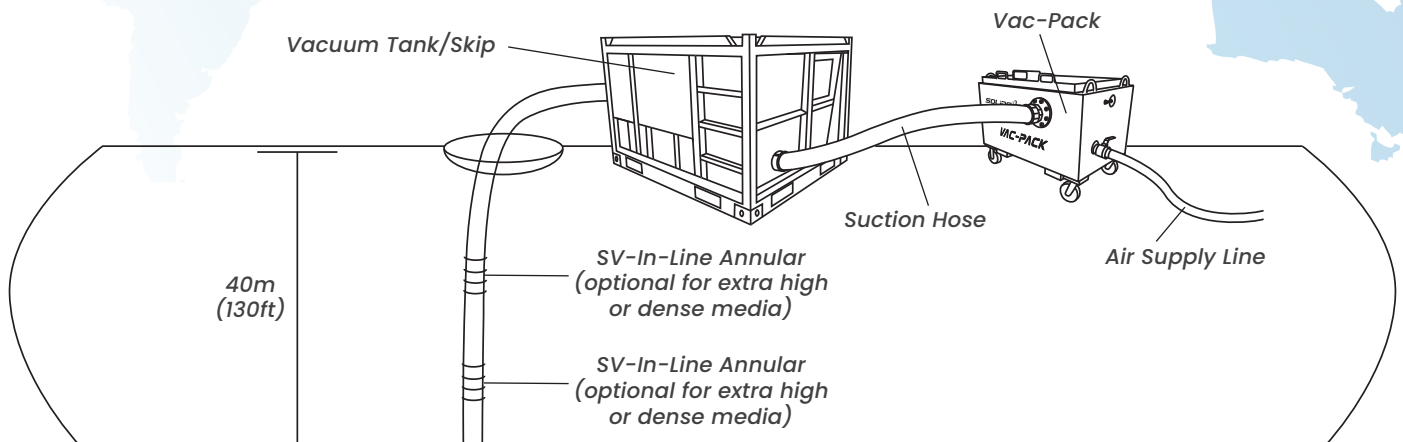

### Vac-Pack Robotic Crawler Application

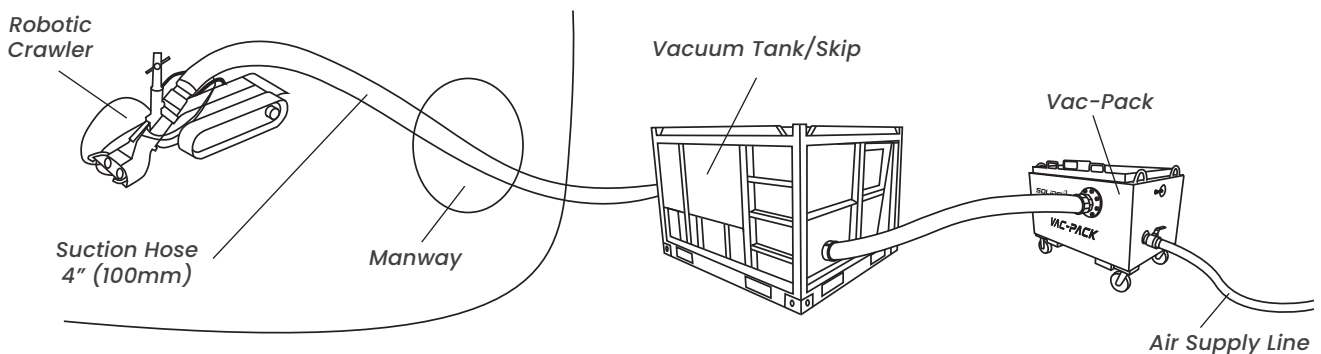

#### TECHNICAL INFORMATION

	METRIC	US IMPERIAL
Length	1350 mm	53"
Width	890 mm	35"
Height	960 mm	37.7"
Weight	280 kg	617 lb
CFM Options	230/380/600/900/1200 cfm	
Vacuum	25" Hg	
DBA	85 (1 metre @ 230 cfm)	
Air Connection	2" (50mm) BSP/NPT	
Suction Inlet	4" (100mm) Camlock	

**SOLIDSVAC** / SOLIDS PUMPING SYSTEMS

U1/ 5-7 Boeing Place - Caboolture - QLD 4510 - Australia

+61 456 000 665 / info@solidsvac.com / www.solidsvac.com