

SOLIDSVAC

SOLIDS PUMPING SYSTEMS



SV150-CVCD Operations Manual



201 First Avenue - Bribie Island - QLD 4507 - Australia

+61 456 000 665 / info@solidsvac.com / www.solidsvac.com

CONTENTS

Description	Page
Safety First	
1. Operation Overview	3
2. Design Registration	3
3. Technical Data	4
4. Schematic	5
5. Pump Set-Up	6
6. Operation, Timer Cycling & Adjustments	7
7. Maintenance	8
8. Accessories	13
9. Operation Risk Assessment	14
10. Job Safety Analysis	27



QR CODE

Scan the QR Code for an electronic version of this Operations Manual.

SAFETY FIRST

CAUTION & GENERAL SAFETY

This manual contains important information concerning the installation, operation and maintenance of the Solidsvac Pump, Model SV150-CVCD. To prevent injury to personnel or equipment damage, this manual MUST be read and understood by those responsible for the installation, operation and maintenance of the equipment.

THIS OPERATION MANUAL MUST BE USED IN CONJUNCTION WITH BOTH SITE SPECIFIC RA AND JSA'S.

- Isolate, tag out and disconnect the air supply to the unit prior to working on any part of the system
- Lift the equipment only at the lifting points provided
- The pump should be installed in a safe level area, which provides adequate access for operating the equipment
- Ensure all hoses are in good condition, correctly rated and certified for the service in which they are to be used
- Inspect the unit regularly for damaged or worn components
- All covers must be fitted prior and during operation
- Air pressure should NEVER exceed rated pressure
- Tie down points (if fitted) must NOT be used as lifting point

CAUTION: BE AWARE OF RETAINED MATERIAL IN THE TANK INCREASING WEIGHT

SOLIDSVAC PUMPS EACH HAVE SPECIFIC COMPRESSED AIR REQUIREMENTS DEPENDING ON THE JET PACK FITTED.

The operator must ensure that an appropriate and adequate air supply is available depending on the model and Jet Pack in use.

All Solidsvac Pumps require a minimum operating pressure of 500kpa and have a maximum operating pressure of 720kpa (105psi).

It is recommended that a 40mm (1 1/2") i.d. air hose is used for compressed air supply to the pump.

The Discharge hose MUST be no smaller in diameter than the pumps outlet 75mm (3") preferably a self-supporting type and secured at regular intervals.

WARNING: THE PUMP-OUT LINE MUST BE SECURED AT THE EXIT POINT

1. OPERATIONAL OVERVIEW

The Solidsvac SV150-CVCD operates a simultaneous process of vacuum loading together with a pressure discharge and can recover and continuously transfer a wide range of flowable and semi-flowable materials.

Operation is fully automatic and the Solidsvac SV150-CVCD features no internal workings. The 100% air operated Solidsvac produces high vacuum and discharge airflows whereby horizontal suction runs in excess of 50 metres, and discharges in excess of 500 metres are readily achievable.

WARNING

Correctly rated hoses and/or piping MUST be used in conjunction with the appropriate fittings and safety devices on all connections.

telephone +61 456 000 665

email info@solidsvac.com

2. DESIGN REGISTRATION

The Solidsvac SV150-CVCD has a Certificate of Plant Design Registration from Workcover NSW, Australia. A copy of which may be obtained by contacting **Solidsvac Pumps**.

DESIGN REGISTRATION # PV-6-198163/16

Technical Standards

- AS2971-2007 Serially Produced Pressure Vessels
- AS4343-2005 Pressure Equipment – Hazard Levels
- AS1210-1210 Pressure Vessels

3. TECHNICAL DATA

TECHNICAL DATA	METRIC	US IMPERICAL
Height	1260 mm	47"
Width	980 mm	38.5"
Length	1500 mm	60"
Weight	390 kg	848 lb
Air Inlet	40 mm	1-1/2" BSP
Suction Inlet	75 mm	3"
Discharge Outlet	75 mm	3"
Suction Lift	7.9m @ 100cfm	26' 2" @ 100cfm
	9.2m @ 180cfm	30' @ 100cfm
	11.5m @ 100cfm	37' 7" @ 100cfm
Air Consumption Options	2.8 m3/Min Jetpack & 2.8 m3/Min Discharge	100 cfm Jetpack & 100 cfm Discharge
	5.0 m3/Min Jetpack & 2.8 m3/Min Discharge	180 cfm Jetpack & 100 cfm Discharge
	6.5 m3/Min Jetpack & 2.8 m3/Min Discharge	230 cfm Jetpack & 100 cfm Discharge
Delivery	500+ m	1640+ ft
Displacement Cycle	130 ltr	34 gal
Operating Pressure	7 bar (Required) @ 690 kPa	100 psi (Required)
Vacuum Options	73 to 86,5 kPa	21,5" to 25,5" Hg
Maximum Solids	55 mm	2.5"
Water Throughput	800 lpm	211 gpm

5. PUMP SET-UP

Before commencing operation, Solidsvac strongly recommends each user reads and understands the Operation Manual supplied with each unit and available on line or via the QR code on each pump.

Note: No formal training is required to operate the SV150-CVCD however, it is essential for the safe operation of this equipment that the Operator has read and understands the SV150-CVCD Operation Manual.

Solidsvac also recommend that a site-specific Risk Assessment (RA) and Job Safety Analysis (JSA) be undertaken prior too the commencement of any works involving the Solidsvac.

Any recommendations arising from these should be considered additional to these:

- The unit and all hoses and fittings are in good working order and fit for purpose
- The source of compressed air is sufficient in both volume and pressure
- The correctly rated compressed air supply hose is used (40mm or 1&1/2"ID)
- All equipment covers are correctly fitted and properly secured
- The Discharge Hose is adequately secured to prevent "hose whip"
- The Discharge Area has both barriers and signage in place to protect personnel
- The discharge area has suitable warnings to protect personnel
- The correct PPE is available and worn by the operator
 - Eye Protection
 - Hearing Protection
 - Gloves
 - Safety Boots
- Set the Solidsvac pump in a safe level location as close to the material to be pumped as possible
- Attach both the Suction and discharge hoses along with any accessories in use and ensure all safety clips are in place

Note: If a flexible Discharge Hose is to be used, it MUST be secured at regular intervals to prevent "hose whip"

- Attach the compressed air supply line to the pump and fit the appropriate safety clips
- Ensuring the Main Air Supply Valve is in the "OFF" position, turn the compressed air supply valve on at the source.
- The pump is now ready for use

MATERIAL EXCLUDED FROM PUMPING

Solidsvac recommends that the any liquids that fall within the scope of the below class should not be pumped with any Solidsvac unit. Solidsvac also recommends that a site specific JSA should be conducted with reference to any other type of material being pumped.

- Class IIIA liquids with a flash point equal to or greater than 140 °F (60 °C), but less than 200 °F (93 °C) have a NFPA 704 flammability rating of 2
- Class IIIB liquids with a flash point equal to or greater than 200 °F (93 °C) have a NFPA 704 flammability rating of 1

OPERATING ENVIRONMENT PARAMETERS

The Solidsvac SV150-CVCD can operate within environments ranging from -20°C to +60°C and all humidity.

6. OPERATION

With the Suction hose out of the material to be conveyed, turn the pumps Main Air Supply Valve "ON".

The pump will commence operation.

NOTE: DRY OPERATION WILL NOT DAMAGE THE PUMP

With the system energized and the unit cycling, check both pneumatic gauges and ensure the correct pressure is available to commence operations. The Primary Gauge indicates the working pressure and should indicate approximately 7 Bar, or 100 Psi is available. The smaller Secondary Gauge indicates control system pressure and MUST always remain above 5.8 Bar or 85 Psi, when operating.

LOAD & DISCHARGE TIMERS

The Load and Discharge cycles are controlled by adjustable 0-30 Sec pneumatic timers located within the control box.

Due to the continuous system of the SV150-CVCD the pneumatic timers MUST be set at an equal setting (i.e., 5/5 or 10/10 etc). The load cycle will determine the overall setting for the timers, therefore if optimal load time is 5 seconds, then discharge MUST be set to 5 seconds.

Solidsvac recommend that the operator allows the pump to cycle twice prior to transferring material to ensure all aspects of the pump set up are functioning correctly and safely. It is advisable to introduce the Suction Wand (If fitted) or Suction Hose to the material to be conveyed for an initial single cycle and observe that all aspects of the pump set-up are functioning correctly and safely. If no adjustments are required, commence continuous pumping operations.

IMPORTANT: TIMERS ARE REQUIRED TO BE ADJUSTED TOGETHER EQUALLY

PNEUMATIC GAUGE CONTROLS

The SV150-CVCD is fitted with 2 pneumatic pressure gauges to ensure the operator has a correct reading of control and operational air pressure. A small, mounted gauge inside the control box will displayed the regulated air for all controls running at 586kpa (85psi).

The second pressure gauge is mounted on the exterior of the control box and displays the working pressure of the pump. This gauge will only show the operational air pressure at the pump, this is not to be assumed as the pressure output of the compressor. Solidsvac recommend checking the compress's gauge to obtain a reading.



Pneumatic controls
pressure gauge with regulator



Operational
pressure gauge

7. MAINTANENCE

The Solidsvac SV150-CVCD generally require a minimum of maintenance although Solidsvac recommend the following be adhered to as a minimum:

DAILY

- Check that all fittings and connection are serviceable

WEEKLY

- The unit's auto drain filter be inspected and cleaned as required
- The exhaust box be inspected and cleared of any carry over material

MONTHLY

- Carry out both the daily and weekly maintenance requirements
- Using "service air only", and with NO HANDS WITHIN THE UNITS VALVE ARRANGEMENT cycle the unit and carry out a visual inspection of the valve linkages.
- In very harsh environments, a spray of CRC penetrant or similar is recommended

SERVICE AIR

It is recommended that only service air is used when performing maintenance on the pump. That is air plugged in to the pneumatics not through the air manifold or venturi. A service air connector can be provided with any unit upon request.

MAIN AIR FILTER

The main air filter is located against the exhaust box and is self-draining, however it should be inspected weekly.

EXHAUST BOX

All SV150-CVCD variants are fitted with an exhaust box located in the front of the unit. The exhaust box can be accessed for cleaning by removing the top lid.

Hosing the exhaust box will ensure debris is free from blocking exit vent. Blocking of the exit vent and exhaust box in general will reduce vacuum performance.



SAFETY FIRST

THE SV150-CVCD MUST BE ISOLATED FROM ITS AIR SUPPLY AND TESTED DEAD PRIOR TO ANY MAINTENANCE WORK BEING UNDERTAKEN.

FAILURE TO DO SO COULD RESULT IN SERIOUS INJURY OR DEATH.

7. MAINTENANCE

In use, the Solidsvac SV150-CVCD requires little to no maintenance, however Solidsvac recommends that the following strict measures are taken to ensure pump remains in good working order.

Maintenance, repairs, and the disassembling of the unit be carried out by any can be carried out by any qualified Fitter with a basic knowledge of pneumatics.

SERVICE TIPS

- Set up a maintenance schedule and follow it diligently.
- Clean the machine areas before removing pneumatic components.
Note: When steam cleaning or using water to clean a machine, be sure that filler openings, breather caps etc are protected from possible entry of water into the system.
- Use clean plastic plugs to cover the ends of disconnected lines or to plug openings when working on a pneumatic system.
- A clean workbench is an absolute 'must' when servicing components. An industrial - type vacuum cleaner is a valuable aid in removing dust, dirt and tiny metal particles from the work area.
- Check the condition of your tools – they should be clean. Always use hammers made of plastic or leather, so there is no danger of metal chips getting into components.
- When removing parts for service, clean them and then store them in plastic bags or other clean containers until they are install again .
- When cleaning pneumatic parts, use extreme care to ensure that the cleaning fluid is non - flammable and compatible with the system
- Use common-sense precautions to prevent dirt entering components that have been temporarily removed from the circuit.

SYSTEM PERFORMANCE

Pneumatic problems that affect system flow and pressure are not always easy to locate. The system testing procedure described later in this section is based on a useful step by step approach to troubleshooting. Troubleshooting charts make the fault finding process easier and faster.

EFFECTS OF A DROP IN SYSTEM FLOW RATE

- A pressure drop will affect the speed and cycle times of a pneumatic machine; actuators will not extend, retract, or rotate at the required speed. Actuator control will become jerky with inconsistencies in flow as cylinders and motors are supplied at different rates. In many complex pneumatic systems, the sequencing and positioning of component operations will be affected as cycle times become thrown out of programmed control.
- The compressor's discharge flow rate should be checked first to ensure that the drop in flow is not a problem of internal leakage or incorrect setting of compressor controls

EFFECTS OF DROPS IN PRESSURE

The major causes of pressure drop include :

- pipework restrictions (for example, incorrect sizing) fitting restrictions and sharp corners
- incorrect pressure settings
- sudden enlargement in fluid conductors
- long lengths of fluid conductors
- component leakage (internal and external)
- broken valve springs
- blocked or crimped air lines
- loose fittings
- valves not sealing correctly because of contaminants some combination of the above causes.

SYSTEM TESTING PROCEDURES

Pneumatic systems, like all machines, require routine maintenance to ensure reliability. However, there are still times when problems occur and must be located quickly and efficiently, especially in production applications. A step - by - step method has been devised as a way of finding and solving pneumatic problems quickly.

These steps are as follows:

STEP 1: KNOW THE SYSTEM -

Study the machine's technical specifications to obtain an understanding of how the system operates and the function of the machine's components. Obtain a circuit drawing and check the system through. Check the machine's maintenance records and commissioning test results if they are available.

STEP 2: ASK THE OPERATOR -

Determine the symptoms of the problem by asking the operator for a detailed description of the machine's normal operating performance.

STEP 3: INSPECT THE MACHINE -

Use your senses (touch, smell, sight, and hearing) to locate problems or damage such as noisy components, air leaks, malfunctioning components, and damaged air lines.

STEP 4: OPERATE THE MACHINE -

Operate the machine and check that the machine's gauges are reading 'normal' and that there are no unusual noises. The operation of the machine's controls should not be 'sticky' or 'spongy'. The machine's performance should not be slow, erratic –or non - existent.

STEP 5: LIST THE POSSIBLE CAUSES -

Once the fault has been located and recognised, list the possible causes – starting with the simplest.

STEP 6: REACH A CONCLUSION -

Use a troubleshooting chart to check the list of possible causes; then decide which is the most likely.

NB: 99% OF ALL ISSUES ARE AIR SUPPLY RELATED

SYSTEM MAINTENANCE

A pneumatic system is easy to maintain. However, like any other mechanism, it must be operated and maintained correctly.

Pneumatic systems can be damaged by excessive pressures, fluid contamination and by high operating temperatures.

Regular maintenance will reduce your pneumatic troubles. By using a regular maintenance programme (preventative maintenance) to care for a system, you can eliminate common problems and anticipate special ones. Problems can be corrected or averted before a breakdown occurs.

The following are the key problems that commonly need to be addressed in pneumatic maintenance:

- water - contaminated air
- poor air filtration
- incorrect pressure settings
- incorrect lubricator settings, resulting in sticking valves
- high air temperature
- loose supply lines
- faulty seals

IMPORTANCE OF CLEANLINESS

Cleanliness is of supreme importance when it comes to servicing pneumatic systems. Keep dirt and other contaminants out of the system. Small particles can score valve, cause seizing of components and clog orifices, resulting in expensive repair jobs.

When servicing a pneumatic system, always do the following to ensure cleanliness:

- Keep the compressor and machine's lubricating oil
- Keep the system clean
- Keep your work area clean
- Be careful when you change seal or components (take photos).
- Use caution with compressed air.
- Ensure all pneumatic components supply lines are secure

9. ACCESSORIES

Suction Wand – Attaches to the suction hose allowing the operator to stand upright and ambient air to be introduced at the material inlet

Strainer – available in wide range of sizes and attaches to the suction hose to prevent the ingestion of oversize particles

VacHead – An industrial vacuum head with squeegee brush allows the operator to stand upright, recovering material from hard surfaces i.e., an oil spill from a road surface.

NB: It is recommended that the suction timing cycle is set long when using this accessory.

Delivery Carousel – Controlled discharge to either a conveyor or multiple points/skips etc.

Hoses – A complete range of high-quality suction and discharge hoses are available

Hoover Head – Helps focus the vacuum and is ideal for recovering heavier material such as barite, oil sludge, mud or similar from tank bottoms and various hard surfaces.

Dropbox – Delivery of material to a skip, conveyor, or specific point

Service Kit – Contains all you need for basic maintenance on your pump



telephone +61 456 000 665

email info@solidsvac.com



OPERATIONAL RISK ASSESSMENT

telephone +61 456 000 665

email info@solidsvac.com

page 14

SOLIDSVAC / **SOLIDS PUMPING
SYSTEMS**

Objective:

The objective of the hazard identification and risk review process is to ensure all hazards are identified and accurately assessed for risk. Suitable and effective controls must be nominated and implemented to keep workplace

Context:

The Solidsvac SV150 Solids Pump is designed to be used in a coal mine for the purposes of pumping slurry / fluids. The Solidsvac SV150 Solids Pump will be in a stationary position on the floor.

Scope:

The Scope of the risk assessment as follows:-

- 1) Identify operational hazards associated with the use of the Solidsvac SV150 Mobile Solids Pump
- 2) Risk Assess each of the identified hazards
- 3) Implement controls to minimise any hazards to an acceptable level

Involved Persons / Stakeholders:

Risk Facilitator

Solidsvac Management / tradespeople

Assumption:

Supplier

Competent, comply with standards and drawings.

End User (Owner / hirer / User)

The end user has:

Competent (operators are trained, competent, authorised, etc.),

As per the instructions in the manual all personnel responsible for the installation, operation or maintenance of the equipment must read and understand the manual.

Procedures (change management, traffic rules, risk assessed, developed, effectively implemented, etc.), Equipment fit for purpose (rated, designed compatible, maintained, inspected, monitored, etc.)

Leadership (communication, directions, monitoring, etc.),

Environmental conditions are compatible to the operational capabilities of the equipment (natural vs. manmade, etc.),

Inclusions

Only the aspects directly related to Solidsvac SV150 Mobile Solids Pump

Exclusions

Transporting and storing the Solidsvac SV150 Mobile Solids Pump (Users operational risk assessment, training, competence);

Assessment of the environmental conditions in the operational area (Users planning and local risk control),

Reference Material

QLD Coal Mining Safety & Health Act 1999

QLD Coal Mining Safety & Health Reg 2001

Recognised Standard 02 Control of risk management practices

Risk Matrix

Step 1 : Establish the Consequence (1-5)						
Consequences		Injury / Occupational Illness or Disease <small>(How to manage Work Health and Safety Risk - Code of Practice. Safety Work Australia 10 August 2011) The company must ensure levels of consequence and likelihood are relevant to the company's business risk)</small>	Business Loss / Asset Damage	Reputation / Social / Community	Legal and Regulatory / Contract	Environmental Impact <small>(eg Hydrocarbon spills)</small>
1	Insignificant	Report only	<\$5k	Complaint / Single project or stakeholder	Minor non-compliance - internal report only	Negligible pollution
2	Minor	First Aid Treatment Injury/Illness - Non-prescription medication / treatment that can be administered by first aider.	<\$20k	Local public concern	Minor legal non-compliance / Contractual issue	Minor pollution / Nuisance
3	Moderate	Medical Treatment Injury/Illness - Prescription medication / treatment that can only be administered by registered doctor/nurse. Minor LTI <5 full days work lost	<\$50k	Regional public concern / Multiple stakeholders	Serious breach of law / Investigation by authority / On the spot fine. Major breach of contract.	Noticeable pollution
4	Serious	Serious Lost Time Injury/Illness - Loss of 5 or more days work / admission to hospital / Serious injury under WHSA definition.	<100k	National public concern	Significant penalties / Termination of contract.	Significant environmental event
5	Major	Fatality - Single or multiple fatalities	<\$100k	International public attention	Law suits / Prosecution / Removal from suppliers list	Major environmental event / Material environmental harm

Step 2 : Establish the Likelihood (A-E)		
Description		Frequency Examples <small>(How to manage Work Health and Safety Risk - Code of Practice. Safety Work Australia 10 August 2011)</small>
A	Certain to occur	Expect to occur in most circumstances (>1 event / month)
B	Very likely	Will probably occur in most circumstances (2 to 1 events / year)
C	Possible	Might occur occasionally (1 event / 1 to 2 years)
D	Unlikely	Could happen at some time (1 event / 2 to 3 years)
E	Rare	May happen only in exceptional circumstances (>3 to 5 years)

Step 3 : The Hierarchy of Risk Control Model

Start at the top and only if you can't select controls from one section, move to the next one down. You need to use a combination of control measures to achieve the second level of risk control. If a particular hazard can't be removed the risk associated with the hazard can never be eliminated.

1	Elimination	Complete removal of the hazard	
2	Substitution	Replacing the material of process with a less hazardous one.	
3	Isolation	Separate the hazard from people.	
4	Engineering	Guarding, ventilation, design, re-design etc.	
5	Administration	Providing controls such as training and procedures.	
6	PPE	Use of PPE when other controls are not practical	Least effective
7	Post	Mitigation after an event (eg. Fire extinguisher)	

Using the Matrix to Determine Risk Score

Likelihood	Consequences				
	1	2	3	4	5
A Certain to occur	Low 11	Moderate 16	Moderate 20	High 23	High 25
B Very likely	Low 7	Low 12	Moderate 17	High 21	High 24
C Possible	Low 4	Low 8	Moderate 13	High 18	High 22
D Unlikely	Low 2	Low 5	Moderate 9	Moderate 14	High 19
E Rare	Low 1	Low 3	Low 6	Moderate 10	High 15
ALARP - As Low as Reasonably Practical					
Tolerable	Take action to manage ALARP		Intolerable (without specific senior management approval)		

Risk Assessment assumes that current controls are adequate and working.
The Risk Scores have been achieved using the qualitative risk analysis matrix from the Solidsvac Risk Management procedure and is attached at the end of this document.



Operational Risk Assessment

REFERENCE	ACTIVITY	SUB ACTIVITY	HAZARD	RISK EVENT	EXISTING CONTROLS	CURRENT RISK WITH EXISTING CONTROLS			RISK TREATMENT(Accept, Transfer, Avoid, or Further Risk Review)	ADDITIONAL RECOMMENDATIONS	STATUS (Complete, Incomplete, In progress)	TARGET RESIDUAL RISK AFTER TREATMENT
						CONSEQUENCE	LIKELIHOOD	RISK RATING				
1.0	Transport to work site	Travel position	Inadequate transport method	Resulting in personal injury and damage to the Solidsvac SY20 Mobile Solids Pump during transport.	Wheels and handle on the Solidsvac SY20 Mobile Solids Pump Designed well balanced Mine transport rules			L8	Placement and loading of the Solidsvac SY20 Mobile Fluids Pump to be included in the training and assessment document in the Solidsvac SY20 Mobile Solids Pump	Open		
1.1	Set up		Solidsvac SY20 Mobile Solids Pump set up on uneven ground or pump is inadequately secured to rib when on uneven ground resulting in Unplanned movement of pump	Resulting in personal injury and damage to the Solidsvac SY20 Mobile Solids Pump during operation	Operation manual and training documents set up procedure on level ground or securing pump to the rib using rated restraining devices when operating on uneven ground	2	C	L8	Training and assessment in the Solidsvac SY20 Mobile Solids pump package			
			Manual handling	Failure of the correct manual handling technique	Manual handling training at Induction team lifts where required Most set up and removal tasks conducted from floor level and reasonable height	2	C	L8	Training and assessment in the Solidsvac SY20 Mobile Solids pump package			
			Nip/crush points and "Line of Fire" issues from mobile equipment, low roof height issues during set up and removal resulting in crush injury's	Resulting in personal injury	Operation manual and training documents setup, removal procedures identifies the need to drain pump before disconnecting, Mine transport rules Line of sight before any movements No machine movements without positive communications H4 - viz clothing	3	C	M13	ALARA			
			High pressure compressed air	Failure of the compressed air system resulting in: Personal injury from being exposed compressed air due to hose failure and / or damage;	Rated pressure hoses Mine Site Induction and Training Competencies	3	C	M13	ALARA			
			Work on or around a moving belt	Interaction with conveyor resulting in personal injury	Mine Site Induction and Training Competencies	2	C	L8	ALARA			
			Discharged material (at 100psi) contacts operators	Resulting in personal injury	Operation manual and training documents the set up procedure incorporates barricading discharge area with caution tape	2	C	L8	ALARA			
			Pinch points on Solidsvac SY20 Mobile Solids pump during operation	Resulting in personal injury	Fit for purpose covers fitted to pump during operation, must be in place	2	C	L8	ALARA			

1.2 Operation

Reviewed by

Date

REFERENCE	ACTIVITY	SUB ACTIVITY	HAZARD	RISK EVENT	EXISTING CONTROLS	CURRENT RISK WITH EXISTING CONTROLS			RISK TREATMENT(Accept, Transfer, Avoid, or Further Risk Review)	ADDITIONAL RECOMMENDATIONS	STATUS (Complete, Incomplete, In progress)	TARGET RESIDUAL RISK AFTER TREATMENT
						CONSEQUENCE	LIKELIHOOD	RISK RATING				
			Blocked discharge hose resulting in exposure to stored energy while unblocking hose	Resulting in personal injury	Operation manual and training documents unblocking procedure Pressure relief valve at the pump relieves discharge pump pressure	2	C	L8	ALARA			
			Blocked suction hose resulting in process delay	Resulting in personal injury and or process delay	Operation manual and training documents unblocking procedure Isolation training and procedures Low pressure: 4Dpsi Strainer or nozzle fitted to suction hose	2	C	L8	ALARA			
			Friction generated static discharge.	Resulting in personal injury and or process delay	Fras or bonded hoisting used for Suction, Discharged and Air Supply, Ear bond point installed on equipment, fit for purpose.	2	D	L5	ALARA	OEM recommends a specific Risk Assessment to be conducted to identify friction egenerated static discharge.		
1.3	Maintenance		Incorrect maintenance resulting in equipment failure	Resulting in personal injury and or process delay	Tested to Australian Standards, OEM Maintenance scheme	2	C	L8	ALARA	Maintenance to be carried out as per OEM Suppliers SV20 Operation/Maintenance Manual		
RISK REGISTER ACTION PLAN												
No	ITEM/ISSUE	AGREED ACTION			Who	When	Comp Date	Review / Audit				
	Storage	Communicate to end user to develop work procedures for storage of Solidsvac SV20 Mobile Fluids Pump			Solidsvac	Delivery						
	Travel position	Communicate to end user to develop work procedures for travelling			Solidsvac	Delivery						
	Operation	Use of Solidsvac SV20 Mobile Fluids Pump	Supplier to develop work procedures for operating the Solidsvac SV20 Mobile Solids Pump			Solidsvac	Delivery					
		Daily	Supplier to develop daily and or pre-use visual inspections procedures for using and operating the Solidsvac SV20 Mobile Solids Pump			Solidsvac	Delivery					
	Maintenance	Weekly	Supplier to develop weekly visual operational maintenance inspections for using and			Solidsvac	Delivery					



Pump Maintenance Checklist

Description	Comment	Maintenance Frequency			
		Daily	Weekly	Monthly	Annually
Pump use and timing	Check operation of pump prior to use	X			
Overall visual inspection	Complete overall visual inspection to be sure all equipment is operating and safety systems are in place.	X			
Check ball valve seals	Assure that all seals are in good condition and not worn, split or damaged .		X		
Check exhaust box	Check exhaust box for foreign material and clean as necessary.		X		
Check airlines and fittings	Inspect airlines for any deterioration, check fittings for cracks and leaking		X		
Check bolts	Check and secure all clamps and bolts		X		
Check in-line gauze filter	Check in-line filter for cleanliness and obstructions. Clean as necessary		X		
Check Venturi nozzle and PRV	Check the condition of the venturi nozzle. Check operation of the PRV			X	
Pressure Vessel Inspection	Inspect the vessel for wear, cracks and/or damage.				X
Full Service and PRV	Conduct a full service on the pump and replace the PRV				X



Pump Preventative Maintenance Program

**The Following is the Work to be Performed to a SV150-CVCD Pump
During Preventative Maintenance Check**

**All Items, except annual checks(Tradesman), are to be carried out by a
Competent Operator**

- Lock and tag out equipment
- Record equipment data
- Check all mounting bolts and clamps are secure and tight
- Check vessel support frame and wheels for soundness
- Visual inspection of pump for any damage
- Check exhaust box for cleanliness(if fitted).
- Check condition of seals
- Check 2 way ball valve for leakage.
- Make sure all timers are operational
- Check operation of Pressure Relief Valve
- Check in-line gauze filter
- Inspect condition of airlines and fittings
- Check operation of swing check valve (if fitted)
- Check condition of venturi nozzle
- Test the operation of the SV150-CVCD pump prior to returning to service.
- Make note on the field report of any findings that may require additional work

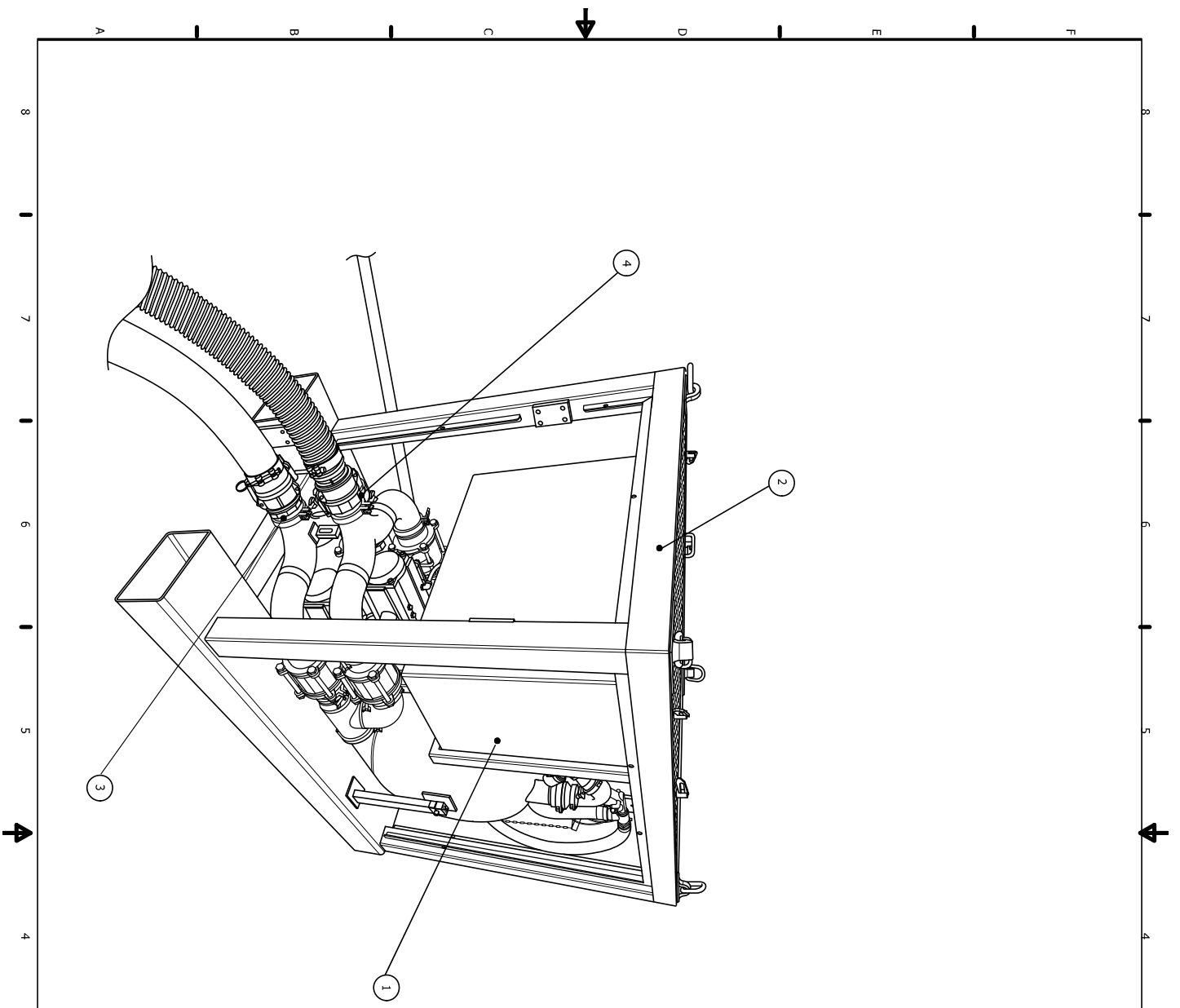

PARTS LIST	
ITEM	DESCRIPTION
SV150-5	EXHAUST BOX ASSEMBLY
SV150-1	CRASH FRAME ASSEMBLY
SV927-A	4" CAMLOCK TYPE A
SV927-B	4" CAMLOCK TYPE B

DRAWN		12/12/20		
MS		12/12/20		
CHECKED		J. KROHN		
QA		12/04/21		
MFG				TITLE
APPROVED		M. KROHN		SV150-CVCD-01
				SIZE
				A4
				DWG NO
				SCALE
				1:1
				REV
				1,1

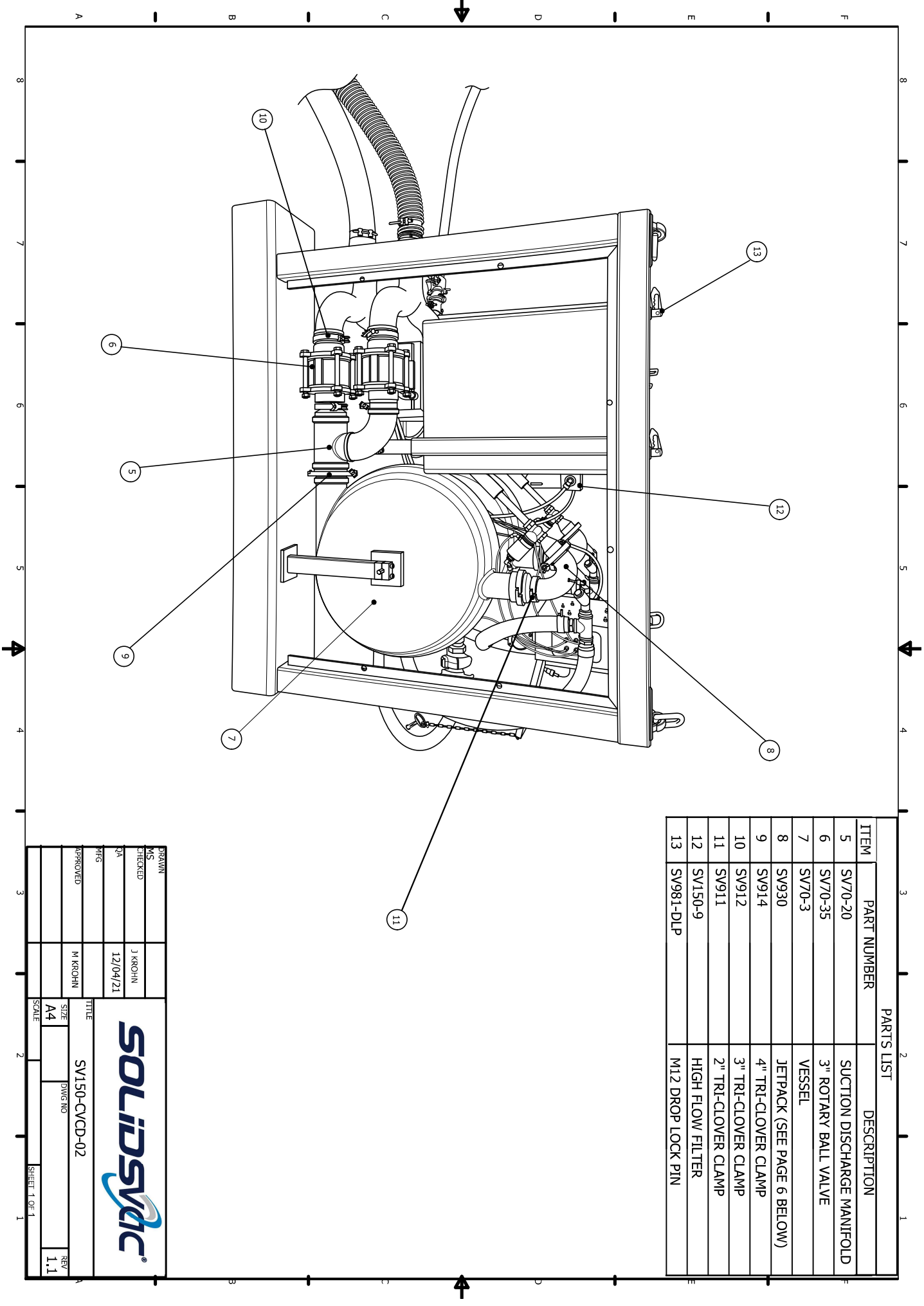

ITEM	PART NUMBER	DESCRIPTION
5	SV70-20	SUCTION DISCHARGE MANIFOLD
6	SV70-35	3" ROTARY BALL VALVE
7	SV70-3	VESSEL
8	SV930	JETPACK (SEE PAGE 6 BELOW)
9	SV914	4" TRI-CLOVER CLAMP
10	SV912	3" TRI-CLOVER CLAMP
11	SV911	2" TRI-CLOVER CLAMP
12	SV150-9	HIGH FLOW FILTER
13	SV981-DLP	M12 DROP LOCK PIN

PARTS LIST		TITLE	
DRAWN			
MS			
CHECKED	J. KROHN		
QA	12/04/21		
YMG		APPROVED	M. KROHN
TITLE		SIZE	DATE
SV150-CVCD-02		A4	
SCALE		REV	
1:1		1.1	

PARTS LIST	
ITEM	DESCRIPTION
14	SUCTION MANIFOLD
15	DISCHARGE MANIFOLD
16	ACTUATOR BRACKET AND RBV ARMS
17	ACTUATOR

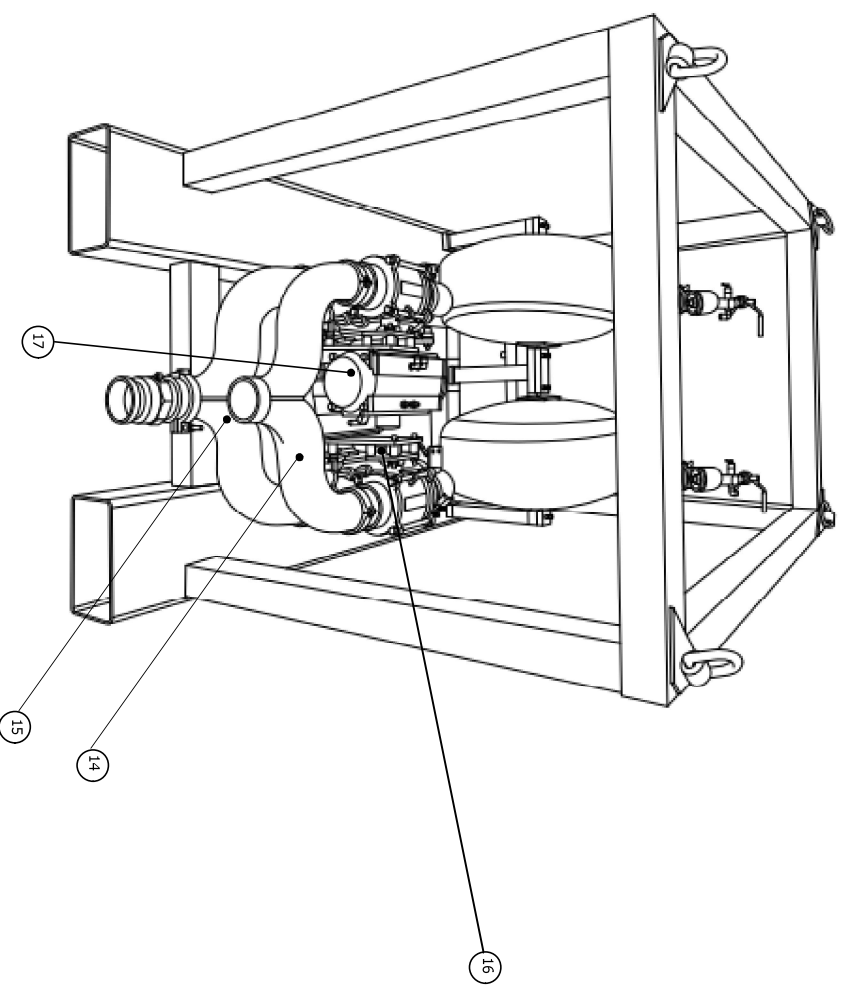

DRAWN				
CHECKED	J. KROHN			
QA	12/04/21			
MFG				
APPROVED	M. KROHN			
TITLE		SV150-CVCD-03		
SIZE	A4	DWG. NO.		REV
SCALE				1.1

SOLIDSVAIC

SHEET 1 OF 1

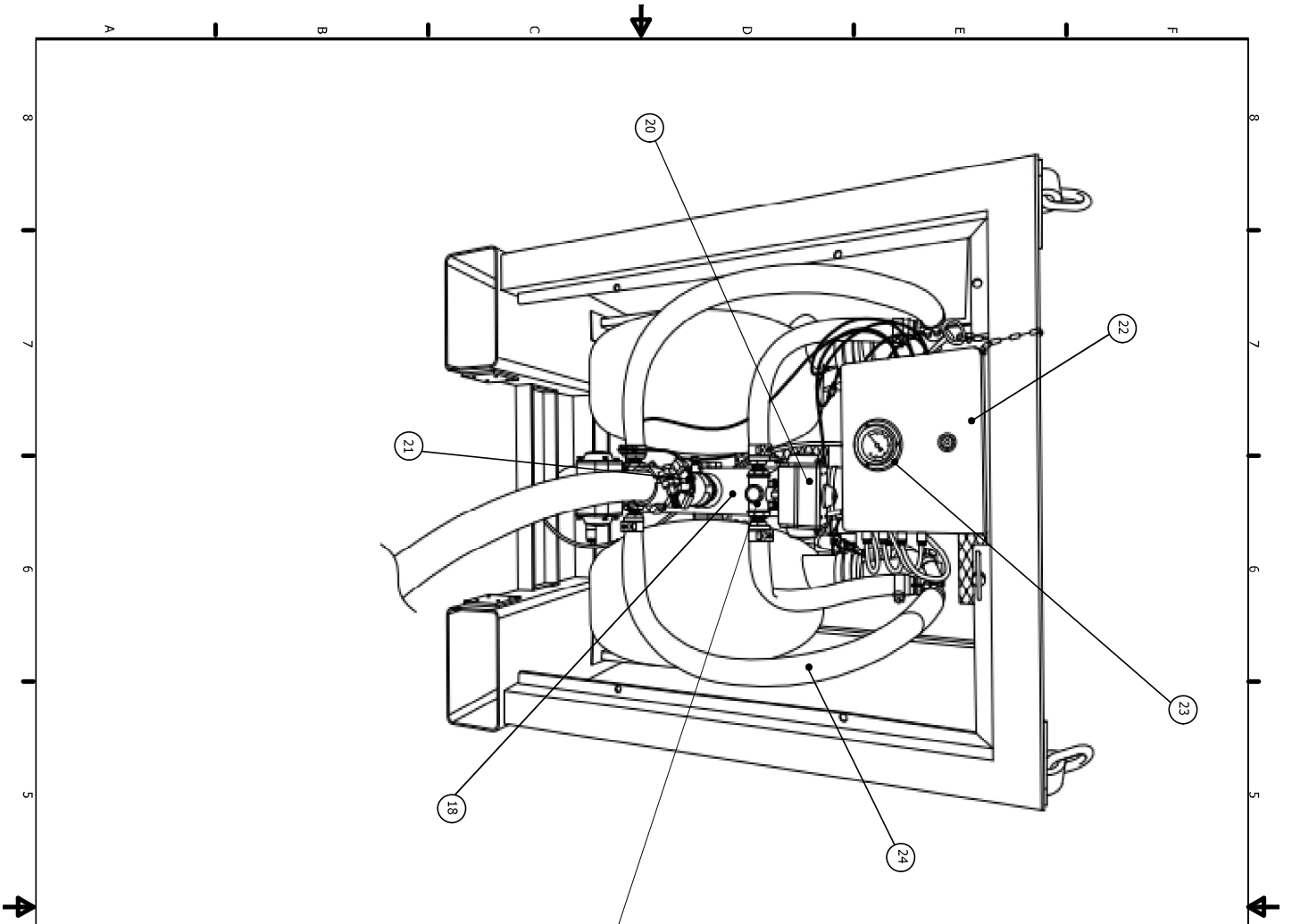

ITEM	PART NUMBER	DESCRIPTION
18	SV150-8	ACCUMULATOR
19	SV150-7	3 WAY BALL VALVE
20	SV150-7-1	1" ACTUATOR
21	SV200-21	1 1/2" CLAW COUPLING
22	SV150-2	CONTROL BOX (SEE PAGE 5 BELOW)
23	SV200-15	PRESSURE GAUGE
24	SV150-13	1" AIR HOSE
22	SV150-CVCD-SK	SERVICE KIT
22	SV150-10	FITTINGS KIT
23	SV150-11	TUBING KIT
24	SV150-12	SAFETY DECAL SET

		TITLE SV150-CVCD-04	
DRAWN MS	CHECKED QA	J KROHN 12/04/21	M KROHN
APPROVED	SIZE A4	DWG NO.	REV 1.1
SCALE		SHEET 1 OF 1	

PARTS LIST	
ITEM	DESCRIPTION
1	50/100CFM VENTURI HOUSING
2	50/100CFM NOZZLE MANIFOLD
3	50CFM VENTURI NOZZLE
4	50/100CFM DIFFUSER CONE
5	50/100/180CFM DIFFUSER VALVE
6	50/100CFM DIFFUSER STEM
7	1/2" LOCK NUT
8	1/2" BALL VALVE (LOCKABLE)
9	1/4" PRV

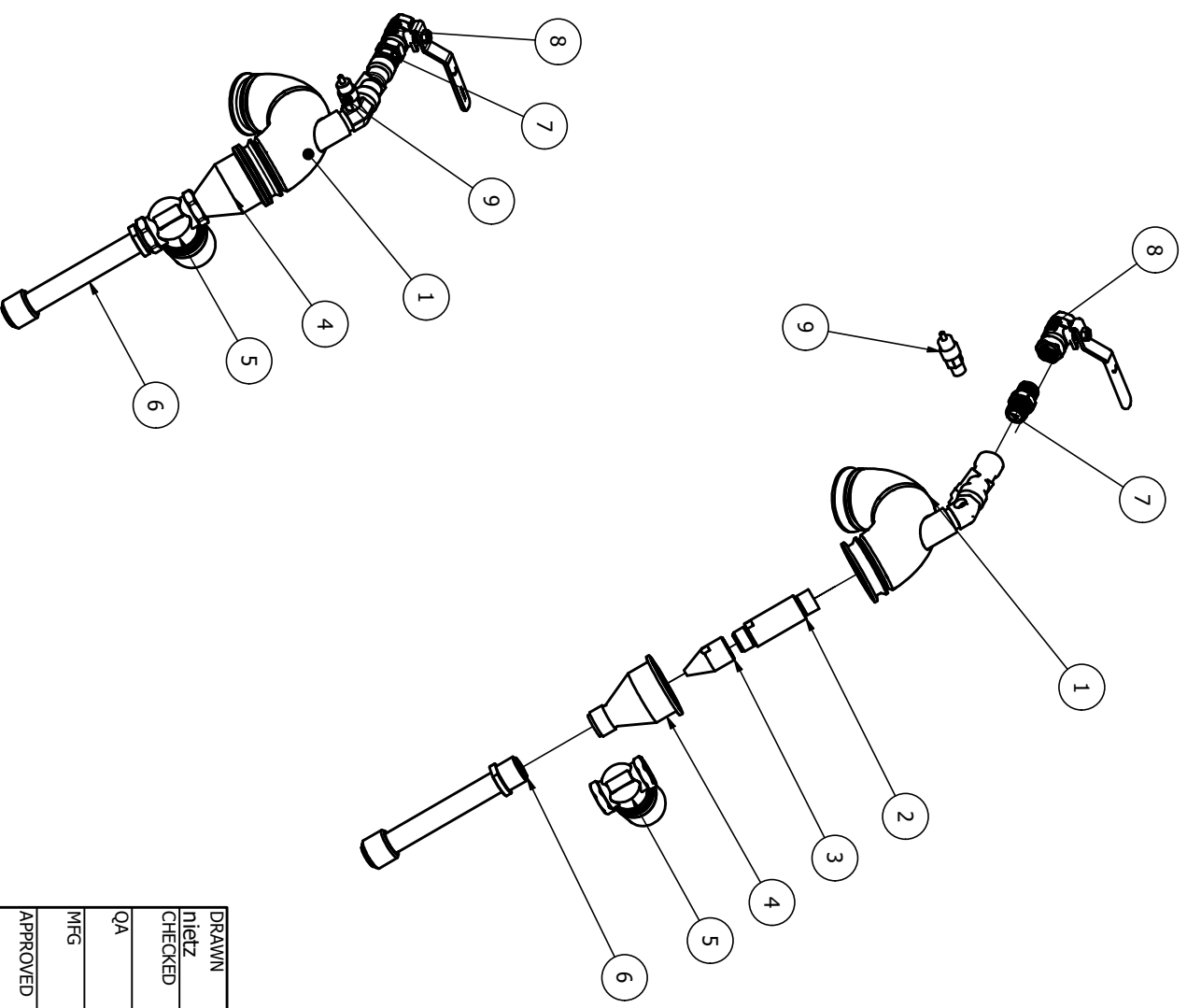

DRAWN	nietz	9/18/2019	TITLE	SV929 50CFM JETPACK - EXPLODED	
CHECKED		J KROHN	SIZE	A3	REV
QA		12/04/21	DWG NO	SV929	1.1
MFG			SCALE	1 / 5	
APPROVED		M KROHN	SHEET 12 OF 49		



JOB SAFETY ANALYSIS

Note: It is recommended that a site specific JSA is conducted prior to operation of the unit.



Job Safety Analysis – Solidsvac SV150-CVCD Slurry Pump

Date Of Audit – June 2020.

Equipment/Task: Set-up and Operate Solidsvac Solids/Slurry Pump.

Note: Site Safety requirements must be adhered to at all times. Personal Protective Equipment including approved safety eyewear and hearing protection are to be worn at all times whilst operating this equipment.

Step #	Job Steps	Hazards/What Can Go Wrong	Controls & Risk Reduction
1	Selecting the Right Pump	Selecting the incorrect pump/equipment to transfer media that is either hazardous in itself or becomes hazardous when transferring can result in delay of operating and injury.	Site specific JSA must be conducted prior to operation to identify site specific media risks & hazards.
2	Siting the pump.	The pump may be unstable.	Site the pump on a reasonably flat, level & stable surface, or on a suitable straddle frame.
3	Connecting discharge hose range to pump.	(a) Use of inappropriate non pressure rated discharge hose, hose or couplers may cause discharge hose range failure. (b) Sharp bends, tee pieces and valves in a discharge line can cause blockages	Ensure minimum 2" discharge range is used rated to 10Bar. Hose may be rubber or poly. The pump utilises the camlock coupling system. Use Solidsvac supplied FRAS rubber Stainless Steel camlock ended pressure rated hose ass'y to enable safe connection. Ensure discharge hose range has no sharp bends or tee pieces and is free of restrictions such as reductions in hose diameter or gate valves etc.

Job Safety Analysis – Solidsvac SV150-CVCD Slurry Pump

Note: Site Safety requirements must be adhered to at all times. Personal Protective Equipment including approved safety eyewear and hearing protection are to be worn at all times whilst operating this equipment.

Step #	Job Steps	Hazards/What Can Go Wrong	Controls & Risk Reduction
		(c) Discharge hose range may move particularly at discharge exit point.	Ensure discharge hose range is secured at appropriate points along its length and particularly at discharge exit point..
4	Connecting the suction hose to the pump.	Sharp bends, tee pieces and valves in a suction hose can cause blockages	Wear eye and hearing protection. Hold hose firmly. Ensure suction hose range has no sharp bends or tee pieces and is free of restrictions. Ensure suction hose couplings are correctly engaged and have safety clips fitted.
5	Connecting the air supply hose to the pump. Air hose should be blown clean before connection.	(a) Compressed air can be dangerous and may cause injury. Blowing air supply hose clean can cause eye, hearing or physical injury if not carried out in a controlled manner.	Ensure air hose is turned off completely and that the pump air inlet ball valve is closed before connection.
		(b) Air supply hose can 'fly off' if not properly connected.	Ensure air line couplings are correctly engaged and have safety clips fitted.



Job Safety Analysis – Solidsvac SV150-CVCD Slurry Pump

Note: Site Safety requirements must be adhered to at all times. Personal Protective Equipment including approved safety eyewear and hearing protection are to be worn at all times whilst operating this equipment.

Step #	Job Steps	Hazards/What Can Go Wrong	Controls & Risk Reduction
6	Pump Operation – Unblocking Suction Hose or Suction Wand.	Reverse flushing of suction hose or suction wand nozzle with high pressure water hose can result in eye injury.	If disconnecting suction hose or suction wand – stop the pump. Wear approved eye protection
7	Pump Operation – Unblocking Discharge Hose Range Blockages.	Pressure in discharge range has potential to cause eye and physical injury.	STOP THE PUMP. DO NOT DISCONNECT ANY DISCHARGE HOSE RANGE COMPONENT WHILST PUMP IS OPERATING. Depressurise the discharge hose range by operating a manual pressure relief valve on the pump or within the hose range (if fitted) OR, using EXTREME CAUTION, loosen hose couplings upstream of the estimated blockage point (ie. between pump and blockage) to safely vent residual pressure before attempting to fully open hose joints to clear the blockage.

Step #	Job Steps	Hazards/What Can Go Wrong	Controls & Risk Reduction
8	Pump Operation – Discharge Hose Range Exit Point.	Injury can be caused by high velocity material ejected from discharge point.	Do not stand in front of the discharge hose range exit point. Minimise risk by directing this point away from traffic zones. Use Solidsvac supplied Dead Head/Drop Box to reduce velocity & control material at discharge point.
9	Disconnecting Pump from Air Supply	Injury may result from uncontrolled whipping of pressurised air hose.	Before disconnecting air hose isolate it upstream & open the Pump Air Supply Ball Valve to release residual pressure from the air line.

Model Number

Serial Number

Date of Manufacture

Inspected by



201 First Avenue - Bribie Island - QLD 4507 - Australia

+61 456 000 665 | info@solidsvac.com

www.solidsvac.com