

# SOLIDSVAC<sup>®</sup>

SOLIDS PUMPING SYSTEMS



## SV70-SPDK Operations Manual



U1/ 5-7 Boeing Place - Caboolture - QLD 4510 - Australia

+61 456 000 665 / [info@solidsvac.com](mailto:info@solidsvac.com) / [www.solidsvac.com](http://www.solidsvac.com)

## CONTENTS

Description	Page
Safety First	3
1. Operation Overview	3
2. Design Registration	3
3. Technical Data	4
4. Schematic	4
5. Pump Set-Up	5
6. Operation	6
7. Maintenance	7
8. Timer Cycling & Adjustments	11
9. Accessories	12
10. Operation Risk Assessment	13
11. Parts Assembly	21
12. Job Safety Analysis	24



**SCAN ME**

Scan this QR Code for an electronic version of this Operations Manual

## SAFETY FIRST

### CAUTION & GENERAL SAFETY

This manual contains important information concerning the installation, operation and maintenance of the Solidsvac Pump, Model SV70-SPDK. To prevent injury to personnel or equipment damage, this manual MUST be read and understood by those responsible for the installation, operation and maintenance of the equipment.

**THIS OPERATION MANUAL MUST BE USED IN CONJUNCTION WITH BOTH SITE-SPECIFIC RA AND JSA'S.**

- Isolate, tag out and disconnect the air supply to the unit prior to working on any part of the system
- Lift the equipment only at the lifting points provided
- The pump should be installed in a safe level area, which provides adequate access for operating the equipment
- Ensure all hoses are in good condition, correctly rated and certified for the service in which they are to be used
- Inspect the unit regularly for damaged or worn components
- All covers MUST be fitted prior and during operation
- Air pressure should NEVER exceed rated pressure
- Tie down points (if fitted) MUST NOT be used as lifting point

### CAUTION: BE AWARE OF RETAINED MATERIAL IN THE TANK INCREASING WEIGHT

**SOLIDSVAC PUMPS EACH HAVE SPECIFIC COMPRESSED AIR REQUIREMENTS DEPENDING ON THE JET PACK FITTED.**

The operator MUST ensure that an appropriate and adequate air supply is available depending on the model and Jet Pack in use. All Solidsvac Pumps require a minimum operating pressure of 500kPa and have a maximum operating pressure of 720kPa (105psi). It is recommended that a 25mm (1") i.d. air hose is used for compressed air supply to the pump.

**Note: An 18mm (¾") i.d. Air hose contains HALF the volume of the recommended 25mm (1") hose.**

The Discharge hose MUST be no smaller in diameter than the pumps outlet 75mm (3") preferably a self-supporting type and secured at regular intervals.

### WARNING: THE PUMP-OUT LINE MUST BE SECURED AT THE EXIT POINT

## 1. OPERATIONAL OVERVIEW

The Solidsvac SV70-SPDK operates as a shuttle system alternately loading via vacuum and discharging via pressure a wide range of flowable and semi-flowable materials.

Operation is fully automatic and the Solidsvac SV70-SPDK features no internal workings, high vacuum and pressure discharge where suction of up to 50 metres and discharges in excess of 400 metres are achievable.

### WARNING

Compressed air can be dangerous. Correctly rated hoses and piping should be used in conjunction with the appropriate fittings and safety devices on all connections.

The unit is not designed to operate above 758kPa (114psi) and the PRV will relieve at 758 +/- 35kPa (110psi +/- 5psi).

## 2. DESIGN REGISTRATION

The Solidsvac SV70-SPDK has a Certificate of Plant Design Registration from Workcover NSW, Australia. A copy of which may be obtained by contacting Solidsvac Pumps.

**DESIGN REGISTRATION # PV-6-198163/16**

### Technical Standards

- AS2971-2007 Serially Produced Pressure Vessels
- AS4343-2005 Pressure Equipment - Hazard Levels
- AS1210-1210 Pressure Vessels

### 3. TECHNICAL DATA

TECHNICAL DATA	METRIC	US IMPERIAL
Height	1150 mm	45"
Width	650 mm	25.5"
Length	1240 mm	48.5"
Weight	130 kg	264 lb
Air inlet	13 mm	1/2" BSP
Suction inlet	75 mm	3"
Discharge outlet	75 mm or 100 mm	3" or 4"
Suction lift	7.9m @ 100 cfm 9.2m @ 180 cfm 11.5m @ 230 cfm	26' 2" @ 100 cfm 30' @ 180 cfm 37' 7" @ 230 cfm
Air consumption options	2.8 m <sup>3</sup> /Min Jet Pack 5.0 m <sup>3</sup> /Min Jet Pack 6.5 m <sup>3</sup> /Min Jet Pack	100 cfm Jet Pack 180 cfm Jet Pack 230 cfm Jet Pack
Delivery	400+ m	1312+ ft
Displacement cycle	65 ltr	17 gal
Operating pressure	7 bar (max) @ 690 kPa 4.5 bar (min) @ 448 kPa	100 psi (max) 65 psi (min)
Maximum solids	50 mm	2"
Measured water throughput	400 lpm	106 gpm

### 4. SV70-SPDK SCHEMATIC

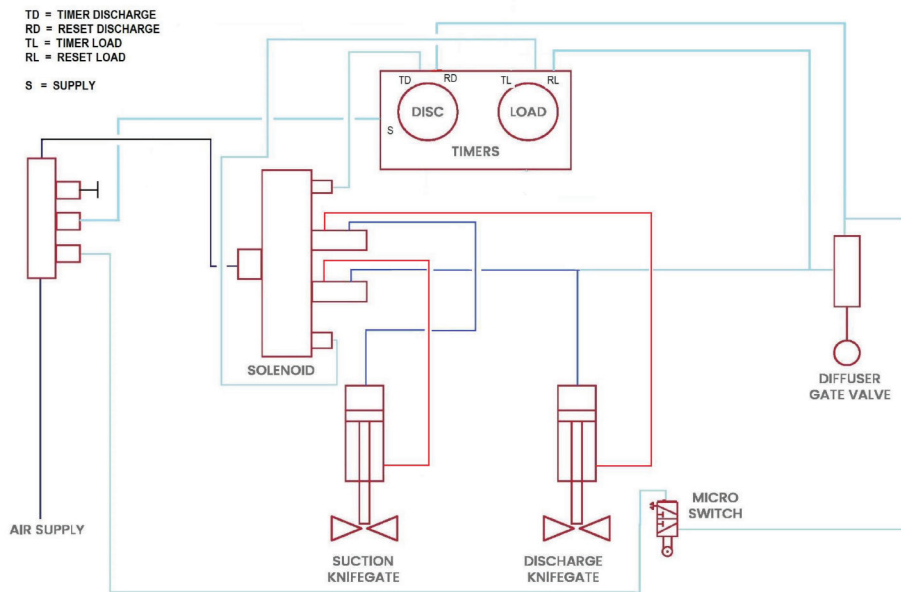

SV70-SPDK SCHEMATIC

## 5. PUMP SET-UP

Before commencing operation, Solidsvac strongly recommends each user reads the Operation Manual supplied with each unit and available online or via the QR code on pump.

**Note: No training is necessary to operate the SV70-SPDK however understanding the Operations Manual is essential to safe practice.**

Solidsvac also recommends that a site-specific Risk Assessment (RA) of the pumping operation is undertaken. Any recommendations arising from the Risk Assessment would be additional to the following:

- The unit and all hoses and fittings are undamaged and in good working order.
- All covers are fitted in place and correctly secured.
- Clean compressed air at minimum working pressure of 690kPa (100 psi) is available.
- A 25mm (1") i.d. air hose is available.
- The discharge area has suitable warnings to protect personnel.
- The correct PPE is available and worn for operating compressed air equipment
  - Eye Protection
  - Hearing Protection
  - Gloves
  - Safety Boots
- Set the Solidsvac Pump in a safe level location as close to the material to be pumped as possible.
- Attach both suction and discharge hoses along with any accessories as required and ensure safety clips are in place.
- Ensure the main air valve is in the off position and attach the 25mm (1") air hose to the Solidsvac Pump & fit safety clips.
- The pump is now ready for use.

**Note: Always position hoses out of walkways where possible remaining aware of trip and fall hazards.**

## CONTENTS EXCLUDED FOR PUMPING

Solidsvac recommends that any contents that fall within the scope of the below class liquids should not be pumped with any Solidsvac unit. Solidsvac also recommends that a site-specific JSA should be conducted with reference to any other type of material being pumped.

- Class IIIA liquids with a flash point equal to or greater than 140 °F (60 °C), but less than 200 °F (93 °C) have a NFPA 704 flammability rating of 2.
- Class IIIB liquids with a flash point equal to or greater than 200 °F (93 °C) have a NFPA 704 flammability rating of 1.

## OPERATING PARAMETERS

The Solidsvac SV70-SPDK can operate within environments ranging from 0 °C to 50 °C and all humidity.

The maximum medium temperature allowable for the SV70-SPDK is 50 °C.

## HOSES

Solidsvac recommends the hoses (Air Supply, Suction, Discharge) used in operation with the SV70-SPDK are to be made of anti-static material. If the hoses used in operation with the SV70-SPDK are not made of anti-static material, they MUST be braided to comply with requirements for Fire Resistance & Anti-Static (FRAS) to AS/NZS 2660, or other equivalent standard.

## EARTHING POINT

All Solidsvac models are fitted with an Earthing Point which is mandatory requirement prior to operation. Solidsvac strongly recommends that the operator takes the necessary measures to earth the unit prior to operation.

**WARNING: TO AVOID POSSIBLE ELECTROSTATIC CHARGES PRODUCED BY THE MATERIAL CONVEYED THE OPERATOR MUST EARTH THE UNIT PRIOR TO OPERATION.**

## 6. OPERATION

Turn the air supply valve ON at the source. Turning the pump valve to ON, the pump will now commence its cycle of operation. The LOAD and DISCHARGE cycles are controlled by adjustable pneumatic timers, these allow for adjusting the pump to varying conditions, i.e. heavy or light material or long or short distances etc. During the LOAD cycle the operator should note an audible difference (Gargle) once the vessel has filled, adjust the LOAD timer to where the cycle completes just as or prior to this occurring. The DISCHARGE cycle depends on both the material being transferred and the distances involved. A discharge setting of 4-6 seconds will accommodate about 95% of most pumping jobs with the SV70-SPDK.

Once pumping is completed, remove the suction from the material and allow the pump to cycle self-clean, on completion of the operations isolate the air supply and allow the pump to cycle until the supply in the line is exhausted, then turn the pump off at the supply line. SOLIDSVAC recommends checking the pump discharge to ensure it remains correctly anchored at the exit. Lubrication is not required during operation.

**Note: Dry operation will not damage the pump.**

### CYCLE INDICATOR

The pump is fitted with an indicator to inform the operator which cycle the pump is operating in, when in the discharge cycle the indicator is yellow and when in the suction cycle the indicator is clear.

**Note: If the pump is supplied with a head of pressure it is possible for the pump to siphon when the air supply is turned off. To prevent siphoning when the pump is not in operation, turn the pump off when it is in the discharge cycle or isolate the material supply source to the pump.**



**DISCHARGE CYCLE INDICATED**



**SUCTION CYCLE INDICATED**



**EARTHING POINT**

An earthing point is fitted to the SV70-SPDK if required by the site-specific RA or JSA.

## 7. MAINTENANCE

In use, the Solidsvac SV70-SPDK requires little to no maintenance, however Solidsvac recommends that the following strict measures are taken to ensure pump remains in good working order.

Maintenance, repairs, and the disassembling of the unit be carried out by any qualified Fitter with a basic knowledge of pneumatics.

### SERVICE TIPS

- Set up a maintenance schedule and follow it diligently.
- Clean the machine areas before removing pneumatic components.  
**Note: When steam cleaning or using water to clean a machine, be sure that filler openings, breather caps etc are protected from possible entry of water into the system.**
- Use clean plastic plugs to cover the ends of disconnected lines or to plug openings when working on a pneumatic system.
- A clean workbench is an absolute 'MUST' when servicing components. An industrial-type vacuum cleaner is a valuable aid in removing dust, dirt and tiny metal particles from the work area.
- Check the condition of your tools – they should be clean. Always use hammers made of plastic or leather, so there is no danger of metal chips getting into components.
- When removing parts for service, clean them and then store them in plastic bags or other clean containers until they are installed again.
- When cleaning pneumatic parts, use extreme care to ensure that the cleaning fluid is non-flammable and compatible with the system.
- Use common-sense precautions to prevent dirt entering components that have been temporarily removed from the circuit.

### SYSTEM PERFORMANCE

Pneumatic problems that affect system flow and pressure are not always easy to locate. The system testing procedure described later in this section is based on a useful step-by-step approach to troubleshooting. Troubleshooting charts make the fault-finding process easier and faster.

### EFFECTS OF A DROP IN SYSTEM FLOW RATE

- A pressure drop will affect the speed and cycle times of a pneumatic machine; actuators will not extend, retract, or rotate at the required speed. Actuator control will become jerky with inconsistencies in flow as cylinders and motors are supplied at different rates. In many complex pneumatic systems, the sequencing and positioning of component operations will be affected as cycle times become thrown out of programmed control.
- The compressor's discharge flow rate should be checked first to ensure that the drop in flow is not a problem of internal leakage or incorrect setting of compressor controls.

### EFFECTS OF DROPS IN PRESSURE

The major causes of pressure drop include:

- Pipework restrictions (for example, incorrect sizing) fitting restrictions and sharp corners
- Incorrect pressure settings
- Sudden enlargement in fluid conductors
- Long lengths of fluid conductors
- Component leakage (internal and external)
- Broken valve springs
- Blocked or crimped air lines
- Loose fittings
- Valves not sealing correctly because of contaminants
- Some combination of the above causes

## **SYSTEM TESTING PROCEDURES**

Pneumatic systems, like all machines, require routine maintenance to ensure reliability. However, there are still times when problems occur and **MUST** be located quickly and efficiently, especially in production applications. A step-by-step method has been devised as a way of finding and solving pneumatic problems quickly.

These steps are as follows:

### **STEP 1: KNOW THE SYSTEM –**

Study the machine's technical specifications to obtain an understanding of how the system operates and the function of the machine's components. Obtain a circuit drawing and check the system through. Check the machine's maintenance records and commissioning test results if they are available.

### **STEP 2: ASK THE OPERATOR –**

Determine the symptoms of the problem by asking the operator for a detailed description of the machine's normal operating performance.

### **STEP 3: INSPECT THE MACHINE –**

Use your senses (touch, smell, sight and hearing) to locate problems or damage such as noisy components, air leaks, malfunctioning components and damaged air lines.

### **STEP 4: OPERATE THE MACHINE –**

Operate the machine and check that the machine's gauges are reading 'normal' and that there are no unusual noises. The operation of the machine's controls should not be 'sticky' or 'spongy'. The machine's performance should not be slow, erratic – nor non-existent.

### **STEP 5: LIST THE POSSIBLE CAUSES –**

Once the fault has been located and recognised, list the possible causes – starting with the simplest.

### **STEP 6: REACH A CONCLUSION –**

Use a troubleshooting chart to check the list of possible causes; then decide which is the most likely.

**Note: 99% of all issues are air supply related.**



## SYSTEM MAINTENANCE

A pneumatic system is easy to maintain. However, like any other mechanism, it MUST be operated and maintained correctly. Pneumatic systems can be damaged by excessive pressures, fluid contamination and by high operating temperatures.

Regular maintenance will reduce your pneumatic troubles. By using a regular maintenance programme (preventative maintenance) to care for a system, you can eliminate common problems and anticipate special ones. Problems can be corrected or averted before a breakdown occurs.

The following are the key problems that commonly need to be addressed in pneumatic maintenance:

- Water-contaminated air
- Poor air filtration
- Incorrect pressure settings
- Incorrect lubricator settings, resulting in sticking valves
- High air temperature
- Loose supply lines
- Faulty seals

## IMPORTANCE OF CLEANLINESS

Cleanliness is of supreme importance when it comes to servicing pneumatic systems. Keep dirt and other contaminants out of the system. Small particles can score valves, cause seizing of components and clog orifices, resulting in expensive repair jobs.

When servicing a pneumatic system, always do the following to ensure cleanliness:

- Keep the compressor and machine's lubricating oil clean
- Keep the system clean
- Keep your work area clean
- Be careful when you change seal or components (take photos)
- Use caution with compressed air
- Ensure all pneumatic components supply lines are secure

## AIR INLET FILTER

Prior to commencing each pumping operation:

- Check that all fittings and connection are serviceable.
- Adequate compressed air is available.
- A general visual inspection of the unit including the suction and discharge valves is recommended.



A small metal gauze in-line filter prevents foreign objects entering the venturi nozzle via the air supply line.

Solidsvac Pumps recommend periodic inspection and cleaning as required, replacement filters and seals are available from your Solidsvac suppliers.



## EXHAUST BOX

If fitted, Solidsvac Pumps also recommend a periodic visual inspection of the exhaust box be carried out.

- With the air supply off and isolated, remove the pump cover.
- Visually check the exhaust opening and if it appears blocked, either flush the box with a hose, alternatively, remove the 4 cap screws in the side cover.
- Ensure that there is no foreign material inside the box, remove and clean the chain and insert back into the box.
- Reinstall the cover and recommence operations.

## AIR FILTER

The Solidsvac SV70-SPDK is fitted with an auto drain filter to reduce foreign media entering via the air supply.

Solidsvac recommends the air filter is inspected regularly and the filter is changed as required.



# SAFETY FIRST

**PRIOR TO COMMENCING ANY WORK ON THE UNIT, THE AIR SUPPLY VALVE MUST BE ISOLATED AND THE CONTROL SYSTEM TESTED DEAD**

## 8. ADJUSTING THE LOAD & DISCHARGE CYCLES

Adjusting the LOAD and DISCHARGE cycles may be required depending on the viscosity of the material being transferred and the distances involved etc. Turning either respective Timer Dial clockwise increases the load or discharge time and turning it anti-clockwise decreases the load or discharge time.

**NOTE: Do NOT turn the knob more than one turn (360°) when adjusting the cycle time.**



Adjust timers to dial marking beside each timer.  
Only adjust timers when required.

Before starting the pump, adjust timers to  
between 4-6 seconds.

**IMPORTANT NOTE: Numbers provided on timers are a guide only and may not be approximate to actual timer figure indicated.**

## PRESSURE RELIEF VALVE

The Pressure Relief Valve can be operated by pulling the ring as indicated below:



## 9. ACCESSORIES

**Suction Wand** – Attaches to the suction hose allowing the operator to stand upright and ambient air to be introduced at the material inlet.

**Strainer** – Available in two sizes and attaches to the suction hose to prevent the ingestion of oversize particles.

**VacHead** – An industrial vacuum head with squeegee brush allows the operator to stand upright, recovering material from hard surfaces i.e. an oil spill from a road surface.

**Note:** It is recommended that the suction timing cycle is set to 15 seconds when using this accessory.

**Delivery Carousel** – Controlled discharge to either a conveyor or multiple points/skips etc.

**Hoses** – A complete range of high quality suction and discharge hoses are available.

**Hoover Head** – Helps focus the vacuum and is ideal for recovering heavier material such as barite, oil sludge, mud or similar from tank bottoms and various hard surfaces.

**Dropbox** – Delivery of material to a skip, conveyor or specific point.

**Tool Kit** – Contains all you need for basic maintenance on your pump.

**Service Kit** – Contains all you need for basic maintenance on your pump.





# **OPERATIONAL RISK ASSESSMENT**

## **OBJECTIVE:**

The objective of the hazard identification and risk review process is to ensure all hazards are identified and accurately assessed for risk. Suitable and effective controls MUST be nominated and implemented to keep workplace safe.

## **CONTEXT:**

The Solidsvac Mobile Solids Pump is designed to be used for the purpose of pumping and transferring heavy slurry/media. The Solidsvac Mobile Solids Pump will be in a stationary position on the floor. The floor conditions need to be safe and level.

## **SCOPE:**

The Scope of the risk assessment as follows:

- 1) Identify operational hazards associated with the use of the Solidsvac Mobile Solids Pump
- 2) Risk Assess each of the identified hazards
- 3) Implement controls to minimise any hazards to an acceptable level

## **INVOLVED PERSONS/STAKEHOLDERS:**

Risk Facilitator

Solidsvac Management/Tradespeople

## **ASSUMPTION:**

### *Supplier*

Competent, comply with standards and drawings.

### *End User (Owner/Hirer/User)*

The end user has:

- Competent (operators are trained, competent, authorised, etc.)
- Procedures (change management, traffic rules, risk assessed, developed, effectively implemented, etc.)
- Equipment fit for purpose (rated, designed compatible, maintained, inspected, monitored, etc.)
- Leadership (communication, directions, monitoring, etc.)
- Environmental conditions are compatible to the operational capabilities of the equipment (natural vs. man-made, etc.)

## **INCLUSIONS:**

Only the aspects directly related to Solidsvac Mobile Solids Pump.

## **EXCLUSIONS:**

Transporting and storing the Solidsvac Mobile Solids Pump (Users operational risk assessment, training, competence);

Assessment of the environmental conditions in the operational area (Users planning and local risk control)

## **REFERENCE MATERIAL:**

QLD Coal Mining Safety & Health Act 1999

QLD Coal Mining Safety & Health Reg 2001

Recognised Standard 02 Control of Risk Management Practices

## RISK MATRIX

### Step 1: Establish the Consequence (1-5)

Consequences		<b>Injury / Occupational Illness or Disease</b> (How to manage Work Health and Safety Risk – Code of Practice, Safety Work Australia 10 August 2011). The company must ensure levels of consequence and likelihood are relevant to the company's Business risk.	<b>Business Loss/Asset Damage</b>	<b>Reputation/Social/Community</b>	<b>Legal and Regulatory/Contract</b>	<b>Environmental Impact</b> (e.g. Hydrocarbon spills)
1	<b>Insignificant</b>	<b>Report only</b>	<\$5k	Complaint/ Single project or stakeholder	Minor non-compliance - internal report only	Negligible pollution
2	<b>Minor</b>	<b>First Aid Treatment Injury/illness</b> Non-prescription medication/treatment that can be administered by first aider.	<\$20k	Local public concern	Minor legal non-compliance - Contractual issue	Minor pollution/ Nuisance
3	<b>Moderate</b>	<b>Medical Treatment Injury/illness</b> Prescription medication/treatment that can only be administered by a registered doctor/nurse. <b>Minor LTI</b> <5 full days work lost	<\$50k	Regional public concern/Multiple stakeholders	Serious breach of law/Investigation by authority/ On the spot fine. Major breach of contract.	Noticeable pollution
4	<b>Serious</b>	<b>Serious Lost Time Injury/illness</b> Loss of 5 or more days work/admission to hospital/ <b>serious injury under WHSA definition</b>	<\$100k	National public concern	Significant penalties/ Termination of contract	Significant environmental event
5	<b>Major</b>	<b>Fatality</b> Single or multiple fatalities	<\$100k	International public concern	Law suits/ Prosecution/ Removal from suppliers list	Major environmental event/Material environmental harm

### Step 2: Establish the Likelihood (A-E)

Description		<b>Frequency Examples</b> (How to manage Work Health and Safety Risk – Code of Practice, Safety Work Australia 10 August 2011).
<b>A</b>	<b>Certain to occur</b>	Expect to occur in most circumstances (>1 event/month)
<b>B</b>	<b>Very likely</b>	Will probably occur in most circumstances (2 to 1 events/year)
<b>C</b>	<b>Possible</b>	Might occur occasionally (1 event/1 to 2 years)
<b>D</b>	<b>Unlikely</b>	Could happen at some time (1 event/2 to 3 years)
<b>E</b>	<b>Rare</b>	May happen only in exceptional circumstances (>3 to 5 years)

## RISK MATRIX

### Step 3 : The Hierarchy of Risk Control Model

Start at the top and only if you can't select controls from one section, move to the next one down.  
You need to use a combination of control measures to achieve the second level of risk control.  
If a particular hazard can't be removed the risk associated with the hazard can never be eliminated.

1	<b>Elimination</b>	Complete removal of the hazard	Most effective
2	<b>Substitution</b>	Replacing the material of process with a less hazardous one	
3	<b>Isolation</b>	Separate the hazard from people	
4	<b>Engineering</b>	Guarding, ventilation, design, re-design etc	
5	<b>Administration</b>	Providing controls such as training and procedures	
6	<b>PPE</b>	Use of PPE when other controls are not practical	Least effective
7	<b>Post</b>	Mitigation after an event (all Fire extinguisher)	

### Using the Matrix to Determine Risk Score

Likelihood	Consequences				
	1	2	3	4	5
<b>A</b> Certain to occur	Low 11	Moderate 16	Moderate 20	High 23	High 25
<b>B</b> Very likely	Low 7	Low 12	Moderate 17	High 21	High 24
<b>C</b> Possible	Low 4	Low 8	Moderate 13	High 18	High 22
<b>D</b> Unlikely	Low 2	Low 5	Moderate 9	Moderate 14	High 19
<b>E</b> Rare	Low 1	Low 3	Low 6	Moderate 10	High 15
ALARP - As low as reasonably practical					
Tolerable	Take action to manage ALARP		Intolerable (without specific senior management approval)		



REFERENCE	ACTIVITY	SUB ACTIVITY	HAZARD	RISK EVENT	EXISTING CONTROLS	CURRENT RISK WITH EXISTING CONTROLS			RISK TREATMENT (Accept, Transfer, Avoid or Further Risk Review)	ADDITIONAL RECOMMENDATIONS	STATUS (Complete, incomplete, in progress)	Date
						CONSEQUENCE	LIKELIHOOD	RISK RATING				
<p align="center"><b>OPERATIONAL RISK ASSESSMENT</b></p> <p align="center"><b>THIS IS A BASIC R.A</b></p> <p align="center"><b>SOLIDSVAC STRONGLY RECOMMEND THAT</b></p> <p align="center"><b>A SITE-SPECIFIC R.A IS CONDUCTED.</b></p>												
10	Transport to work site	Travel position	Inadequate transport method	Resulting in personal injury and damage to the Solidsvac SV70 Mobile Solids Pump during transport	Wheels and handle on the Solidsvac SV70 Mobile Solids Pump Designed well balanced Mine transport rules	L 8	C	L 8	Placement and loading of the Solidsvac SV70 Mobile Fluids Pump to be included in the training and assessment document in the Solidsvac SV70 Mobile Solids Pump	Open		
11	Set up	Environment	Solidsvac SV70 Mobile Solids Pump set up on uneven ground or pump is inadequately secured to rib when on uneven ground resulting in unplanned movement of pump	Resulting in personal injury and/or damage to the Solidsvac SV70 Mobile Solids Pump during operation	Operation manual and training documents set up procedure on level ground or securing pump to the rib using rated restraining devices when operating on uneven ground	L 8	C	ALARA	Training and assessment in the Solidsvac SV70 Mobile Solids pump package			
			Manual handling	Failure of the correct manual handling technique	Manual handling training at induction team lifts where required Most set up and removal tasks conducted from floor level and reasonable height	L 8	C	ALARA	Training and assessment in the Solidsvac SV70 Mobile Solids pump package			
			Nip/crush points and "line of fire" issues from mobile equipment, low roof height issues during set up and removal resulting in crush injuries	Resulting in personal injury	Operation manual and training documents setup, removal procedures Operation manual and training documents identify the need to drain pump before disconnecting. Mine transport rules line of sight before any movements No machine movements without positive communications HI-VIZ clothing	M13	C	ALARA	Training and assessment in the Solidsvac SV70 Mobile Solids pump package			
			High pressure compressed air	Failure of the compressed air system resulting in Personal injury from being exposed to compressed air due to hose failure and/or damage	Rated pressure hoses Mine site induction and training Competencies	M13	C	ALARA				
12	Operation		Work on or around a moving belt	Interaction with conveyor resulting in personal injury	Mine site Induction and Training Competencies	L 8	C	ALARA				
			Discharged material (at 100psi) contacts operators	Resulting in personal injury	Operation manual and training documents the set up procedure incorporates barricading discharge area with caution tape	L 8	C	ALARA				
			Pinch points on Solidsvac SV70 Mobile Solids pump during operation	Resulting in personal injury	Fit for purpose covers fitted to pump during operation, MUST be in place	L 8	C	ALARA				
			Blocked discharge hose resulting in exposure to stored energy while unblocking hose	Resulting in personal injury	Operation manual and training documents unblocking procedure Pressure relief valve at the pump relieves discharge pump pressure	L 8	C	ALARA				
			Blocked suction hose resulting in process delay	Resulting in personal injury and/or process delay	Operation manual and training documents unblocking procedure Isolation training and procedures Low pressure ie. 10psi Strainer or nozzle fitted to suction hose	L 8	C	ALARA				
13	Maintenance		Incorrect maintenance resulting in equipment failure	Resulting in personal injury and/or process delay	Tested to Australian Standards OEM Maintenance scheme	L 8	C	ALARA	Maintenance to be carried out as per OEM Suppliers SV70 Operation/Maintenance Manual			

## RISK REGISTER ACTION PLAN

No	ITEM/ISSUE	AGREED ACTION	WHO	WHEN	COMP DATE	REVIEW/AUDIT DATE
Operation	Storage	Communicate to end user to develop work procedures for storage of Solidsvac SV70 Mobile Fluids Pump	Solidsvac	Delivery		
	Travel position	Communicate to end user to develop work procedures for travelling	Solidsvac	Delivery		
	Use of Solidsvac SV70 Mobile Fluids Pump	Supplier to develop work procedures for operating the Solidsvac SV70 Mobile Solids Pump	Solidsvac	Delivery		
Maintenance	Daily	Supplier to develop daily and/or pre-use visual inspections procedures for using and operating the Solidsvac SV70 Mobile Solids Pump	Solidsvac	Delivery		
	Weekly	Supplier to develop weekly visual, operational, maintenance inspections for using and operating the Solidsvac SV70 Mobile Solids Pump	Solidsvac	Delivery		

# PUMP PREVENTATIVE MAINTENANCE PROGRAM

The following is the work to be performed to a SV70-SPDK Pump during Preventative Maintenance Check.

All items, except annual checks (Tradesman), are to be carried out by a Competent Operator.

- Lock and tag out equipment
- Record equipment data
- Check all mounting and flange bolts are secure and tight
- Check vessel support frame and wheels for soundness
- Visual inspection of pump for any damage
- Check for knife gate seal leaks
- Check condition of flange gaskets
- Check knife gate packing for excessive leakage and adjust and/or replace
- Make sure all timers are operational
- Check operation of Pressure Relief Valve
- Check in-line gauze filter
- Inspect condition of airlines and fittings
- Check operation of swing check valve (if fitted)
- Check condition of venturi nozzle
- Test the operation of the SV70-SPDK pump prior to returning to service
- Make note on the field report of any findings that may require additional work

# PUMP MAINTENANCE CHECKLIST

DESCRIPTION	COMMENT	MAINTENANCE FREQUENCY			
		DAILY	WEEKLY	MONTHLY	ANNUALLY
Pump use and timing	Check operation of pump prior to use.	X			
Overall visual inspection	Complete overall visual inspection to be sure all equipment is operating and safety systems are in place.	X			
Check knife gate seals	Assure that all seals are in good condition and not worn, split or damaged.		X		
Check knife gate packing	Check packing for wear and leakage and repack as necessary.		X		
Check airlines and fittings	Inspect airlines for any deterioration, check fittings for cracks and leaking.		X		
Check bolts	Check and secure all flange bolts.		X		
Check in-line gauze filter	Check in-line filter for cleanliness and obstructions. Clean as necessary.		X		
Check venturi nozzle and PRV	Check the condition of the venturi nozzle. Check operation of the PRV.			X	
Pressure Vessel Inspection	Inspect the vessel for wear, cracks and/or damage.				X
Full Service and PRV	Conduct a full service on the pump and replace the PRV.				X

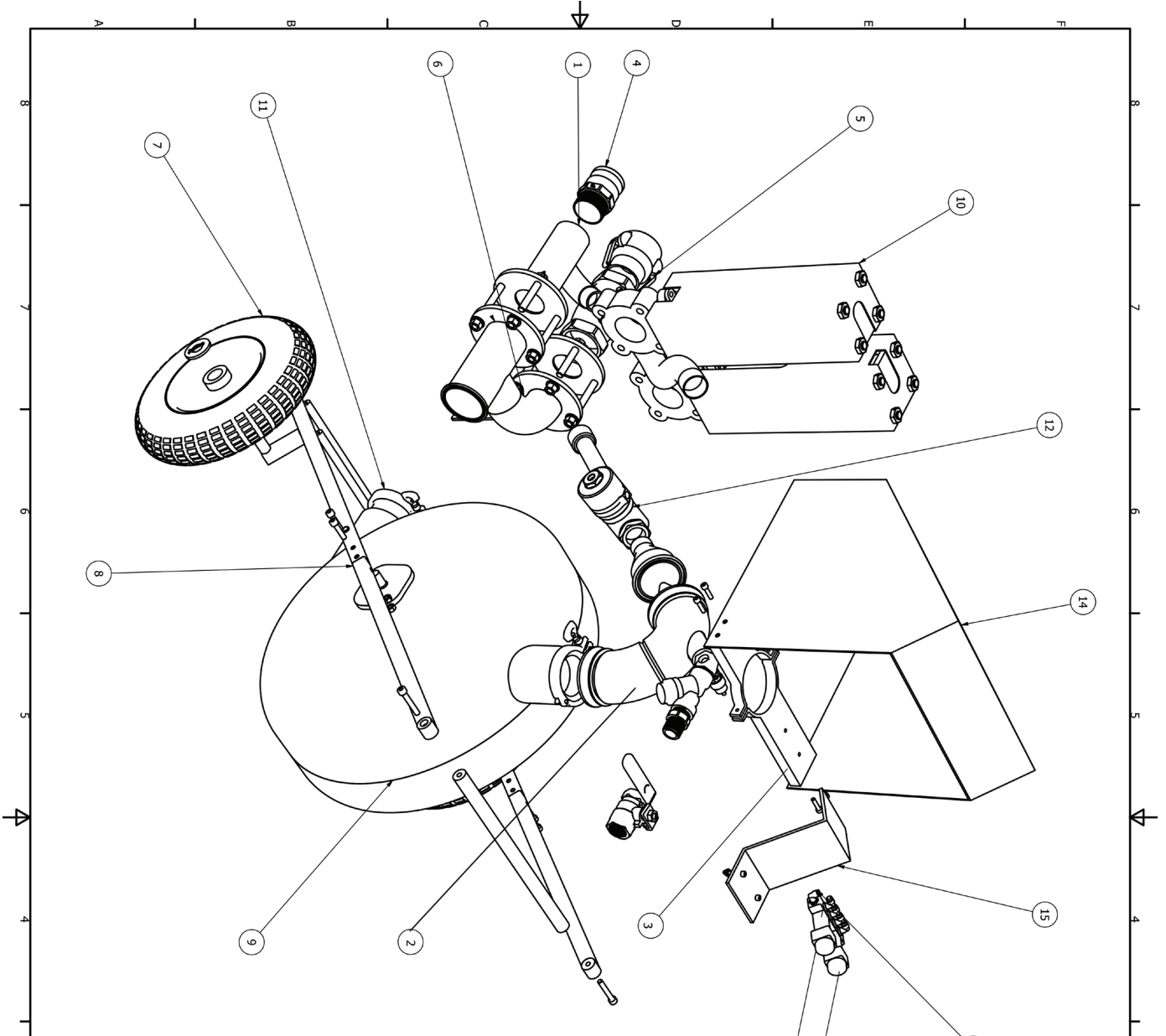

ITEM	PART NUMBER	DESCRIPTION
1	SV70-18	3" DISCHARGE FLANGE
2	SV930	100CFM JETPACK
3	SV70-4	COVER TIMER BLOCK COLLAR
4	SV926-F	3" CAMLOCK F TYPE
5	SV926-B	3" CAMLOCK B TYPE
6	SV70-20	3" SUCTION DISCHARGE MANIFOLD
7	SV924	WHEEL - NON PUNCTURE
8	SV70-2	FRAME ASSEMBLY
9	SV70-3	VESSEL
10	SV70-34	3" KNIFEGATE COVER
11	SV912	3" TRICOVER CLAMP
12	SV930-4	50/100/180 DIFFUSER VALVE ASSEMBLY
13	SV70-SPDK-13	HOSE
14	SV70-1	COVER
15	SV440	TIMER SOLENOID MOUNT BRACKET
16	SV440	TIMER LOAD
17	SV440	TIMER DISCHARGE
18	SV928	TIMER BLOCK
19		
20		
21		

<p><b>SOLIDSVAC</b></p> <p>SOLIDS PUMPING SYSTEMS</p>	<p>DRAWN: 10/18/2019</p> <p>RELEZ: J.KROHN</p> <p>CHECKED: J.KROHN</p> <p>QA: 12/04/21</p> <p>MFG: M.KROHN</p> <p>APPROVED: M.KROHN</p>	<p>TITLE: SV70-SPDK EXPLODED VIEW</p> <p>SIZE: A2</p> <p>DWG NO: SV70-SPDK-01</p> <p>SCALE: 1/5</p> <p>REV: 1.1</p>
---	---	---

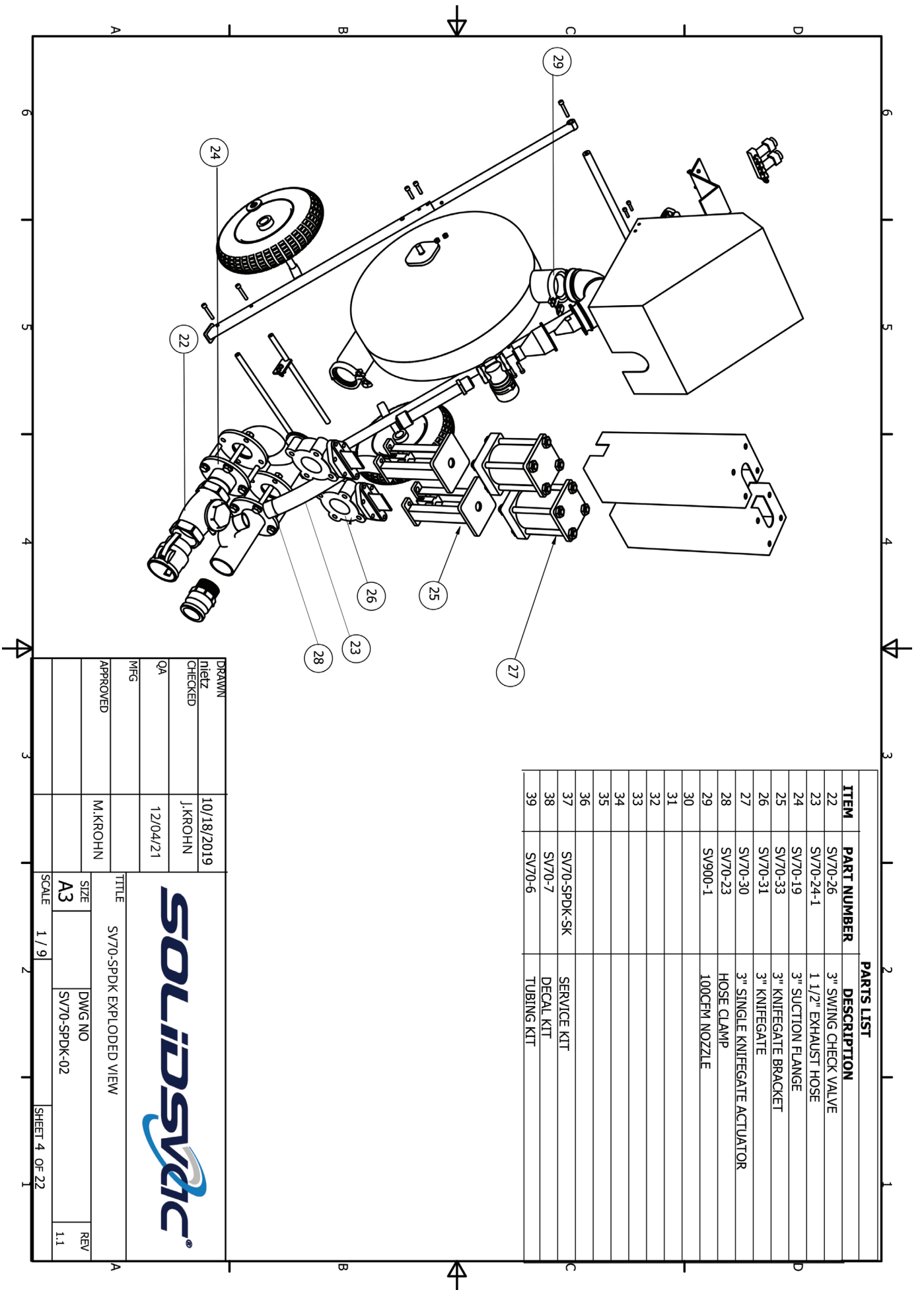

ITEM	PART NUMBER	DESCRIPTION
22	SV70-26	3" SWING CHECK VALVE
23	SV70-24-1	1 1/2" EXHAUST HOSE
24	SV70-19	3" SUCTION FLANGE
25	SV70-33	3" KNIFE GATE BRACKET
26	SV70-31	3" KNIFE GATE
27	SV70-30	3" SINGLE KNIFE GATE ACTUATOR
28	SV70-23	HOSE CLAMP
29	SV900-1	100CEM NOZZLE
30		
31		
32		
33		
34		
35		
36		
37	SV70-SPDK-SK	SERVICE KIT
38	SV70-7	DECAL KIT
39	SV70-6	TUBING KIT

DRAWN	10/18/2019
nietz	
CHECKED	J.KROHN
QA	12/04/21
MFG	
APPROVED	M.KROHN

**SOLIDSVAC**

TITLE SV70-SPDK EXPLODED VIEW

SIZE A3	DWG NO SV70-SPDK-02	REV 1.1
SCALE 1/9	SHEET 4 OF 22	

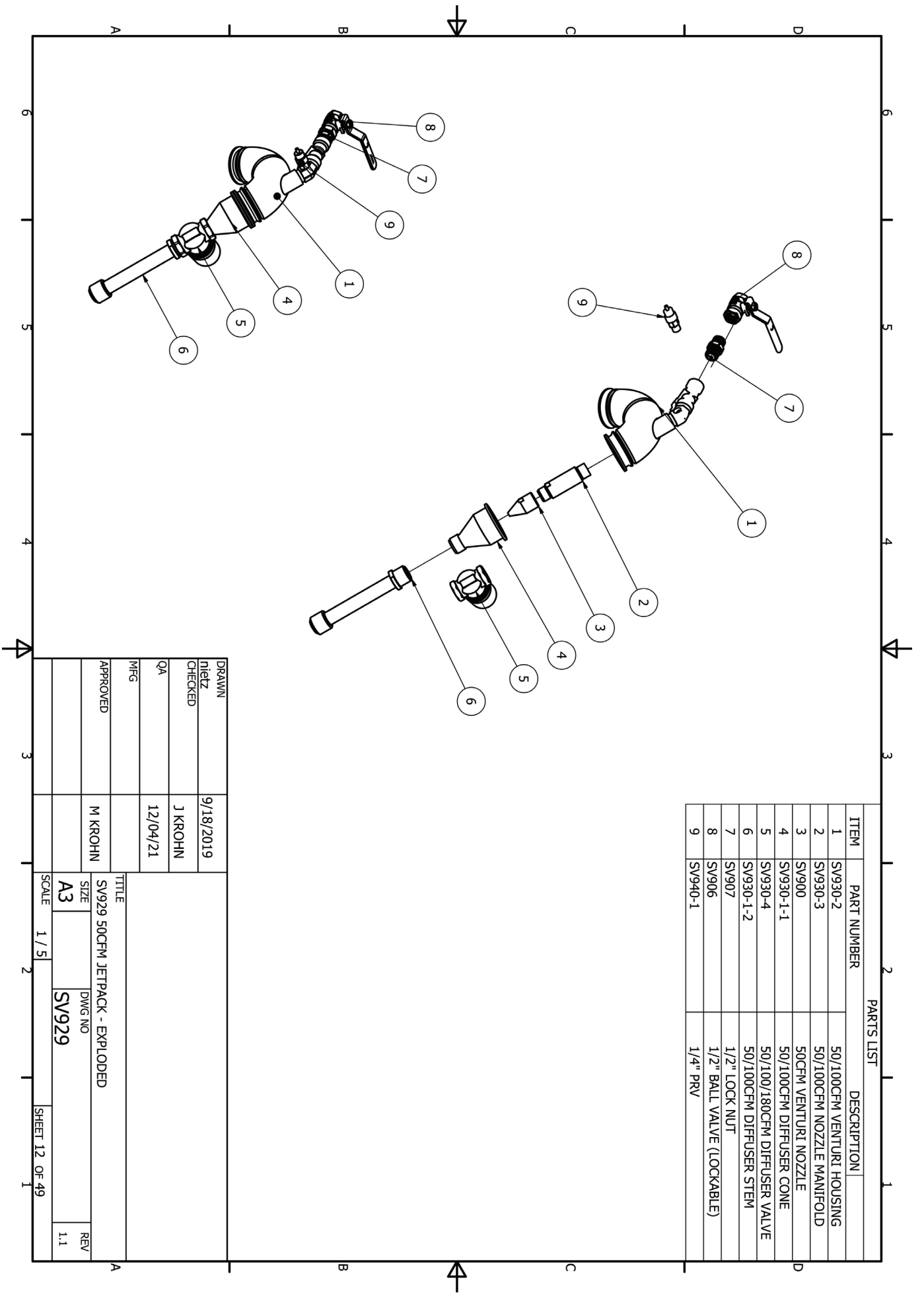

ITEM	PART NUMBER	DESCRIPTION
1	SV930-2	50/100CFM VENTURI HOUSING
2	SV930-3	50/100CFM NOZZLE MANIFOLD
3	SV900	50CFM VENTURI NOZZLE
4	SV930-1-1	50/100CFM DIFFUSER CONE
5	SV930-4	50/100/180CFM DIFFUSER VALVE
6	SV930-1-2	50/100CFM DIFFUSER STEM
7	SV907	1/2" LOCK NUT
8	SV906	1/2" BALL VALVE (LOCKABLE)
9	SV940-1	1/4" PRV

PARTS LIST	
ITEM	DESCRIPTION
1	50/100CFM VENTURI HOUSING
2	50/100CFM NOZZLE MANIFOLD
3	50CFM VENTURI NOZZLE
4	50/100CFM DIFFUSER CONE
5	50/100/180CFM DIFFUSER VALVE
6	50/100CFM DIFFUSER STEM
7	1/2" LOCK NUT
8	1/2" BALL VALVE (LOCKABLE)
9	1/4" PRV

DRAWN	9/18/2019	TITLE	SV929 50CFM JETPACK - EXPLODED
CHECKED	J KROHN	SIZE	A3
QA	12/04/21	DWG NO	SV929
MFG		SCALE	1 / 5
APPROVED	M KROHN	SHEET	12 OF 49
		REV	1.1



# ***JOB SAFETY ANALYSIS***

Note: It is recommended that a site-specific JSA is conducted prior to operation of the unit.



# JOB SAFETY ANALYSIS

## SOLIDSVAC SV70-SPDK SLURRY PUMP

Date Of Audit – June 2016.

Equipment/Task: Set-up and operate Solidsvac Solids/Slurry Pump.

**Note: Site Safety requirements MUST be adhered to at all times. Personal Protective Equipment including approved safety eyewear and hearing protection are to be worn at all times whilst operating this equipment.**

STEP #	JOB STEPS	HAZARDS/WHAT CAN GO WRONG	CONTROLS & RISK REDUCTION
1	Siting the pump.	The pump may be unstable.	Site the pump on a reasonably flat, level & stable surface, or on a suitable straddle frame.
2	Connecting discharge hose range to pump.	(a) Use of inappropriate non pressure rated discharge hose, hose or couplers may cause discharge hose range failure.	Ensure minimum 2" discharge range is used rated to 10Bar. Hose may be rubber or poly. The pump utilises the camlock coupling system. Use Solidsvac supplied FRAS rubber Stainless Steel camlock ended pressure rated hose ass'y to enable safe connection.
		(b) Sharp bends, tee pieces and valves in a discharge line can cause blockages.	Ensure discharge hose range has no sharp bends or tee pieces and is free of restrictions such as reductions in hose diameter or gate valves etc.
		(c) Discharge hose range may move particularly at discharge exit point.	Ensure discharge hose range is secured at appropriate points along its length and particularly at discharge exit point.
3	Connecting the suction hose to the pump.	Sharp bends, tee pieces and valves in a suction hose can cause blockages.	Wear eye and hearing protection. Hold hose firmly. Ensure suction hose range has no sharp bends or tee pieces and is free of restrictions. Ensure suction hose couplings are correctly engaged and have safety clips fitted.
4	Connecting the air supply hose to the pump. Air hose should be blown clean before connection.	(a) Compressed air can be dangerous and may cause injury. Blowing air supply hose clean can cause eye, hearing or physical injury if not carried out in a controlled manner.	Ensure air hose is turned off completely and that the pump air inlet ball valve is closed before connection.
		(b) Air supply hose can 'fly off' if not properly connected.	Ensure air line couplings are correctly engaged and have safety clips fitted.

# JOB SAFETY ANALYSIS

## SOLIDSVAC SV70-SPDK SLURRY PUMP

Date Of Audit – June 2016.

Equipment/Task: Set-up and operate Solidsvac Solids/Slurry Pump.

**Note: Site Safety requirements MUST be adhered to at all times. Personal Protective Equipment including approved safety eyewear and hearing protection are to be worn at all times whilst operating this equipment.**

STEP #	JOB STEPS	HAZARDS/WHAT CAN GO WRONG	CONTROLS & RISK REDUCTION
5	Pump Operation – Unblocking Suction Hose or Suction Wand.	Reverse flushing of suction hose or suction wand nozzle with high pressure water hose can result in eye injury.	If disconnecting suction hose or suction wand – stop the pump. Wear approved eye protection.
6	Pump Operation – Unblocking Discharge Hose Range Blockages.	Pressure in discharge range has potential to cause eye and physical injury.	STOP THE PUMP. DO NOT DISCONNECT ANY DISCHARGE HOSE RANGE COMPONENT WHILST PUMP IS OPERATING. Depressurise the discharge hose range by operating a manual pressure relief valve on the pump or within the hose range (if fitted) OR, using EXTREME CAUTION, loosen hose couplings upstream of the estimated blockage point (i.e. between pump and blockage) to safely vent residual pressure before attempting to fully open hose joints to clear the blockage.
7	Pump Operation – Discharge Hose Range Exit Point.	Injury can be caused by high velocity material ejected from discharge point.	Do not stand in front of the discharge hose range exit point. Minimise risk by directing this point away from traffic zones. Use Solidsvac supplied Dead Head/Drop Box to reduce velocity & control material at discharge point.
8	Disconnecting Pump from Air Supply.	Injury may result from uncontrolled whipping of pressurised air hose.	Before disconnecting air hose isolate it upstream & open the Pump Air Supply Ball Valve to release residual pressure from the air line.

Model Number

Serial Number

Date of Manufacture

Inspected by



U1/ 5-7 Boeing Place - Caboolture - QLD 4510 - Australia

+61 456 000 665 / info@solidsvac.com

[www.solidsvac.com](http://www.solidsvac.com)