

Model 12-140E

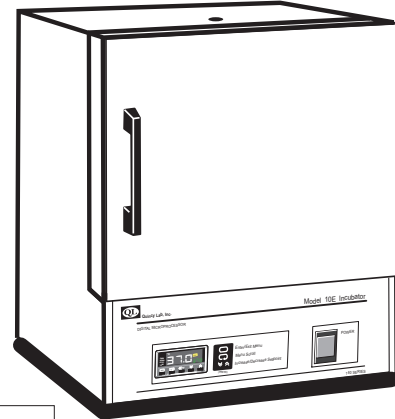

Model 10-180E



SPECIFICATIONS	MODEL 10-140E	MODEL 12-140E	MODEL 10-180E	MODEL 12-180E
Interior Dimensions				
INCHES W x H x D	12x10x10	18x16x12	12x10x10	18x16x12
(CM) W x H x D	31x25x25	46x41x30	31x25x25	46x41x30
Exterior Dimensions				
INCHES W x H x D	13x15x11	19x21x13	13x15x11	19x21x11
(CM) W x H x D	33x38x28	48x53x33	33x38x28	48x53x33
Weight (lbs)	19 lbs	33 lbs	19 lbs	33 lbs
Cubic Foot Capacity	.7 ft ³	2.0 ft ³	.7 ft ³	2.0 ft ³
Standard Electrical				
VOLTS / WATTS	115 / 120*	115 / 235*	115 / 270*	115 / 385*

Temperature Range	Ambient + 2°C to 62°C	Ambient + 3°C to 94°C
--------------------------	-----------------------	-----------------------

Common Unit Specifications

Operating Environment:	Indoor use, altitude to 6,500 ft. (2,000m) Installation Category II, Pollution Degree 2, ambient temperature 10°C/50°F to 35°C/95°F, 80% RH maximum.
Storage Temperature:	-10°C/14°F to 70°C/158°F, 70% RH maximum.
Approvals:	Underwriter's Laboratory Listed, Laboratory Equipment, C/UL United States/Canadian. E212550 (115VAC models only)
Compliance:	UL Standard 61010-1, IEC 61010-1, 2nd Edition.

Common Unit Construction

Exterior: Powder-Coated Steel	Interior: Aluminum
Insulation: Fiberglass	Door: 140E: Acrylic, 180E: Steel Insulated
Thermo-control: PID Microprocessor	Heater: Resistive-Tubular Incoloy

Safety Precautions Read Operating Instructions Thoroughly Prior to Operation

Read Operating Instructions thoroughly prior to operation and observe the following safety precautions:

- Use only a grounded outlet that is rated for your model's electrical requirement.
- Do not modify the oven or factory control settings to operate the oven above the stated maximum operating temperature.
- Exterior surfaces on the 180E models may become hot to the touch when operating at higher set temperatures.
- Conduct periodic maintenance as required.

WARNING: Do not place volatile or combustible materials inside the incubators.

CAUTION: This unit is not intended for use with any flammable liquids or vapors, or with chemicals that produce toxic gases.

Set-Up and Installation

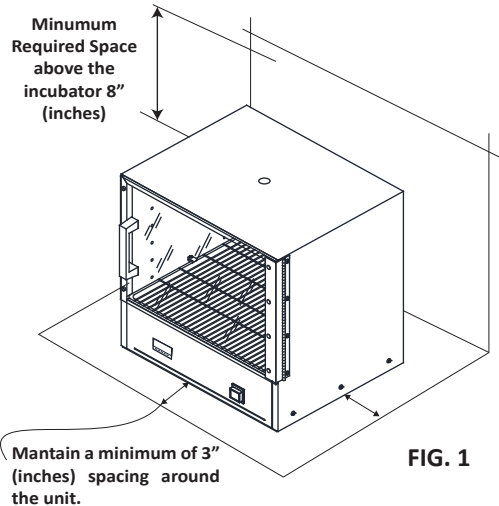

FIG. 1

INCUBATOR SET-UP

- Place the Incubator on a flat surface. Maintain a minimum of 3" (7.6 cm) of airspace around the unit and a minimum of 8" (20.32 cm) above the unit (FIG.1).
- Install the desired shelves in the unit (see Shelf Installation).
- Plug the unit into a grounded outlet that is rated for your model's electrical requirement.

IMPORTANT:

Do NOT modify the provided plug. Do NOT use an extension cord. Use an individual branch circuit for your incubator. For information on your unit's electrical specifications and rated voltage, refer to label on the back of the unit.

INCUBATOR SHELF INSTALLATION

Your incubator allows shelves to be adjusted at different heights in the unit and are easy to install and adjust using the wire shelf brackets. To install and/or adjust shelves follow the steps below:

- Align bracket ends with holes located inside the ovens walls (FIG. 2)
- Insert shelf bracket ends into the hole and press down on the bracket as shown in (FIG. 3). Repeat process on the opposite side of the wall.
- Place shelf on top the the brackets.

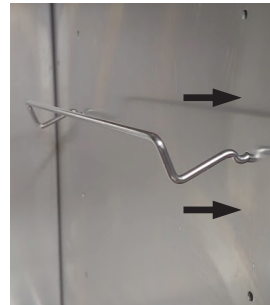

FIG. 2



FIG. 3

General Operation

The unit is ready for your immediate use. All control parameters, calibration, and tuning has been done at the factory, **no adjustments are necessary**.

Push the illuminated power button. All LEDs on the temperature control will light up and display the current chamber temperature (white LEDs), the set temperature (green LEDs), and the active output yellow indicator light (OUT).

The set temperature is constantly displayed in the lower right-hand corner of the display. To change the set temperature, simply press the up arrow key or the down arrow key until the desired set temperature is reached. (FIG 4)

The temperature control is set at the factory to read in 1/10 degree F, or Fahrenheit units. To make a change see: **Menu Level Functions (page 3)**.

Once the unit reaches the desired set-point, allow the incubator to cycle for 20 minutes for the temperature to become fully stable.

IMPORTANT:

Upon each initial powering-up, the control may typically overshoot the set temperature by 1 or 2 degrees, especially if the temperature set point is close to the operating ambient temperature. After equilibrium is achieved the control will hold set temperature within the model specified tolerance.

NOTE: FLASHING **YELLOW** LIGHT **OUT** INDICATES NORMAL OPERATION.

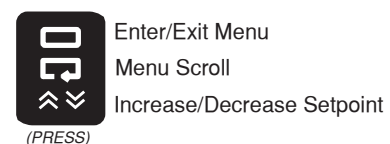
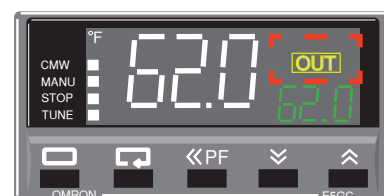

Enter/Exit Menu

Menu Scroll

Increase/Decrease Setpoint

(PRESS)

FIG. 4

Menu Level Functions Guide

To navigate the controller's menu, please refer to the easy-to-use Menu Guide below: Menu setting changes can be done quickly with our 5-button digital microprocessor. Your incubator's controller allows you to easily do the following:

- Set the operating set-point temperature
- Select between degrees Fahrenheit or Centigrade
- Calibrate your unit to your independent temperature sensing device.
- Auto-tune your Incubator for maximum efficiency
- Lock the set-temperature

MENU GUIDE



Temperature Set-point

This is the target temperature value which the unit will operate under normal conditions. The value is located on the lower right corner (green LEDs) and can be adjusted to your model's specified temperature range.

To change the SP (set-point)

Press the or arrow key to adjust

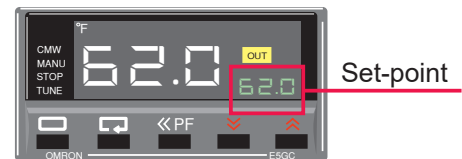

Temperature Units

This parameter allows the controller to work and display the temperature on the specified unit. The value on the parameter can be adjusted to run in °F or °C.

To change the UNIT from °F to °C

Press and hold for (3) seconds

Press or to toggle between temperature units.

The factory default operational is set to run in °F.

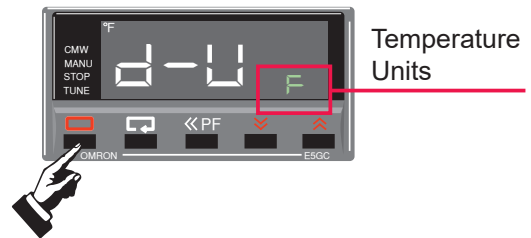

Temperature Offset

Your incubator's temperature offset value has been adjusted at the factory so that the temperature displayed on the controller (white LEDs) reads the same as your unit's interior chamber temperature when measured against a NIST (National Institute of Standard and Technology) traceable temperature box.

If an offset needs to be performed in the field to adjust the temperature displayed on the controller to match your independent temperature probe, follow the sequence shown below:

To calibrate control to independent probe/sensor

- Press once and press once to see .
- Adjust using arrow key.
- Press once to return to temperature display.

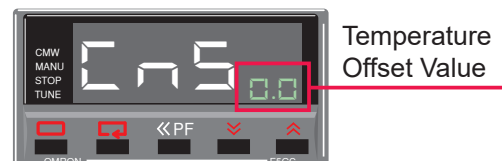

Auto-tune

The control's P.I.D values have been derived from a performed tuning at the factory using the AT-1 option which allows for optimal performance and faster response time. You may, however, choose to tune your incubator to your specific application and/or most used set-point temperature by selecting and performing one of the tuning options shown below.

At-1 (for 40% Auto-tune) - The 40% Auto-tune (At-1), will stabilize the oven temperature quicker and with less 'overshoot', but will be somewhat less precise.

At-2 (for 100% Auto-tune) - The 100% Auto-tune (At-2) will take longer to stabilize oven temperature but will be more precise. This option takes longer to complete the Auto-tune process.

To auto-tune your incubator

Set the set-point to which the incubator will Auto-tune.

Press  once to see **At**

Press  or  to toggle between **At-1** or **At-2**



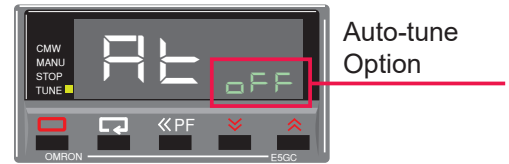

Select tune option, press  once to begin auto-tuning.



NOTE: Yellow light next to the word TUNE indicates auto-tune is in progress.

How to lock controller's Set-Point

The controller can be locked so that no changes can be made to the incubator's set-point. Follow the steps below to lock your controller.

- Press the and HOLD   together for (3) seconds.
- Change **OFF** to (3) using  arrow key.
- Press and HOLD   together for (3) seconds to return to temperature display.

To unlock controller simply change the **OFF** value back to zero (0).

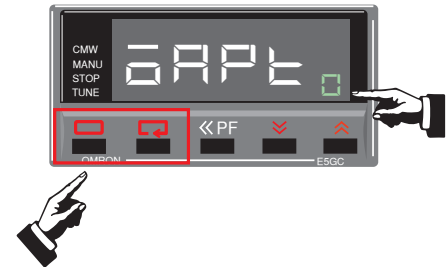

 Setting the **OFF** setting to (3) will lock all parameters on the controller.

Factory default **OFF** is set to (0).

Controller Alarm

ELECTRONIC FAIL SAFETY ALARM

If the incubator exceeds its maximum allowable internal temperature, the safety alarm in the controller ( represents alarm condition) will cut power to the heating elements until the warmer is manually reset. **It is important to allow the incubator's temperature to drop below its maximum operating temperature before performing a reset to the unit.**

To reset unit, power **OFF** and **ON** to clear alarm status. If problem remains, please contact technical support for assistance.



Control Self Diagnostics

Control prompts will only display when a fault or alarm condition exists.

ALARM Codes "S.ERR" & "- - - -"

S.ERR or **- - - -**

Indicates Input Error

Check to make sure Thermocouple wiring is connected securely

ALARM Code "E333"

E333

Indicates Internal Circuit Error

Turn Controller OFF and On. If problem remains, replace Controller

ALARM Code "E111"

E111

Indicates Internal Memory Error

Turn Controller OFF and On. If problem remains, replace Controller

Chamber Loading

Understanding the unit's light pressure thermal convection and "load-effect" are necessary to optimize unit performance. Article or media processing times and/or uniformity are largely dependent on load density and positioning.

Important guidelines to chamber loading and processing:

- Load the incubator so that air circulation within the chamber is not impaired.
- Leave a space between articles on the shelf.
- Stagger articles from those on lower shelves in a "V" formation. (FIG. 6)
- Avoid the use of large solid trays or foil on lower shelves, this can drastically limit heat to shelves and articles placed above.
- Avoid extremely large (in quantity or size), or high-density loads (FIG. 7). This will show by non-uniform processing and long or impossible "heat-through" times. To help determine a large load's suitability, use the set-point recovery time (the time it takes for the temperature to recover to the original set temperature once load is placed), as a guide.
- To reduce recovery time, reduce load proportionally. Also, large loads such as a beaker containing 2 liters of a solution may require an elevated set temperature for the solution to reach and maintain a lower target temperature. When possible, measure large loads or solution temperatures directly with an ancillary thermometer or probe. **Probes can be inserted at the top port.**
- Process the smallest possible load the application or workload will permit. For best processing of small multiples or a single item, adjust one shelf so that the article(s) is centered in the incubator.
- Avoid placing articles or media against or within an inch of the walls especially on the lower shelf. Heated air from the lower heat-shield, is designed to travel up the sidewalls and can have a slightly elevated temperature from setpoint and the rest of the chamber.

IMPORTANT:

It is important to note that large trays placed on lower shelves prevent enough heat to rise within the chamber. (FIG. 8)

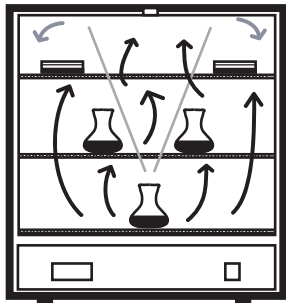

FIG. 6

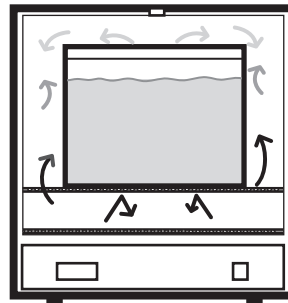

FIG. 7

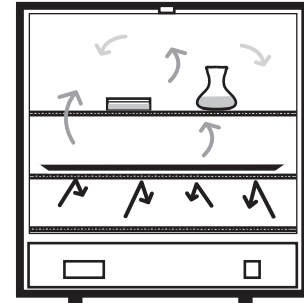

FIG. 8

Important Operational Notes:

The incubator's chamber temperature stability can be affected by changes in ambient (room) temperature and/or equipment running in close proximity (creating microclimates) or cycling on the same electrical circuit. Take time to see how unit location or changes in room temperature from seasonal heating or air conditioning may influence the incubator's set temperature. **For best chamber temperature stability, keep the ambient temperature stable.**

IMPORTANT

- **The unit's minimum operating temperature is largely determined by ambient (room) temperature.** The unit can operate 2°C above room temperature but temperature stability will be degraded.
- The unit's stability improves appreciably for settings that exceed ambient by 4°C or better. Also, the lower the ambient temperature the lower the maximum adjustable operating temperature.
- Adjusting the operational temperature range of the unit for *non-typical ambient conditions* can be done by performing an auto-tune to the unit. (see Auto-tune on controllers function)

Maintenance

To clean interior and exterior surfaces, use a damp cloth with or without an all-purpose cleaner. Avoid commercially available oven cleaners. The acrylic door should only be cleaned using a lint-free cloth, with or without water. Paper towels can mar the surface of the acrylic door. Use of any commercial cleansers on the acrylic door will cause crazing and cracking of the surface of the acrylic over time. **Periodically, verify the temperature accuracy “calibration” of the controller’s temperature display (with the unit empty of contents), against a known accurate or calibrated temperature device (See Temperature Offset on pg. 3 of this manual or Scan the QR-code and see the Digital Incubator Calibration section at the bottom of the page for additional information).**

- If a liquid is spilled inside the unit, disconnect it from the power supply and have it checked by a competent person.
- It is the user’s responsibility to carry out the appropriate decontamination if hazardous material is spilled on or inside the unit.
- It is the user’s responsibility not to use decontamination or cleaning agents that could cause a hazard as a result of a reaction with parts of the equipment or with the material contained in it.



Troubleshooting

PROBLEM	POSSIBLE CAUSE	WHAT TO DO BEFORE CALLING TECH. SUPPORT
Unit not turning ON when switch is in the ON position	1. <i>Tripped GFCI power outlet</i>	1. Check if the unit tripped a GFCI outlet or fuse. Try a different power outlet connection before moving to number 2 on this list.
	2. <i>Damaged or missing fuse</i>	2. Check (red) fuse holder in the back of the unit for missing fuse or broken fuse. Replace as needed.
	3. <i>Disconnected / loose wires.</i>	3. Check all wire connections in the electrical area (bottom) and make sure there are no loose or disconnected wires in the unit.
Incubator not heating or over heating.	1. <i>Set temperature not set correctly or set too low.</i>	1. Make sure the setpoint temperature is set correctly on the lower right corner and is above the stated 2°C (140 series) or 3°C (180 series) above room temperature.
	2. <i>The unit overheated and alarmed</i>	2. Turn unit OFF and ON to clear (SUB/OUT) Alarm, if the problem persists contact Quincy Lab. for further assistance.
	3. <i>Incorrect OFFSET ($\square \square \square$) value</i>	3. Verify that the Temperature Offset (pg.3) is between -10°F to 10°F. Any value higher than this may affect the heating process. Bring value down to zero, and perform a temperature calibration. Scan QR-code above for additional information.

Common Replacement Components

Digital P.I.D Controller PART # 101-1230 S.S Relay PART # 401-1235	SPACE LEFT INTENTIONALLY BLANK
-------------------------------------------------------------------------------------------	-----------------------------------

For a complete list of replacement components, part and additional equipment, visit us on the web at www.quincylab.com

Common Additional Equipment

10 Series Wire Shelf PART # 101-1000	10 Series Shelf Support PART # 101-1001
12 Series Wire Shelf PART # 101-3000	12 Series Shelf Support PART # 101-3001

Technical Support

If you have any questions or need technical assistance, contact Quincy Lab technical support for further assistance, or visit us on the web at www.quincylab.com

Email: information@quincylab.com
Voice: 800-482-4328
Fax: 773-622-2282

Quincy Lab, Inc.
109 Shore Dr.,
Burr Ridge, Illinois 60527

Limited Warranty



Quincy Lab, Inc. warrants to the original purchaser that this product will be free from defects in material and workmanship under normal use throughout the warranty period. The standard warranty period for this instrument is twenty four (24) months from date of shipment. The instrument warranty is supplemented with a three year warranty on the heating element. Please refer to your invoice or shipping documents to determine the active warranty period. This warranty covers parts & labor (labor at factory only) and shipping cost for replacement parts.