

# Designed and built by Top Drive Experts and Engineers



MECHALTA Group.  
 Bay 1, 6125 11 Street SE  
 Calgary, AB T2H-2L6, Canada  
[www.mechalta.com](http://www.mechalta.com), [milanr@mechalta.com](mailto:milanr@mechalta.com)



Field Proven for last 10 years

### Advantages

- \* Designed by Engineers who designed Top Drives
- \* More than 200 units in service
- \* Compact Design allowing sufficient room for links to pass
- \* Open and closes while still in rotation (no need to stop)
- \* No loading on the valve body
- \* Accurate ball valve alignment
- \* Extending Valve Life
- \* LOWERING OWNERSHIP COST
- \* Easy field installation
- \* Easily replaceable wear parts
- \* Compact design
- \* Manual operation provision
- \* Simple design with few moving parts

MECHALTA Group is a uniquely independent engineering company formed in **2001** to focus specifically on the proper Oil and Gas Exploration and Production Equipment engineering to clients in all sectors of the upstream and downstream oil and gas industry,

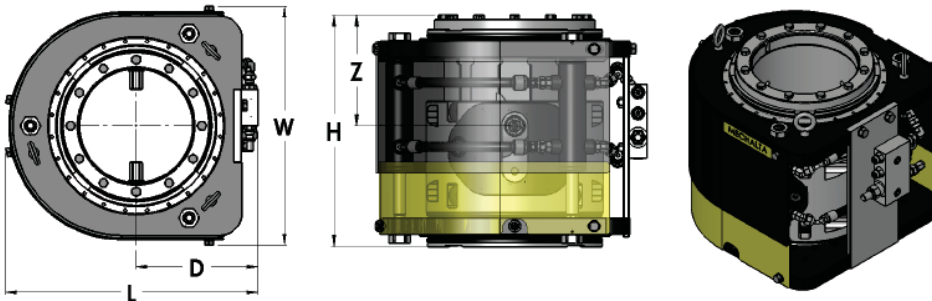

Sizes						
Valve OD	L	W	H	D	Z	Weight
(in)	(in)	(in)	(in)	(in)	(in)	(lb)
6.94	16.50	15.50	14.50	7.88	6.71	225.00
7.75	17.38	16.25	14.50	8.38	6.96	250.00
8.45	18.38	17.25	14.50	8.38	7.00	275.00
8.88	18.38	17.25	14.50	8.38	7.00	295.00
11.00	23.56	21.94	15.66	11.34	8.03	493.00

Max Hydraulic Operating Pressure = 3000 psi  
 Torques Output to Open Valve @ 3000 psi = 1150 lb-ft  
 Torques Output to Close Valve @ 750 psi = 750 lb-ft

**Engineered, Designed,  
 Machined and Assembled  
 in  
 Canada**

