

# AUTOMATED COIN RECYCLER

## SMART COIN SYSTEM

Bulk coin feeder, hopper and recycler

Designed with the  
Operator in mind.



### FEATURES

- Combined bulk coin validator, mixed coin hopper and recycler
- Market leading coin hopper capacity, payout speed, fully audited and efficient refills
- Validates, discriminates and stores mixed coins
- Minimise distance between coin entry and exit points
- Easy maintenance, free firmware updates and data logging
- Closed loop system
- High security - multi frequency sensing technology

### NEED MORE?

Check out our **Twin Smart Coin System** for 100% greater Coin Capacity and 140% greater Payout Speed.



Eliminates coin starvation & the need for multiple hoppers



Reduces operator collection costs



Improve operator cashflow with mixed denomination payouts - keep machines running



Allows for space saving new machine design



Future proof: easy updates via USB, SD card, PC; online update via Host machine



Full audit traceability - no shrinkage

**Technical Specification**

**Smart Coin System**



**Power**

Requirements: 24V  
Standby: 400mA  
Running: 3A  
Peak: 6.5A

**Protocols**

SSP (others on request)

**Interfaces**

USB option / Open collector

**Weight**

Empty: 4kg  
Full: 18kg

**Coin Dimensions**

Diameter: 16 - 28.5 mm  
Thickness: 1.65 - 3.2 mm

**Coin Capacity**

1400 (€1) or 1800 (quarters)  
or 1200 (€1)

**Mixed Coin Capacity**

350 (€2) + 700 (€1) + 200 (50c)

**Payout Speed**

Up to 10 coins per second

**MCBF**

100,000

**Certifications**

UL, CE, ADA Compliant

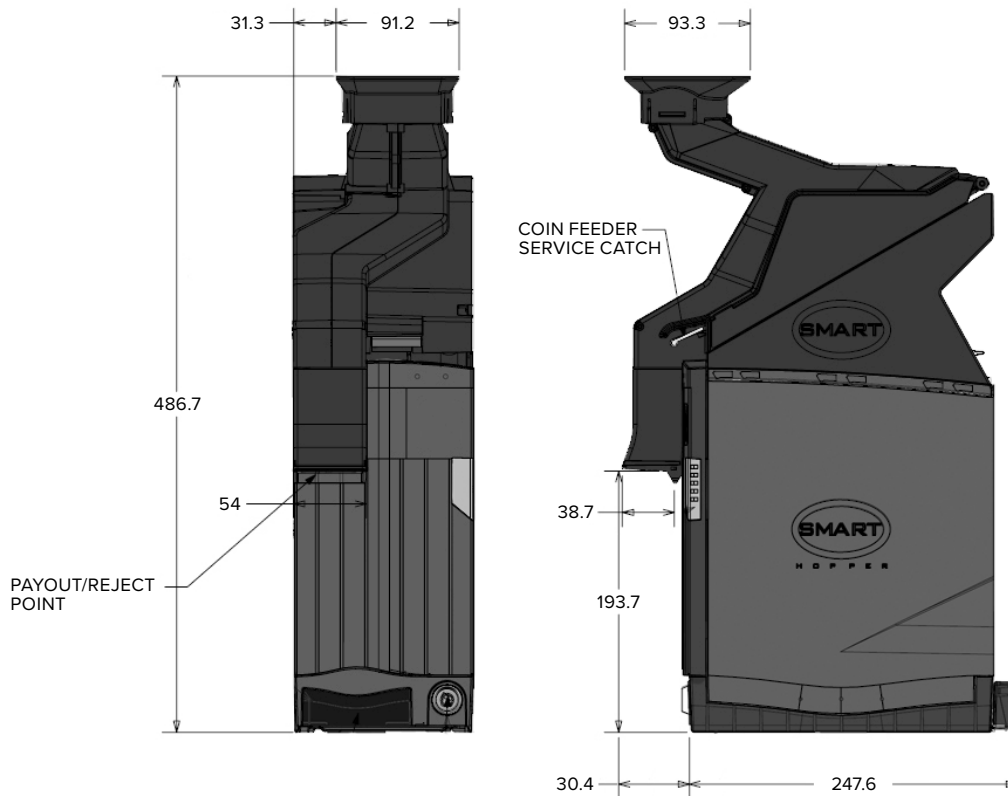

Weight: 4kg (empty), 18kg (full)  
Units of measure: mm