

The ESM series is a submersible series pump with a semi-vortex impeller to help minimize clogging and improved durability. It has a built-in shaft mounted agitator to prevent ‘air lock’ and reduce clogging.

## SPECIFICATION

- Power supply: single phase 120V ± 10%, 60Hz  
Three phase 460V ± 10%, 60Hz
- Insulation class: F
- Protection class: IP68
- Cable length: 26ft
- water temperature: up to 104°F
- Max water depth: 32ft

## APPLICATION

- Civil engineering
- Construction sites
- Basements or other utility pits
- Rainwater
- General pumping purposes
- Pumping fluid: sludge, liquid-containing mud and bentonite

## SPECIAL FEATURES ON REQUEST

- Other voltages
- Optional longer cables

Note: ES: three phase; ESM: single phase; ESM...F: single phase with float switch

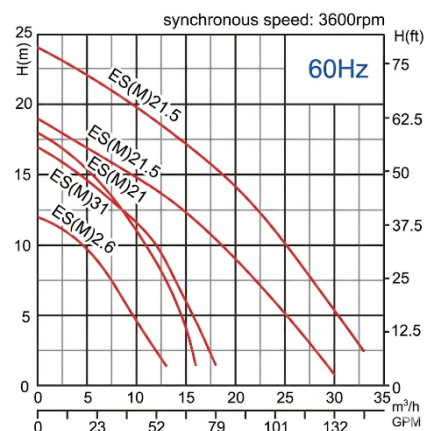

Model	Outlet		Motor Power		Rated current (A)		Rate capacity		Rated head	Rated head	max capacity		max head	Impeller passage
	mm	inch	kW	HP	1	3	m³/h	GPM	m	ft	m³/h	GPM	m	mm
ES(M)2.6(F)	50	2	0.4	0.55	5.5	1.4	7	31	8	72	13	55	12	6
ES(M)21(F)	50	2	0.75	1	9.2	2.4	10	44	11	36	15	66	18	6
ES(M)31(F)	80	3	0.75	1	9.2	2.4	12	53	10	33	18	79	17	6
ES(M)21.5(F)	50	2	1.5	1.5	14.7	3.8	12	53	14	46	25	110	19	6
ES(M)31.5(F)	80	3	1.5	1.5	14.7	3.8	12	53	14	46	30	132	19	6
ES(M)22(F)	50	2	2	2	21.1	5.5	15	66	16	52	28	123	22	6
ES(M)32(F)	80	3	2	2	21.1	5.5	15	66	16	52	33	145	22	6

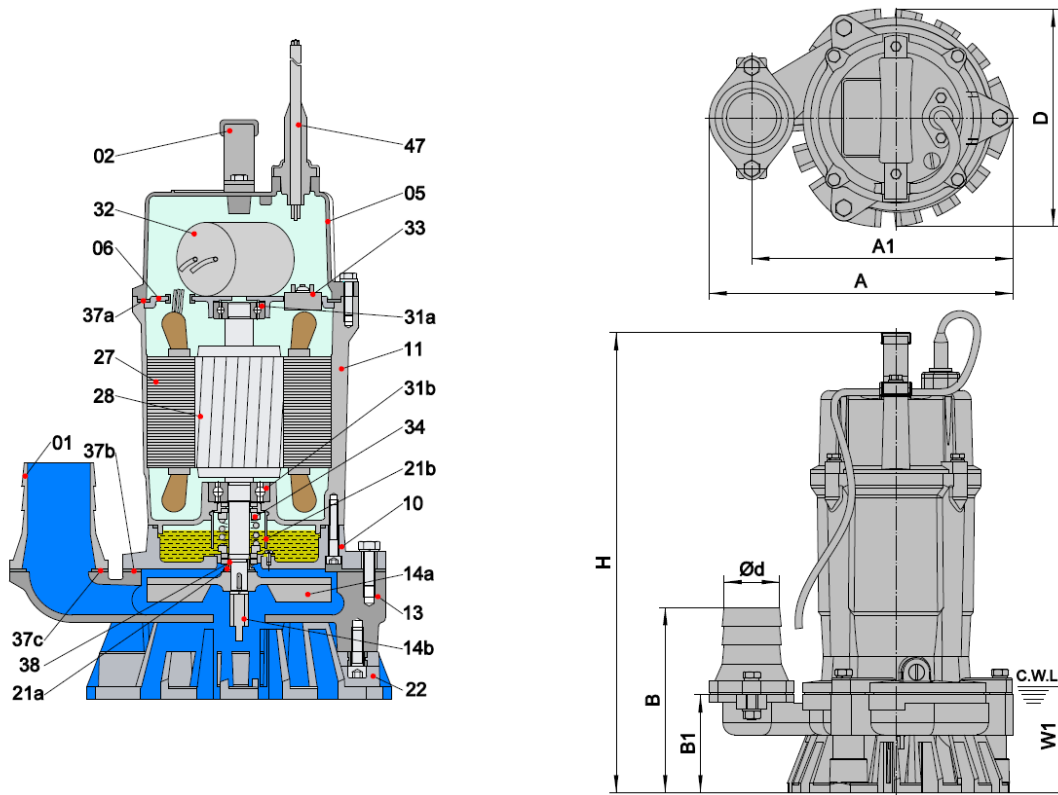

C.W.L: continuous running water level

## Materials of components

Item No.	Part name	Material	Item No.	Part name	Material
01	Hose coupling	Cast iron	27	Stator	
02	Handle	Rubber&steel	28	Rotor	Shaft:AISI420SS
05	Upper cover	Aluminum die casting	31a	Bearing	Ball bearing
06	Up-Bearing house	Cast iron	31b	Bearing	Ball bearing
10	Seal house	Cast iron	32	Capacitor	
11	Motor body	Aluminum die casting	33	Motor protector	
13	Pump body	Cast iron	34	Mechanical seal	Ceramic-Sic/Carbon-Ceramic
14a	Impeller	Ductile iron	37a	Gasket	NBR
14b	Agitator	Stainless steel	37b	Gasket	NBR
21a	Sand guard	NBR	37c	Gasket	NBR
21b	Oil riser	LDPE	38	Shaft sleeve	AISI420SS
22	Seat assembly	PU	47	Cable	H07RN-F

## DIMENSIONS & WEIGHTS

Model	d	A	A1	B	B1	D	H	W1	N.W	G.W	Packing dimensions
	mm	mm	mm	mm	mm	mm	mm	mm	Kg	Kg	
ES(M)2.6(F)	50	243	207	157	84	185	350	85	13.5	15	405x255x255
ES(M)21(F)	50	257	221	157	84	185	390	85	16.5	18	445x265x255
ES(M)31(F)	80	284	234	225	109	185	390	85	18	19.5	445x295x255
ES(M)21.5(F)	50	298	248	175	88	193	442	100	18.5	20	485x325x255
ES(M)31.5(F)	80	298	248	196	88	193	442	100	18.5	20	485x325x255
ES(M)22(F)	50	298	248	175	88	193	442	100	20.5	22	485x325x255
ES(M)32(F)	80	298	248	196	88	193	442	100	20.5	22	485x325x255

