

CABLE TRAYS

METAL TECH 
excellence delivered

Metal Tech Industries WLL

Factory No.3 Bldg 970, Road 5218, Block 952, Ras Zuwayed, Bahrain

Tel: 7731 5555 , Fax : 77314444, Cell: 32346666,38766940,39646453

E mail: sales@metaltechbahrain.com.

CABLE TRAYS

Metal Tech Cable trays are designed to meet most requirements of cable and electrical installation with compliance to local and international standards of fabrications.

Metal Tech Cable trays are made from Perforated Metal Sheets which has been later Hot Dip Galvanized for Longevity.

Metal Tech produces:

Straight run Cable Trays

Tee Sections

Elbow Sections

Reducer Sections.

Materials Used

1.50mm Mild Steel Hot Dip Galvanized *

Perforation Dimensions**

Perforation Sizes : 7mm WX 32mm L

Hole pitch : 25mm

Process:

Mild steel sheets perforated with Turrent Punching System further Fabricated with associated Shearing and press brakes to achieve the required dimensions. This is further Hot Dip Galvanized to reach final product finish.

* Different Thickness are available on request

** Different Pattern perforation available on request

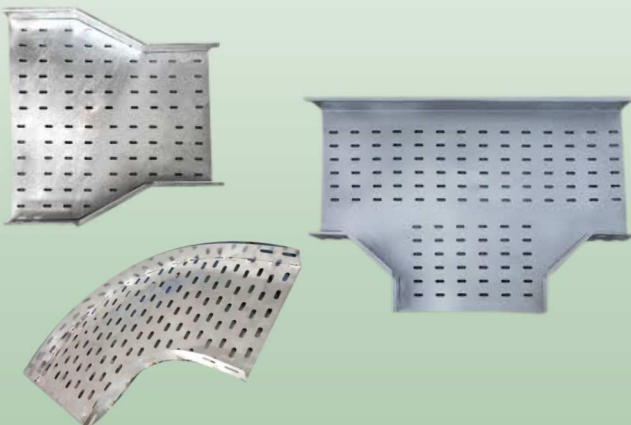

DIMENSIONAL DRAWINGS

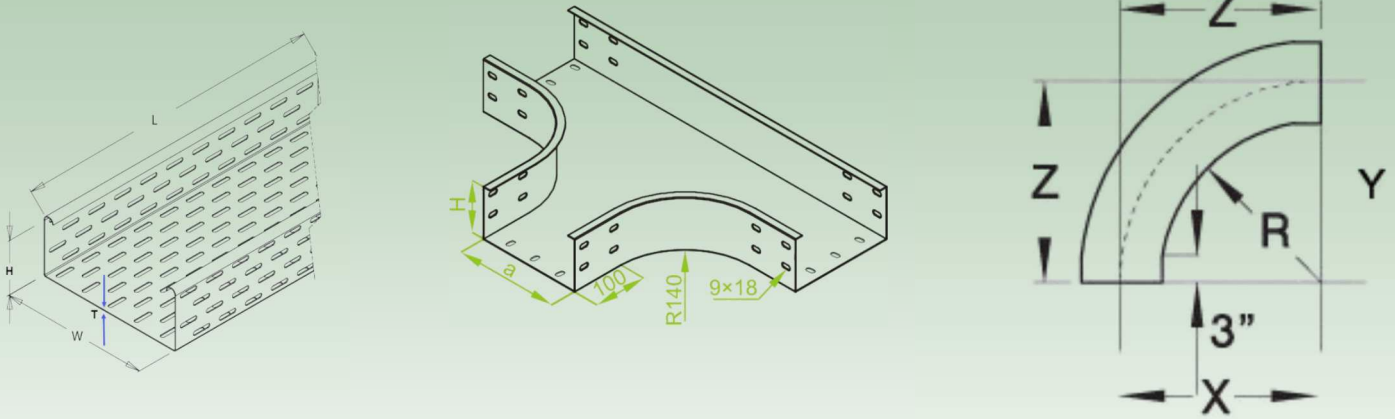

ORDERING METHOD— STRAIGHT RUN

MODEL—WIDTH(mm) X FLANGE(mm) X LENGTH(mm)X THICKNESS (mm)—QTY (NOS)

MTCT-S- 150MM X 50MM X 3000MM X1.50mm— 100 NOS

ORDERING METHOD— ELBOW , REDUCER, TEE

DETAILED SKETCH TO BE PROVIDED AS PER THE ABOVE DIMENSIONS DRAWINGS

CUSTOM DIMENSIONS ARE AVAILABLE FOR CABLE TRAYS, CABLE TRUNKING AND FITTINGS AS PER REQUEST.

