

General Guidance to the Safe Use of Container Lifting Lugs.

Document Reference: LEEA-066

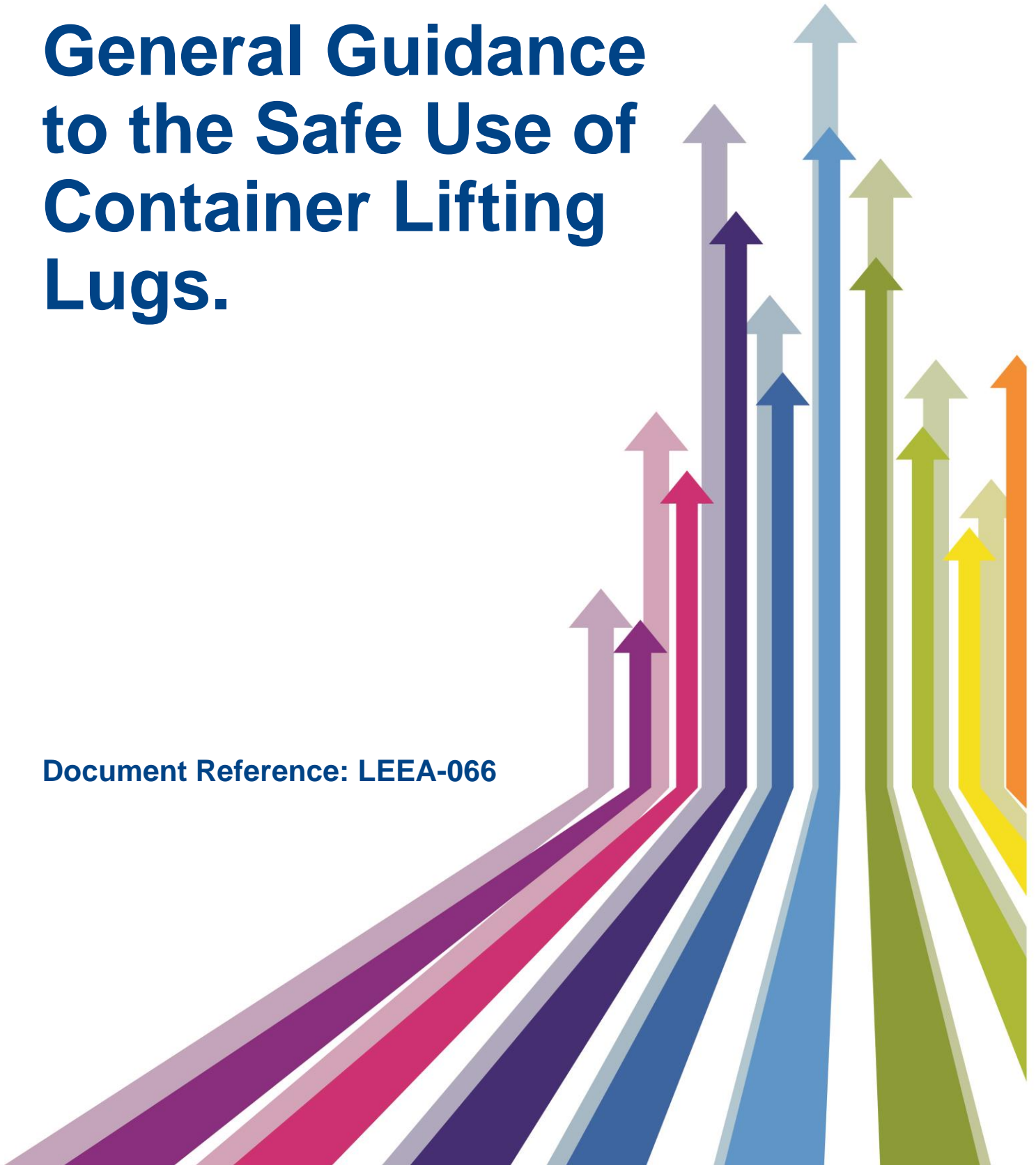

Intentionally Blank Page for
printing purposes only
Delete this box before printing



**General Guidance to the Safe Use of Container Lifting Lugs
Document reference; LEEA 066 Version 2, Dated 11/2021**

Disclaimer

The content of this guidance is provided for general information only. Whilst it is intended to represent a standard of good practice, it has no legal status and compliance with it does not exempt you from compliance with any legal requirements. If you require advice on your specific circumstances, please contact one of our advisors.

Although we make reasonable efforts to update the information in our guidance, we make no representations, warranties or guarantees, whether express or implied, that the content of our guidance is accurate, complete or up-to-date. It is the responsibility of those with specific duties under the legislation to ensure that they fulfil the obligations imposed on them.

Published by the
LIFTING EQUIPMENT ENGINEERS ASSOCIATION
3 Ramsay Court, Kingfisher Way
Hinchingsbrooke Business Park
Huntingdon PE29 6FY
United Kingdom
Tel: + 44 (0) 1480 432801
E-mail : Technical Support technicaladvice@leeaint.com
General enquiries mail@leeaint.com
Website: www.leeaint.com

CONTENTS

1.0	Introduction	Page 1
2.0	Standards and Legislation	Page 1
3.0	Types of Container Lifting Lugs	Page 1
3.1	Top Lifting Lugs	Page 1
3.2	Side Lifting Lugs	Page 2
3.3	Attaching container lugs to the load and the crane	Page 2
	3.3.1 Attaching the top container lugs to the load and crane	Page 2
	3.3.2 Attaching the side container lugs to the load and crane	Page 3
4.0	Storage and Handling	Page 4
5.0	Inspection, maintenance and thorough examination	Page 4
5.1	Inspection	Page 4
5.2	Maintenance	Page 4
5.3	Thorough Examination	Page 4
6.0	Documentation and Marking	Page 4
6.1	Manufacturers Certificate and/or EC Declarations of Conformity and Instructions for use.	Page 4
	6.1.1 Manufacturer's Certificate (LEEA-030.2e1 – 3 as applicable)	Page 4
	6.1.2 Instructions for Use	Page 5
6.2	Marking	Page 5
6.3	Training of Operatives	Page 5

1.0 Introduction.

Container lifting lugs are supplied in a variety of forms which offer the user a versatile and safe means of connecting a container to the lifting appliance. That is providing they are used in the correct manner and dangerous lifting practices are avoided. They are often, but must not be, confused with twist locks that are similar in construction, but have been designed solely for load restraint use, and as such are not suitable for lifting.

This guidance has therefore been developed as means of offering a general guidance to the variety of container lifting lugs available and their safe use.

Note: this guidance applies only to lugs that have been designed for use with ISO container boxes to ISO 1161:2016 Series 1 freight containers. Corner and intermediate fittings. Specifications

2.0 Standards and Legislation.

Container lifting lugs are classified as lifting accessories and fall within the scope of applicable national supply legislation. In the UK and Europe this legislation would require conformity assessment and conformity marking for these product types, see Supply of Machinery (Safety) Regulations 2008 and Machinery Directive 2006/42/EC respectively.

Once in service container lifting lugs fall under relevant under the relevant national user legislation. This legislation often specifies the requirements for inspection and maintenance, but in the absence of such legislation it is recommend that the LEEA *Code of practice for the Safe Use of Lifting Equipment* and LEEA Lifting Equipment Examiners guide are followed

Lifting twist locks are covered by ISO 1161 which specifies dimensions, materials, test requirements and marking for fixed and floating centre twist lock heads, and adjacent portions of the shank, used in lifting frames to lift freight containers or other equipment fitted with ISO corner fittings.

3.0 Types of container lugs.

There are a wide range of container lugs on the market and this guidance has been developed around the most common of these. It shall be noted that these guidance notes must also be read in conjunction with the manufacturer's instructions for use, that should be supplied with the equipment.

3.1 Top Lifting Lugs.

As the name suggests these lugs are designed to be fitted to the top of an ISO corner box. They are generally designed such that they can be inserted into the slot on the top of the corner box, then to secure they are twisted through 90 degrees and retained by a locking device. This particular type is commonly designed to be fitted to a vertical sling, therefore using this method of connecting to the load to the appliance will also require some sort of lifting frame and sling assembly. See figure 1 below for a typical example of a top lifting lug.



Figure 1: Typical top lifting lug (yellow)

Note: with certain types and/or size of container it is not permitted to use this method of lifting. For further guidance refer to ISO 3874 tables 1, 2, and 3 (Top lift spreaders).

3.2 Top or Bottom Side Lifting Lugs.

These items are designed to fit into the side of the ISO corner boxes. Some are designed specifically for the side of the top corner box, some for the bottom corner box and others can be fitted in either. Their shape allows them to be fitted into the ISO corner box side slot. Once fitted they are usually attached to one leg of 2 leg sling. The lug is rotated in the ISO corner box to the angle of the sling and a spring-loaded pin locks it in place, see figure 2 for a typical example.



Figure 2: Typical Side Lifting Lugs, showing top and bottom arrangements.

Note: with certain types and/or size of container it is not permitted to use this method of lifting. For further guidance refer to tables 1, 2, 4 (top lift slings) and 5 (bottom lift slings) of ISO 3874

3.3 Attaching the container lugs to the load and crane.

The connection of a container lug is always by means of a key that is inserted into one of the slots of an ISO container box. The key is then rotated through 90 degrees, such that it cannot be pulled out of the slot in the opposite direction to which it was inserted without rotating it. If there is potential for the key to rotate uncontrolled whilst in this position, then means must be provided to lock the key in the lifting position.

To connect the container lugs to the crane, use of other lifting accessories will be required and the type will depend on the type of lug being used, as the following sections will explain.

3.3.1 Attaching the top container lugs to the load and crane.

The method of connection to the load is generally as described in 3.3. However, since it is possible for the upper lug to move after being twisted into position, then it is vital that a locking device is used to secure it in place. Usually such a locking device is an integral drop-down pin that acts as a wedge in the socket, which prevents rotation until it is removed.

This type of container lifting lug is designed to be lifted from the vertical with an allowable tolerance of 15 degrees about the axis of the eye only, see figure 3. This means that they must be used in conjunction with a lifting frame and sling set. It is also recommended that the vertical slings on the frame are connected to the lug by means of a shackle with a nut, bolt and cotter pin to prevent shackle pin coming loose during the lifting operation.

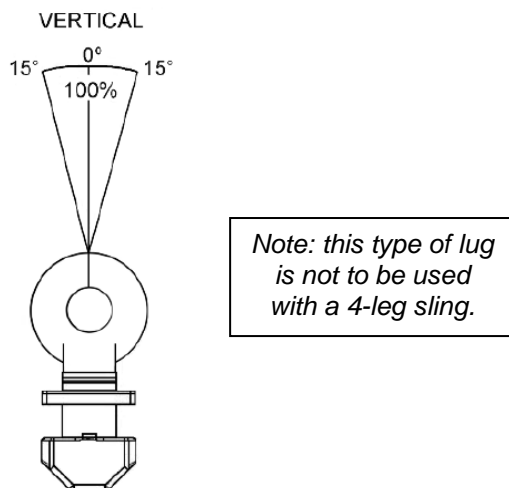

Figure 3: Top lug lifting tolerance.

It is also important to note that a shackle can only be loaded at an angle about the pin axis and therefore the shackle and container eye cannot be loaded to the side as this will put undue stress in the equipment, refer to figure 4.

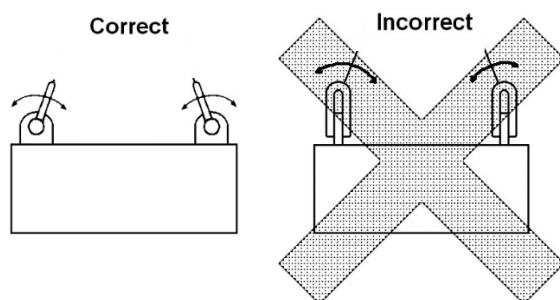

Figure 4: correct and incorrect shackle loading.

To avoid eccentric loading of the shackle, a loose spacer should be placed either side of the container lug, or a shackle with a smaller jaw width should be used. If a smaller shackle is used, ensure that the angle from the vertical is considered as this will increase the applied load.

Note: For further guidance on the slings, lifting frame and shackles refer to the Code of practice for the Safe Use of Lifting Equipment. Additional guidance on lifting frames can be found in LEEA 055 The Verification of Spreader Beams, Lifting Beams and Lifting Frames. Both of the documents are published by: Lifting Equipment Engineers' Association

3.3.2 Attaching the side container lugs to load and the crane

The method of connection to the load is generally as described in 3.3. However, since it is possible for the lug to move after being twisted into position, i.e. in the event of a slack sling leg, then it is vital that a locking device is used to secure it in place. Usually such a locking device is an integral spring actuated pin that acts as a wedge in the socket, which prevents rotation until it is released.

Most side container lugs can be used with vertical slings as described in 3.3.1, but they may also be used in conjunction with a sling at an angle. However, reference should be made to the manufacturer's instructions as there are some devices on the market that impose restrictions on the angle from the vertical. It is important to note that as the angle from the vertical increases then so does the load on the container lug. Therefore, the manufacturers load tables should be referred to in order to determine the maximum carrying capacity for the sling arrangement.

As with the top lifting lug, these lugs cannot be used with a 4-leg sling. Therefore, pairs, comprising a right-and-left-handed lug, are connected to a lifting beam via a 2-leg sling arrangement. The lug may also be connected to the sling by means of a shackle, but some are also designed to allow for

connection by means of the hook and safety catch, but this should be confirmed by reference to the manufacturer's instructions for use.

Note: For further guidance on the slings, lifting frame and shackles refer to the Code of practice for the Safe Use of Lifting Equipment (COPSULE). Additional guidance on lifting frames can be found in LEEA 055 The Verification of Spreader Beams, Lifting Beams and Lifting Frames. Both of the documents are published by: Lifting Equipment Engineers' Association

4.0 Storage and Handling.

It is recommended that wherever practicable, lifting lugs are not left in-situ, but should be removed after use and returned to proper storage. This storage area should be dry, free from injurious pollution and extremes of temperature.

5.0 Inspection, maintenance and thorough examination.

All lifting container lifting lugs fall within scope of national legislative requirements which require the lugs to undergo routine inspection, maintenance and thorough examination, as the following section explain.

5.1 Inspection

In addition to the thorough examination necessary under statutory provisions, all container lifting lugs should be visually inspected by a responsible person prior to use or on a regular basis, taking into account of the conditions of service. This inspection must be carried out with the container lug in a reasonably clean condition and in adequate lighting. If any of the following defects are present, the container lug should be withdrawn from service and referred to a Competent Person;

- distortion, such as bent shank or deformed eye;
- loss of section through excessive wear;
- damage such as nicks, cracks, gouges, corrosion;
- missing or illegible markings, such as the SWL, unique id, etc.

Note: Under NO circumstances should bent container lugs be straightened.

5.2 Maintenance

Maintenance of these items is low and would normally focus on the locking mechanism, however it is often more cost effective and safer to replace defective container lifting lugs rather than attempt a repair.

5.3 Thorough examination and inspection.

Container lifting lugs are only to be examined/inspected by a Competent Person who has such appropriate practical and theoretical knowledge and experience of the lifting equipment to be thoroughly examined as will enable them to detect defects or weaknesses and to assess their importance in relation to the safety and continued use of the lifting equipment.

6.0 Documentation and Marking

Container lifting lugs are classed as lifting accessories within the scope of national legislative requirements, which places obligations on the manufacturer to mark specific information on the product and supply it with defined documentation.

6.1 Manufacturers Certificate and/or Declarations of Conformity and Instructions for use.

For container lifting lugs these are the only documents that are required by national legislative requirements

6.1.1 Manufacturer's Certificate (LEEA-030.2e1 - 3 as applicable)

The Manufacturer's Certificate must contain the following information:

- The name and address of the manufacturer.
- The name and address of the manufacturers authorised representative.
- The name and address of the person responsible for compiling the technical file.
- Description of the equipment, type, serial number and WLL.
- The standards and specifications used.
- The place and date of the declaration.
- If a Declaration of Conformity is required then it must claim conformance with the essential health and safety requirements as defined in the Supply of Machinery (Safety) Regulations-

(SOM(S)R) or The EU Machinery Directive 2006/42/EC - please refer to LEEA 030.1e1 - 9 as applicable

- Name, position and signature of the person making the declaration.

6.1.2 Instructions for use.

Container Lifting Lugs must be supplied with instructions for use which must contain the following minimum information:

- Business name and full address of the manufacturer
- If required by the national supply legislation, a relevant Declaration of Conformity, showing the particulars of the container lifting lug, without the serial number and signatures.
- A general description of the container lifting lug.
- Drawings, diagrams, descriptions and explanations necessary for the assembly, use, maintenance and repair of the container lifting lug.
- A description of the intended use of the container lifting lug.
- Limits of use.
- Instructions for first use of the container lifting lug.
- Instructions regarding the need for training users.
- Information regarding residual risks that may remain despite inherent safe design.
- The conditions in which the lug meets the requirements for stability during use.
- A description of the maintenance operations that should be carried out by the user and the preventative maintenance measures that should be observed.
- The specifications of the spare parts that should be used when these affect the health and safety of the operators.
- The static test coefficient used.

Note: Refer to LEEA 062 General guidance to the Manufacturer of Lifting Equipment to the Development of Instructions for Use.

6.2 Marking

The container lifting lug must be marked with the following minimum information:

- The name and address of the manufacturer.
- Conformity mark if applicable, i.e. UKCA or CE marking for UK and EU markets
- The serial number.
- Year of construction.
- Maximum working load in tonnes or kilograms.

7.0 Training

Operative training shall be in accordance with section 1.9 of the LEEA Code of Practice for the Safe Use of Lifting Equipment. However, in addition to this the operative training should take the manufacturer's instructions into account, paying particular attention to the following:

- Operatives should be familiar with the type of container corner box and the appropriate holes for the type of lifting lug being used.
- Operatives should be shown the correct method of fitting and use of locking devices.
- Operatives should be shown the correct method of attachment to other lifting gear.
- Operatives should understand the rating of lifting lugs for angular loading.
- Operatives should understand the limitations of use with certain container types and sizes. (ISO 3874 tables 1, 2, 3, 4 and 5)