



The Wireless

December 2025

The Garden City

Amateur Radio Club

PO Box 482 • Garden City, MI 48135-9998



Next Meeting:
Tuesday, December 16, 2025
6:00pm
Deluca's Restaurant
27424 West Warren (at Inkster Rd.)
Westland, MI

December Meeting Holiday Dinner!

As we have often done, instead of a business meeting this month, we'll be meeting for dinner at Deluca's Restaurant. Deluca's is located on the northwest corner of Warren and Inkster Roads, with plenty of parking behind and on the west side of the building. There's no additional costs*, but you are responsible for your own check and tip. We'll start ordering about 6:00, but some of us will be there earlier if you just want to relax over your choice of hot or cold beverages. Family and friends are more than welcome to join us.

Please, please, please: if you haven't done so already, contact Scott, WT8S (Sdeykes@gmail.com) right away to let him know if you're coming. The restaurant needs a running update on our estimated head-count.

*(*unless Rich catches up with you and you haven't paid your '26 dues yet)*

2026 GCARC Club Officers:

- ◆ President Ralph Chrysler, KD8NFH, rockclimberralph591@gmail.com
- ◆ Vice President Roy Watts, W8ROY, wattsroyj@yahoo.com
- ◆ Treasurer Rich Zarczynski, AC8FJ, rzarczynski@yahoo.com
- ◆ Secretary Don Fellows, KC8VCX, donfellows331@gmail.com

Please feel free to contact any of your club officers with any comments, concerns, questions, suggestions, jokes, etc., any time.



**Thanks to W18X*

Mat-Matics # 125: Don's HF Antenna

M. Breton, N8TW

In 2020, I upgraded my HF antenna from a Hygain 18-AVT to a Hygain Omni DX-88. While the 18-AVT provided satisfactory performance, the DX-88 offered three additional operating bands, the capability to adjust the 80M resonance point from ground level without lowering the antenna, and a reduced radiation takeoff angle, consistent with its "DX" designation.

About trap antennas: Typically, a multi-band trap vertical antenna is a quarter-wave vertical design (technically multiple quarter-wave antennas) that features multiple LC traps inserted at intervals along its length. Each trap is tuned to a specific amateur radio band, such as 10 meters, 15 meters, or 20 meters. The antenna's ground system or radials serve as the return path for current, ensuring efficient operation across different bands.

This antenna works by using resonant traps—parallel LC circuits—that act like frequency-dependent switches. At their tuned frequency, the traps block RF current from traveling further up the antenna, making the antenna appear electrically shorter and resonant on that band. At other frequencies, the traps allow RF to pass, enabling operation on multiple bands with a single vertical radiator.

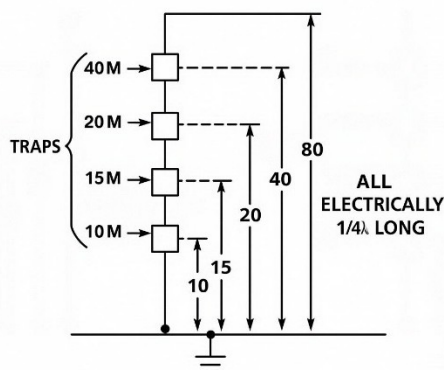

A multi-band trap vertical antenna enables operation on several amateur radio bands by incorporating resonant traps along its length. These traps are parallel LC circuits—consisting of an inductor and a capacitor—that function as frequency-dependent switches. At the trap's tuned frequency, it presents a high impedance, effectively blocking RF current from traveling further up the antenna. As a result, the antenna appears electrically shorter and resonates on that particular band. At non-resonant or lower frequencies, the reactance becomes predominantly inductive, and RF signals pass through with minimal resistance. The trap acts as a smart selector, adapting the antenna's electrical length as needed for each band.

While trap antennas allow multi-band functionality, they come with some side effects. The inclusion of traps reduces the antenna's physical height and overall efficiency—particularly as more traps are used. Bandwidth on certain bands may also be narrower due to the presence of traps.



Installation in Don's yard



Regarding the 18-AVT: The Hy-Gain 18-AVT is a five-band trap vertical antenna incorporating a base shunt, resulting in a DC-grounded configuration. Coverage of the 80-meter band is accomplished through the use of a top-loaded coil in conjunction with a capacitance top-hat. This omni-directional, self-supporting vertical radiator operates across the 10-, 15-, 20-, 40-, and 80-meter amateur radio bands. The antenna is designed for optimal performance when installed over earth ground or a resonant radial system in elevated applications.



Antenna (rotated 90 degrees)

The antenna can be optimized for phone or CW operation, on either ground or roof mounts. Its VSWR bandwidth supports 2:1 or better from 10 to 40 meters, though 80 meters has a narrower bandwidth due to top loading. Heavy-duty Hy-Q Traps enable automatic band selection by isolating antenna sections with parallel resonant circuits for true 1/4-wavelength resonance on all bands. The top hat and 80 meter resonator provide coverage on 80 meters via top loading, but the bandwidth is VERY narrow on 80M because of this.

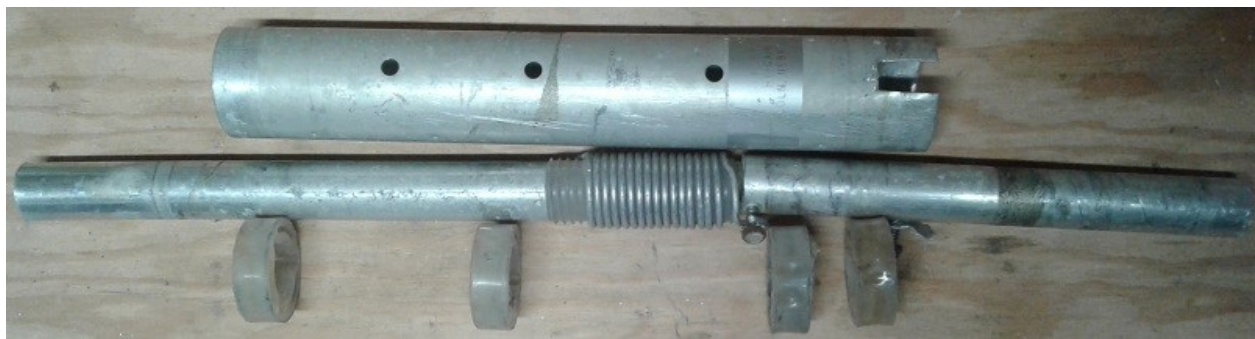

Example of a Hygain Trap

There were two major design iterations: an older version which used larger traps, and the more modern version with narrower traps. The version I had was the older version. The traps for these antenna are not tunable: they are fixed by design at the factory. Instead, the quarter-wave sections between the traps are varied in length by sliding tube sections like a trombone.

Antenna benefits:

- 1. Five bands
- 2. Very rugged/robust
- 3. Easy to trim/adjust

Antenna Limitations: no antenna is perfect, and the 18-AVT is no different. It has the following limitations:

- 1. No WARC bands (10,15,20,40,80M only)
- 2. 80M Bandwidth is very narrow, and frequency can only be adjusted by cutting the "whip" at the top.



.....

.....

.....

Initial repairs: When I received the antenna the trap covers (plastic) were rotted. Replacements were unavailable for the older version, so I made some out of schedule 80 plastic fittings. One trap had a broken plastic separator which I repaired, and the aluminum wire inside was broken which I also repaired. The 80M top inductor was completely re-wound with new wire as the original was not recoverable. The base DC shunt inductor was open, so I re-wound a new one.



Example of a rotted hy-gain trap seal

Original Install at my QTH: I installed and trimmed the antenna with no issues, and it served me well for many years. When I was able to get a Hy-Gain DX-88 antenna, I decided to “upgrade”. Since I paid nothing for the antenna, I wanted to find someone who could use it. Don, KC8VCX, was looking for a working HF antenna, and I was able to gift it to him and help him install it in his yard.

Takedown & Repair: I removed the antenna from my back yard and brought it into the garage. I resealed the DIY plastic trap covers. The top inductor I had rewound many years earlier had opened at a connection, so I repaired it. No other repairs or modifications were required. I put the antenna in my vehicle and brought it over to Don’s



Disassembled antenna (left), and open connection in top coil (right)

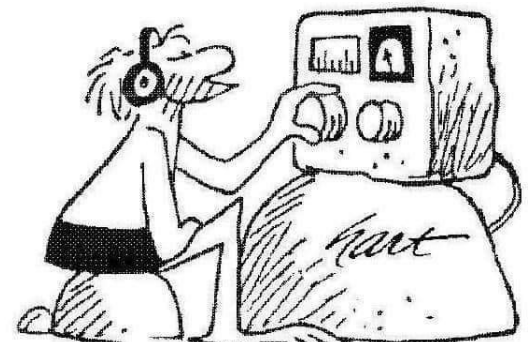

(c) 1994 Creators Syndicate, Inc.

.....

.....

.....

Initial Installation: Rich, W8DOW, donated feedline and also a stainless steel metal strut which we used for the base. We pounded the strut into the ground and attached the antenna with U-Bolts. (see photos on page 2)

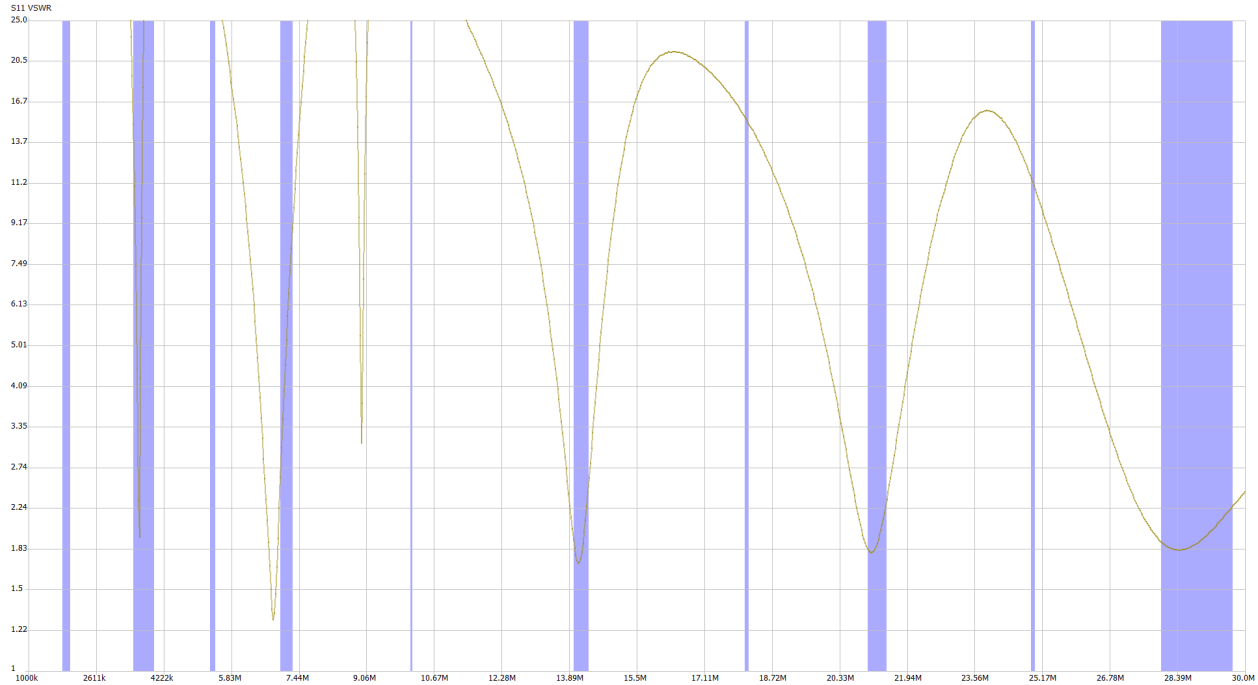

SWR plot 10M – 160M, initial installation at Don's

The 40M match was certainly a bit off, but the other band were usable. Other limitations:

1. The feedline was too short, so two pieces were joined with a sealed UHF-connector about 15' from the house, wrapped in plastic.
2. No radials were installed, which affects the antenna's impedance, efficiency, and takeoff angle; wet ground in Don's yard offers some compensation.

Follow-Up: About 3 years later, we returned to Don's for antenna upgrades. We re-trimmed the antenna to correct previous rough adjustments and drift over time. The matches were good on 10M, 15M, and 20M, and adequate with a tuner on 40M and 80M, likely due to fewer radials. We also redid the feedline connector in the middle and resealed it.

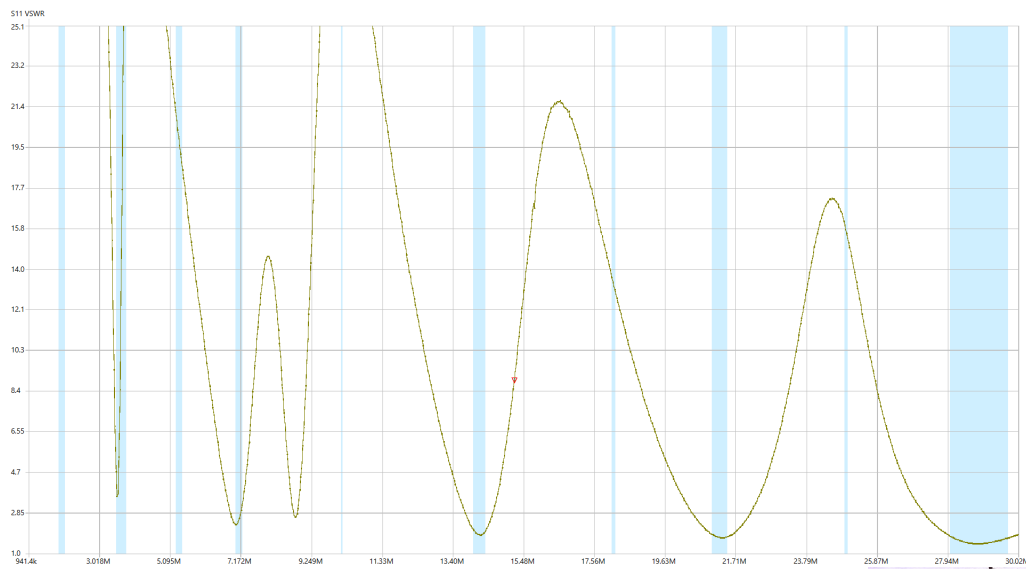

SWR plot after retrimming

