

螺纹接头

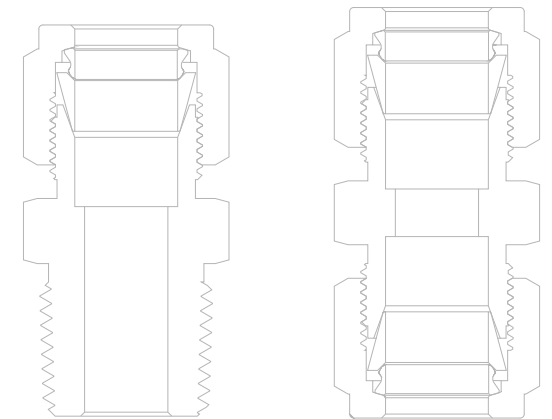

石油化工
煤化工
仪器仪表
新能源
电力
天然气



VFK

伟福克流体控制（江苏）有限公司
地址：江苏省丹阳市丹延路18号凤凰工业园区
Tel: 0511-86532352 传真: 0511-86535052
Http:// www.vfkgroup.com

VFK
Advanced Fluid Control

目录

螺纹堵头		04	45°阴阳螺纹弯通接头		20
内六角螺纹堵头		05	阴螺纹弯通接头		22
短管螺纹接头（双头丝）		06	45°阴螺纹弯通接头		23
长管螺纹接头（双头短节）		06	阳螺纹三通接头		24
六方阳螺纹接头		07	支管阴螺纹三通接头		25
加长六方阳螺纹接头		10	支管阳螺纹三通接头		25
大阳小阴螺纹接头（补芯）		11	主管阳螺纹三通接头		26
螺纹管帽		12	主管阴螺纹三通接头		26
阴螺纹活接头		13	阴螺纹三通接头		26
六方阴螺纹接头		14	大阴小阳螺纹接头（内外丝）		15
阳螺纹弯通接头		17	阴螺纹四通接头		27
阴阳螺纹弯通接头		18	异径活接头		27

特点

- 内外螺纹均经硬化处理，避免阴阳螺纹的咬死磨损，提高接头使用寿命。
- 圆弧的内部弯流通道，确保流体流动平稳。
- 每一个接头均标有材质和尺寸。

技术数据

螺纹端

螺纹类型	遵循标准
NPT	ASME B1.20.1, SAE AS71051
ISO锥螺纹	ISO 7-1, BS 21, JIS B0203
ISO直螺纹	ISO 228, JIS B0202
SAE/MS 螺纹	ASME B1.1, SAE J475
公制螺纹	ISO 261

工作温度

- 参考VFK卡套接头样本。

工作压力:

- 样本所示工作压力值是在室温下以 ANSI/ASME B31.3 为基准。当要按 ANSI/ASME B31.1 标准确定工作压力时，将样本所示的工作压力乘以下表中的系数。

材质	系数
不锈钢	0.94
碳钢	0.85
铜	1.0

- 要得到更高温度下的许用工作压力，用环境温度下的许用工作压力乘以升温系数。关于升温系数，请参阅 VFK 卡套接头样本。

材料代码表

材料	棒料	锻件	代码
316 不锈钢	ASTM A276, ASME SA479, EN 1.4401	ASTM A182, ASME SA182, EN 1.4401	SS
304 不锈钢	ASTM A276, ASME SA479, EN 1.4301	ASTM A182, ASME SA182, EN 1.4301	S4
合金 400/R-405	ASTM B164, ASME SB164	ASTM B564, ASME SB564	M
合金 600	ASTM B166, ASME SB166	ASTM B564, ASME SB564	INC
合金 C-276	ASTM B574	ASTM B564,	HC
铜	ASME B16/ASTM B453	ASTM B283	B
碳钢	ASTM A108	A105	CS

订购信息

- 完整的產品訂購號由材料信息、接頭類型、端口類型以及端口尺寸組成。
- 端口的優先順序按照以下原則：
 - 端口類別按以下順序描述：卡套（卡套穿板 > 公制 > 英制）—— 卡套管（公制 > 英制）—— 焊接（穿板 > 活接；承插焊 > 對焊；公制 > 英制）—— 螺紋（螺紋穿板 > NPT > BSPT > BSPP > AN > MS）
 - 螺紋類型相同時，按照陽螺紋在前，陰螺紋在後的順序描述
 - 接頭類型相同時，按照從大到小的順序描述
- 三通和四通的訂購號首先表示直通的尺寸（1和2），然後支管的尺寸（3和4）

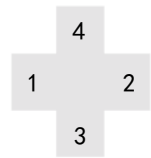

例：
一端為1/2 NPT 陰螺紋，另一端為1/4 RS 陽螺紋，材質為316不銹鋼的直通螺紋接頭，訂購號為：
SS21-FN84BS4

□ SS代表不銹鋼材料 □ 21代表直通接頭 □ FN8為1/2英寸NPT陰螺紋 □ BS4為1/4英寸RS陽螺紋

螺紋堵頭

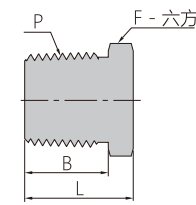

NPT 螺紋

P-NPT 尺寸	基本訂購號	尺寸, mm		
		L	F	B
1/16	26-N1	14.2	7.9	9.7
1/8	26-N2	14.2	11.1	9.7
1/4	26-N4	19.1	14.3	14.2
3/8	26-N6	19.8	17.5	14.2
1/2	26-N8	24.6	22.2	19.1
3/4	26-N12	30.7	27.0	19.1
1	26-N16	38.1	34.9	23.9
1-1/4	26-N20	38.4	44.5	23.9
1-1/2	26-N24	43.7	50.8	26.2
2	26-N32	50.6	69.9	26.2

ISO 錐陽螺紋

P-NPT 尺寸	基本訂購號	尺寸, mm		
		L	F	B
1/16	26-R1	14.2	7.9	9.7
1/8	26-R2	14.2	11.1	9.7
1/4	26-R4	19.1	14.3	14.2
3/8	26-R6	19.8	17.5	14.2
1/2	26-R8	24.6	22.2	19.1
3/4	26-R12	30.7	27.0	19.1
1	26-R16	38.1	34.9	23.9
1-1/4	26-R20	38.4	44.5	23.9
1-1/2	26-R24	43.7	50.8	26.2
2	26-R32	50.6	69.9	26.2

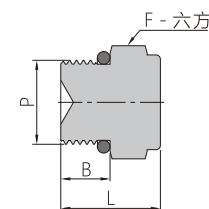

SAE/MS 陽螺紋

P-SAE/MS 螺紋 尺寸	基本訂購號	尺寸, mm		
		L	F	B
7/16-20	26-ST7	19.3	14.3	9.1
9/16-18	26-ST9	20.8	17.5	9.9
3/4-16	26-ST12	22.6	22.2	11.2
1-1/16-12	26-ST17	28.4	31.8	15.0
1-5/16-12	26-ST21	30.0	38.1	15.0

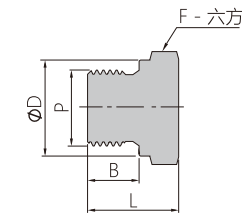

ISO 平行陽螺紋

P-RS 尺寸	基本訂購號	尺寸, mm			
		L	F	B	D
1/8	26-BS2	14.0	14.3	7.1	13.7
1/4	26-BS4	19.8	19.1	11.2	18.0
3/8	26-BS6	19.8	22.2	11.2	21.8
1/2	26-BS8	25.1	27.0	14.0	25.9
3/4	26-BS12	28.7	33.3	15.7	32.0
1	26-BS16	30.7	41.3	18.0	39.1

公制陽螺紋

P-公制螺紋 尺寸	基本訂購號	尺寸, mm			
		L	F	B	D
M14×1.5	26-MR14	21	20.6	12	18.8
M16×1.5	26-MR16	23	22.2	12	20.8
M18×1.5	26-MR18	25	23.8	12	22.8
M20×1.5	26-MR20	26.5	25.4	14	24.8
M22×1.5	26-MR22	28.5	28.6	14	26.8
M24×1.5	26-MR24	29	35.0	14	28.8
M27×1.5	26-MR27	30	36.5	16	31.8

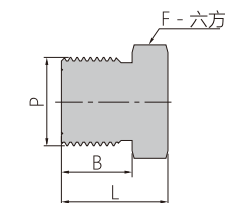

公制陽螺紋

P-公制螺紋 尺寸	基本訂購號	尺寸, mm		
		L	F	B
M14 x 1.5	26-MS14	18	16	13
M16 x 1.5	26-MS16	20	18	14
M18 x 1.5	26-MS18	22	19	15
M20 x 1.5	26-MS20	24	22	16
M22 x 1.5	26-MS22	26	24	17
M24 x 1.5	26-MS24	26	27	17
M27 x 2	26-MS27	27	30	18
M30 x 2	26-MS30	32	32	20

内六角螺纹堵头

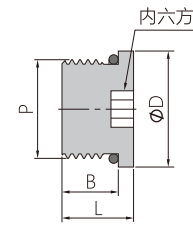
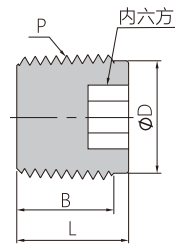

ISO 锥阳螺纹

P-RT 尺寸	基本订购号	尺寸, mm			
		L	F	B	D
1/16	261-R1	7.6	4.0	7.4	7.4
1/8	261-R2	10.4	4.8	7.4	9.4
1/4	261-R4	15.5	6.4	12.4	12.1
3/8	261-R6	15.5	7.9	12.4	15.7
1/2	261-R8	19.3	9.5	16.2	19.3
3/4	261-R12	19.8	14.3	16.7	25.7
1	261-R16	20.8	15.9	17.7	31.8

NPT 阳螺纹

P-NPT 尺寸	基本订购号	尺寸, mm			
		L	F	B	D
1/16	261-N1	7.6	4.0	7.4	7.4
1/8	261-N2	10.4	4.8	7.4	9.4
1/4	261-N4	15.5	6.4	12.4	12.1
3/8	261-N6	15.5	7.9	12.4	15.7
1/2	261-N8	19.3	9.5	16.2	19.3
3/4	261-N12	19.8	14.3	16.7	25.7
1	261-N16	20.8	15.9	17.7	31.8

SAE/MS 阳螺纹

P-SAE/ MS 螺纹 尺寸	基本订购号	尺寸, mm			
		L	F	B	D
7/16-20	261-ST7	11.4	4.8	9.1	14.2
9/16-18	261-ST9	12.2	6.4	9.9	17.5
3/4-16	261-ST12	14.2	7.9	11.2	22.4
1-1/16-12	261-ST17	19.1	14.3	15.0	31.8
1-5/16-12	261-ST21	19.1	15.9	15.0	38.1

短管阳螺纹接头(双头丝)

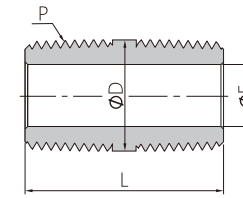

长管螺纹接头(双头短节)

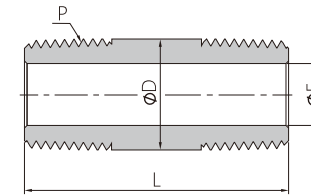

NPT 阳螺纹

P-NPT 尺寸	基本订购号	尺寸, mm			工作压力 psig (bar)
		L	D	E	
1/16	211-N1	19.1	7.9	3.0	11000 (757)
1/8	211-N2	19.1	10.3	4.8	10000 (689)
1/4	211-N4	28.4	13.7	7.1	8000 (551)
3/8	211-N6	28.4	17.1	9.6	7800 (537)
1/2	211-N8	38.1	21.3	11.9	7700 (530)
3/4	211-N12	38.1	26.7	15.7	7300 (502)
1	211-N16	47.8	33.4	22.4	5300 (365)

ISO 锥阳螺纹

P-RT 尺寸	基本订购号	尺寸, mm			工作压力 psig (bar)
		L	D	E	
1/16	211-N1	19.1	7.9	3.0	11000 (757)
1/8	211-N2	19.1	10.3	4.8	10000 (689)
1/4	211-N4	28.4	13.7	7.1	8000 (551)
3/8	211-N6	28.4	17.1	9.6	7800 (537)
1/2	211-N8	38.1	21.3	11.9	7700 (530)
3/4	211-N12	38.1	26.7	15.7	7300 (502)
1	211-N16	47.8	33.4	22.4	5300 (365)

NPT 阳螺纹

P-NPT 尺寸	基本订购号	尺寸, mm			工作压力 psig (bar)
		L	D	E	
1/8	211-N2-38.1	38.1	10.3	4.8	10000 (690)
1/8	211-N2-50.8	50.8	10.3	4.8	10000 (690)
1/8	211-N2-63.5	63.5	10.3	4.8	10000 (690)
1/8	211-N2-76.2	76.2	10.3	4.8	10000 (690)
1/4	211-N4-38.1	38.1	13.7	7.1	8000 (551)
1/4	211-N4-50.8	50.8	13.7	7.1	8000 (551)
1/4	211-N4-63.5	63.5	13.7	7.1	8000 (551)
1/4	211-N4-76.2	76.2	13.7	7.1	8000 (551)
1/4	211-N4-101.6	101.6	13.7	7.1	8000 (551)
3/8	211-N6-38.1	38.1	17.1	9.7	7800 (537)
3/8	211-N6-50.8	50.8	17.1	9.7	7800 (537)
3/8	211-N6-63.5	63.5	17.1	9.7	7800 (537)
3/8	211-N6-76.2	76.2	17.1	9.7	7800 (537)
3/8	211-N6-101.6	101.6	17.1	9.7	7800 (537)
1/2	211-N8-50.8	50.8	21.3	11.9	7700 (530)
1/2	211-N8-76.2	76.2	21.3	11.9	7700 (530)
1/2	211-N8-101.6	101.6	21.3	11.9	7700 (530)
1/2	211-N8-152.4	152.4	21.3	11.9	7700 (530)
3/4	211-N12-50.8	50.8	26.7	15.7	7300 (502)
3/4	211-N12-76.2	76.2	26.7	15.7	7300 (502)
3/4	211-N12-101.6	101.6	26.7	15.7	7300 (502)
1	211-N16-76.2	76.2	33.4	22.4	5300 (365)
1	211-N16-101.6	101.6	33.4	22.4	5300 (365)

六方阳螺纹接头

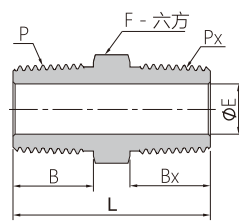

NPT 阳螺纹

P-NPT 尺寸	Px-NPT 尺寸	基本订购号	尺寸, mm					工作压力 psig (bar)
			L	F	B	Bx	E	316 不锈钢, 碳钢
1/16	1/16	21-N1	25.6	7.9	9.7	9.7	3.0	11000 (757)
1/8	1/16	21-N2N1	25.6	11.1	9.7	9.7	3.0	11000 (757)
1/8	1/8	21-N2	25.6	11.1	9.7	9.7	4.8	10000 (689)
1/4	1/16	21-N4N1	31.0	14.3	14.2	14.2	3.0	11000 (757)
1/4	1/8	21-N4N2	31.0	14.3	14.2	14.2	4.8	10000 (689)
1/4	1/4	21-N4	35.6	14.3	14.2	14.2	7.1	8000 (551)
3/8	1/16	21-N6N1	31.8	17.5	14.2	14.2	3.0	11000 (757)
3/8	1/8	21-N6N2	31.8	17.5	14.2	14.2	4.8	10000 (689)
3/8	1/4	21-N6N4	36.3	17.5	14.2	14.2	7.1	8000 (551)
3/8	3/8	21-N6	36.3	17.5	14.2	14.2	9.7	7800 (537)
1/2	1/8	21-N8N2	37.3	22.2	19.1	19.1	4.8	7700 (551)
1/2	1/4	21-N8N4	41.9	22.2	19.1	19.1	7.1	8000 (551)
1/2	3/8	21-N8N6	41.9	22.2	19.1	19.1	9.7	7800 (537)
1/2	1/2	21-N8	46.7	22.2	19.1	19.1	11.9	7700 (530)
3/4	1/8	21-N12N2	40.4	27.0	19.1	19.1	4.8	10000 (689)
3/4	1/4	21-N12N4	41.9	27.0	19.1	19.1	7.1	8000 (551)
3/4	3/8	21-N12N6	45.2	27.0	19.1	19.1	9.7	7800 (537)
3/4	1/2	21-N12N8	46.7	27.0	19.1	19.1	11.9	7700 (530)
3/4	3/4	21-N12	46.7	27.0	19.1	19.1	15.7	7300 (502)
1	1/8	21-N16N2	45.2	34.9	23.9	23.9	4.8	10000 (689)
1	1/4	21-N16N4	49.3	34.9	23.9	23.9	7.1	5300 (365)
1	3/8	21-N16N6	50.0	34.9	23.9	23.9	9.7	7800 (537)
1	1/2	21-N16N8	54.1	34.9	23.9	23.9	11.9	7700 (530)
1	3/4	21-N16N12	54.1	34.9	23.9	23.9	15.7	7300 (502)
1	1	21-N16	58.9	34.9	23.9	23.9	22.4	5300 (365)
1-1/4	1	21-N20N16	62.2	44.5	23.9	23.9	22.4	5300 (365)
1-1/4	1-1/4	21-N20	62.9	44.5	23.9	23.9	28.6	6000 (410)
1-1/2	1-1/2	21-N24	66.3	50.8	26.2	26.2	34.0	5000 (344)
2	2	21-N32	77.7	69.9	26.2	26.2	45.0	3900 (268)
厚壁 NPT 阳螺纹								
1/4	1/4	21-N4-10K	35.6	14.3	14.2	14.2	5.8	10000 (689)
1/2	1/4	21-N8N4-10K	41.9	22.2	19.1	14.2	5.8	10000 (689)
1/2	1/2	21-N8	46.7	22.2	19.1	19.1	9.9	10000 (689)

ISO 锥阳螺纹

P-RT 尺寸	Px-RT 尺寸	基本订购号	尺寸, mm					工作压力 psig (bar)
			L	F	B	Bx	E	316 不锈钢, 碳钢
1/8	1/8	21-R2	25.6	11.1	9.7	9.7	4.8	10000 (689)
1/4	1/4	21-R4	35.6	14.3	14.2	14.2	7.1	8000 (551)
3/8	3/8	21-R6	36.3	17.5	14.2	14.2	9.7	7800 (537)
1/2	1/2	21-R8	46.7	22.2	19.1	19.1	11.9	7700 (530)
3/4	3/4	21-R12	46.7	27.0	19.1	19.1	15.7	7300 (502)
1	1	21-R16	58.9	34.9	23.9	23.9	22.4	5300 (365)

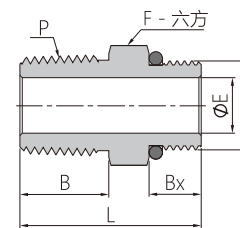
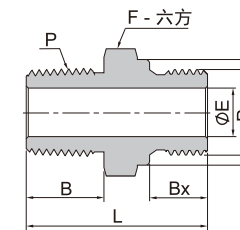
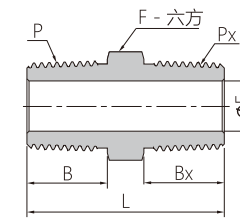

NPT 阳螺纹

P-NPT 尺寸	Px-RT 尺寸	基本订购号	尺寸, mm					工作压力 psig (bar)
			L	F	B	Bx	E	316 不锈钢, 碳钢
1/8	1/8	21-N2R2	25.6	11.1	9.7	9.7	4.8	10000 (689)
1/4	1/4	21-N4R4	35.6	14.3	14.2	14.2	7.1	8000 (551)
3/8	3/8	21-N6R6	36.3	17.5	14.2	14.2	9.7	7800 (537)
1/2	1/2	21-N8R8	46.7	22.2	19.1	19.1	11.9	7700 (530)
3/4	3/4	21-N12R12	46.7	27.0	19.1	19.1	15.7	7300 (502)
1	1	21-N16R16	58.9	34.9	23.9	23.9	22.4	5300 (365)

NPT 阳螺纹

P-NPT 尺寸	Px-RS 尺寸	基本订购号	尺寸, mm					工作压力 psig (bar)	
			L	F	B	Bx	E	D	316 不锈钢, 碳钢
1/8	1/8	21-N2BS2	27.7	14.3	9.7	7.1	4.1	13.7	11400 (785)
1/4	1/4	21-N4BS4	36.8	19.1	14.2	11.2	5.8	18.0	10300 (709)
3/8	3/8	21-N6BS6	37.6	22.2	14.2	11.2	7.9	21.6	10300 (709)
1/2	1/2	21-N8BS8	44.4	27.0	19.1	14.2	11.9	25.9	7600 (523)
3/4	3/4	21-N12BS12	49.0	33.3	19.1	15.7	15.7	32.0	7300 (502)
1	1	21-N16BS16	56.6	41.3	23.9	18.3	19.8	38.9	7400 (509)

NPT 阳螺纹

P-NPT 尺寸	Px-SAE/MS 螺纹尺寸	基本订购号	尺寸, mm					工作压力 psig (bar)
			L	F	B	Bx	E	316 不锈钢, 碳钢
1/4	7/16-20	21-N4ST7	30.5	14.3	14.2	9.1	5.1	4500 (310)
3/8	9/16-18	21-N6ST9	32.0	17.5	14.2	9.1	7.1	4500 (310)
1/2	3/4-16	21-N8ST12	38.9	22.2	19.1	11.2	10.7	4500 (310)
3/4	1-1/16-12	21-N12ST17	44.4	31.8	19.1	15.0	15.7	3600 (248)
1	1-5/16-12	21-N16ST21	50.8	38.1	23.9	15.0	22.4	2900 (199)

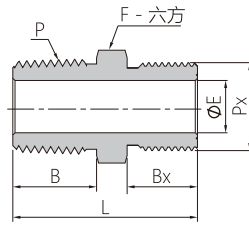

NPT 阳螺纹

P-NPT 尺寸	Px- 螺纹尺寸	基本订购号	尺寸, mm					工作压力 psig (bar)
			L	F	B	Bx	E	316 不锈钢, 碳钢
1/8	M20×1.5	21-N2MS20	32.7	22.2	9.7	16.0	5.0	7000 (530)
1/4	M8×1	21-N4MS8	29.0	14.3	14.2	9.0	3.2	8000 (551)
1/4	M14×1.5	21-N4MS14	34.2	15.9	14.2	12.0	7.0	8000 (551)
1/4	M16×1.5	21-N4MS16	35.2	17.5	14.2	14.0	7.1	7800 (537)
1/4	M20×1.5	21-N4MS20	37.2	22.2	14.2	16.0	7.0	7700 (530)
3/8	M14×1.5	21-N6MS14	34.2	17.5	14.2	13.0	7.0	7800 (537)
3/8	M20×1.5	21-N6MS20	37.2	22.2	14.2	16.0	9.5	7700 (530)
3/8	M24×1.5	21-N6MS24	38.2	27.0	14.2	17.0	9.5	7400 (509)
1/2	M14×1.5	21-N8MS14	39.1	22.2	19.1	13.0	7.0	7700 (530)
1/2	M20×1.5	21-N8MS20	42.0	22.2	19.1	16.0	10.0	7700 (530)
1/2	M24×1.5	21-N8MS24	43.5	27.0	19.1	17.0	11.9	7400 (509)
3/4	M20×1.5	21-N12MS20	42.1	27.0	19.1	16.0	10.0	7300 (502)
3/4	M27×2	21-N12MS27	46.7	31.8	19.1	18.0	15.8	6100 (420)
1	M30×2	21-N16MS30	55.0	34.9	23.9	20.0	11.9	6100 (420)

公制阳螺纹

加长六方阳螺纹接头

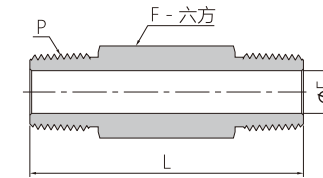

NPT 阳螺纹

P-NPT 尺寸	基本订购号	尺寸, mm			工作压力 psig (bar)
		L	F	E	316 不锈钢, 碳钢
1/8	21-N2-38.1	38.1	11.1	4.8	10000 (690)
1/8	21-N2-50.8	50.8	11.1	4.8	10000 (690)
1/8	21-N2-63.5	63.5	11.1	4.8	10000 (690)
1/8	21-N2-76.2	76.2	11.1	4.8	10000 (690)
1/4	21-N4-38.1	38.1	14.3	7.1	8000 (551)
1/4	21-N4-50.8	50.8	14.3	7.1	8000 (551)
1/4	21-N4-63.5	63.5	14.3	7.1	8000 (551)
1/4	21-N4-76.2	76.2	14.3	7.1	8000 (551)
1/4	21-N4-101.6	101.6	14.3	7.1	8000 (551)
3/8	21-N6-38.1	38.1	17.5	9.7	7800 (537)
3/8	21-N6-50.8	50.8	17.5	9.7	7800 (537)
3/8	21-N6-63.5	63.5	17.5	9.7	7800 (537)
3/8	21-N6-76.2	76.2	17.5	9.7	7800 (537)
3/8	21-N6-101.6	101.6	17.5	9.7	7800 (537)
1/2	21-N8-50.8	50.8	22.2	11.9	7700 (530)
1/2	21-N8-76.2	76.2	22.2	11.9	7700 (530)
1/2	21-N8-101.6	101.6	22.2	11.9	7700 (530)
1/2	21-N8-152.4	152.4	22.2	11.9	7700 (530)
3/4	21-N12-50.8	50.8	27.0	15.7	7300 (502)
3/4	21-N12-76.2	76.2	27.0	15.7	7300 (502)
3/4	21-N12-101.6	101.6	27.0	15.7	7300 (502)
1	21-N16-76.8	76.2	34.9	22.4	5300 (365)
1	21-N16-101.6	101.6	34.9	22.4	5300 (365)

ISO 锥阳螺纹

P-RT 尺寸	Px- 螺纹尺寸	基本订购号	尺寸, mm					工作压力 psig (bar)
			L	F	B	Bx	E	316 不锈钢, 碳钢
1/8	M20 x 1.5	21-R2MS20	32.7	32.7	22.2	16.0	5.0	7700 (530)
1/4	M12 x 1.5	21-R4MS12	33.4	33.4	14.3	15.0	5.0	8000 (551)
1/4	M20 x 1.5	21-R4MS20	37.2	37.2	22.2	16.0	7.0	7700 (530)
3/8	M20 x 1.5	21-R6MS20	37.2	37.2	22.2	16.0	9.5	7700 (530)
1/2	M20 x 1.5	21-R8MS20	42.0	42.0	22.2	16.0	10.0	7700 (530)

公制阳螺纹

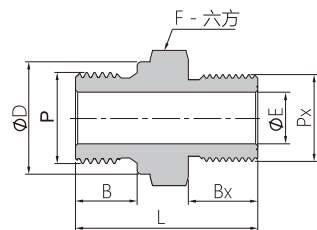

ISO 平行阳螺纹

P-RS 尺寸	Px- 公制螺纹尺寸	基本订购号	尺寸, mm						工作压力 psig (bar)
			L	F	B	Bx	E	D	316 不锈钢, 碳钢
1/8	M20 x 1.5	21-BS2MS20	30.1	22.2	7.1	16.0	4.0	13.7	7700 (530)
1/4	M12 x 1.5	21-BS4MS18	34.2	20.6	11.2	15.0	5.9	18.0	7800 (537)
1/4	M20 x 1.5	21-BS4MS20	36.2	22.2	11.2	16.0	5.9	18.0	7700 (530)
3/8	M20 x 1.5	21-BS6MS20	36.2	22.2	11.2	16.0	7.9	21.6	7700 (530)
1/2	M20 x 1.5	21-BS8MS20	40.2	22.2	14.0	16.0	11.9	25.9	7700 (530)

公制阳螺纹

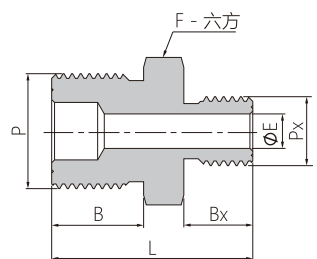

公制阳螺纹

P- 公制螺纹尺寸	Px- 公制螺纹尺寸	基本订购号	尺寸, mm					工作压力 psig (bar)
			L	F	B	Bx	E	316 不锈钢, 碳钢
M20 x 1.5	M10 x 1	21-MS20MS10	34.0	22.2	16.0	11.0	4.0	10000 (690)
M20 x 1.5	M12 x 1.5	21-MS20MS12	35.0	22.2	16.0	12.0	6.0	9000 (620)
M20 x 1.5	M14 x 1.5	21-MS20MS14	36.0	22.2	16.0	13.0	8.0	8000 (551)
M20 x 1.5	M16 x 1.5	21-MS20MS16	37.0	22.2	16.0	14.0	9.0	7800 (537)
M20 x 1.5	M20 x 1.5	21-MS20	39.0	22.2	16.0	16.0	10.0	7700 (530)
M27 x 2	M27 x 2	21-MS27	44.5	30.1	18.0	18.0	14.0	7300 (502)

ISO 锥阳螺纹

P-RT 尺寸	基本订购号	尺寸, mm			工作压力 psig (bar)
		L	F	E	316 不锈钢, 碳钢
1/8	21-R2-38.1	38.1	11.1	4.8	10000 (690)
1/8	21-R2-50.8	50.8	11.1	4.8	10000 (690)
1/8	21-R2-63.5	63.5	11.1	4.8	10000 (690)
1/8	21-R2-76.2	76.2	11.1	4.8	10000 (690)
1/4	21-R4-38.1	38.1	14.3	7.1	8000 (551)
1/4	21-R4-50.8	50.8	14.3	7.1	8000 (551)
1/4	21-R4-63.5	63.5	14.3	7.1	8000 (551)
1/4	21-R4-76.2	76.2	14.3	7.1	8000 (551)
1/4	21-R4-101.6	101.6	14.3	7.1	8000 (551)
3/8	21-R6-38.1	38.1	17.5	9.7	7800 (537)
3/8	21-R6-50.8	50.8	17.5	9.7	7800 (537)
3/8	21-R6-63.5	63.5	17.5	9.7	7800 (537)
3/8	21-R6-76.2	76.2	17.5	9.7	7800 (537)
3/8	21-R6-101.6	101.6	17.5	9.7	7800 (537)
1/2	21-R8-50.8	50.8	22.2	11.9	7700 (530)
1/2	21-R8-76.2	76.2	22.2	11.9	7700 (530)
1/2	21-R8-101.6	101.6	22.2	11.9	7700 (530)
1/2	21-R8-152.4	152.4	22.2	11.9	7700 (530)
3/4	21-R12-50.8	50.8	27.0	15.7	7300 (502)
3/4	21-R12-76.2	76.2	27.0	15.7	7300 (502)
3/4	21-R12-101.6	101.6	27.0	15.7	7300 (502)
1	21-R16-76.8	76.2	34.9	22.4	5300 (365)
1	21-R16-101.6	101.6	34.9	22.4	5300 (365)

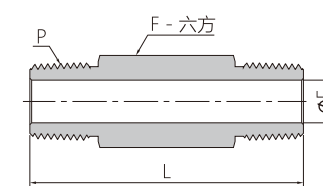

大阳小阴螺纹接头 (补芯)

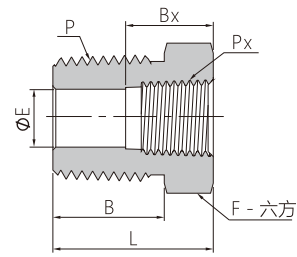

NPT 阳螺纹			NPT 阴螺纹						
P-NPT 尺寸	Px-NPT 尺寸	基本订购号	尺寸, mm					工作压力 psig (bar)	
			L	F	B	Bx	E	316 不锈钢, 碳钢	
1/8	1/16	21-N2FN1	26.2	11.1	9.7	9.9	4.8	6500 (447)	
1/4	1/16	21-N4FN1	21.8	14.3	14.2	9.9	4.8	8000 (551)	
1/4	1/8	21-N4FN2	26.9	14.3	14.2	10.4	7.1	6500 (447)	
3/8	1/16	21-N6FN1	21.8	17.5	14.2	9.9	4.8	13300 (971)	
3/8	1/8	21-N6FN2	21.8	17.5	14.2	10.4	8.6	9200 (633)	
3/8	1/4	21-N6FN4	30.2	19.1	14.2	15.0	9.6	6600 (454)	
1/2	1/8	21-N8FN2	27.4	22.2	19.1	10.4	8.6	12200 (840)	
1/2	1/4	21-N8FN4	27.4	22.2	19.1	15.0	11.4	8300 (571)	
1/2	3/8	21-N8FN6	35.8	22.2	19.1	15.0	11.9	5300 (365)	
3/4	1/8	21-N12FN2	27.4	27.0	19.1	10.4	7.1	20000 (1378)	
3/4	1/4	21-N12FN4	27.4	27.0	19.1	15.0	11.4	12000 (826)	
3/4	3/8	21-N12FN6	27.4	27.0	19.1	15.0	15.0	8200 (564)	
3/4	1/2	21-N12FN8	41.4	27.0	19.1	19.8	15.7	4900 (337)	
1	1/8	21-N16FN2	34.5	34.9	23.9	10.4	7.1	20000 (1378)	
1	1/4	21-N16FN4	34.8	34.9	23.9	15.0	11.4	14500 (999)	
1	3/8	21-N16FN6	34.8	34.9	23.9	15.0	15.0	11600 (799)	
1	1/2	21-N16FN8	34.8	34.9	23.9	19.8	18.5	8600 (592)	
1	3/4	21-N16FN12	47.0	34.9	23.9	20.6	22.4	5300 (365)	
1-1/4	3/4	21-N20FN12	37.3	44.5	23.9	20.6	22.4	7800 (537)	
1-1/4	1	21-N20FN16	37.3	44.5	23.9	25.4	22.4	3500 (241)	
1-1/2	1	21-N24FN16	40.1	50.8	26.2	25.4	22.4	6600 (454)	
1-1/2	1-1/4	21-N24FN20	56.0	54.0	26.2	25.4	34.0	5000 (344)	

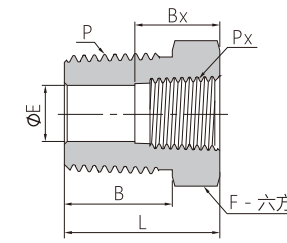

ISO 锥阳螺纹			尺寸, mm					工作压力 psig (bar)
P-RT 尺寸	Px-RT 尺寸	基本订购号	L	F	B	Bx	E	316 不锈钢, 碳钢
			1/4	1/8	21-R4FR2	26.9	14.3	14.2
3/8	1/4	21-R6FR4	30.2	19.1	14.2	15.0	9.6	6600 (454)
1/2	1/4	21-R8FR4	27.4	22.2	19.1	15.0	11.2	8300 (571)
1/2	3/8	21-R8FR6	35.8	22.2	19.1	15.0	11.9	5300 (365)

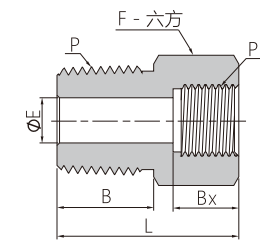

NPT 锥阳螺纹			尺寸, mm					工作压力 psig (bar)
P-NPT 尺寸	Px-RG 尺寸	基本订购号	L	F	B	Bx	E	316 不锈钢, 碳钢
			3/8	1/4	21-N6FG4	30.2	19.1	14.2
1/2	3/8	21-N8FG6	35.8	22.2	19.1	14.2	6.6	5700 (392)
3/4	1/2	21-N12FG8	41.4	27.0	19.1	18.8	7.1	3900 (268)

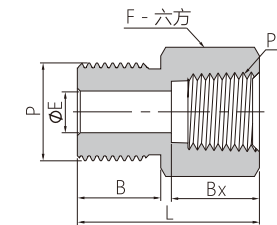

ISO 平行阳螺纹			尺寸, mm					工作压力 psig (bar)
P-BP 尺寸	Px-NPT 尺寸	基本订购号	L	F	B	Bx	E	316 不锈钢, 碳钢
			1/4	1/8	21-BP4FN2	26.9	14.3	12.9
3/8	1/4	21-BP6FN4	31.0	19.1	14.2	15.0	7.1	6600 (454)
1/2	3/8	21-BP8FN6	35.8	22.2	18.8	15.0	6.6	5300 (365)

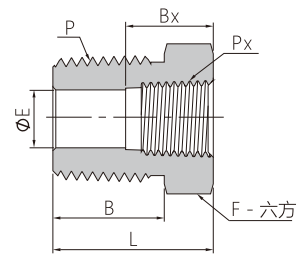

NPT 阳螺纹			ISO 锥阴螺纹						
P-NPT 尺寸	Px-RT 尺寸	基本订购号	尺寸, mm					工作压力 psig (bar)	
			L	F	B	Bx	E	316 不锈钢, 碳钢	
1/8	1/16	21-N2FR1	26.2	11.1	9.7	9.9	4.8	6500 (447)	
1/4	1/16	21-N4FR1	21.8	14.3	14.2	9.9	4.8	8000 (551)	
1/4	1/8	21-N4FR2	26.9	14.3	14.2	10.4	7.1	6500 (447)	
3/8	1/16	21-N6FR1	21.8	17.5	14.2	9.9	4.8	13300 (971)	
3/8	1/8	21-N6FR2	21.8	17.5	14.2	10.4	8.6	9200 (633)	
3/8	1/4	21-N6FR4	30.2	19.1	14.2	15.0	9.6	6600 (454)	
1/2	1/8	21-N8FR2	27.4	22.2	19.1	10.4	8.6	12200 (840)	
1/2	1/4	21-N8FR4	27.4	22.2	19.1	15.0	11.4	8300 (571)	
1/2	3/8	21-N8FR6	35.8	22.2	19.1	15.0	11.9	5300 (365)	
3/4	1/8	21-N12FR2	27.4	27.0	19.1	10.4	7.1	20000 (1378)	
3/4	1/4	21-N12FR4	27.4	27.0	19.1	15.0	11.4	12000 (826)	
3/4	3/8	21-N12FR6	27.4	27.0	19.1	15.0	15.0	8200 (564)	
3/4	1/2	21-N12FR8	41.4	27.0	19.1	19.8	15.7	4900 (337)	
1	1/8	21-N16FR2	34.5	34.9	23.9	10.4	7.1	20000 (1378)	
1	1/4	21-N16FR4	34.8	34.9	23.9	15.0	11.4	14500 (999)	
1	3/8	21-N16FR6	34.8	34.9	23.9	15.0	15.0	11600 (799)	
1	1/2	21-N16FR8	34.8	34.9	23.9	19.8	18.5	8600 (592)	
1	3/4	21-N16FR12	47.0	34.9	23.9	20.6	22.4	5300 (365)	
1-1/4	3/4	21-N20FR12	37.3	44.5	23.9	20.6	22.4	7800 (537)	
1-1/4	1	21-N20FR16	37.3	44.5	23.9	25.4	22.4	3500 (241)	
1-1/2	1	21-N24FR16	40.1	50.8	26.2	25.4	22.4	6600 (454)	
1-1/2	1-1/4	21-N24FR20	56.0	54.0	26.2	25.4	34.0	5000 (344)	

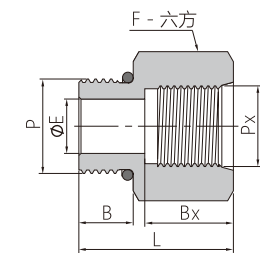

SAE 阳螺纹			尺寸, mm					工作压力 psig (bar)
P-SAE/MS 螺纹 尺寸	Px-SAE/MS 螺纹 尺寸	基本订购号	L	F	B	Bx	E	316 不锈钢, 碳钢
			9/16-18	7/16-20	21-ST9FST7	28.4	20.6	9.9
3/4-16	7/16-20	21-ST12FST7	24.9	22.2	11.2	14.0	9.9	4500 (310)
3/4-16	9/16-18	21-ST12FST9	30.2	25.4	11.2	16.0	10.7	4500 (310)
7/8-14	9/16-18	21-ST14FST9	27.9	25.4	12.7	16.0	12.7	3600 (248)
7/8-14	3/4-16	21-ST14FST12	36.1	30.2	12.7	18.0	12.7	3600 (248)
1-1/16-12	3/4-16	21-ST17FST12	32.3	31.8	15.0	18.0	16.5	3600 (248)
1-5/16-12	1-1/16-12	21-ST21FST17	40.9	41.3	15.0	24.0	22.1	2900 (199)
1-5/8-12	1-5/16-12	21-ST26FST21	50.3	54.0	15.0	24.0	27.7	2300 (158)
1-7/8-12	1-5/16-12	21-ST30FST21	50.3	54.0	15.0	24.0	31.2	2300 (158)

螺纹管帽

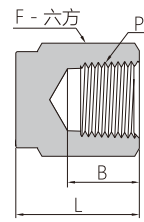

NPT 阴螺纹

P-NPT 尺寸	基本订购号	尺寸, mm			工作压力 psig (bar)
		L	F	B	
1/16	26-FN1	12.7	11.1	9.9	6700 (460)
1/8	26-FN2	19.1	14.3	10.4	6500 (447)
1/4	26-FN4	23.1	19.1	15.0	6600 (454)
3/8	26-FN6	26.2	22.2	15.0	5300 (365)
1/2	26-FN8	34	27.0	19.8	4900 (337)
3/4	26-FN12	36.6	33.3	20.6	4600 (316)
1	26-FN16	41.1	41.3	25.4	4400 (303)
厚壁NPT 阴螺纹					
1/4	26-FN4-10K	28.2	25.4	15.0	10000 (689)
1/2	26-FN8-10K	40.1	38.1	19.8	10000 (689)

ISO 锥阴螺纹

P-FR 尺寸	基本订购号	尺寸, mm			工作压力 psig (bar)
		L	F	B	
1/16	26-FR1	12.7	11.1	9.9	6700 (460)
1/8	26-FR2	19.1	14.3	10.4	6500 (447)
1/4	26-FR4	23.1	19.1	15.0	6600 (454)
3/8	26-FR6	26.2	22.2	15.0	5300 (365)
1/2	26-FR8	34.0	27.0	19.8	4900 (337)
3/4	26-FR12	36.6	33.3	20.6	4600 (316)
1	26-FR16	41.1	41.3	25.4	4400 (303)

阴螺纹活接头

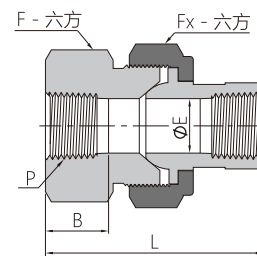

NPT 阴螺纹

P-NPT 尺寸	基本订购号	尺寸, mm					工作压力 psig (bar)
		L	F	Fx	B	E	
1/8	21-UBJ-FN2	46.0	23.8	28.6	10.4	6.8	8400 (578)
1/4	21-UBJ-FN4	59.4	30.2	34.9	15.0	9.1	6600 (454)
3/8	21-UBJ-FN6	63.5	33.3	38.1	15.0	13.2	5300 (365)
1/2	21-UBJ-FN8	68.3	41.3	44.5	19.8	15.7	6000 (410)
3/4	21-UBJ-FN12	79.2	47.6	54.0	20.6	22.4	4600 (316)
1	21-UBJ-FN16	90.4	60.3	63.5	25.4	26.2	6800 (468)

ISO 锥阴螺纹

P-RT 尺寸	基本订购号	尺寸, mm					工作压力 psig (bar)
		L	F	Fx	B	E	
1/8	21-UBJ-FR2	46.0	23.8	28.6	10.4	6.8	8400 (578)
1/4	21-UBJ-FR4	59.4	30.2	34.9	15.0	9.1	6600 (454)
3/8	21-UBJ-FR6	63.5	33.3	38.1	15.0	13.2	5300 (365)
1/2	21-UBJ-FR8	68.3	41.3	44.5	19.8	15.7	6000 (410)
3/4	21-UBJ-FR12	79.2	47.6	54.0	20.6	22.4	4600 (316)
1	21-UBJ-FR16	90.4	60.3	63.5	25.4	26.2	6800 (468)

六方阴螺纹接头

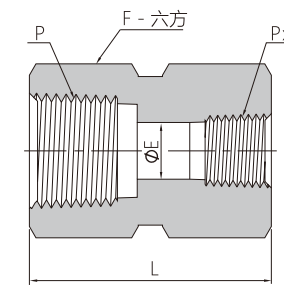

NPT 阴螺纹接头

P-NPT 尺寸	Px-NPT 尺寸	基本订购号	尺寸, mm			工作压力 psig (bar)
			L	F	E	
1/16	1/16	21-FN1	19.8	11.1	4.8	6700 (460)
1/8	1/8	21-FN2	20.6	14.3	8.6	6500 (447)
1/4	1/8	21-FN4FN2	31.0	19.1	8.6	6600 (454)
1/4	1/4	21-FN4	30.2	19.1	11.4	6600 (454)
3/8	1/4	21-FN6FN4	35.1	22.2	11.4	5300 (365)
3/8	3/8	21-FN6	33.3	27.0	15.0	5300 (365)
1/2	1/8	21-FN8FN2	39.6	27.0	8.6	4900 (337)
1/2	1/4	21-FN8FN4	44.4	27.0	11.4	4900 (337)
1/2	3/8	21-FN8FN6	45.2	27.0	15.0	4900 (337)
1/2	1/2	21-FN8	39.6	27.0	18.5	4900 (337)
3/4	1/4	21-FN12FN4	46.0	33.3	11.4	4600 (316)
3/4	1/2	21-FN12FN8	52.3	33.3	18.5	4600 (316)
3/4	3/4	21-FN12	41.1	33.3	23.9	4600 (316)
1	1/2	21-FN16FN8	55.6	41.3	18.5	4400 (303)
1	3/4	21-FN16FN12	57.2	41.3	23.9	4400 (303)
1	1	21-FN16	50.8	41.3	29.7	4400 (303)
厚壁NPT 阴螺纹						
1/4	1/4	21-FN4-10K	30.2	25.4	11.4	10000 (689)
1/2	1/2	21-FN8-10K	39.6	38.1	18.5	10000 (689)
1/2	1/4	21-FN8FN4-10K	44.4	38.1	11.4	10000 (689)

ISO 锥阴螺纹

P-RT 尺寸	Px-RT 尺寸	基本订购号	尺寸, mm			工作压力 psig (bar)
			L	F	E	
1/8	1/8	21-FR2	20.6	14.3	8.4	6500 (447)
1/4	1/4	21-FR4	30.2	19.1	11.2	6600 (454)
3/8	1/4	21-FR6FR4	35.1	22.2	11.2	5300 (365)
3/8	3/8	21-FR6	33.3	22.2	14.7	5300 (365)
1/2	1/4	21-FR8FR4	44.4	27.0	11.2	4900 (337)
1/2	3/8	21-FR8FR6	45.2	27.0	14.7	4900 (337)
1/2	1/2	21-FR8	39.6	27.0	18.3	4900 (337)

大阴小阳螺纹接头 (内外丝)

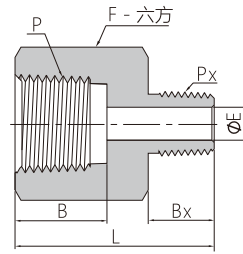

NPT 阴螺纹

P-NPT 尺寸	Px-NPT 尺寸	基本订购号	尺寸, mm					工作压力 psig (bar)
			L	F	B	Bx	E	316 不锈钢, 碳钢
1/8	1/16	21-FN2N1	27.7	14.3	10.4	9.7	3.0	6500 (447)
1/8	1/8	21-FN2N2	27.9	14.3	10.4	9.7	4.8	6500 (447)
1/4	1/16	21-FN4N1	30.5	19.1	15.0	9.7	3.0	6600 (454)
1/4	1/8	21-FN4N2	32.0	19.1	15.0	9.7	4.8	6600 (454)
1/4	1/4	21-FN4N4	35.6	19.1	15.0	14.2	7.1	6600 (454)
3/8	1/16	21-FN6N1	31.8	22.2	15.0	9.7	3.0	5300 (365)
3/8	1/8	21-FN6N2	33.8	22.2	15.0	9.7	4.8	5300 (365)
3/8	1/4	21-FN6N4	38.1	22.2	15.0	14.2	7.1	5300 (365)
3/8	3/8	21-FN6N6	38.4	22.2	15.0	14.2	9.7	5300 (365)
1/2	1/8	21-FN8N2	40.1	27.0	19.8	9.7	4.8	4900 (337)
1/2	1/4	21-FN8N4	44.7	27.0	19.8	14.2	7.1	4900 (337)
1/2	3/8	21-FN8N6	44.4	27.0	19.8	14.2	9.6	4900 (337)
1/2	1/2	21-FN8N8	49.3	27.0	19.8	19.1	11.9	4900 (337)
3/4	1/8	21-FN12N2	39.6	33.3	20.6	9.7	4.8	4600 (316)
3/4	1/4	21-FN12N4	47.0	33.3	20.6	14.2	7.1	4600 (316)
3/4	3/8	21-FN12N6	46.2	33.3	20.6	14.2	9.7	4600 (316)
3/4	1/2	21-FN12N8	51.3	33.3	20.6	19.1	11.9	4600 (316)
3/4	3/4	21-FN12N12	51.3	33.3	20.6	19.1	15.7	4600 (316)
1	1/8	21-FN16N2	46.0	41.3	25.4	9.7	4.8	4400 (303)
1	1/4	21-FN16N4	49.8	41.3	25.4	14.2	7.1	4400 (303)
1	3/8	21-FN16N6	50.8	41.3	25.4	14.2	9.7	4400 (303)
1	1/2	21-FN16N8	54.9	41.3	25.4	19.1	11.9	4400 (303)
1	3/4	21-FN16N12	55.1	41.3	25.4	19.1	15.7	4400 (303)
1	1	21-FN16N16	57.9	41.3	25.4	23.9	22.4	4400 (303)
1-1/4	1	21-FN20N16	62.7	54.0	25.4	23.9	22.4	4400 (303)

厚壁NPT阴螺纹转阳螺纹

1/4	1/4	21-FN4N4-10K	36.3	25.4	15.0	14.2	5.8	10000 (689)
1/2	1/2	21-FN8N8-10K	51.3	38.1	19.8	19.1	9.9	10000 (689)
1/2	1/2	21-FN8N4-10K	46.0	38.1	19.8	14.2	5.8	10000 (689)

NPT 阴螺纹

P-NPT 尺寸	Px-RT 尺寸	基本订购号	尺寸, mm					工作压力 psig (bar)
			L	F	B	Bx	E	316 不锈钢, 碳钢
1/8	1/8	21-FN2RT2	27.7	14.3	10.4	9.7	4.8	6500 (447)
1/4	1/4	21-FN4RT4	36.1	19.1	15.0	14.2	7.1	6600 (454)
3/8	3/8	21-FN6RT6	38.1	22.2	15.0	14.2	9.7	5300 (365)
1/2	1/2	21-FN8RT8	49.3	27.0	19.8	19.1	11.9	4900 (316)
3/4	3/4	21-FN12RT12	51.3	33.3	20.6	19.1	15.7	4600 (316)
1	1	21-FN16RT16	58.4	41.3	25.4	23.9	22.4	4400 (303)

ISO 锥阳螺纹

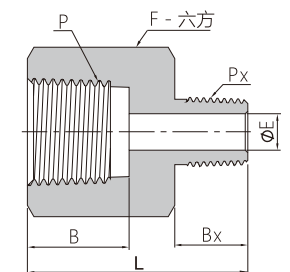
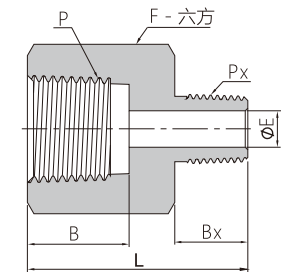
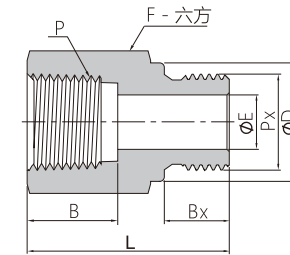
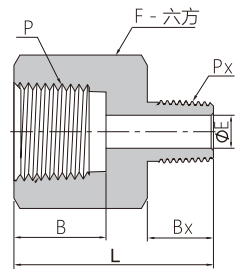

NPT 阴螺纹

P-NPT 尺寸	Px-RS 尺寸	基本订购号	尺寸, mm						工作压力 psig (bar)
			L	F	B	Bx	D	E	316 不锈钢, 碳钢
1/8	1/8	21-FN2BS2	25.1	14.3	9.9	7.1	13.7	4.1	6500 (447)
1/4	1/4	21-FN4BS4	33.5	19.1	10.4	11.2	18.0	5.8	6600 (454)
3/8	3/8	21-FN6BS6	35.8	22.2	15.0	11.2	21.6	7.9	5300 (365)
1/2	1/2	21-FN8BS8	44.2	27.0	15.0	14.2	25.9	11.9	4900 (316)
3/4	3/4	21-FN12BS12	48.0	33.3	20.6	15.7	32.0	15.7	4600 (316)
1	1	21-FN16BS16	53.3	41.3	25.4	18.3	38.9	19.8	4400 (303)

ISO 锥阳螺纹

ISO 锥阴螺纹

P-RT 尺寸	Px-RT 尺寸	基本订购号	尺寸, mm					工作压力 psig (bar)
			L	F	B	Bx	E	316 不锈钢, 碳钢
1/8	1/8	21-FR2R2	27.7	14.3	10.4	9.7	4.8	6500 (447)
1/4	1/8	21-FR4R2	32.0	19.1	15.0	9.7	4.8	6600 (454)
1/4	1/4	21-FR4R4	36.1	19.1	15.0	14.2	7.1	6600 (454)
3/8	1/4	21-FR6R4	38.1	22.2	15.0	14.2	7.1	5300 (365)
3/8	3/8	21-FR6R6	38.1	22.2	15.0	14.2	9.7	5300 (365)
1/2	1/4	21-FR8R4	44.7	27.0	19.8	14.2	7.1	4900 (337)
1/2	3/8	21-FR8R6	44.4	27.0	19.8	14.2	9.7	4900 (337)
1/2	1/2	21-FR8R8	49.5	27.0	19.8	19.1	11.2	4900 (337)
3/4	3/4	21-FR12R12	51.3	33.3	20.6	19.1	15.7	4600 (316)
1	1	21-FR16R16	58.4	41.3	25.4	23.9	22.4	4400 (303)

ISO 锥阳螺纹

ISO 锥阴螺纹

P-RT 尺寸	Px-NPT 尺寸	基本订购号	尺寸, mm					工作压力 psig (bar)
			L	F	B	Bx	E	316 不锈钢, 碳钢
1/8	1/8	21-FR2N2	27.7	14.3	10.4	9.7	4.8	6500 (447)
1/4	1/4	21-FR4N4	36.3	19.1	15.0	14.2	7.1	6600 (454)
3/8	3/8	21-FR6N6	38.4	22.2	15.0	14.2	9.6	5300 (365)
1/2	1/2	21-FR8N8	49.8	27.0	19.8	19.1	11.9	4900 (337)
3/4	3/4	21-FR12N12	51.3	33.3	20.6	19.1	15.7	4600 (316)
1	1	21-FR16N16	58.4	41.3	25.4	23.9	22.4	4400 (303)

NPT 阳螺纹

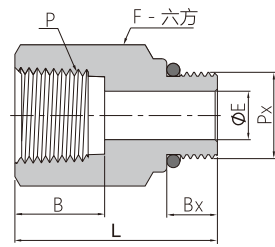

NPT 阴螺纹

P-NPT 尺寸	Px-SAE/MS 螺纹尺寸	基本订购号	尺寸, mm					SAE/MS 直阳螺纹	
			L	F	B	Bx	E	工作压力 psig (bar)	
1/4	7/16-20	21-FN4ST7	33.5	19.1	15.0	9.1	5.1	4500 (310)	
3/8	9/16-18	21-FN6ST9	35.3	23.8	15.0	9.9	7.1	4500 (310)	
1/2	3/4-16	21-FN8ST12	44.7	27.0	19.8	11.2	10.7	4500 (310)	
3/4	1-1/16-12	21-FN12ST17	50.5	34.9	20.6	15.0	16.7	3600 (248)	
1	1-5/16-12	21-FN16ST21	53.8	41.3	25.4	15.0	22.4	2900 (199)	

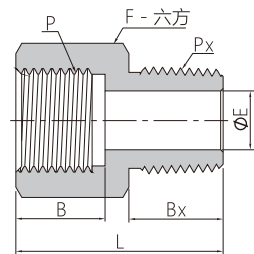

ISO 平行阴螺纹

P-RG 尺寸	Px-NPT 尺寸	基本订购号	尺寸, mm					NPT 阳螺纹	
			L	F	B	Bx	E	工作压力 psig (bar)	
1/8	1/8	21-FG2N2	21.8	14.3	6.5	9.7	4.8	6100 (420)	
1/4	1/4	21-FG4N4	30.2	19.1	12.9	14.2	5.6	5700 (392)	
3/8	3/8	21-FG6N6	32.2	23.8	14.2	14.2	6.6	5700 (392)	
1/2	1/2	21-FG8N8	42.7	27.0	18.8	19.1	7.1	3900 (268)	

阳螺纹弯通接头

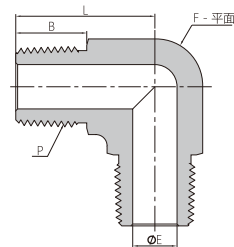

NPT 阳螺纹

P-NPT 尺寸	基本订购号	尺寸, mm				工作压力 psig (bar)	
		L	F	B	E	316 不锈钢, 碳钢	
1/16	22-N1	18.3	9.5	9.7	3.0	11000 (757)	
1/8	22-N2	22.4	11.1	9.7	4.8	10000 (689)	
1/4	22-N4	26.7	12.7	14.2	7.1	8000 (551)	
3/8	22-N6	29.7	17.5	14.2	9.6	7800 (537)	
1/2	22-N8	36.8	20.6	19.1	11.9	7700 (530)	
3/4	22-N12	40.4	27.0	19.1	15.7	7300 (502)	
1	22-N16	50.0	34.9	23.9	22.4	5300 (365)	

ISO 锥阳螺纹

P-RT 尺寸	基本订购号	尺寸, mm				工作压力 psig (bar)	
		L	F	B	E	316 不锈钢, 碳钢	
1/16	22-R1	18.3	9.5	9.7	3.0	11000 (757)	
1/8	22-R2	22.4	11.1	9.7	4.8	10000 (689)	
1/4	22-R4	26.7	12.7	14.2	7.1	8000 (551)	
3/8	22-R6	29.7	17.5	14.2	9.7	7800 (537)	
1/2	22-R8	36.8	20.6	19.1	11.9	7700 (530)	
3/4	22-R12	40.4	27.0	19.1	15.7	7300 (502)	
1	22-R16	50.0	34.9	23.9	22.4	5300 (365)	

阴阳螺纹弯通接头

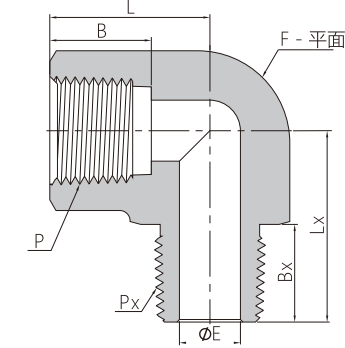

NPT 阴螺纹

P-NPT 尺寸	Px-NPT 尺寸	基本订购号	尺寸, mm						NPT 阳螺纹	
			L	F	B	E	Lx	Bx	工作压力 psig (bar)	
1/16	1/16	22-FN1N1	21.8	11.1	9.9	3.0	22.4	9.7	9200 (633)	
1/16	1/8	22-FN1N2	21.8	11.1	9.9	4.8	22.4	9.7	9200 (633)	
1/16	1/4	22-FN1N4	22.4	14.3	9.9	4.8	27.7	14.2	8000 (551)	
1/16	3/8	22-FN1N6	22.4	17.5	9.9	4.8	29.7	14.2	7800 (537)	
1/8	1/16	22-FN2N1	26.4	12.7	10.4	3.0	22.1	9.7	6200 (426)	
1/8	1/8	22-FN2N2	26.4	12.7	10.4	4.8	22.1	9.7	6200 (426)	
1/8	1/4	22-FN2N4	22.4	14.3	10.4	7.1	27.7	14.2	6500 (447)	
1/8	3/8	22-FN2N6	22.4	17.5	10.4	7.1	29.7	14.2	7800 (537)	
1/8	1/2	22-FN2N8	24.1	20.6	10.4	7.1	36.8	19.1	7700 (530)	
1/8	3/4	22-FN2N12	25.4	27.0	10.4	7.1	40.4	19.1	7300 (502)	
1/8	1	22-FN2N16	26.4	34.9	10.4	7.1	50.0	23.9	5300 (365)	
1/4	1/8	22-FN4N2	29.7	17.5	15.0	4.8	25.4	9.7	7200 (496)	
1/4	1/4	22-FN4N4	29.7	17.5	15.0	7.1	29.7	14.2	7200 (496)	
1/4	3/8	22-FN4N6	29.7	17.5	15.0	8.6	29.7	14.2	7200 (496)	
1/4	1/2	22-FN4N8	25.4	20.6	15.0	8.6	36.8	19.1	7200 (496)	
1/4	3/4	22-FN4N12	25.4	27.0	15.0	8.6	40.4	19.1	7300 (502)	
1/4	1	22-FN4N16	41.4	34.9	15.0	8.6	50.0	23.9	5300 (365)	
3/8	1/4	22-FN6N4	36.1	20.6	15.0	7.1	32.0	14.2	5600 (385)	
3/8	3/8	22-FN6N6	36.1	20.6	15.0	9.6	32.0	14.2	5600 (385)	
3/8	1/2	22-FN6N8	36.1	20.6	15.0	11.9	36.8	19.1	5600 (385)	
3/8	3/4	22-FN6N12	31.2	27.0	15.0	11.9	40.4	14.2	7300 (502)	
3/8	1	22-FN6N16	41.4	34.9	15.0	11.9	50.0	23.9	5300 (365)	
1/2	1/4	22-FN8N4	39.6	25.4	19.8	7.1	35.1	14.2	5600 (385)	
1/2	3/8	22-FN8N6	39.6	25.4	19.8	9.6	35.1	14.2	5600 (385)	
1/2	1/2	22-FN8N8	39.6	25.4	19.8	11.9	39.6	19.1	5600 (385)	
1/2	3/4	22-FN8N12	31.2	27.0	19.8	15.7	40.4	19.1	5600 (385)	
1/2	1	22-FN8N16	41.4	34.9	19.8	15.7	50.0	23.9	5300 (365)	
3/4	3/4	22-FN12N12	48.8	31.8	20.6	15.7	42.4	19.1	5100 (351)	
3/4	1	22-FN12N16	41.4	34.9	20.6	22.4	50.0	23.9	5100 (351)	
1	1	22-FM16N16	48.5	42.9	25.4	22.4	49.3	23.9	5300 (365)	
1-1/4	1-1/4	22-FN20N20	60.5	50.8	25.4	31.8	60.5	23.9	3100 (213)	

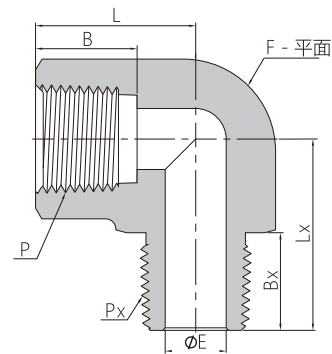

ISO 锥阴螺纹

ISO 锥阳螺纹

Px-RT 尺寸	Px-RT 尺寸	基本订购号	尺寸, mm						工作压力 psig (bar)	
			L	F	B	E	Lx	Bx	316 不锈钢, 碳钢	
1/16	1/16	22-FR1R1	21.8	11.1	9.9	3.0	22.4	9.7	9200 (633)	
1/16	1/8	22-FR1R2	21.8	11.1	9.9	4.8	22.4	9.7	9200 (633)	
1/16	1/4	22-FR1R4	22.4	14.3	9.9	4.8	27.7	14.2	8000 (551)	
1/16	3/8	22-FR1R6	22.4	17.5	9.9	4.8	29.7	14.2	7800 (537)	
1/8	1/16	22-FR2R1	26.4	12.7	10.4	3.0	22.1	9.7	6200 (426)	
1/8	1/8	22-FR2R2	26.4	12.7	10.4	4.8	22.1	9.7	6200 (426)	
1/8	1/4	22-FR2R4	22.4	14.3	10.4	7.1	27.7	14.2	6500 (447)	
1/8	3/8	22-FR2R6	22.4	17.5	10.4	7.1	29.7	14.2	7800 (537)	
1/8	1/2	22-FR2R8	24.1	20.6	10.4	7.1	36.8	19.1	7700 (530)	
1/8	3/4	22-FR2R12	25.4	27.0	10.4	7.1	40.4	19.1	7300 (502)	
1/8	1	22-FR2R16	26.4	34.9	10.4	7.1	50.0	23.9	5300 (365)	
1/4	1/8	22-FR4R2	29.7	17.5	15.0	4.8	25.4	9.7	7200 (496)	
1/4	1/4	22-FR4R4	29.7	17.5	15.0	7.1	29.7	14.2	7200 (496)	
1/4	3/8	22-FR4R6	29.7	17.5	15.0	8.6	29.7	14.2	7200 (496)	
1/4	1/2	22-FR4R8	25.4	20.6	15.0	8.6	36.8	19.1	7200 (496)	
1/4	3/4	22-FR4R12	25.4	27.0	15.0	8.6	40.4	19.1	7300 (502)	
1/4	1	22-FR4R16	41.4	34.9	15.0	8.6	50.0	23.9	5300 (365)	
3/8	1/4	22-FR6R4	36.1	20.6	15.0	7.1	32.0	14.2	5600 (385)	
3/8	3/8	22-FR6R6	36.1	20.6	15.0	9.7	32.0	14.2	5600 (385)	
3/8	1/2	22-FR6R8	36.1	20.6	15.0	11.9	36.8	19.1	5600 (385)	
3/8	3/4	22-FR6R12	31.2	27.0	15.0	11.9	40.4	19.1	7300 (502)	
3/8	1	22-FR6R16	41.4	34.9	15.0	11.9	50.0	23.9	5300 (365)	
1/2	1/4	22-FR8R4	39.6	25.4	19.8	7.1	35.1	14.2	5600 (385)	
1/2	3/8	22-FR8R6	39.6	25.4	19.8	9.7	35.1	14.2	5600 (385)	
1/2	1/2	22-FR8R8	39.6	25.4	19.8	11.9	39.6	19.1	5600 (385)	
1/2	3/4	22-FR8R12	31.2	27.0	19.8	15.7	40.4	19.1	5600 (385)	
1/2	1	22-FR8R16	41.4	34.9	19.8	15.7	50.0	23.9	5300 (365)	
3/4	3/4	22-FR12R12	48.8	31.8	20.6	15.7	42.4	19.1	5100 (351)	
3/4	1	22-FR12R16	41.4	34.9	20.6	22.4	50.0	23.9	5100 (351)	
1	1	22-FR16R16	48.5	42.9	25.4	22.4	49.3	23.9	5300 (365)	
1-1/4	1-1/4	22-FR20R20	60.5	50.8	25.4	31.8	60.5	23.9	3100 (213)	

45° 阴阳螺纹弯头

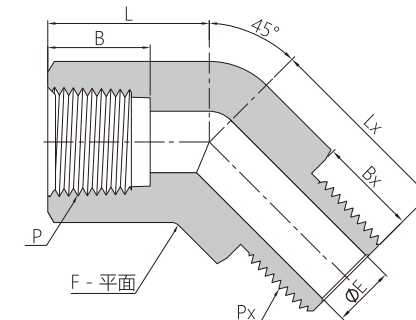

NPT 阴螺纹

NPT 阳螺纹

P-NPT 尺寸	Px-NPT 尺寸	基本订购号	尺寸, mm						工作压力 psig (bar)	
			L	F	B	E	Lx	Bx	316 不锈钢, 碳钢	
1/16	1/16	25-FN1N1	16.8	11.1	9.9	3.0	16.8	9.7	9200 (633)	
1/16	1/8	25-FN1N2	16.8	11.1	9.9	4.8	16.8	9.7	9200 (633)	
1/16	1/4	25-FN1N4	16.8	14.3	9.9	4.8	21.8	14.2	8000 (551)	
1/16	3/8	25-FN1N6	22.4	17.5	9.9	4.8	23.8	14.2	7800 (537)	
1/8	1/16	25-FN2N1	20.2	12.7	10.4	3.0	17.2	9.7	6200 (426)	
1/8	1/8	25-FN2N2	20.2	12.7	10.4	4.8	17.2	9.7	6200 (426)	
1/8	1/4	25-FN2N4	16.8	14.3	10.4	7.1	21.8	14.2	6500 (447)	
1/8	3/8	25-FN2N6	22.4	17.5	10.4	7.1	23.8	14.2	7800 (537)	
1/8	1/2	25-FN2N8	22.2	20.6	10.4	7.1	29.0	19.1	7700 (530)	
1/8	3/4	25-FN2N12	25.4	27.0	10.4	7.1	30.5	19.1	7300 (502)	
1/8	1	25-FN2N16	26.4	34.9	10.4	7.1	49.3	23.9	5300 (365)	
1/4	1/8	25-FN4N2	25.4	17.5	15.0	4.8	19.8	9.7	7200 (496)	
1/4	1/4	25-FN4N4	25.4	17.5	15.0	7.1	19.3	14.2	7200 (496)	
1/4	3/8	25-FN4N6	25.4	17.5	15.0	8.6	23.8	14.2	7200 (496)	
1/4	1/2	25-FN4N8	22.2	20.6	15.0	8.6	29.0	19.1	7200 (496)	
1/4	3/4	25-FN4N12	25.4	27.0	15.0	8.6	30.5	19.1	7300 (502)	
1/4	1	25-FN4N16	32.0	34.9	15.0	8.6	37.6	23.9	5300 (365)	
3/8	1/4	25-FN6N4	27.0	20.6	15.0	7.1	24.2	14.2	5600 (385)	
3/8	3/8	25-FN6N6	27.0	20.6	15.0	9.7	24.2	14.2	5600 (385)	
3/8	1/2	25-FN6N8	27.0	20.6	15.0	11.9	29.0	19.1	5600 (385)	
3/8	3/4	25-FN6N12	27.0	27.0	15.0	11.9	30.5	19.1	7300 (502)	
3/8	1	25-FN6N16	32.0	34.9	15.0	11.9	37.6	23.9	5300 (365)	
1/2	1/4	25-FN8N4	32.0	25.4	19.8	7.1	25.2	14.2	5600 (385)	
1/2	3/8	25-FN8N6	32.0	25.4	19.8	9.7	25.2	14.2	5600 (385)	
1/2	1/2	25-FN8N8	32.0	25.4	19.8	11.9	32.0	19.1	5600 (385)	
1/2	3/4	25-FN8N12	32.5	27.0	19.8	15.7	30.5	19.1	5600 (385)	
1/2	1	25-FN8N16	37.6	34.9	19.8	15.7	37.6	23.9	5300 (365)	
3/4	3/4	25-FN12N12	34.5	31.8	20.6	15.7	34.5	19.1	5100 (351)	
3/4	1	25-FN12N16	37.6	34.9	20.6	22.4	37.6	23.9	5100 (351)	
1	1	25-FN16N16	46.0	42.9	25.4	22.4	46.0	23.9	5300 (365)	
1-1/4	1-1/4	25-FN20N20	50.8	50.8	25.4	31.8	50.8	23.9	3100 (213)	

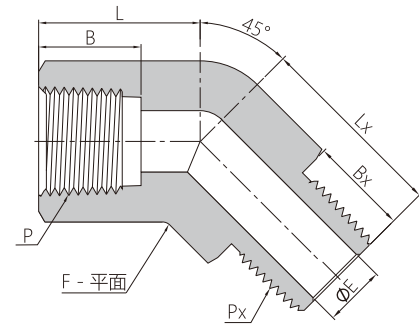

ISO 锥阴螺纹

ISO 锥阳螺纹

P-RT 尺寸	Px-RT 尺寸	基本订购号	尺寸, mm						工作压力 psig (bar)	
			L	F	B	E	Lx	Bx	316 不锈钢, 碳钢	
1/16	1/16	25-FR1R1	16.8	11.1	9.9	3.0	16.8	9.7	9200 (633)	
1/16	1/8	25-FR1R2	16.8	11.1	9.9	4.8	16.8	9.7	9200 (633)	
1/16	1/4	25-FR1R4	16.8	14.3	9.9	4.8	21.8	14.2	8000 (511)	
1/16	3/8	25-FR1R6	22.4	17.5	9.9	4.8	23.8	14.2	7800 (537)	
1/8	1/16	25-FR2R1	20.2	12.7	10.4	3.0	17.2	9.7	6200 (426)	
1/8	1/8	25-FR2R2	20.2	12.7	10.4	4.8	17.2	9.7	6200 (426)	
1/8	1/4	25-FR2R4	16.8	14.3	10.4	7.1	21.8	14.2	6500 (447)	
1/8	3/8	25-FR2R6	22.4	17.5	10.4	7.1	23.8	14.2	7800 (537)	
1/8	1/2	25-FR2R8	22.2	20.6	10.4	7.1	29.0	19.1	7700 (530)	
1/8	3/4	25-FR2R12	25.4	27.0	10.4	7.1	30.5	19.1	7300 (502)	
1/8	1	25-FR2R16	26.4	34.9	10.4	7.1	49.3	23.9	5300 (365)	
1/4	1/8	25-FR4R2	25.4	17.5	15.0	4.8	19.3	9.7	7200 (496)	
1/4	1/4	25-FR4R4	25.4	17.5	15.0	7.1	19.3	14.2	7200 (496)	
1/4	3/8	25-FR4R6	25.4	17.5	15.0	8.6	23.8	14.2	7200 (496)	
1/4	1/2	25-FR4R8	22.2	20.6	15.0	8.6	29.0	19.1	7200 (496)	
1/4	3/4	25-FR4R12	25.4	27.0	15.0	8.6	30.5	19.1	7300 (502)	
1/4	1	25-FR4R16	32.0	34.9	15.0	8.6	37.6	23.9	5300 (365)	
3/8	1/4	25-FR6R4	27.0	20.6	15.0	7.1	24.2	14.2	5600 (385)	
3/8	3/8	25-FR6R6	27.0	20.6	15.0	9.7	24.2	14.2	5600 (385)	
3/8	1/2	25-FR6R8	27.0	20.6	15.0	11.9	29.0	19.1	5600 (385)	
3/8	3/4	25-FR6R12	27.0	27.0	15.0	11.9	30.5	19.1	7300 (502)	
3/8	1	25-FR6R16	32.0	34.9	15.0	11.9	37.6	23.9	5300 (365)	
1/2	1/4	25-FR8R4	32.0	25.4	19.8	7.1	25.2	14.2	5600 (385)	
1/2	3/8	25-FR8R6	32.0	25.4	19.8	9.7	25.2	14.2	5600 (385)	
1/2	1/2	25-FR8R8	32.0	25.4	19.8	11.9	32.0	19.1	5600 (385)	
1/2	3/4	25-FR8R12	32.5	27.0	19.8	15.7	30.5	19.1	5600 (385)	
1/2	1	25-FR8R16	37.6	34.9	19.8	15.7	37.6	23.9	5300 (365)	
3/4	3/4	25-FR12R12	34.5	31.8	20.6	15.7	34.5	19.1	5100 (351)	
3/4	1	25-FR12R16	37.6	34.9	20.6	22.4	37.6	23.9	5100 (351)	
1	1	25-FR16R16	46.0	42.9	25.4	22.4	46.0	23.9	5300 (365)	
1-1/4	1-1/4	25-FR20R20	50.8	50.8	25.4	31.8	50.8	23.9	3100 (213)	

阴螺纹弯头

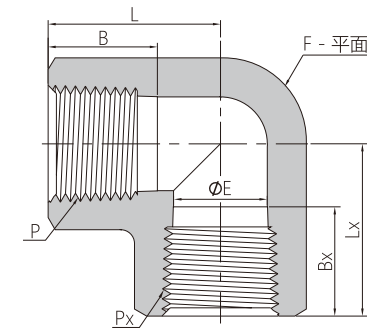

NPT 阴螺纹

P-NPT 尺寸	Px-NPT 尺寸	基本订购号	尺寸, mm						工作压力 psig (bar)	
			L	F	B	E	Lx	Bx	316 不锈钢, 碳钢	
1/16	1/16	22-FN1	21.8	11.1	9.9	4.8	21.8	9.9	6700 (460)	
1/8	1/16	22-FN2FN1	26.4	12.7	10.4	4.8	26.4	9.9	6200 (427)	
1/8	1/8	22-FN2	26.4	12.7	10.4	8.6	26.4	10.4	6200 (427)	
1/4	1/8	22-FN4FN2	29.7	17.5	15.0	7.1	29.7	10.4	7200 (496)	
1/4	1/4	22-FN4	29.7	17.5	15.0	11.4	29.7	15.0	7200 (496)	
3/8	3/8	22-FN6	36.1	20.6	15.0	15.0	36.1	15.0	5600 (385)	
1/2	1/2	22-FN8	39.6	25.4	19.8	18.5	39.6	19.8	5600 (385)	
3/4	3/4	22-FN12	48.8	31.8	20.6	23.9	48.8	20.6	5100 (351)	
1	1	22-FN16	48.5	42.9	25.4	29.7	48.5	25.4	6400 (440)	
1-1/4	1-1/4	22-FN20	59.8	50.8	25.4	27.7	50.8	25.4	3100 (213)	
1-1/2	1-1/2	22-FN24	65.0	63.5	27.7	34.0	52.8	27.7	5100 (351)	
厚壁NPT 阴螺纹										
1/4	1/4	22-FN4-10K	39.6	25.4	15.0	11.4	29.7	15.0	10000 (689)	
1/2	1/2	22-FN8-10K	50.0	42.9	19.8	18.5	39.6	19.8	10000 (689)	

ISO 锥阴螺纹

P-RT 尺寸	Px-RT 尺寸	基本订购号	尺寸, mm						工作压力 psig (bar)	
			L	F	B	E	Lx	Bx	316 不锈钢, 碳钢	
1/16	1/16	22-FR1	21.8	11.1	9.9	4.8	21.6	9.9	6700 (460)	
1/8	1/8	22-FR2FR1	16.8	12.7	10.4	4.8	16.8	9.9	6200 (427)	
1/8	1/8	22-FR2	26.4	12.7	10.4	7.1	26.4	10.4	6200 (427)	
1/4	1/4	22-FR4FR2	29.7	17.5	15.0	7.1	29.7	10.4	7200 (496)	
1/4	1/4	22-FR4	29.7	17.5	15.0	10.4	29.7	15.0	7200 (496)	
3/8	3/8	22-FR6	36.1	20.6	15.0	12.7	36.1	15.0	5600 (385)	
1/2	1/2	22-FR8	39.6	25.4	19.8	15.7	39.6	19.8	5600 (385)	
3/4	3/4	22-FR12	48.8	31.8	20.6	22.4	48.8	20.6	5100 (351)	
1	1	22-FR16	48.5	42.9	25.4	22.4	48.5	25.4	6400 (440)	
1-1/4	1-1/4	22-FR20	59.8	50.8	25.4	27.7	59.8	25.4	3100 (213)	
1-1/2	1-1/2	22-FR24	65.0	63.5	27.7	34.0	65.0	27.7	5100 (351)	

45°阴螺纹弯头

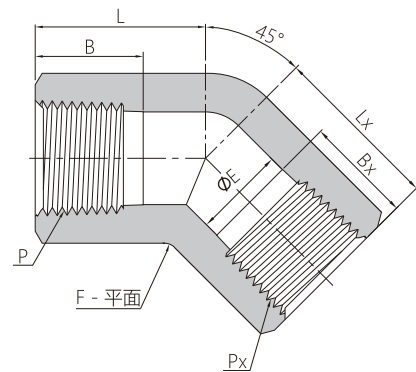

NPT 阴螺纹

P-NPT 尺寸	Px-NPT 尺寸	基本订购号	尺寸, mm						工作压力 psig (bar)	
			L	F	B	E	Lx	Bx	316 不锈钢, 碳钢	
1/16	1/16	25-FN1	16.8	11.1	9.9	4.8	16.8	9.9	6700 (460)	
1/8	1/16	25-FN2FN1	20.2	12.7	10.4	4.8	20.2	9.9	6200 (427)	
1/8	1/8	25-FN2	20.2	12.7	10.4	7.1	20.2	10.4	6200 (427)	
1/4	1/8	25-FN4FN2	25.4	17.5	15.0	7.1	25.4	10.4	7200 (496)	
1/4	1/4	25-FN4	25.4	17.5	15.0	10.4	25.4	15.0	7200 (496)	
3/8	3/8	25-FN6	27.0	20.6	15.0	12.7	27.0	15.0	5600 (385)	
1/2	1/2	25-FN8	32.0	25.4	19.8	15.7	32.0	19.8	5600 (385)	
3/4	3/4	25-FN12	34.5	31.8	20.6	22.4	34.5	20.6	5100 (351)	
1	1	25-FN16	46.0	42.9	25.4	22.4	46.0	25.4	6400 (440)	
1-1/4	1-1/4	25-FN20	43.2	50.8	25.4	27.7	43.2	25.4	3100 (213)	
1-1/2	1-1/2	25-FN24	46.0	63.5	27.7	34.0	46.0	27.7	5100 (351)	

ISO 锥阴螺纹

P-RT 尺寸	Px-RT 尺寸	基本订购号	尺寸, mm						工作压力 psig (bar)	
			L	F	B	E	Lx	Bx	316 不锈钢, 碳钢	
1/16	1/16	25-FR1	16.8	11.1	9.9	4.8	16.8	9.9	6700 (460)	
1/8	1/8	25-FR2FR1	20.2	12.7	10.4	4.8	20.2	9.9	6200 (427)	
1/8	1/8	25-FR2	20.2	12.7	10.4	7.1	20.2	10.4	6200 (427)	
1/4	1/4	25-FR4FR2	25.4	17.5	15.0	7.1	25.4	10.4	7200 (496)	
1/4	1/4	25-FR4	25.4	17.5	15.0	10.4	25.4	15.0	7200 (496)	
3/8	3/8	25-FR6	27.0	20.6	15.0	12.7	27.0	15.0	5600 (385)	
1/2	1/2	25-FR8	32.0	25.4	19.8	15.7	32.0	19.8	5600 (385)	
3/4	3/4	25-FR12	34.5	31.8	20.6	22.4	34.5	20.6	5100 (351)	
1	1	25-FR16	46.0	42.9	25.4	22.4	46.0	25.4	6400 (440)	
1-1/4	1-1/4	25-FR20	43.2	50.8	25.4	27.7	43.2	25.4	3100 (213)	
1-1/2	1-1/2	25-FR24	46.0	63.5	27.7	34.0	46.0	27.7	5100 (351)	

阳螺纹三通

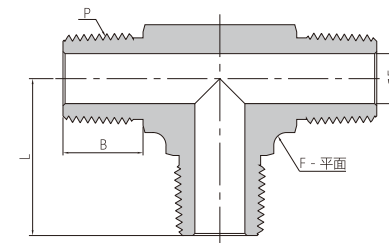

NPT 阳螺纹

P-NPT 尺寸	基本订购号	尺寸, mm				工作压力 psig (bar)	
		L	F	B	E	316 不锈钢, 碳钢	
1/16	23-N1	18.3	9.5	9.7	3.0	11000 (757)	
1/8	23-N2	22.4	11.1	9.7	4.8	10000 (689)	
1/4	23-N4	26.7	12.7	14.2	7.1	8000 (551)	
3/8	23-N6	29.7	17.5	14.2	9.6	7800 (537)	
1/2	23-N8	36.8	20.6	19.1	11.9	7700 (530)	
3/4	23-N12	42.4	27.0	19.1	15.7	7300 (502)	
1	23-N16	49.3	34.9	23.9	22.4	5300 (365)	
1-1/4	23-N20	56.4	42.9	23.9	27.7	6000 (410)	
1-1/2	23-N24	67.1	47.6	26.2	34.0	5000 (344)	

ISO 锥阴螺纹

P-RT 尺寸	基本订购号	尺寸, mm				工作压力 psig (bar)	
		L	F	B	E	316 不锈钢, 碳钢	
1/16	23-R1	18.3	9.5	9.7	3.0	11000 (757)	
1/8	23-R2	22.4	11.1	9.7	4.8	10000 (689)	
1/4	23-R4	26.7	12.7	14.2	7.1	8000 (551)	
3/8	23-R6	29.7	17.5	14.2	9.6	7800 (537)	
1/2	23-R8	36.8	20.6	19.1	11.9	7700 (530)	
3/4	23-R12	42.4	27.0	19.1	15.7	7300 (502)	
1	23-R16	49.3	34.9	23.9	22.4	5300 (365)	
1-1/4	23-R20	56.4	42.9	23.9	27.7	6000 (410)	
1-1/2	23-R24	67.1	47.6	26.2	34.0	5000 (344)	

支管阴螺纹三通

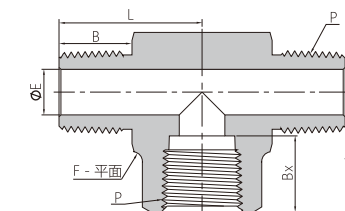

NPT 螺纹

P-NPT 尺寸	基本订购号	尺寸, mm						工作压力 psig (bar)	
		L	F	E	B	Lx	Bx	316 不锈钢, 碳钢	
1/16	23-N1N1FN1	18.3	11.1	3.0	9.7	21.8	9.9	9200 (633)	
1/8	23-N2N2FN2	22.1	12.7	4.8	9.7	26.4	10.4	6200 (427)	
1/4	23-N4N4FN4	29.7	17.5	7.1	14.2	29.7	15.0	7200 (496)	
3/8	23-N6N6FN6	32.0	20.6	9.7	14.2	36.1	15.0	5600 (385)	
1/2	23-N8N8FN8	39.6	25.4	11.9	19.1	39.6	19.8	5600 (385)	
3/4	23-N12N12FN12	42.4	31.8	15.7	19.1	48.8	20.6	5100 (351)	
1	23-N16N16FN16	49.3	42.9	22.4	23.9	48.5	25.4	5300 (365)	

ISO 锥螺纹

P-RT 尺寸	基本订购号	尺寸, mm						工作压力 psig (bar)	
		L	F	E	B	Lx	Bx	316 不锈钢, 碳钢	
1/16	23-R1R1FR1	18.3	11.1	3.0	9.7	21.8	9.9	9200 (633)	
1/8	23-R2R2FR2	22.1	12.7	4.8	9.7	26.4	10.4	6200 (427)	
1/4	23-R4R4FR4	29.7	17.5	7.1	14.2	29.7	15.0	7200 (496)	
3/8	23-R6R6FR6	32.0	20.6	9.7	14.2	36.1	15.0	5600 (385)	
1/2	23-R8R8FR8	39.6	25.4	11.9	19.1	39.6	19.8	5600 (385)	
3/4	23-R12R12FR12	42.4	31.8	15.7	19.1	48.8	20.6	5100 (351)	
1	23-R16R16FR16	49.3	42.9	22.4	23.9	48.5	25.4	5300 (365)	

支管阳螺纹三通

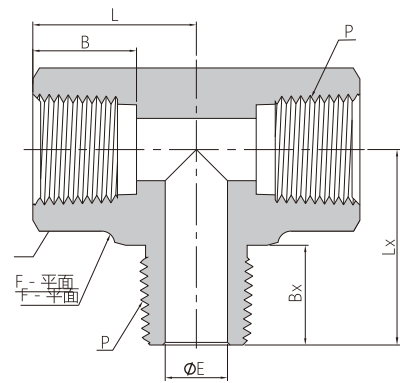

NPT 螺纹

P-NPT 尺寸	基本订购号	尺寸, mm						工作压力 psig (bar)
		L	F	E	B	Lx	Bx	316 不锈钢, 碳钢
1/16	23-FN1FN1N1	21.8	11.1	3.0	9.9	18.3	9.7	9200 (633)
1/8	23-FN2FN2N2	26.4	12.7	4.8	10.4	22.1	9.7	6200 (427)
1/4	23-FN4FN4N4	29.7	17.5	7.1	15.0	29.7	14.2	7200 (496)
3/8	23-FN6FN6N6	36.1	20.6	9.7	15.0	32.0	14.2	5600 (385)
1/2	23-FN8FN8N8	39.6	25.4	11.9	19.8	39.6	19.1	5600 (385)
3/4	23-FN12FN12N12	48.8	31.8	15.7	20.6	42.4	19.1	5100 (351)
1	23-FN16FN16N16	48.5	42.9	22.4	25.4	49.3	23.9	5300 (365)

ISO 锥螺纹

P-RT 尺寸	基本订购号	尺寸, mm						工作压力 psig (bar)
		L	F	E	B	Lx	Bx	316 不锈钢, 碳钢
1/16	23-FR1FR1R1	21.8	11.1	3.0	9.9	18.3	9.7	9200 (633)
1/8	23-FR2FR2R2	26.4	12.7	4.8	10.4	22.1	9.7	6200 (427)
1/4	23-FR4FR4R4	29.7	17.5	7.1	15.0	29.7	14.2	7200 (496)
3/8	23-FR6FR6R6	36.1	20.6	9.7	15.0	32.0	14.2	5600 (385)
1/2	23-FR8FR8R8	39.6	25.4	11.9	19.8	39.6	19.1	5600 (385)
3/4	23-FR12FR12R12	48.8	31.8	15.7	20.6	42.4	19.1	5100 (351)
1	23-FR16FR16R16	48.5	42.9	22.4	25.4	49.3	23.9	5300 (365)

主管阳螺纹三通

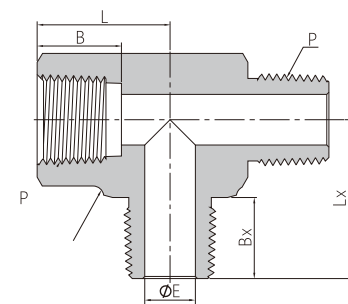

NPT 螺纹

P-NPT 尺寸	基本订购号	尺寸, mm						工作压力 psig (bar)
		L	F	E	B	Lx	Bx	316 不锈钢, 碳钢
1/16	23-FN1N1N1	21.8	11.1	3.0	9.9	18.3	9.7	9200 (633)
1/8	23-FN2N2N2	26.4	12.7	4.8	10.4	22.1	9.7	6200 (427)
1/4	23-FN4N4N4	29.7	17.5	7.1	15.0	29.7	14.2	7200 (496)
3/8	23-FN6N6N6	36.1	20.6	9.7	15.0	32.0	14.2	5600 (385)
1/2	23-FN8N8N8	39.6	25.4	11.9	19.8	39.6	19.1	5600 (385)
3/4	23-FN12N12N12	48.8	31.8	15.7	20.6	42.4	19.1	5100 (351)
1	23-FN16N16N16	48.5	42.9	22.4	25.4	49.3	23.9	5300 (365)

ISO 锥螺纹

P-RT 尺寸	基本订购号	尺寸, mm						工作压力 psig (bar)
		L	F	E	B	Lx	Bx	316 不锈钢, 碳钢
1/16	23-FR1R1R1	21.8	11.1	3.0	9.9	18.3	9.7	9200 (633)
1/8	23-FR2R2R2	26.4	12.7	4.8	10.4	22.1	9.7	6200 (427)
1/4	23-FR4R4R4	29.7	17.5	7.1	15.0	29.7	14.2	7200 (496)
3/8	23-FR6R6R6	36.1	20.6	9.7	15.0	32.0	14.2	5600 (385)
1/2	23-FR8R8R8	39.6	25.4	11.9	19.8	39.6	19.1	5600 (385)
3/4	23-FR12R12R12	48.8	31.8	15.7	20.6	42.4	19.1	5100 (351)
1	23-FR16R16R16	48.5	42.9	22.4	25.4	49.3	23.9	5300 (365)

主管阴螺纹三通

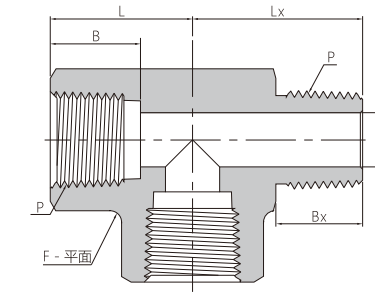

NPT 螺纹

P-NPT 尺寸	基本订购号	尺寸, mm						工作压力 psig (bar)
		L	F	E	B	Lx	Bx	316 不锈钢, 碳钢
1/16	23-FN1N1FN1	21.8	11.1	3.0	9.9	18.3	9.7	9200 (633)
1/8	23-FN2N2FN2	26.4	12.7	4.8	10.4	22.1	9.7	6200 (427)
1/4	23-FN4N4FN4	29.7	17.5	7.1	15.0	29.7	14.2	7200 (496)
3/8	23-FN6N6FN6	36.1	20.6	9.7	15.0	32.0	14.2	5600 (385)
1/2	23-FN8N8FN8	39.6	25.4	11.9	19.8	39.6	19.1	5600 (385)
3/4	23-FN12N12FN12	48.8	31.8	15.7	20.6	42.4	19.1	5100 (351)
1	23-FN16N16FN16	48.5	42.9	22.4	25.4	49.3	23.9	5300 (365)

NPT 螺纹

P-NPT 尺寸	基本订购号	尺寸, mm						工作压力 psig (bar)
		L	F	E	B	Lx	Bx	316 不锈钢, 碳钢
1/16	23-FR1R1FR1	21.8	11.1	3.0	9.9	18.3	9.7	9200 (633)
1/8	23-FR2R2FR2	26.4	12.7	4.8	10.4	22.1	9.7	6200 (427)
1/4	23-FR4R4FR4	29.7	17.5	7.1	15.0	29.7	14.2	7200 (496)
3/8	23-FR6R6FR6	36.1	20.6	9.7	15.0	32.0	14.2	5600 (385)
1/2	23-FR8R8FR8	39.6	25.4	11.9	19.8	39.6	19.1	5600 (385)
3/4	23-FR12R12FR12	48.8	31.8	15.7	20.6	42.4	19.1	5100 (351)
1	23-FR16R16FR16	48.5	42.9	22.4	25.4	49.3	23.9	5300 (365)

阴螺纹三通

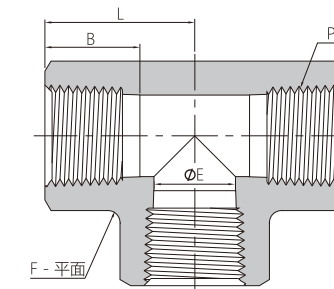

NPT 阴螺纹

P-NPT 尺寸	基本订购号	尺寸, mm				工作压力 psig (bar)
		L	F	E	B	316 不锈钢, 碳钢
1/16	23-FN1	21.8	11.1	4.8	9.9	6700 (460)
1/8	23-FN2	26.4	12.7	8.6	10.4	6200 (427)
1/4	23-FN4	29.7	17.5	11.4	15.0	7200 (496)
3/8	23-FN6	36.1	20.6	15.0	15.0	5600 (385)
1/2	23-FN8	39.6	25.4	18.5	19.8	5600 (385)
3/4	23-FN12	48.8	31.8	23.9	20.6	5100 (351)
1	23-FN16	48.5	42.9	29.7	25.4	6400 (440)
1-1/4	23-FN20	59.8	50.8	37.2	25.4	3100 (213)
1-1/2	23-FN24	65.0	63.5	43.3	27.7	5100 (351)

厚壁 NPT 阴螺纹

1/4	23-FN4-10K	39.6	25.4	11.4	15.0	10000 (689)
1/2	23-FN8-10K	50.0	27.0	18.5	19.8	10000 (689)

ISO 锥阴螺纹

P-RT 尺寸	基本订购号	尺寸, mm				工作压力 psig (bar)
		L	F	E	B	316 不锈钢, 碳钢
1/16	23-FR1	21.8	11.1	4.8	9.9	6700 (460)
1/8	23-FR2	26.4	12.7	8.6	10.4	6200 (427)
1/4	23-FR4	29.7	17.5	11.2	15.0	7200 (496)
3/8	23-FR6	36.1	20.6	14.7	15.0	5600 (385)
1/2	23-FR8	39.6	25.4	18.3	19.8	5600 (385)
3/4	23-FR12	48.8	31.8	23.9	20.6	5100 (351)
1	23-FR16	48.5	42.9	29.7	25.4	6400 (440)
1-1/4	23-FR20	59.8	50.8	37.2	25.4	3100 (213)
1-1/2	23-FR24	65.0	63.5	43.3	27.7	5100 (351)

阴螺纹四通

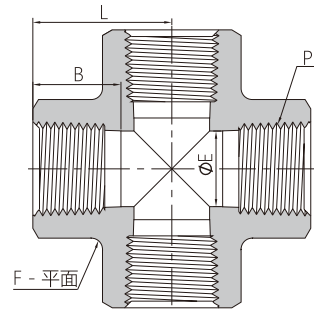

NPT 阴螺纹

P-NPT 尺寸	基本订购号	尺寸, mm				工作压力 psig (bar)
		L	F	E	B	316 不锈钢, 碳钢
1/16	24-FN1	21.8	11.1	4.8	9.9	6700 (460)
1/8	24-FN2	26.4	12.7	8.6	10.4	6200 (427)
1/4	24-FN4	29.7	17.5	11.4	15.0	7200 (496)
3/8	24-FN6	36.1	20.6	15.0	15.0	5600 (385)
1/2	24-FN8	39.6	25.4	18.5	19.8	5600 (385)
3/4	24-FN12	48.8	31.8	23.9	20.6	5100 (351)
1	24-FN16	48.5	42.9	29.7	25.4	6400 (440)

ISO 锥阴螺纹

P-RT 尺寸	基本订购号	尺寸, mm				工作压力 psig (bar)
		L	F	E	B	316 不锈钢, 碳钢
1/16	24-FR1	21.8	11.1	4.8	9.9	6700 (460)
1/8	24-FR2	26.4	12.7	8.6	10.4	6200 (427)
1/4	24-FR4	29.7	17.5	11.2	15.0	7200 (496)
3/8	24-FR6	36.1	20.6	14.7	15.0	5600 (385)
1/2	24-FR8	39.6	25.4	18.3	19.8	5600 (385)
3/4	24-FR12	48.8	31.8	23.9	20.6	5100 (351)
1	24-FR16	48.5	42.9	29.7	25.4	6400 (440)

阴阳螺纹活接头

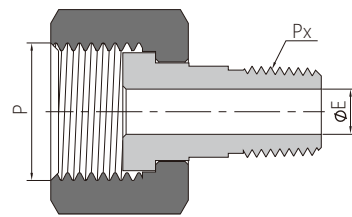

公制螺纹

P-公制螺纹 尺寸	Px-NPT 尺寸	基本订购号	尺寸, mm	工作压力 psig (bar)
			E	316 不锈钢, 碳钢
M20 x 1.5	1/8	21-FM20UN2	4.8	4500 (310)
M20 x 1.5	1/4	21-FM20UN4	7.1	4500 (310)

公制螺纹

P-公制螺纹 尺寸	Px-RT 尺寸	基本订购号	尺寸, mm	工作压力 psig (bar)
			E	316 不锈钢, 碳钢
M20 x 1.5	1/8	21-FM20UR2	4.8	4500 (310)
M20 x 1.5	1/4	21-FM20UR4	7.1	4500 (310)

ISO 平行螺纹

NPT 螺纹

P-ISO螺纹 尺寸	Px-NPT 尺寸	基本订购号	尺寸, mm	工作压力 psig (bar)
			E	316 不锈钢, 碳钢
1/2	1/8	PUP-BP8UN2	4.8	4900 (337)
1/2	1/4	PUP-BP8UN4	7.1	4900 (337)