



Test Report

(Valve fugitive emission test according to ISO15848-1: 2015+Amd.1:2017)

Certificate No. : 275572
Test Report No.: 275571

Applicant / Manufacturer: Jiangsu Xinzhongxin Co., Ltd.

Inspection body: TÜV SÜD Industrie Service GmbH
Floor 3-13, No.151, Heng Tong Road, Shanghai, P. R. China

Lab of test: Wenzhou Haichuan Inspection Co., Ltd.

Test Date: Feb. 01~Feb. 05, 2021

Description of valves: 1/2"-6000PSI 42 Series Pneumatic Ball Valve

Size: 1/2"

Pressure Rating: 6000PSI

Drawing No.: SS42-FX8FN8-P10-Q

Test Witnessed By: Wang Zhongxiang / TÜV SÜD Inspector

Inspection and Tests

1. Conformity of Equipment

The test equipment was verified by TÜV SÜD inspector according to requirements of ISO15848-1:2015+Amd.1:2017 and found satisfactory. The detailed arrangement of the fugitive emission test equipment is shown below:

Figure 1 Typical stem seal leakage measurement system with Bagging Method

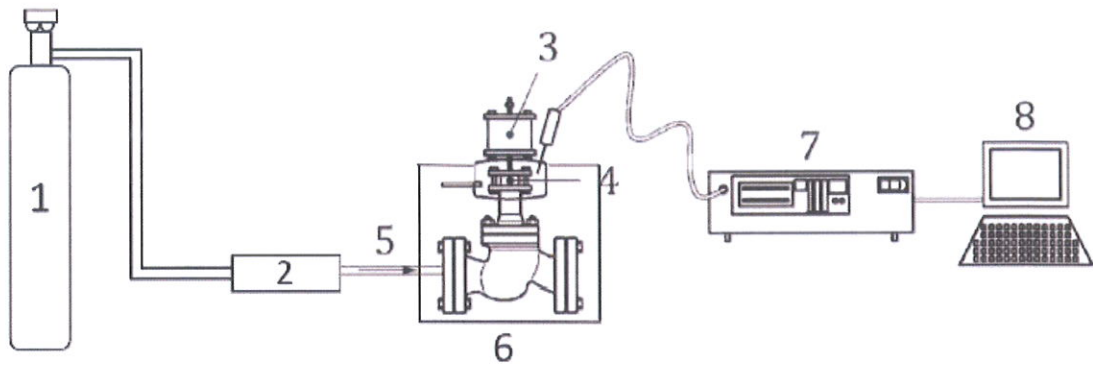

Key:

- | | | | |
|---|----------------------------------|---|-----------------------------------|
| 1 | 99%浓度氦气
Helium at 99% Purity | 5 | 氦气
Helium |
| 2 | 压力控制装置
Pressure Control | 6 | 加热装置
Heating Device |
| 3 | 执行器
Actuator | 7 | 氦气质谱仪
Helium Mass Spectrometer |
| 4 | 密封容器或者口袋
Sealed Volume or Bag | 8 | 数据采集
Date Acquisition |

Test Report No.: 275571

Figure 2 Typical body seal leakage measurement system with Sniffing Method

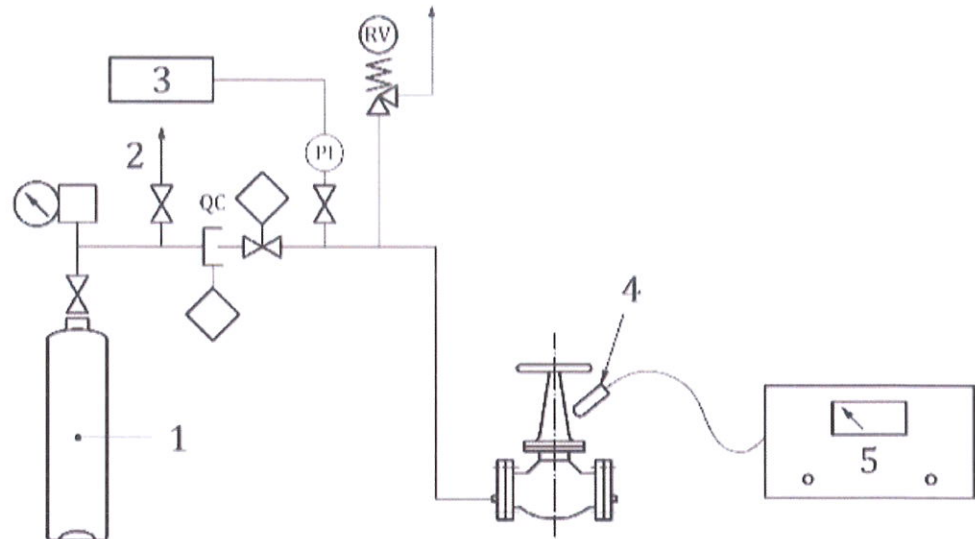

Key

- | | |
|---------------------|---------------------|
| 1 helium gas supply | 5 mass spectrometer |
| 2 vent | QC quick coupling |
| 3 pressure recorder | RV relief valve |
| 4 probe | PI pressure sensor |

2. Document review

The specific product data file provided by the valve manufacturer includes:

- cross sectional valve assembly drawing;
- bill of valve material
- stem or shaft seal description, dimension and specifications;
- body seal description, dimension and specifications;
- material specifications of stem or shaft seal components;
- hydrostatic test certificate.

The above documents are reviewed with no objection.

Test Report No.: 275571

3. Technical Data of Test Valve:

a) General description of test valve

Name of manufacturer	Jiangsu Xinzhongxin Co., Ltd.
Address of manufacturer	No. 18 Danyan Rd., Fenghuang Industrial Park, Danyang City, Jiangsu Province, P.R. China
Item	1/2"-6000PSI 42 Series Pneumatic Ball Valve
Valve size	1/2"
Pressure rating	6000PSI
Stem size	Φ12mm
Body/bonnet material	316SS
Seal material	PTFE
Valve assembly drawing no.	SS42-FX8FN8-P10-Q

4. Visual and dimensional check of the test valve:

The test valve was chosen at random by the manufacturer in its workshop and submitted to the laboratory. The visual and dimensional check was performed according to drawing No.: SS42-FX8FN8-P10-Q and results found satisfactory. The mark was verified on valve as following:

	<u>1/2"</u>	<u>6000PSI</u>	<u>316SS</u>
Manufacturer' Brand	Size	Class	Material

The stem size was measured as Ø12mm.

5. Preparation of the test valve:

Before the fugitive emission test, the test valve was hydrostatic tested under 62MPa, the test showed no visible leakage or deformation. Then the valve was cleaned and dried.

6. Calibration of test instrument

The test instrument was turned on, warmed up at the minimum time according to the requirements of the equipment manufacturer and calibrated with the standard calibrated leak 99% helium according to the procedure specified in Annex A, Para.A.1.4.2 of ISO15848-1:2015+Amd.1:2017.

7. Fugitive emission test and measurement

The test valve was mounted on a test rig with the stem positioned vertical. And the fugitive emission test is carried out as per requirement of ISO15848-1:2015+Amd.1:2017 Para.5.



Test Report No.: 275571

7.1 Preliminary tests at room temperature (test 1)

The valve was pressurized with test fluid Helium to 41.37MPa according to manufacturer's requirements in the partly opened position, the temperature at locations "X"/"Y"/"Z" are measure and recorded as room temperature.

The stem seal leakage measurement was performed by the Vacuum method as described in ISO15848-1 Annex A.

The body seal leakage measurement was performed by the sniffing method as described in ISO15848-1 Annex B.

The test results are as follows:

Test results of preliminary tests

Item	ISO15848-1 Required Value	Actual Value
Stem leakage (mbar.l/s)	$\leq 2.14 \times 10^{-5}$	2.58×10^{-7}
Body seal leakage(ppmv)	≤ 50	5.64

The test results meet the requirements of ISO15848-1:2015+Amd.1:2017.

7.2 Mechanical cycle test at the room temperature (test 2)

A total of 50 mechanical cycles was performed on the test valve while it was kept pressurized under a differential pressure of 41.37MPa according to the manufacturer's requirements at room temperature. The leakage from the stem seal was measured with following results:

Test results of final tests

Item	ISO15848-1 Required Value	Actual Value
Stem leakage (mbar.l/s)	$\leq 2.14 \times 10^{-5}$	3.69×10^{-7}

The test results meet the requirements of ISO15848-1:2015+Amd.1:2017.

7.3 Static test at the selected temperature (test 3)

The test valve was reduced till to -40°C. The test valve was kept pressure with 41.37MPa according to manufacturer's requirements. The leakage from the stem seal was measured with following results:

Test results of final tests

Item	ISO15848-1 Required Value	Actual Value
Stem leakage (mbar.l/s)	$\leq 2.14 \times 10^{-5}$	4.01×10^{-7}

The test results meet the requirements of ISO15848-1:2015+Amd.1:2017.

7.4 Mechanical cycle test at the selected temperature (test 4)

A total of 50 mechanical cycles was performed on the test valve while it was kept pressurized under a differential pressure of 41.37MPa according to the manufacturer's requirements at -40°C. The leakage from the stem seal was measured with following results:

Test results of final tests

Item	ISO15848-1 Required Value	Actual Value
Stem leakage (mbar.l/s)	$\leq 2.14 \times 10^{-5}$	4.45×10^{-7}

The test results meet the requirements of ISO15848-1:2015+Amd.1:2017.



Test Report No.: 275571

7.5 Repeat static test at the room temperature (test 5)

The test valve returned to the room temperature naturally, without artificial cooling/heating. After the temperature was stabilized at room temperature. Then the stem seal leakage under 41.37MPa according to manufacturer's requirements was measured using the same method as above and the test result was recorded as follow-

Test results of final tests

Item	ISO15848-1 Required Value	Actual Value
Stem leakage (mbar.l/s)	$\leq 2.14 \times 10^{-5}$	5.36×10^{-7}
The test results meet the requirements of ISO15848-1:2015+Amd.1:2017.		

7.6 Repeat mechanical cycle test at the room temperature (test 2)

A total of 50 mechanical cycles was performed on the test valve while it was kept pressurized under a differential pressure of 41.37MPa according to the manufacturer's requirements at room temperature. The leakage from the stem seal was measured with following results:

Test results of final tests

Item	ISO15848-1 Required Value	Actual Value
Stem leakage (mbar.l/s)	$\leq 2.14 \times 10^{-5}$	4.98×10^{-7}
The test results meet the requirements of ISO15848-1:2015+Amd.1:2017.		

7.7 Repeat static test at the selected temperature (test 3)

The test valve was reduced till to -40°C. The test valve was kept pressure with 41.37MPa according to manufacturer's requirements. The leakage from the stem seal was measured with following results:

Test results of final tests

Item	ISO15848-1 Required Value	Actual Value
Stem leakage (mbar.l/s)	$\leq 2.14 \times 10^{-5}$	6.99×10^{-7}
The test results meet the requirements of ISO15848-1:2015+Amd.1:2017.		

7.8 Repeat mechanical cycle test at the selected temperature (test 4)

A total of 50 mechanical cycles was performed on the test valve while it was kept pressurized under a differential pressure of 41.37MPa according to the manufacturer's requirements at -40°C. The leakage from the stem seal was measured with following results:

Test results of final tests

Item	ISO15848-1 Required Value	Actual Value
Stem leakage (mbar.l/s)	$\leq 2.14 \times 10^{-5}$	5.64×10^{-7}
The test results meet the requirements of ISO15848-1:2015+Amd.1:2017.		

7.9 Intermediate static test at room temperature (test 5)

The test valve returned to the room temperature naturally, without artificial cooling/heating. After the temperature was stabilized at room temperature. Then the stem seal leakage under 41.37MPa according to manufacturer's requirements was measured and the test result was recorded as follow-



Test Report No.: 275571

Test results of final tests

Item	ISO15848-1 Required Value	Actual Value
Stem leakage (mbar.l/s)	$\leq 2.14 \times 10^{-5}$	7.10×10^{-7}
The test results meet the requirements of ISO15848-1:2015+Amd.1:2017.		

7.10 Final test at room temperature (test 6)

The test valve returned to the room temperature naturally, without artificial cooling/heating. After the temperature was stabilized at room temperature. Then the stem seal leakage under 41.37MPa according to manufacturer's requirements was measured using the same method as mentioned in paragraph 7.1 after 5 mechanical cycles and the test result was recorded as follow-

Test results of final tests

Item	ISO15848-1 Required Value	Actual Value
Stem leakage (mbar.l/s)	$\leq 2.14 \times 10^{-5}$	8.00×10^{-7}
The test results meet the requirements of ISO15848-1:2015+Amd.1:2017.		

7.11 Repeat mechanical cycle test at the room temperature (test 2)

A total of 795 mechanical cycles was performed on the test valve while it was kept pressurized under a differential pressure of 41.37MPa according to the manufacturer's requirements at room temperature. The leakage from the stem seal was measured with following results:

Test results of final tests

Item	ISO15848-1 Required Value	Actual Value
Stem leakage (mbar.l/s)	$\leq 2.14 \times 10^{-5}$	8.87×10^{-7}
The test results meet the requirements of ISO15848-1:2015+Amd.1:2017.		

7.12 Repeat static test at the selected temperature (test 3)

The test valve was reduced till to -40°C. The test valve was kept pressure with 41.37MPa according to manufacturer's requirements. The leakage from the stem seal was measured with following results:

Test results of final tests

Item	ISO15848-1 Required Value	Actual Value
Stem leakage (mbar.l/s)	$\leq 2.14 \times 10^{-5}$	8.24×10^{-7}
The test results meet the requirements of ISO15848-1:2015+Amd.1:2017.		

7.13 Repeat mechanical cycle test at the selected temperature (test 4)

A total of 500 mechanical cycles was performed on the test valve while it was kept pressurized under a differential pressure of 41.37MPa according to the manufacturer's requirements at -40°C. The leakage from the stem seal was measured with following results:

Test results of final tests

Item	ISO15848-1 Required Value	Actual Value
Stem leakage (mbar.l/s)	$\leq 2.14 \times 10^{-5}$	9.24×10^{-7}
The test results meet the requirements of ISO15848-1:2015+Amd.1:2017.		

Test Report No.: 275571

7.14 Final test at room temperature (test 6)

The test valve returned to the room temperature naturally, without artificial cooling/heating. After the temperature was stabilized at room temperature. Then the stem seal leakage under 41.37MPa according to manufacturer's requirements was measured using the same method as mentioned in paragraph 7.1 and the test result was recorded as follow-

Test results of final tests

Item	ISO15848-1 Required Value	Actual Value
Stem leakage (mbar.l/s)	$\leq 2.14 \times 10^{-5}$	8.45×10^{-7}
The test results meet the requirements of ISO15848-1:2015+Amd.1:2017.		

7.15 Repeat mechanical cycle test at the room temperature (test 2)

A total of 500 mechanical cycles was performed on the test valve while it was kept pressurized under a differential pressure of 41.37MPa according to the manufacturer's requirements at room temperature. The leakage from the stem seal was measured with following results:

Test results of final tests

Item	ISO15848-1 Required Value	Actual Value
Stem leakage (mbar.l/s)	$\leq 2.14 \times 10^{-5}$	8.87×10^{-7}
The test results meet the requirements of ISO15848-1:2015+Amd.1:2017.		

7.16 Repeat static test at the selected temperature (test 3)

The test valve was reduced till to -40°C. The test valve was kept pressure with 41.37MPa according to manufacturer's requirements. The leakage from the stem seal was measured with following results:

Test results of final tests

Item	ISO15848-1 Required Value	Actual Value
Stem leakage (mbar.l/s)	$\leq 2.14 \times 10^{-5}$	1.05×10^{-6}
The test results meet the requirements of ISO15848-1:2015+Amd.1:2017.		

7.17 Repeat mechanical cycle test at the selected temperature (test 4)

A total of 500 mechanical cycles was performed on the test valve while it was kept pressurized under a differential pressure of 41.37MPa according to the manufacturer's requirements at -40°C. The leakage from the stem seal was measured with following results:

Test results of final tests

Item	ISO15848-1 Required Value	Actual Value
Stem leakage (mbar.l/s)	$\leq 2.14 \times 10^{-5}$	9.64×10^{-7}
The test results meet the requirements of ISO15848-1:2015+Amd.1:2017.		



Test Report No.: 275571

7.18 Final test at room temperature (test 6)

The test valve returned to the room temperature naturally, without artificial cooling/heating. After the temperature was stabilized at room temperature. Then the stem seal leakage under 41.37MPa according to manufacturer's requirements was measured using the same method as mentioned in paragraph 7.1 and the test result was recorded as follow-

Test results of final tests

Item	ISO15848-1 Required Value	Actual Value
Stem leakage (mbar.l/s)	$\leq 2.14 \times 10^{-5}$	8.62×10^{-7}
Body seal leakage(ppmv)	≤ 50	9.55

The test results meet the requirements of ISO15848-1:2015+Amd.1:2017.

7.19 Preliminary tests at room temperature (test 1)

The valve was pressurized with test fluid Helium to 41.37MPa according to manufacturer's requirements in the partly opened position, the temperature at locations "X"/"Y"/"Z" are measure and recorded as room temperature. The test results are as follows:

Test results of preliminary tests

Item	ISO15848-1 Required Value	Actual Value
Stem leakage (mbar.l/s)	$\leq 2.14 \times 10^{-5}$	9.33×10^{-7}
Body seal leakage(ppmv)	≤ 50	9.61

The test results meet the requirements of ISO15848-1:2015+Amd.1:2017.

7.20 Mechanical cycle test at the room temperature (test 2)

A total of 50 mechanical cycles was performed on the test valve while it was kept pressurized under a differential pressure of 41.37MPa according to the manufacturer's requirements at room temperature. The leakage from the stem seal was measured with following results:

Test results of final tests

Item	ISO15848-1 Required Value	Actual Value
Stem leakage (mbar.l/s)	$\leq 2.14 \times 10^{-5}$	9.96×10^{-7}

The test results meet the requirements of ISO15848-1:2015+Amd.1:2017.

7.21 Static test at the selected temperature (test 3)

The test valve was heated till to 232°C. The test valve was kept pressure with 28.50MPa according to manufacturer's requirements. The leakage from the stem seal was measured with following results:

Test results of final tests

Item	ISO15848-1 Required Value	Actual Value
Stem leakage (mbar.l/s)	$\leq 2.14 \times 10^{-5}$	1.58×10^{-6}

The test results meet the requirements of ISO15848-1:2015+Amd.1:2017.



Test Report No.: 275571

7.22 Mechanical cycle test at the selected temperature (test 4)

A total of 50 mechanical cycles was performed on the test valve while it was kept pressurized under a differential pressure of 28.50MPa according to the manufacturer's requirements at 232°C. The leakage from the stem seal was measured with following results:

Test results of final tests

Item	ISO15848-1 Required Value	Actual Value
Stem leakage (mbar.l/s)	$\leq 2.14 \times 10^{-5}$	2.07×10^{-6}
The test results meet the requirements of ISO15848-1:2015+Amd.1:2017.		

7.23 Repeat static test at the room temperature (test 5)

The test valve returned to the room temperature naturally, without artificial cooling/heating. After the temperature was stabilized at room temperature. Then the stem seal leakage under 41.37MPa according to manufacturer's requirements was measured using the same method as above and the test result was recorded as follow-

Test results of final tests

Item	ISO15848-1 Required Value	Actual Value
Stem leakage (mbar.l/s)	$\leq 2.14 \times 10^{-5}$	2.22×10^{-6}
The test results meet the requirements of ISO15848-1:2015+Amd.1:2017.		

7.24 Repeat mechanical cycle test at the room temperature (test 2)

A total of 50 mechanical cycles was performed on the test valve while it was kept pressurized under a differential pressure of 41.37MPa according to the manufacturer's requirements at room temperature. The leakage from the stem seal was measured with following results:

Test results of final tests

Item	ISO15848-1 Required Value	Actual Value
Stem leakage (mbar.l/s)	$\leq 2.14 \times 10^{-5}$	2.97×10^{-6}
The test results meet the requirements of ISO15848-1:2015+Amd.1:2017.		

7.25 Repeat static test at the selected temperature (test 3)

The test valve was heated till to 232°C. The test valve was kept pressure with 28.50MPa according to manufacturer's requirements. The leakage from the stem seal was measured with following results:

Test results of final tests

Item	ISO15848-1 Required Value	Actual Value
Stem leakage (mbar.l/s)	$\leq 2.14 \times 10^{-5}$	5.24×10^{-6}
The test results meet the requirements of ISO15848-1:2015+Amd.1:2017.		

7.26 Repeat mechanical cycle test at the selected temperature (test 4)

A total of 50 mechanical cycles was performed on the test valve while it was kept pressurized under a differential pressure of 28.50MPa according to the manufacturer's requirements at 232°C. The leakage from the stem seal was measured with following results:

Test Report No.: 275571

Test results of final tests

Item	ISO15848-1 Required Value	Actual Value
Stem leakage (mbar.l/s)	$\leq 2.14 \times 10^{-5}$	4.27×10^{-6}
The test results meet the requirements of ISO15848-1:2015+Amd.1:2017.		

7.27 Intermediate static test at room temperature (test 5)

The test valve returned to the room temperature naturally, without artificial cooling/heating. After the temperature was stabilized at room temperature. Then the stem seal leakage under 41.37MPa according to manufacturer's requirements was measured and the test result was recorded as follow-

Test results of final tests

Item	ISO15848-1 Required Value	Actual Value
Stem leakage (mbar.l/s)	$\leq 2.14 \times 10^{-5}$	3.69×10^{-6}
The test results meet the requirements of ISO15848-1:2015+Amd.1:2017.		

7.28 Final test at room temperature (test 6)

The test valve returned to the room temperature naturally, without artificial cooling/heating. After the temperature was stabilized at room temperature. Then the stem seal leakage under 41.37MPa according to manufacturer's requirements was measured using the same method as mentioned in paragraph 7.1 after 5 mechanical cycles and the test result was recorded as follow-

Test results of final tests

Item	ISO15848-1 Required Value	Actual Value
Stem leakage (mbar.l/s)	$\leq 2.14 \times 10^{-5}$	4.78×10^{-6}
Body seal leakage(ppmv)	≤ 50	24
The test results meet the requirements of ISO15848-1:2015+Amd.1:2017.		

7.29 Repeat mechanical cycle test at the room temperature (test 2)

A total of 795 mechanical cycles was performed on the test valve while it was kept pressurized under a differential pressure of 41.37MPa according to the manufacturer's requirements at room temperature. The leakage from the stem seal was measured with following results:

Test results of final tests

Item	ISO15848-1 Required Value	Actual Value
Stem leakage (mbar.l/s)	$\leq 2.14 \times 10^{-5}$	5.97×10^{-6}
The test results meet the requirements of ISO15848-1:2015+Amd.1:2017.		

7.30 Static test at the selected temperature (test 3)

The test valve was heated till to 232°C. The test valve was kept pressure with 28.50MPa according to manufacturer's requirements. The leakage from the stem seal was measured with following results:

Test results of final tests

Item	ISO15848-1 Required Value	Actual Value
Stem leakage (mbar.l/s)	$\leq 2.14 \times 10^{-5}$	5.55×10^{-6}
The test results meet the requirements of ISO15848-1:2015+Amd.1:2017.		



Test Report No.: 275571

7.31 Mechanical cycle test at the selected temperature (test 4)

A total of 500 mechanical cycles was performed on the test valve while it was kept pressurized under a differential pressure of 28.50MPa according to the manufacturer's requirements at 232°C. The leakage from the stem seal was measured with following results:

Test results of final tests

Item	ISO15848-1 Required Value	Actual Value
Stem leakage (mbar.l/s)	$\leq 2.14 \times 10^{-5}$	6.32×10^{-6}

The test results meet the requirements of ISO15848-1:2015+Amd.1:2017.

7.32 Repeat static test at room temperature (test 6)

The test valve returned to the room temperature naturally, without artificial cooling/heating. After the temperature was stabilized at room temperature. Then the stem seal leakage under 41.37MPa according to manufacturer's requirements was measured using the same method as mentioned in paragraph 7.1 and the test result was recorded as follow-

Test results of final tests

Item	ISO15848-1 Required Value	Actual Value
Stem leakage (mbar.l/s)	$\leq 2.14 \times 10^{-5}$	5.94×10^{-6}
Body seal leakage(ppmv)	≤ 50	20

The test results meet the requirements of ISO15848-1:2015+Amd.1:2017.

7.33 Repeat mechanical cycle test at the room temperature (test 2)

A total of 500 mechanical cycles was performed on the test valve while it was kept pressurized under a differential pressure of 41.37MPa according to the manufacturer's requirements at room temperature. The leakage from the stem seal was measured with following results:

Test results of final tests

Item	ISO15848-1 Required Value	Actual Value
Stem leakage (mbar.l/s)	$\leq 2.14 \times 10^{-5}$	6.24×10^{-6}

The test results meet the requirements of ISO15848-1:2015+Amd.1:2017.

7.34 Repeat static test at the selected temperature (test 3)

The test valve was heated till to 232°C. The test valve was kept pressure with 28.50MPa according to manufacturer's requirements. The leakage from the stem seal was measured with following results:

Test results of final tests

Item	ISO15848-1 Required Value	Actual Value
Stem leakage (mbar.l/s)	$\leq 2.14 \times 10^{-5}$	8.94×10^{-6}

The test results meet the requirements of ISO15848-1:2015+Amd.1:2017.

Test Report No.: 275571

7.35 Repeat mechanical cycle test at the selected temperature (test 4)

A total of 500 mechanical cycles was performed on the test valve while it was kept pressurized under a differential pressure of 28.50MPa according to the manufacturer's requirements at 232°C. The leakage from the stem seal was measured with following results:

Test results of final tests

Item	ISO15848-1 Required Value	Actual Value
Stem leakage (mbar.l/s)	$\leq 2.14 \times 10^{-5}$	9.78×10^{-6}

The test results meet the requirements of ISO15848-1:2015+Amd.1:2017.

7.36 Final test at room temperature (test 6)

The test valve returned to the room temperature naturally, without artificial cooling/heating. After the temperature was stabilized at room temperature. Then the stem seal leakage under 41.37MPa according to manufacturer's requirements was measured using the same method as mentioned in paragraph 7.1 and the test result was recorded as follow-

Test results of final tests

Item	ISO15848-1 Required Value	Actual Value
Stem leakage (mbar.l/s)	$\leq 2.14 \times 10^{-5}$	9.78×10^{-6}
Body seal leakage(ppmv)	≤ 50	16.4

The test results meet the requirements of ISO15848-1:2015+Amd.1:2017.

8. Post test examination

After all the above tests completed, the test valve was disassembled and all sealing components visually examined. It is found that no notable wear and any other significant observations.



9. Performance classes

As a result of the above tests, the test valve covered performance classes as follows:
ISO FE BH – CO3 –SSA 0 – t (-40°C to 232°C) – 6000PSI – ISO 15848-1

10. Extension of qualification to untested valves shall be according to ISO15848-1:2015+Amd.1:2017 paragraph 8.

We, hereby declare that I have checked test valve and witnessed the fugitive emission test on the tested valve according to ISO15848-1:2015+Amd.1:2017. The test results are as mentioned in this report.

TÜV SÜD Industrie Service GmbH



 Wang Zhongxiang

Date: Feb 8th, 2021

Annexes:

- 1) Copy of Drawing No.: SS42-FX8FN8-P10-Q
- 2) Test Report of Fugitive Emission Test No.: HCT2021VB08005