

# 600 class cooling tower

MARLEY® 

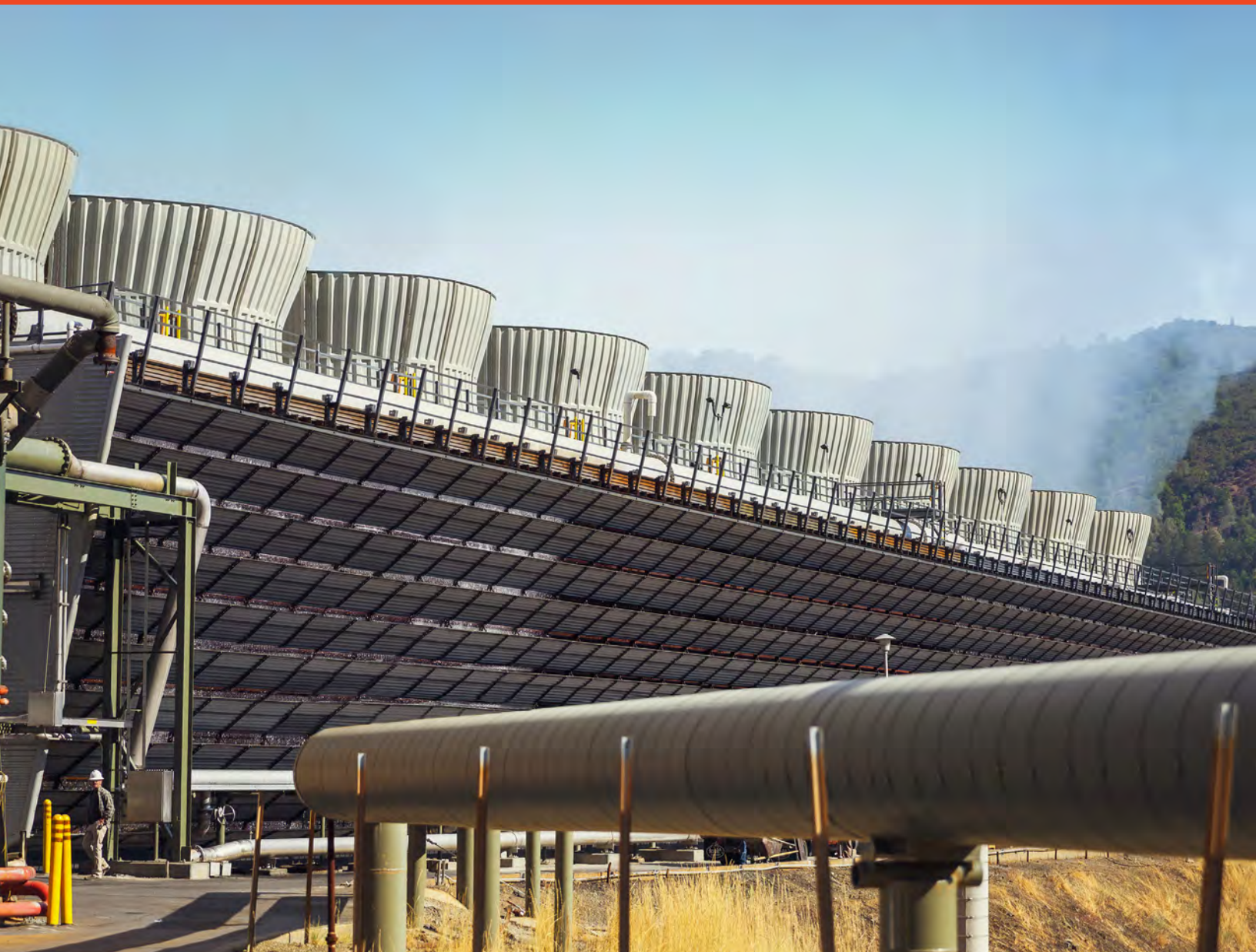





## **FLEXIBILITY OF DESIGN**

Marley 600 cooling towers are a direct descendent of the Doubleflow™ crossflow tower that was designed and patented by Marley in 1938. In 1957, Marley's development of hanging fill, wide indented louvers, and stable FRP velocity-recovery fan cylinders enabled the evolution of that Doubleflow tower into the classic Marley 600 shape and function that has set the standard for splash-fill crossflow towers for the past half-century.

In addition to form and function, the Marley 600 cooling tower has also established a high standard for ease of maintenance. The open accessibility and cleanability of its key components—fill, drift eliminators, water distribution system, and mechanical equipment—takes the drudgery out of maintenance.

After 60 plus years of industrial market leadership, the Marley 600 continues to be the tower of choice for users who know the value of thermal performance, dependability, operational reliability, structural integrity, and a host of other benefits that have become synonymous with the Marley brand.

Marley 600 cooling towers are available in various cell sizes, fill air travels, and fill heights. Within each of these cell plans, several aspects of the basic design can be varied in order to achieve optimum operating economy. The choices include variations in fill type and density, fan type and size, fan cylinder height and shape, drift eliminator type and density and water distribution method and operating head.

For each basic cell size, the designer can choose from a significant number of possible component combinations. Several of these may result in economical selections capable of the thermal performance requirements, but only one will optimally satisfy the fan horsepower, pump head, plan area, and other evaluation parameters that may have been imposed by the owner's specifications.

Our design engineers review each cooling tower application to assure that the components selected will work together as efficiently as possible. Computer optimization assures maximum cooling from a given tower cell size for each set of design performance conditions.

## MECHANICAL EQUIPMENT



### Fan

Marley designed and manufactured fans are used on all Marley crossflow towers. The fan selection and fan speed for a given tower are based on tower cell size, system losses, and horsepower requirements. Depending on fan size, blade material is FRP (fiber reinforced polyester), GRE (glass reinforced epoxy), or cast aluminum alloy. Above 20'-0" diameter, Marley's HP7000 hollow core fan with erosion-resistant leading edge is standard. Large fan hubs are heavy-duty steel plate and ductile cast iron components, hot dip galvanized after fabrication. Smaller fan hubs are either epoxy-coated cast iron or heat-treated aircraft aluminum alloy plate. All fans are assembled with series 300 stainless steel hardware, and all materials have been selected for the harsh cooling tower environment.

Marley fans are applied in accordance with data from model tests conducted in the wind tunnel at the SPX Cooling Technologies' Research and Development Center. Model fan designs are tested in simulated cooling towers, and are fine-tuned to maximize efficiencies at actual conditions. The commercially available fans used by other cooling tower suppliers lack this design advantage. Consequently, they are often applied at flow and pressure conditions for which they are ill suited. Unpredictable lower efficiencies result, with proportional reduction in tower capacity.



### Fan Cylinder

Venturi-shaped FRP cylinders combine minimal entrance losses with close blade tip clearances to produce optimum fan performance. As cylinder heights increase, cylinders are progressively flared to promote recovery of velocity pressure—allowing fans to move the required amount of air at significantly reduced horsepower.

Unlike those used on other towers, Marley fan cylinders have exceptionally large entrance diameters which contribute to the "eased inlet" effect so necessary to good fan performance. Smaller entrances do not provide sufficient transition to deter turbulent flow at the fan. Marley fan cylinders are through-bolted to the fan deck and supporting framework. The combination of a large foundation "footprint" and through-bolting has enabled Marley fan cylinders to withstand wind velocities in which other fan cylinders have failed.



## Geareducer

The Marley Geareducer<sup>®</sup> has become the standard by which all other cooling tower fan speed reducers are judged. Numerous reduction ratios are available so that horsepower is applied at optimum fan speed. The specific Geareducer selection is based on fan speed and horsepower requirements up to 300 hp per fan.

Marley Geareducers are designed to meet or exceed the requirements of CTI (Cooling Tower Institute) STD-111 and AGMA Std. 420.04, and are run-in under load prior to shipment. Housings are gray cast iron (ASTM Class 20), heat-treatment stress relieved, and covered with two coats of epoxy-polyamide paint. Gears are high strength, case hardened alloy steel. All bearings are tapered roller bearings with minimum  $L_{10}$  service life of 100,000 hours. Service factors are at least 2.0 at applied horsepower. All Marley Geareducers are right-angle type with motors located outside the saturated effluent airstream.

Splash-type lubrication and integral cooling fins preclude the need for maintenance-intensive oil pumps and coolers. A constant oil bath or flow lubricates every bearing. Lubrication is maintained in forward or reverse motion—at full or half speed. Geareducers on Marley 600 towers are equipped with remote sight gauge and drain lines, which permit constant surveillance of oil level in each unit.

## Driveshaft

Marley-manufactured driveshafts transmit power from the motor to the Geareducer. All Marley driveshafts are manufactured from either carbon fiber composite or stainless steel tubes with stainless steel flanges. Bonded neoprene flexible elements transmit torque and require no lubrication. Marley driveshafts are full-floating assemblies with flexible couplings on each end. Their tolerance to misalignment and torsional shock is unequalled in non-specialized units. All Marley driveshafts are dynamically balanced at the factory to minimize operating vibrations.



## Unitized Support

The Marley torque-tube unitized support stabilizes the fan within the fan cylinder and maintains constant alignment between the motor and the Geareducer. It is a welded unit of large diameter pipe, heavy angles and plate, and hot dip galvanized after assembly. The large tube design locates the fan at its optimum operating elevation within the fan cylinder and provides excellent torsion resistance along all potential axes of movement. It is fastened to the wood structure through heavy wide flange beams. Formed retainers surround and contain the drive shafts.

In addition to superior strength and stability characteristics, the Marley torque-tube offers minimal airflow restriction in comparison to typical boxlike configurations. Its cylindrical shape also minimizes air turbulence in the fan entrance region.

## FILL



Marley 600 splash fill is available in the following materials:

- PVC in "Omega", "Mega" or "Alpha" configurations.
- Injection-molded polypropylene "Ladder" configurations.
- Rough sawn, preservative-treated wood "G" configurations.



Each cooling tower application is individually reviewed to assure selection of the proper fill type and fill spacing. Performance is computer optimized to assure maximum cooling from a given tower cell size for the design performance conditions.

Long functional life for cooling tower fill depends on the splash bar support. Wood lath and PVC splash bars are supported in FRP or polypropylene grids. Chemically, the resistance of FRP to acids, alkalis, salts, and oils is rated excellent through concentrations much higher than could ever occur in a cooling tower. Mechanically, the FRP support system takes advantage of tensile strength exceeding 30,000 psi. FRP exhibits very little creep under stress of live and dead loads throughout the extremes of moisture and temperature variations.

## WATER DISTRIBUTION SYSTEM

### Piping

Although side inlet piping is provided as standard, Marley 600 cooling towers are adaptable to end inlet piping. This is an economical method requiring only one riser for each series of hot water basins, regardless of the number of fan cells. Cast iron, steel, and reinforced plastic pipe are all available.



The open, gravity flow design allows the operator to vary water rates over a wide range while maintaining uniform water distribution to the fill—a prerequisite for reliable thermal performance. Open distribution allows easy access for quick, inexpensive maintenance and cleaning.



### Valves

Marley-built flow control valves used on Marley 600 cooling towers have proved their reliability in more than 60 years of service. The oversized valve body effectively dissipates velocity, providing uniform water distribution. Heavy-duty cast iron body and stainless steel valve stem assure long life and low maintenance.

### Splash Boxes

Each flow control valve discharges into a splash box located in the hot water basin. The lower box delivers water to the hot water basin both through slots in the bottom and by overflow. The cover box dissipates directional velocity and controls splash.



### Nozzles

The “spiral target nozzle” metering orifices used in the hot water basins are specially designed to deliver the required water rate and are highly resistant to temperature and weathering damage. The use of “target nozzles” also provides uniform water distribution throughout the fill area with no need for a separate diffusion deck.



## DRIFT ELIMINATOR

Marley towers utilize Marley XCEL<sup>®</sup> TU drift eliminators, a cellular, labyrinthine design which improves drift elimination by several orders of magnitude over that achievable by blade-type eliminators. Significantly lower pressure losses also reduce fan horsepower requirements.

XCEL eliminators are thermoformed PVC bonded into easily handled, rigid packs which "nest" together to seal against drift bypass. Packs are clamped in place at each girt line, and are self-supporting between girt lines. No additional structure is required to support the eliminators. Corrosion and chemical resistant plastic drain boards return all water stripped from the air to the fill chamber.



## TOWER STRUCTURE\*

Marley 600 wood cooling towers are designed in accordance with the latest edition of the National Design Specification for Wood Construction (NDS) published by the National Forest Products Association, and CTI STD-114. Wind load criterion is per ASCE-7, and stability is based upon an applied lateral load of 2.5% of the total operating weight. Allowable stress values for all lumber are reduced for wet service, temperature, and duration as appropriate.

Unless otherwise specified, all lumber regardless of species is pressure treated after fabrication. Treatment is Copper Chromate Arsenate (CCA), infused into the wood as specified by CTI STD-112.

The design is based on 4'-0" x 8'-0" modules. Transverse bents consist of 4" x 4" columns spaced on 8'-0" centers. Transverse bent lines are spaced on 4'-0" centers longitudinally.



Transverse fan deck and hot water basin girts are 2" x 6"—all other transverse girts and all longitudinal girts are 2" x 4" except where loading may require 3" x 4". Transverse and longitudinal girts are spaced on 6'-0" vertical centers. Girt lines are through bolted to the columns.

Transverse and longitudinal diagonals are 4" x 4" members spliced across tower columns with FRP connectors. The connectors transmit lateral loads from girts to diagonals and columns.

\*Marley 600 cooling towers are also available with pultruded FRP structure design. For more information download a copy of SPEC-F600 at [spxcooling.com](http://spxcooling.com)





The diagonals brace the structure and carry loads to heavy-duty, hot dip galvanized anchor castings. The anchor castings transmit wind and/or earthquake loads from the structure directly into the foundation.

For standard wind load conditions, anchor bolts are required only at the perimeter.

Structural ceramic rings or glass reinforced nylon shear plates are used in conventional connector ring joints where greater strength is required than bolted joints provide. Permissible joint loads are based on Forest Products Laboratory test values established by procedures for commercial ring connectors.

The fan deck is pressure treated exterior grade tongue-and-groove fir plywood designed for a uniform load of 60 psf, or a 600 pound concentrated live load.

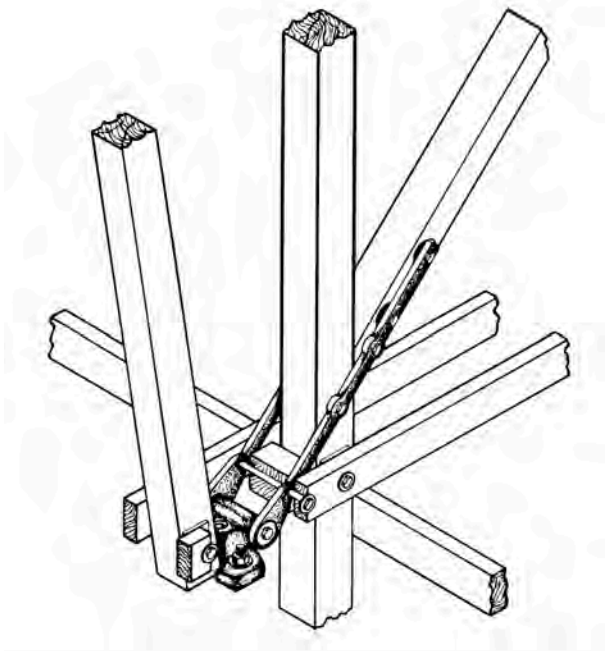

## CASING

The endwalls of Marley 600 towers are cased from the fan deck level to below the top of the basin curb with 8 oz/sq ft corrugated FRP sheets. FRP is waterproof and corrosion proof, is immune to biological deterioration, and requires no maintenance. Sheets are installed on maximum 4'-0" spans with corrugations running horizontally. Vertical joints are lapped and sealed. Horizontal joints are lapped one corrugation to shed water inward. The casing is attached to structural members with stainless steel screw shank fasteners, complete with neoprene bonded washers. Corner trim pieces are 12 oz/sq ft molded FRP.



## LOUVERS

42" wide louver blades, made of 9 oz/sq ft corrugated FRP, prevent splash out. Exterior grade plywood louvers are used in freezing climates. Continuous 2" x 4" members beneath the louvers provide bearing across the entire louver width. These supports are rigidly framed into louver posts by through bolting at the bottom and are tied near the top by molded structural polypropylene tie bars.

Louvers are supported on 4'-0" centers by 4" x 4" structural columns. This scheme provides more than twice the bending strength compared to designs utilizing 6'-0" spans.

The relationship between the louvers and the direction of water flow results in a uniform, light water cascade down the inboard edge of the louvers. This cascade protects the fill from ice formation and possible damage.

Standard FRP louvers are positioned on 4'-0" vertical centers. Plywood louvers used in freezing climates are positioned on 3'-0" vertical centers. This spacing eliminates stagnant areas in the fill, thereby reducing the tendency for fine moisture particles to form sheet ice, plugging air inlets.

## MAINTENANCE OPTIONS



### Endwall Derrick

The endwall derrick is a permanently installed tripod device of galvanized structural steel. In service, removable structural aluminum tracks are positioned across the platform opening. Equipment to be handled is placed on a 4-wheel dolly—part of the equipment handling package—rolled onto the track and elevated slightly. The track and dolly are removed and the equipment lowered to grade level. With single sheave rigging, the derrick will handle loads up to 3000 pounds—the weight of a large Geareducator—normally the single heaviest component in the mechanical equipment package. Cable and power for rigging are not normally provided by SPX.

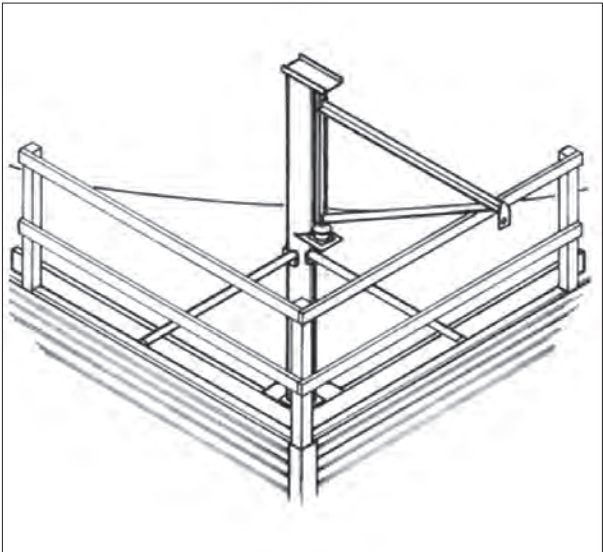

### Endwall Davit

The endwall davit is offered for Marley 600 towers equipped with smaller Geareducators (Series 27 and smaller). This galvanized steel hoisting device is permanently installed at a corner of the fan deck and is rated for a load of 1000 pounds with single sheave rigging. The rotating arm is mounted with protected ball bearing joints for easy travel under load. Reach from centerline of the vertical post to the hook-eye is 6'-0". Clear height from fan deck to the hook-eye is 8'-6". Removable guard and knee rails are installed at the landing point. Rigging apparatus is not normally provided by SPX.

SPX Cooling Technologies is dedicated to satisfying the needs of our customers—needs which begin far in advance of the actual purchase of a new Marley cooling tower, and vary over the operating lifetime of the project. Here is a partial listing of the additional services offered by SPX Cooling Technologies to help you do your job most effectively:

**Application/Sizing/Layout Services**—Sales Engineers are trained to help you choose the proper type and size of cooling tower, and will guide you in its appropriate location on site. They will also help you write the specifications for its purchase. As the only manufacturer who makes all types of cooling products, SPX Cooling Technologies can offer you a wide range of options to meet your requirements.

**Construction Service**—We can supply supervision only—or a complete, experienced crew to handle construction.

**Parts Service**—We maintain a stock of spare parts specific to your Marley tower.

**Maintenance Service**—In addition to providing complete instructions and continuing guidance, we will provide as much “hands on” maintenance as you require, or will recommend a local service contractor for your consideration.

**Condition Inspection Service**—From time to time, for your peace of mind, our engineers can give your tower a thorough inspection to evaluate its current condition. This usually allows you to foresee and forestall problems before they become serious.

**Reconstruction Service**—Due to operating or atmospheric conditions, or age, sooner or later your tower will be in need of repairs above and beyond those categorized as normal maintenance. Our reconstruction service can return your tower to as new condition

**Performance Improvement Service**—Systems served by cooling towers grow in response to demand for the product produced by that system. Most customers find that they could produce more product if the cooling tower could deliver colder water. Fortunately, cooling tower technology advances with time, and we can apply this increased technology to upgrade your tower’s thermal performance.

**Tower Replacement Service**—Occasionally, customers will benefit from replacing an installed tower, rather than refurbishing it. SPX Cooling Technologies stands ready to assist you in that endeavor—and, in most cases, the replacement will require little or no change to your concrete basin or support structure.

**SPX COOLING TECHNOLOGIES, INC.**

7401 WEST 129 STREET  
OVERLAND PARK, KS 66213 USA  
913 664 7400 | [spxcooling@spx.com](mailto:spxcooling@spx.com)  
[spxcooling.com](http://spxcooling.com)

600-13 | ISSUED 10/2016

COPYRIGHT © 2016 SPX CORPORATION

In the interest of technological progress, all products are subject to design and/or material change without notice.

