

Unité sans conduit

# SIMPLE-ZONE

12  
ANS  
GARANTIE  
COMPRESSEUR

12  
ANS  
GARANTIE  
PIÈCES

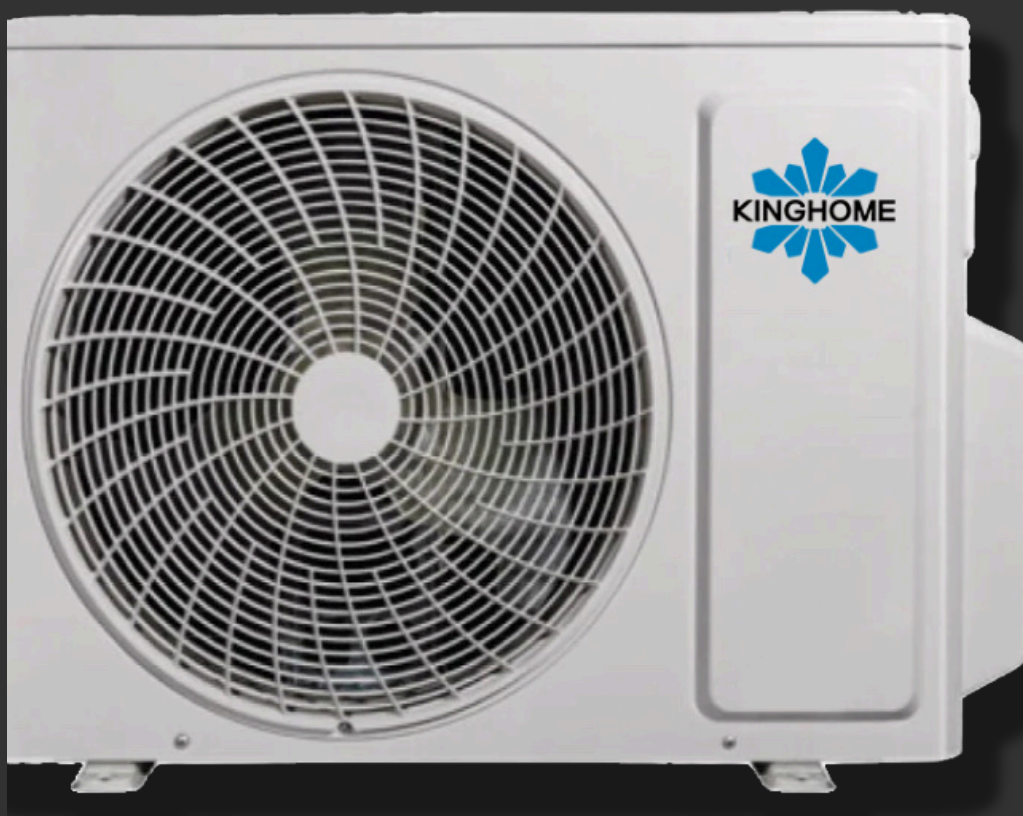

Jusqu'à  
30 SEER2  
11.2 HSPF2

Plage de refroidissement

-29°C ~ 50°C

Plage de Chauffage

-30°C ~ 30°C



**Fonction silencieuse:** Aussi bas que 19 dB(A).

**Idéal pour les espaces sans conduit:** Design compact et élégant, facilitant une installation simple dans divers environnements intérieurs.

**Contrôle intelligent:** Équipé d'option de contrôle intelligent pour une utilisation pratique et une gestion énergétique efficace.

LE NOUVEAU RÉFRIGÉRANT R32 PROCURE UNE PERFORMANCE ÉLEVÉE, MÊME DANS DES CONDITIONS À BASSE TEMPÉRATURE.

DE -30 °C À 50°C



R32



Caractéristiques	Charmo	Clivia	Airy
Plage de capacité (nominale)	9K - 36K	9K - 24K	9K - 24K
Réfrigérant	R32		
Type de compresseur	Rotatif / Double Rotatif	Rotatif	Rotatif / Double Rotatif
Alimentation électrique	208-230 / 1Ph / 60Hz	208-230 / 1Ph / 60Hz	208-230 / 1Ph / 60Hz
Alimentation 115V en option	9K & 12K	9K & 12K	Non
SEER 2	Jusqu'à 22	Jusqu'à 27	Jusqu'à 30
EER 2	Jusqu'à 12.5	Jusqu'à 15	Jusqu'à 16.8
HSPF 2	Jusqu'à 9	Jusqu'à 10.5	Jusqu'à 11.2
Plage de température en refroidissement	-18 ~ 48°C (0 ~ 118°F)	-29 ~ 50°C (-20 ~ 122°F)	-29 ~ 50°C (-20 ~ 122°F)
Plage de température en chauffage	-25 ~ 24°C (-13 ~ 75°F)	-30 ~ 30°C (-22 ~ 86°F)	-30 ~ 30°C (-22 ~ 86°F)
Niveau sonore intérieure (refroidissement/chauffage)	Jusqu'à 24 dB(A)	Jusqu'à 20 dB(A)	Jusqu'à 19 dB(A)
Niveau sonore extérieure (refroidissement/chauffage)	Jusqu'à 51 dB(A)	Jusqu'à 52 dB(A)	Jusqu'à 55 dB(A)
Télécommande	Incluse	Incluse	Incluse
Contrôleur filaire (chauffage auxiliaire externe)	En option	En option	En option
Option d'air frais MiniERV'	Non	Oui	Non
Vitesses multiples		Oui (Toutes les séries)	
Oscillation automatique		Oui (Toutes les séries)	
I Feel		Oui (Toutes les séries)	
Nettoyage automatique		Oui (Toutes les séries)	
Mode Turbo		Oui (Toutes les séries)	
Dégivrage		Oui (Toutes les séries)	
Capteur de détection de réfrigérant		Oui (Toutes les séries)	
Wi-Fi		Oui (Toutes les séries)	
Garantie limitée	12 ans pour application résidentielle, 7/5 ans pour application commerciale (compresseur et pièces)		



## MiniERV

### Kit d'air frais

Ventilation bi-directionnel innovatrice procurant **17.6 CFM**

- Récupérateur d'énergie allant jusqu'à 1Kw/h par jour.
- Niveau sonore aussi bas que 19dB(A)
- Entretien facile

Thermostat XE71-00/E

Télécommande



(Optionnel)



(Inclus)



kinghomecanada.com

Concessionnaire Autorisé



# Submittal-Charmo 12K 115V Minisplit

Job name:		Submitted by:	
Location:		Submitted to:	
Engineer:		Unit tag:	
Date:		Drawing number:	

## Warranty information

Standard 7 years parts & compressor  
 Registered 12 years parts & compressor  
 Terms and conditions apply

## Type

Energy Star Heat Pump

Cold Climate Energy Star Heat Pump

## Model numbers

Indoor: KW12HQ19CAI

Outdoor: KW12HQ19CAO

## Capacity range

Output (BTU/H)	Minimum	Rated	Max	Certification		
Cooling:	3070	12000	13300	AHRI NO.	Energy Star	
Heating:	3070	12000	14600			

## Heating performance

Output (BTU/H)	Minimum	Rated	Max
47F (8.3C)			
17F (-8.3C)			
5F (-15C)			

## Efficiency Ratings

SEER2	19
HSPF2	8.5
EER (W/W)	2.85
COP (W/W)	3.5

## Outdoor temperature range

Cooling:	-18-48C	0-118F
Heating:	-25-24C	-13-75F

## Electrical

Power supply	115V/60Hz/1Ph
Min/Max voltage	103-126Vac

## Condenser specifications

Connecting type	Screw Connection
Liquid line size	1/4in (6mm)
Gas line size	3/8in (9.52mm)
pre-charge length	24.6ft (7.5M)
MIN. Refrigerant Pipe Length	10 ft (3M)
MAX. Refrigerant Pipe Length	100 ft (30M)
MAX. Vertical Height difference (total)	60 ft (20M)

MCA	19A
MOP	20A
Power Supply Wire	12/3 AWG
Interconnecting Wire	14/4 AWG

## Features:

Capillary Expansion
Rotary compressor
Basepan heater
Compressor electric heater

Refrigerant Type	R-32
Factory Charge	17.6 oz
Additional Charge	0.2 oz/ft
Sound Pressure Level	52dB (A)

Weight	
Gross weight:	60.6Lbs (27.5Kg)
Net weight:	55.1Lbs (25Kg)



R32



20 Inverter

AHRI

Specifications are subject to change without notice. Manufacturer reserves the right to discontinue or modify specifications or designs without notice or without incurring obligations. All Rights reserved.



# Outdoor unit Dimensions

KW12HQ19CAO

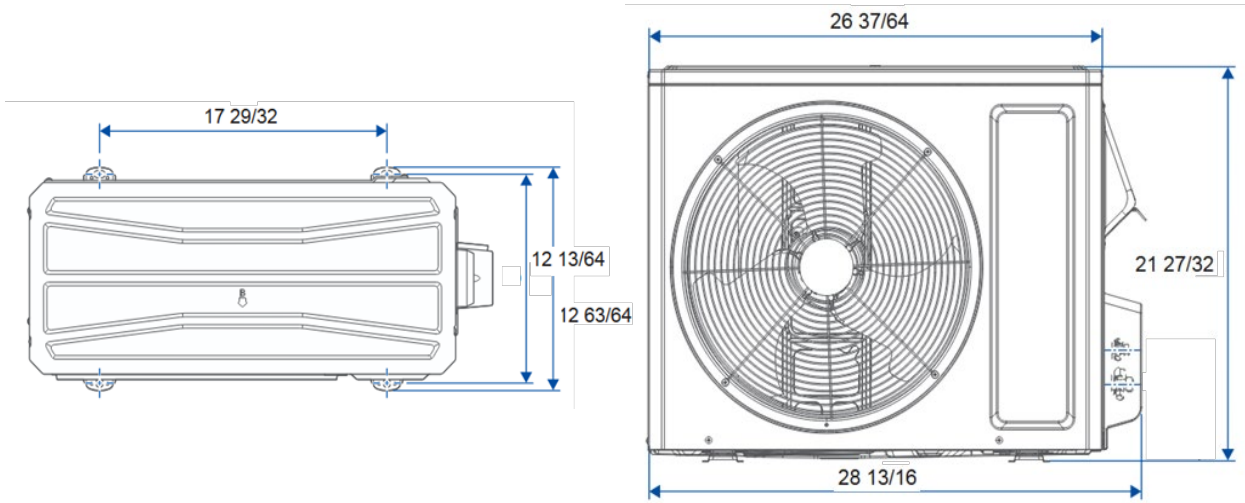

## Minimum outdoor unit clearances

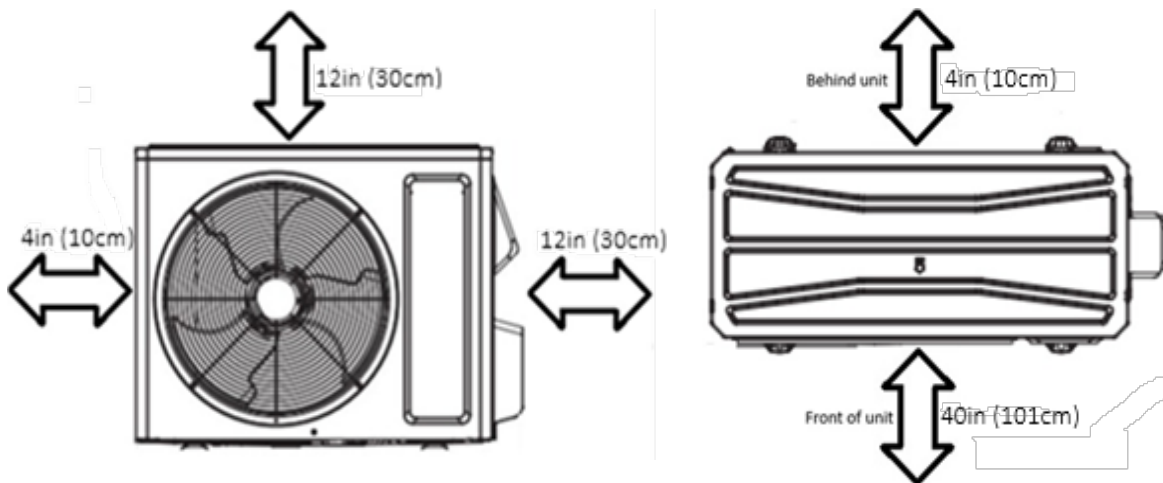

Unit must be placed a minimum 18in (45cm) above any surfaces to allow for snow clearance and defrost runoff.

Please follow local best practices and guidelines.

Specifications are subject to change without notice. Manufacturer reserves the right to discontinue or modify specifications or designs without notice or without incurring obligations. All Rights reserved.



# Indoor unit specifications

KW12HQ19CAI

Air flow volume			dB (A)
Turbo	424 CFM	700 m3/h	47
High	353 CFM	600 m3/h	39
Med-high	324 CFM	550 m3/h	38
Medium	277 CFM	470 m3/h	35
Med-low	247 CFM	420 m3/h	33
Low	224 CFM	380 m3/h	32
Sleep	182 CFM	310 m3/h	27

Net weight:	20.9 Lbs	Gross weight:	24.3 Lbs
	9 Kg		11.5 Kg
Included:	Infrared remote YBE1FBB		
Dehumidification level:	2.96pt/hr		
<b>Optional Accessories</b>			
24V interlock wired controller:	XE71-00/E		
Wired controller:	XE71-44G		
Embedded wired controller:	XE74-44E		
Embedded WIFI wired controller	XE72-44E		

### Included Features

WI-FI control	8C heating	I-feel	Self clean	Forced defrost	Soft start	Low voltage startup
---------------	------------	--------	------------	----------------	------------	---------------------

### Indoor unit Dimensions

Unit: inch

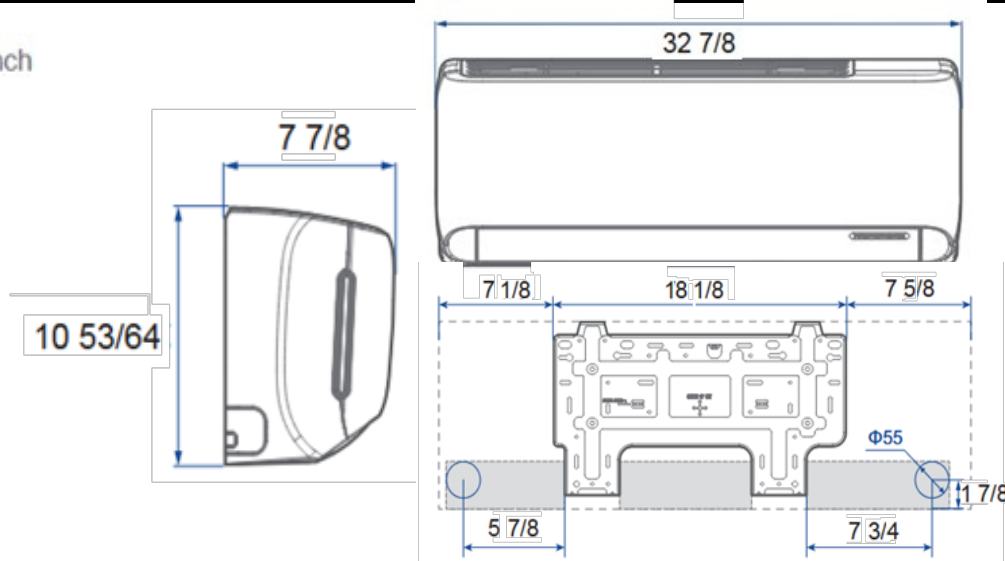

### Minimum indoor unit clearances

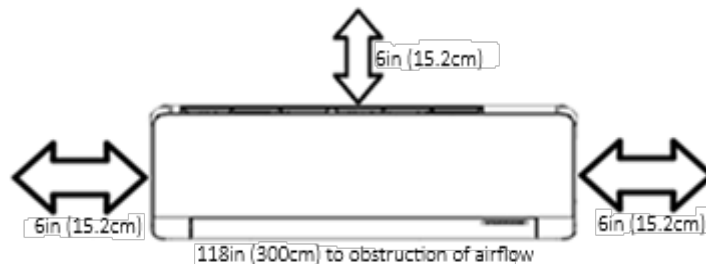

Specifications are subject to change without notice. Manufacturer reserves the right to discontinue or modify specifications or designs without notice or without incurring obligations. All Rights reserved.



# Submittal-Charmo 9K Minisplit

Job name:		Submitted by:	
Location:		Submitted to:	
Engineer:		Unit tag:	
Date:		Drawing number:	

## Warranty information

Standard 7 years parts & compressor  
 Registered 12 years parts & compressor  
 Terms and conditions apply

## Type

Energy Star Heat Pump

Cold Climate Energy Star Heat Pump

## Model numbers

Indoor: KW09HQ19CDI

Outdoor: KW09HQ19CDO

## Capacity range



R32



20 Inverter

AHRI

Output (BTU/H)	Minimum	Rated	Max	Certification		
Cooling:	2388	9100	10300	AHRI NO.	Energy Star	nep
Heating:	2217	10000	13136	217903552	4,514,229.	
Heating performance				Efficiency Ratings		
Output (BTU/H)	Minimum	Rated	Max	SEER2	20.5	
47F (8.3C)	2300	10000	12000	HSPF2	8.8	
17F (-8.3C)	1800	9600	9600	EER (W/W)	3.6	
5F (-15C)	1500	7600	7600	COP (W/W)	3.8	
Outdoor temperature range			Electrical			
Cooling:	-18-48C	0-118F		Power supply	208-230V/60Hz/1Ph	
Heating:	-25-24C	-13-75F		Min/Max voltage	187-253Vac	
Condenser specifications			MCA			
Connecting type		Screw Connection		MOP	15A	
Liquid line size		1/4in (6mm)		Power Supply Wire	14/3 AWG	
Gas line size		3/8in (9.52mm)		Interconnecting Wire	14/4 AWG	
pre-charge length		24.6ft (7.5M)		Features:		
MIN. Refrigerant Pipe Length		10 ft (3M)		Capillary Expansion		
MAX. Refrigerant Pipe Length		100 ft (30M)		Rotary compressor		
MAX. Vertical Height difference (total)		60 ft (20M)		Basepan heater		
Refrigerant Type		R-32		Compressor electric heater		
Factory Charge		18.7 oz		Weight		
Additional Charge		0.2 oz/ft		Gross weight:	60.6Lbs (27.5Kg)	
Sound Pressure Level		51dB (A)		Net weight:	55.1Lbs (25Kg)	

Specifications are subject to change without notice. Manufacturer reserves the right to discontinue or modify specifications or designs without notice or without incurring obligations. All Rights reserved.



# Outdoor unit Dimensions

KW09HQ19CDO

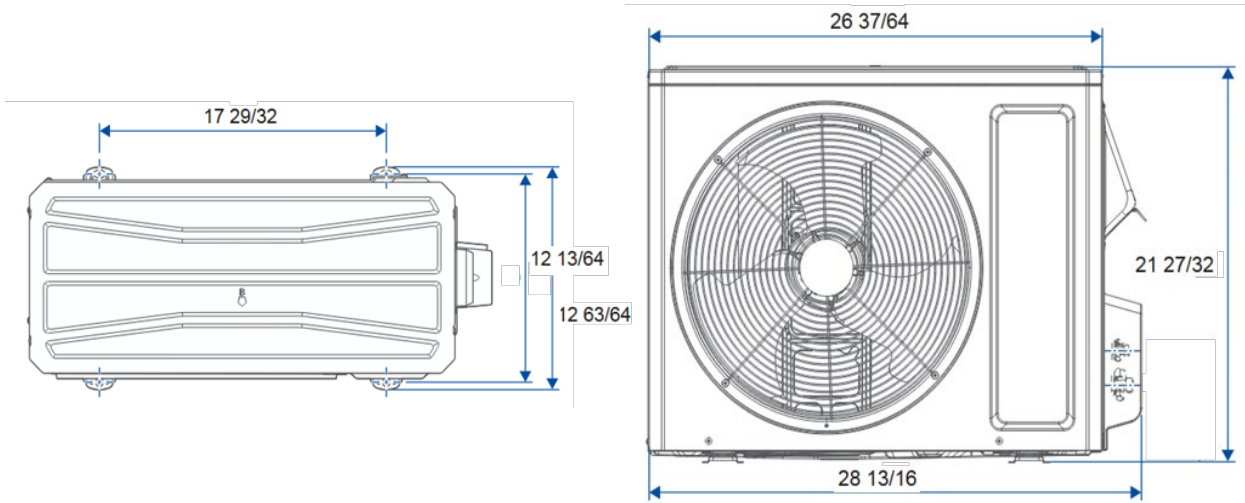

## Minimum outdoor unit clearances

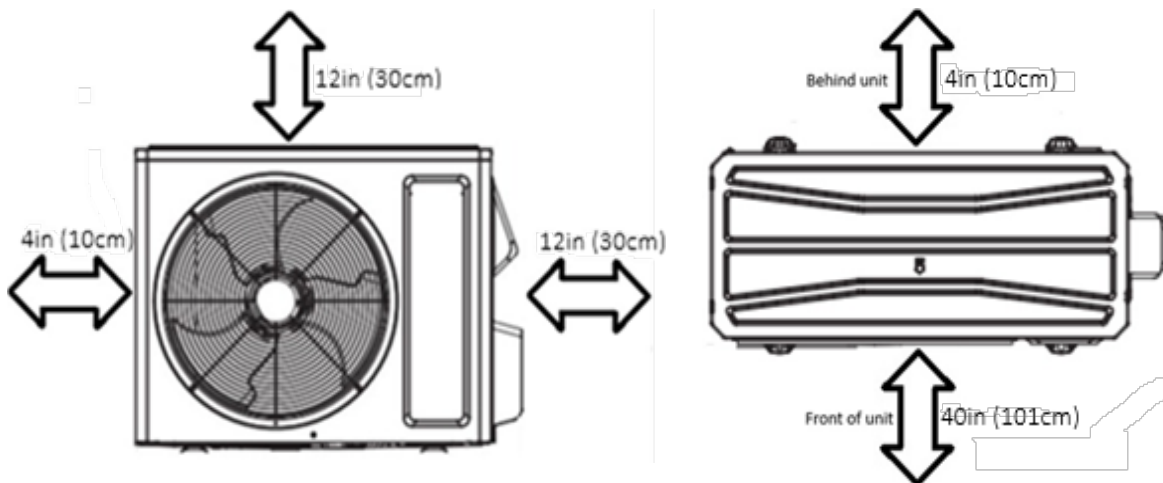

Unit must be placed a minimum 18in (45cm) above any surfaces to allow for snow clearance and defrost runoff.

Please follow local best practices and guidelines.

Specifications are subject to change without notice. Manufacturer reserves the right to discontinue or modify specifications or designs without notice or without incurring obligations. All Rights reserved.



# Indoor unit specifications

KW09HQ19CDI

Air flow volume			dB (A)
Turbo	353 CFM	600 m3/h	41
High	282 CFM	480 m3/h	37
Med-high	265 CFM	450 m3/h	34
Medium	230 CFM	390 m3/h	32
Med-low	212 CFM	360 m3/h	31
Low	194 CFM	330 m3/h	27
Sleep	159 CFM	270 m3/h	24

Net weight:	20.9 Lbs	Gross weight:	24.3 Lbs
	9 Kg		11.5 Kg
Included:	Infrared remote YBE1FBF		
Dehumidification level:	1.69 pt/hr		
<b>Optional Accessories</b>			
24V interlock wired controller:	XE71-00/E		
Wired controller:	XE71-44G		
Embedded wired controller:	XE74-44E		
Embedded WIFI wired controller	XE72-44E		

### Included Features

WI-FI control	8C heating	I-feel	Self clean	Forced defrost	Soft start	Low voltage startup
---------------	------------	--------	------------	----------------	------------	---------------------

### Indoor unit Dimensions

Unit: inch

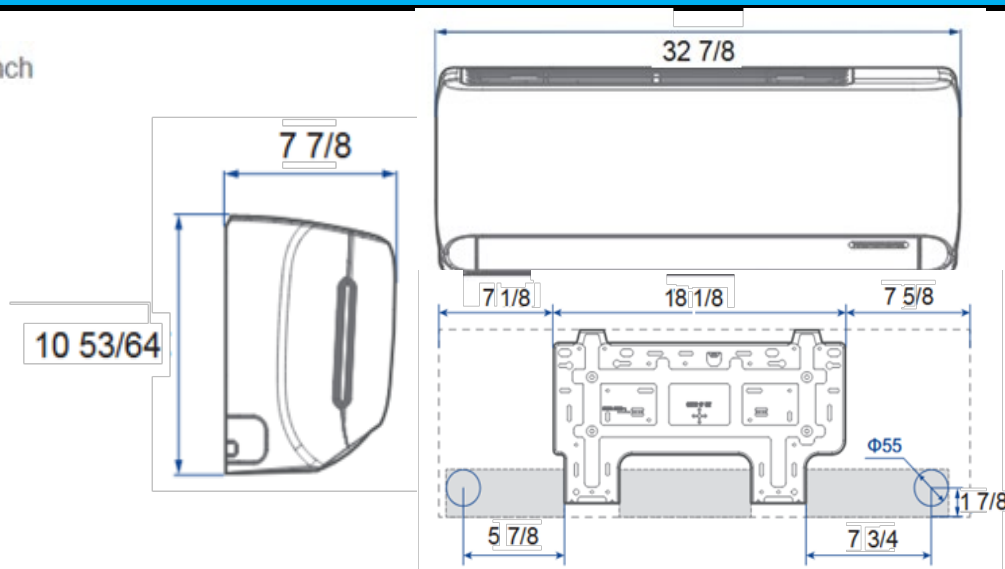

### Minimum indoor unit clearances

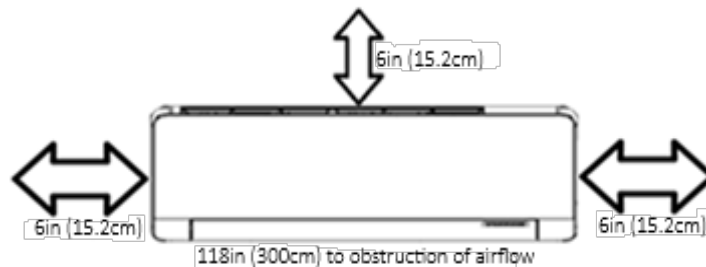

Specifications are subject to change without notice. Manufacturer reserves the right to discontinue or modify specifications or designs without notice or without incurring obligations. All Rights reserved.



# Submittal-Charmo 12K Minisplit

Job name:		Submitted by:	
Location:		Submitted to:	
Engineer:		Unit tag:	
Date:		Drawing number:	

## Warranty information

Standard 7 years parts & compressor  
 Registered 12 years parts & compressor  
 Terms and conditions apply

## Type

Energy Star Heat Pump

Cold Climate Energy Star Heat Pump

## Model numbers

Indoor: KW12HQ19CDI

Outdoor: KW12HQ19CDO

## Capacity range



R32



20 Inverter

AHRI

Output (BTU/H)	Minimum	Rated	Max	Certification		
Cooling:	3070	12000	13300	AHRI NO.	Energy Star	nep
Heating:	3070	12000	14600	217956851	4,514,328.	
Heating performance				Efficiency Ratings		
Output (BTU/H)	Minimum	Rated	Max	SEER2	19	
47F (8.3C)	3070	12000	12000	HSPF2	8.5	
17F (-8.3C)	2700	9700	11500	EER (W/W)	2.85	
5F (-15C)	2600	9100	9100	COP (W/W)	3.5	
Outdoor temperature range				Electrical		
Cooling:	-18-48C	0-118F		Power supply	208-230V/60Hz/1Ph	
Heating:	-25-24C	-13-75F		Min/Max voltage	187-253Vac	
Condenser specifications				MCA	12A	
Connecting type		Screw Connection		MOP	15A	
Liquid line size		1/4in (6mm)		Power Supply Wire	14/3 AWG	
Gas line size		3/8in (9.52mm)		Interconnecting Wire	14/4 AWG	
pre-charge length		24.6ft (7.5M)		Features:		
MIN. Refrigerant Pipe Length		10 ft (3M)		Capillary Expansion		
MAX. Refrigerant Pipe Length		100 ft (30M)		Rotary compressor		
MAX. Vertical Height difference (total)		60 ft (20M)		Basepan heater		
Refrigerant Type		R-32		Compressor electric heater		
Factory Charge		17.6 oz		Weight		
Additional Charge		0.2 oz/ft		Gross weight:	60.6Lbs (27.5Kg)	
Sound Pressure Level		52dB (A)		Net weight:	55.1Lbs (25Kg)	

Specifications are subject to change without notice. Manufacturer reserves the right to discontinue or modify specifications or designs without notice or without incurring obligations. All Rights reserved.



# Outdoor unit Dimensions

KW12HQ19CDO

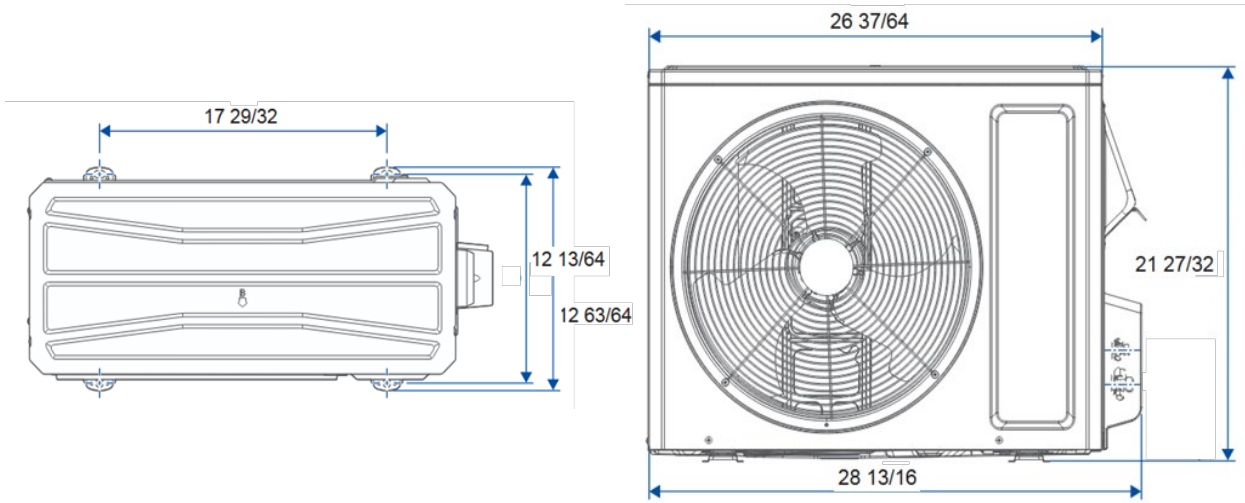

## Minimum outdoor unit clearances

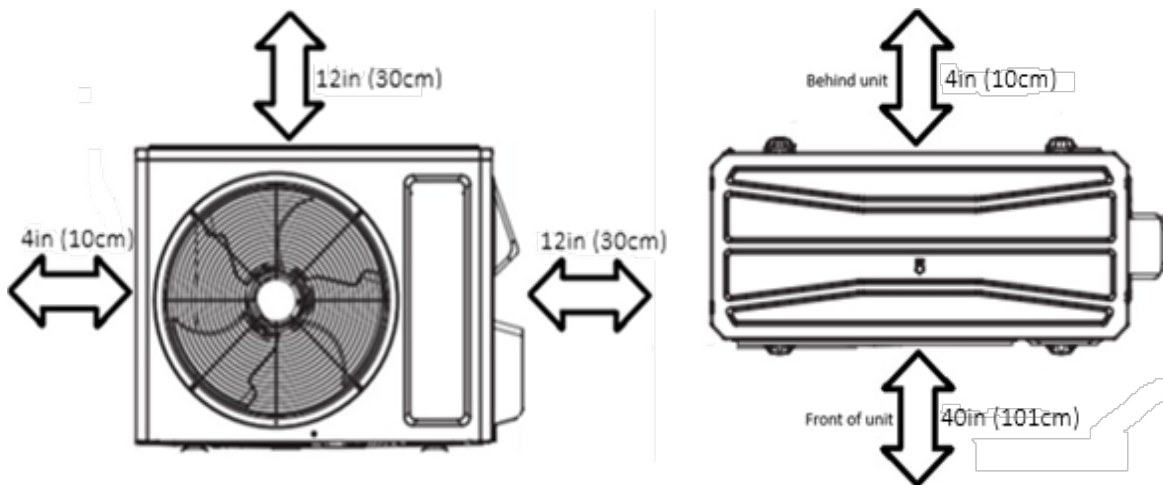

Unit must be placed a minimum 18in (45cm) above any surfaces to allow for snow clearance and defrost runoff.

Please follow local best practices and guidelines.

Specifications are subject to change without notice. Manufacturer reserves the right to discontinue or modify specifications or designs without notice or without incurring obligations. All Rights reserved.



# Indoor unit specifications

KW12HQ19CDI

Air flow volume			dB (A)
Turbo	424 CFM	700 m3/h	47
High	353 CFM	600 m3/h	39
Med-high	324 CFM	550 m3/h	38
Medium	277 CFM	470 m3/h	35
Med-low	247 CFM	420 m3/h	33
Low	224 CFM	380 m3/h	32
Sleep	182 CFM	310 m3/h	27

Net weight:	20.9 Lbs	Gross weight:	24.3 Lbs
	9 Kg		11.5 Kg
Included:	Infrared remote YBE1FBF		
Dehumidification level:	2.96pt/hr		
<b>Optional Accessories</b>			
24V interlock wired controller:	XE71-00/E		
Wired controller:	XE71-44G		
Embedded wired controller:	XE74-44E		
Embedded WIFI wired controller	XE72-44E		

### Included Features

WI-FI control	8C heating	I-feel	Self clean	Forced defrost	Soft start	Low voltage startup
---------------	------------	--------	------------	----------------	------------	---------------------

### Indoor unit Dimensions

Unit: inch

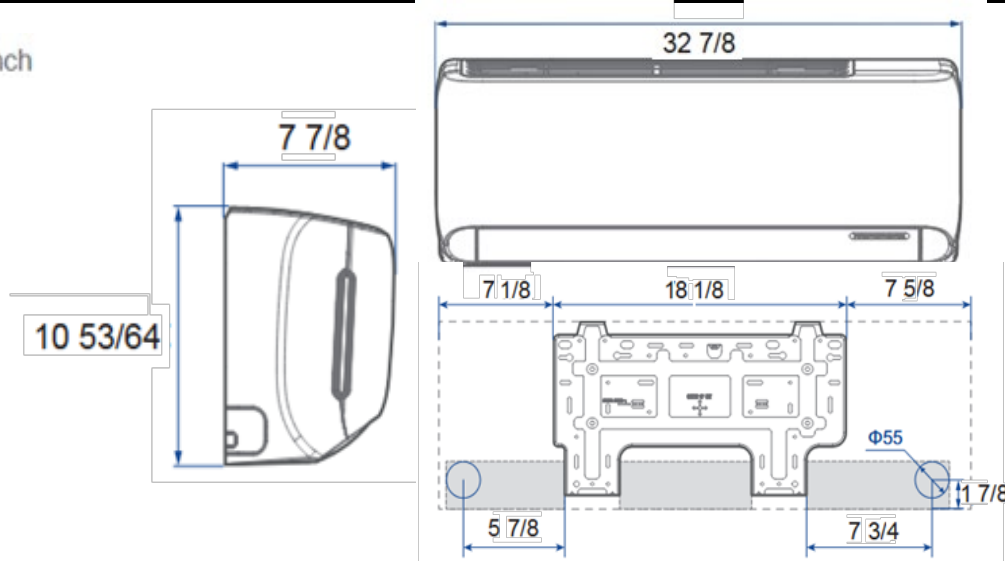

### Minimum indoor unit clearances

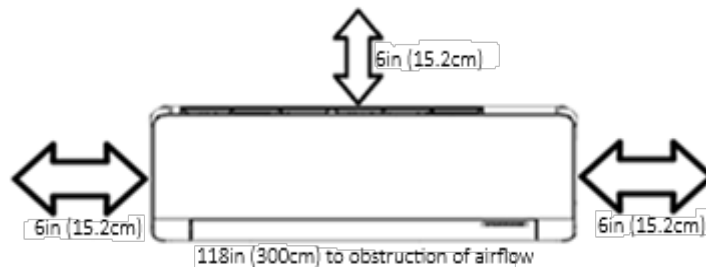

Specifications are subject to change without notice. Manufacturer reserves the right to discontinue or modify specifications or designs without notice or without incurring obligations. All Rights reserved.



# Submittal-Charmo 18K Minisplit

Job name:		Submitted by:	
Location:		Submitted to:	
Engineer:		Unit tag:	
Date:		Drawing number:	

## Warranty information

Standard 7 years parts & compressor  
 Registered 12 years parts & compressor  
 Terms and conditions apply

## Type

Energy Star Heat Pump

Cold Climate Energy Star Heat Pump

## Model numbers

Indoor:	KW18HQ19CDI
Outdoor:	KW18HQ19CDO

## Capacity range

Output (BTU/H)	Minimum	Rated	Max	Certification		
Cooling:	3753	18000	20300	AHRI NO.	Energy Star	nep
Heating:	2730	19100	22500	218029881	4,520,600.	

## Heating performance

Output (BTU/H)	Minimum	Rated	Max
47F (8.3C)	7000	17000	22500
17F (-8.3C)	7000	15300	15400
5F (-15C)	7000	12100	12100

## Efficiency Ratings

SEER2	20
HSPF2	8.5
EER (W/W)	3.52
COP (W/W)	3.9

## Outdoor temperature range

Cooling:	-18-48C	0-118F
Heating:	-25-24C	-13-75F

## Electrical

Power supply	208-230V/60Hz/1Ph
Min/Max voltage	187-253Vac

## Condenser specifications

Connecting type	Screw Connection
Liquid line size	1/4in (6mm)
Gas line size	1/2in (12mm)
pre-charge length	24.6ft (7.5M)
MIN. Refrigerant Pipe Length	10 ft (3M)
MAX. Refrigerant Pipe Length	131ft (40M)
MAX. Vertical Height difference (total)	82 ft (25M)
Refrigerant Type	R-32
Factory Charge	32.5 oz
Additional Charge	0.2 oz/ft
Sound Pressure Level	57dB (A)

MCA	13A
MOP	15A
Power Supply Wire	14/3 AWG
Interconnecting Wire	14/4 AWG

## Features:

Capillary Expansion
Rotary compressor
Basepan heater
Compressor electric heater

## Weight

Gross weight:	60.6Lbs (27.5Kg)
Net weight:	55.1Lbs (25Kg)



Specifications are subject to change without notice. Manufacturer reserves the right to discontinue or modify specifications or designs without notice or without incurring obligations. All Rights reserved.



# Outdoor unit Dimensions

KW18HQ19CDO

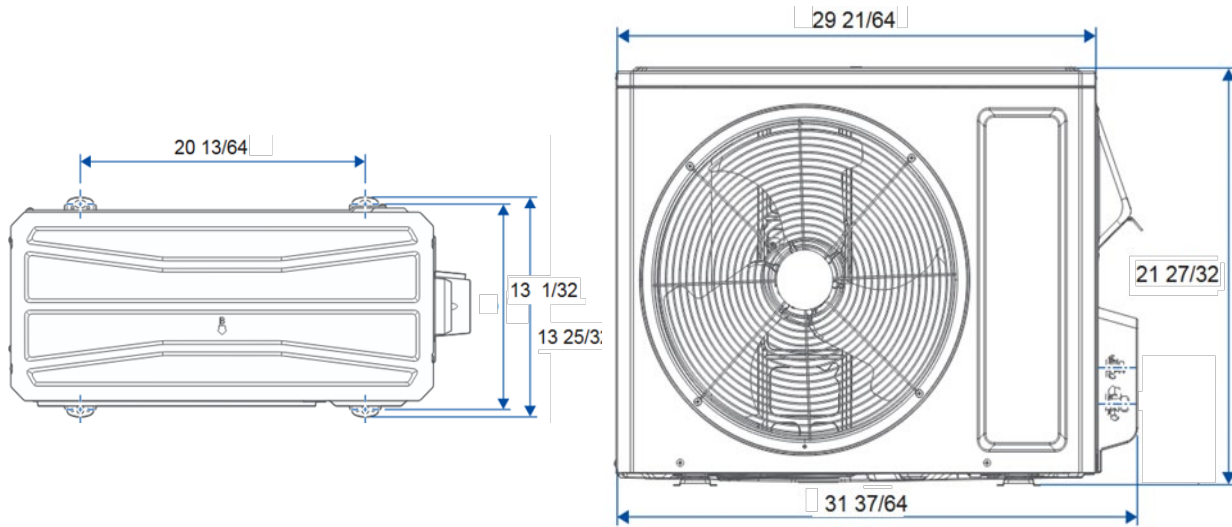

## Minimum outdoor unit clearances

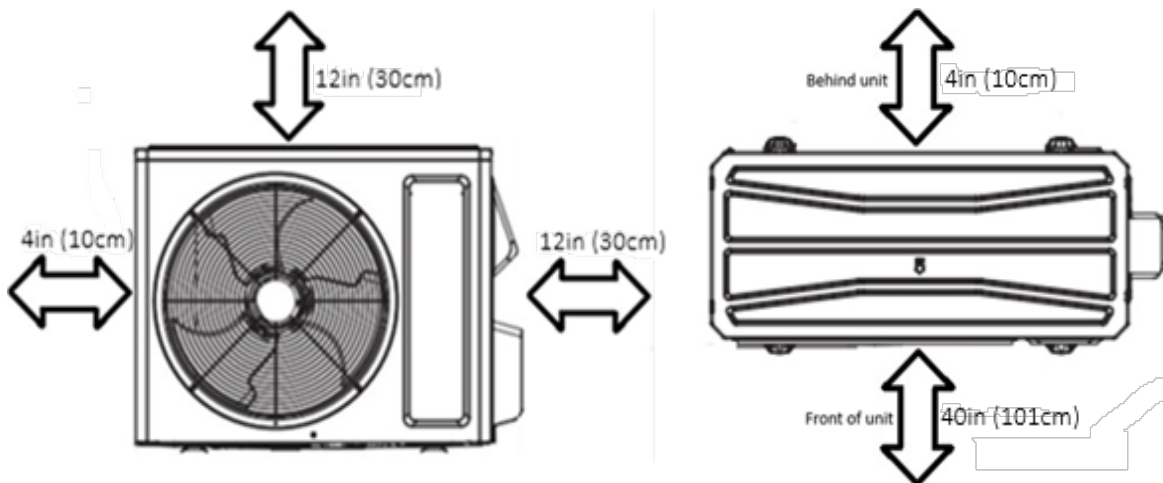

Unit must be placed a minimum 18in (45cm) above any surfaces to allow for snow clearance and defrost runoff.

Please follow local best practices and guidelines.

Specifications are subject to change without notice. Manufacturer reserves the right to discontinue or modify specifications or designs without notice or without incurring obligations. All Rights reserved.



# Indoor unit specifications

KW18HQ19CDI

Air flow volume			dB (A)
Turbo	618 CFM	1050 m3/h	53
High	512 CFM	870 m3/h	49
Med-high	471 CFM	800 m3/h	46
Medium	435 CFM	740 m3/h	44
Med-low	394 CFM	670 m3/h	42
Low	335 CFM	570 m3/h	38
Sleep	282 CFM	480 m3/h	34

Net weight:	28.7 Lbs	Gross weight:	34.2 Lbs
	13 Kg		15.5 Kg
Included:	Infrared remote YBE1FBF		
Dehumidification level:	3.8 pt/hr		
<b>Optional Accessories</b>			
24V interlock wired controller:	XE71-00/E		
Wired controller:	XE71-44G		
Embedded wired controller:	XE74-44E		
Embedded WIFI wired controller	XE72-44E		

### Included Features

WI-FI control	8C heating	I-feel	Self clean	Forced defrost	Soft start	Low voltage startup
---------------	------------	--------	------------	----------------	------------	---------------------

### Indoor unit Dimensions

Unit: inch

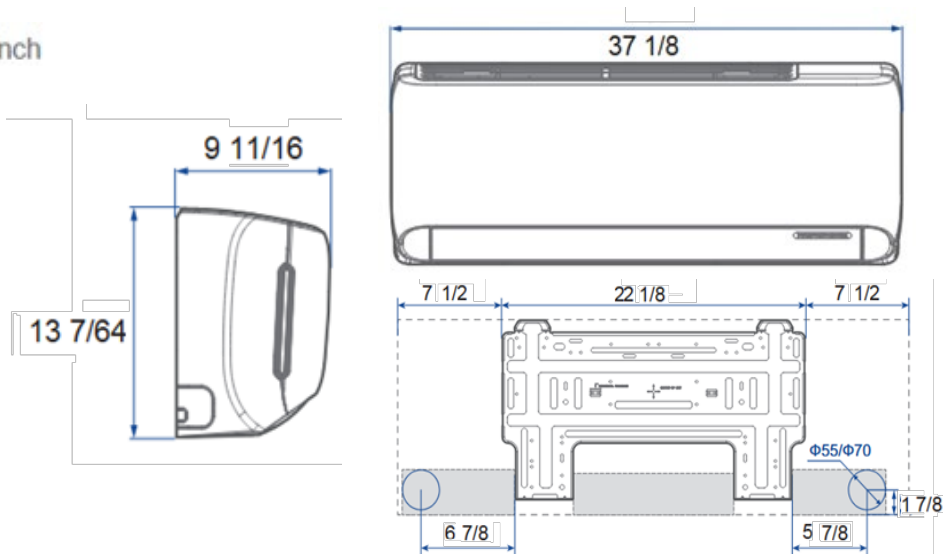

### Minimum indoor unit clearances

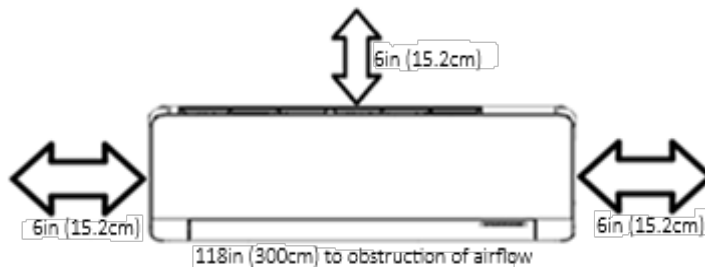

Specifications are subject to change without notice. Manufacturer reserves the right to discontinue or modify specifications or designs without notice or without incurring obligations. All Rights reserved.



# Submittal-Charmo 24K Minisplit

Job name:		Submitted by:	
Location:		Submitted to:	
Engineer:		Unit tag:	
Date:		Drawing number:	

## Warranty information

Standard 7 years parts & compressor  
 Registered 12 years parts & compressor  
 Terms and conditions apply

## Type

Energy Star Heat Pump

Cold Climate Energy Star Heat Pump

## Model numbers

Indoor: KW24HQ19CDI

Outdoor: KW24HQ19CDO

## Capacity range

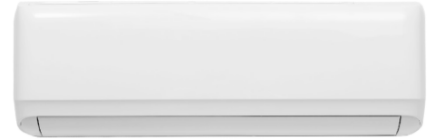

R32



20 Inverter

AHRI

Output (BTU/H)	Minimum	Rated	Max	Certification		
Cooling:	5800	24000	26270	AHRI NO.	Energy Star	nep
Heating:	5400	24000	26600	217995506	4,515,403.	
Heating performance				Efficiency Ratings		
Output (BTU/H)	Minimum	Rated	Max	SEER2	19	
47F (8.3C)	5800	22400	24000	HSPF2	8.5	
17F (-8.3C)	5800	19200	19300	EER (W/W)	3.5	
5F (-15C)	3400	16800	16800	COP (W/W)	3.6	
Outdoor temperature range				Electrical		
Cooling:	-18-48C	0-118F		Power supply	208-230V/60Hz/1Ph	
Heating:	-25-24C	-13-75F		Min/Max voltage	187-253Vac	
Condenser specifications				MCA	15A	
Connecting type		Screw Connection		MOP	20A	
Liquid line size		1/4in (6mm)		Power Supply Wire	12/3 AWG	
Gas line size		1/2in (12mm)		Interconnecting Wire	14/4 AWG	
pre-charge length		24.6ft (7.5M)		Features:		
MIN. Refrigerant Pipe Length		10 ft (3M)		Capillary Expansion		
MAX. Refrigerant Pipe Length		131ft (40M)		Rotary compressor		
MAX. Vertical Height difference (total)		82 ft (25M)		Basepan heater		
Refrigerant Type		R-32		Compressor electric heater		
Factory Charge		42.3 oz		Weight		
Additional Charge		0.2 oz/ft		Gross weight:	103.6 Lbs (47Kg)	
Sound Pressure Level		58 dB (A)		Net weight:	93.7 Lbs (42.5Kg)	

Specifications are subject to change without notice. Manufacturer reserves the right to discontinue or modify specifications or designs without notice or without incurring obligations. All Rights reserved.



# Outdoor unit Dimensions

KW24HQ19CDO

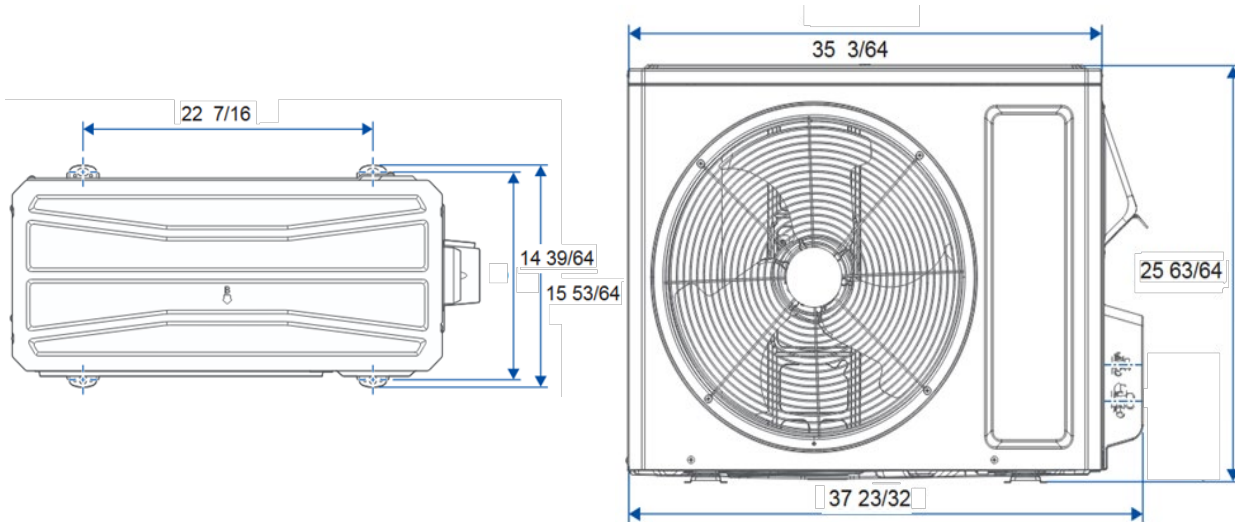

## Minimum outdoor unit clearances

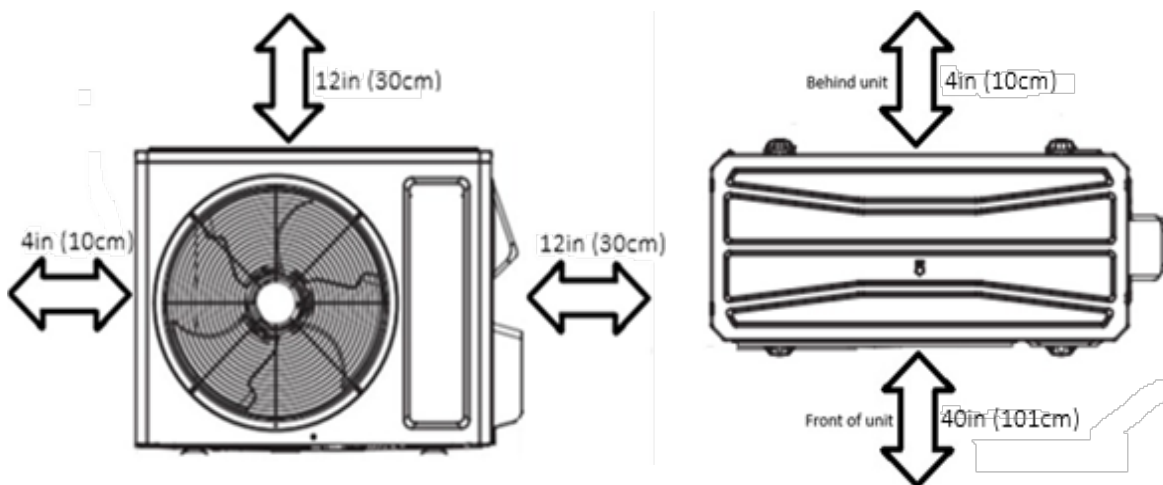

Unit must be placed a minimum 18in (45cm) above any surfaces to allow for snow clearance and defrost runoff.

Please follow local best practices and guidelines.

Specifications are subject to change without notice. Manufacturer reserves the right to discontinue or modify specifications or designs without notice or without incurring obligations. All Rights reserved.



# Indoor unit specifications

KW24HQ19CDI

Air flow volume			dB (A)
Turbo	677 CFM	1150 m3/h	51
High	589 CFM	1000 m3/h	47
Med-high	559 CFM	950 m3/h	44
Medium	500 CFM	850 m3/h	41
Med-low	471 CFM	800 m3/h	40
Low	441 CFM	750 m3/h	38
Sleep	412 CFM	700 m3/h	36

Net weight:	33.1 Lbs	Gross weight:	39.7 Lbs
	15 Kg		18 Kg
Included:	Infrared remote YBE1FBB		
Dehumidification level:	5.28 pt/hr		
<b>Optional Accessories</b>			
24V interlock wired controller:	XE71-00/E		
Wired controller:	XE71-44G		
Embedded wired controller:	XE74-44E		
Embedded WIFI wired controller:	XE72-44E		

### Included Features

WI-FI control	8C heating	I-feel	Self clean	Forced defrost	Soft start	Low voltage startup
---------------	------------	--------	------------	----------------	------------	---------------------

### Indoor unit Dimensions

Unit: inch

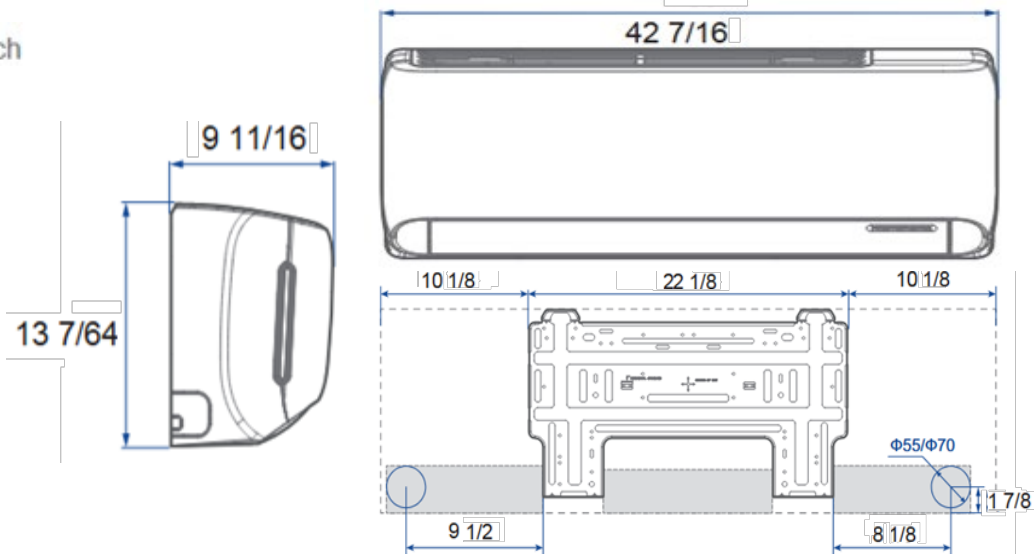

### Minimum indoor unit clearances

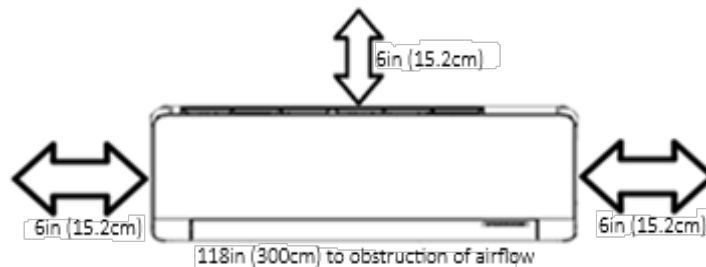

Specifications are subject to change without notice. Manufacturer reserves the right to discontinue or modify specifications or designs without notice or without incurring obligations. All Rights reserved.



# Submittal-Charmo 30K Minisplit

Job name:		Submitted by:	
Location:		Submitted to:	
Engineer:		Unit tag:	
Date:		Drawing number:	

## Warranty information

Standard 7 years parts & compressor  
 Registered 12 years parts & compressor  
 Terms and conditions apply

## Type

Energy Star Heat Pump

Cold Climate Energy Star Heat Pump

## Model numbers

Indoor: KW30XQ21CDI

Outdoor: KW30XQ21CDO

## Capacity range



R32



20 Inverter

AHRI

Output (BTU/H)	Minimum	Rated	Max	Certification		
Cooling:	3000	30000	36000	AHRI NO.	Energy Star	nep
Heating:	5800	30000	35500	216772294	4,514,290.	
Heating performance				Efficiency Ratings		
Output (BTU/H)	Minimum	Rated	Max	SEER2	22	
47F (8.3C)	9100	30000	32000	HSPF2	9	
17F (-8.3C)	8500	24000	27000	EER (W/W)	3.2	
5F (-15C)	7500	23000	23000	COP (W/W)	3.2	
Outdoor temperature range				Electrical		
Cooling:	-20-50C	-4-122F		Power supply	208-230V/60Hz/1Ph	
Heating:	-25-24C	-13-75F		Min/Max voltage	187-253Vac	
Condenser specifications				MCA	27A	
Connecting type		Screw Connection		MOP	30A	
Liquid line size		1/4in (6mm)		Power Supply Wire	10/3 AWG	
Gas line size		5/8in (16mm)		Interconnecting Wire	14/4 AWG	
pre-charge length		24.6ft (7.5M)		Features:		
MIN. Refrigerant Pipe Length		10 ft (3M)		Electronic Expansion Valve		
MAX. Refrigerant Pipe Length		131ft (40M)		Rotary compressor		
MAX. Vertical Height difference (total)		82 ft (25M)		Basepan heater		
Refrigerant Type		R-32		Compressor electric heater		
Factory Charge		56.4 oz		Weight		
Additional Charge		0.2 oz/ft		Gross weight:	127.9 Lbs (58Kg)	
Sound Pressure Level		62 dB (A)		Net weight:	116.8 Lbs (53Kg)	

Specifications are subject to change without notice. Manufacturer reserves the right to discontinue or modify specifications or designs without notice or without incurring obligations. All Rights reserved.



# Outdoor unit Dimensions

KW30XQ21CDO

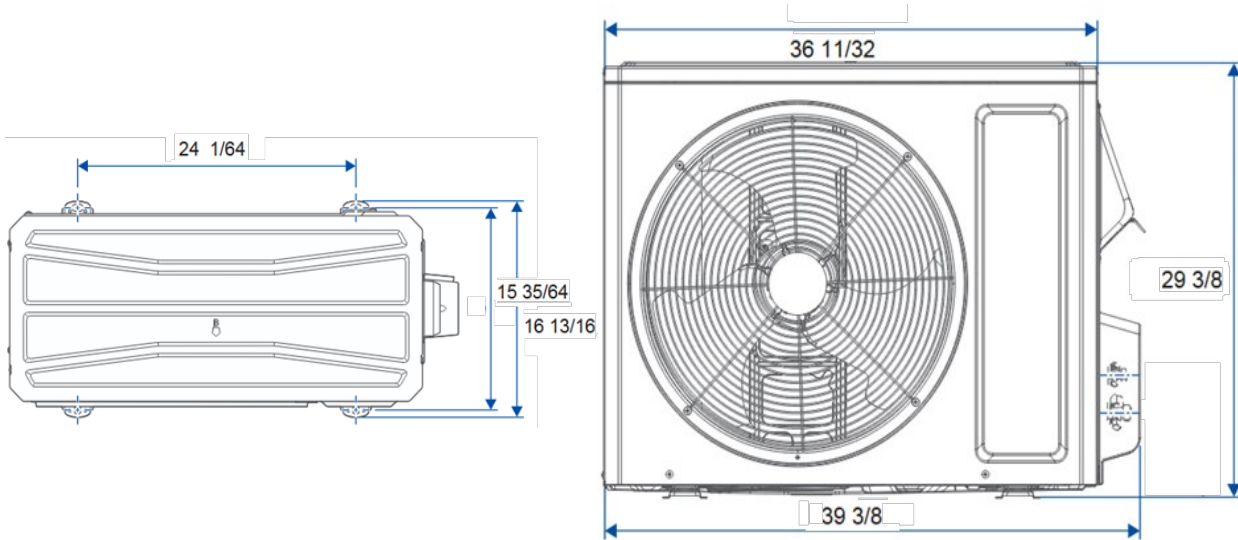

## Minimum outdoor unit clearances

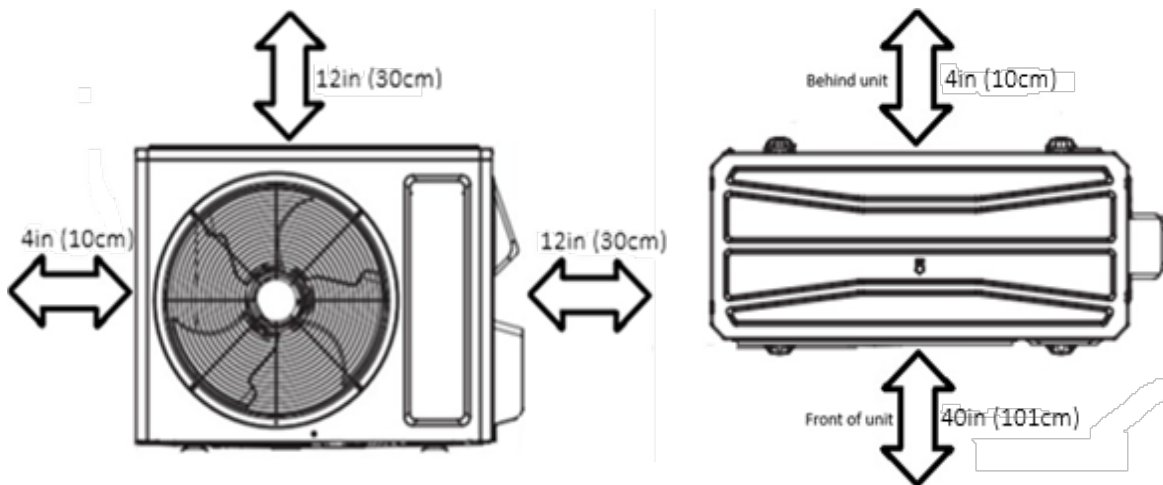

Unit must be placed a minimum 18in (45cm) above any surfaces to allow for snow clearance and defrost runoff.

Please follow local best practices and guidelines.

Specifications are subject to change without notice. Manufacturer reserves the right to discontinue or modify specifications or designs without notice or without incurring obligations. All Rights reserved.



# Indoor unit specifications

KW30XQ21CDI

Air flow volume			dB (A)
Turbo	794 CFM	1350 m3/h	52
High	647 CFM	1100 m3/h	45
Med-high	618 CFM	1050 m3/h	44
Medium	559 CFM	950 m3/h	41
Med-low	500 CFM	850 m3/h	39
Low	471 CFM	800 m3/h	38
Sleep	441 CFM	750 m3/h	36

Net weight:	33.1 Lbs	Gross weight:	39.7 Lbs
	15 Kg		18 Kg
Included:	Infrared remote YBE1FBB		
Dehumidification level:	7.4 pt/hr		
<b>Optional Accessories</b>			
24V interlock wired controller:	XE71-00/E		
Wired controller:	XE71-44G		
Embedded wired controller:	XE74-44E		
Embedded WIFI wired controller	XE72-44E		

### Included Features

WI-FI control	8C heating	I-feel	Self clean	Forced defrost	Soft start	Low voltage startup
---------------	------------	--------	------------	----------------	------------	---------------------

### Indoor unit Dimensions

Unit: inch

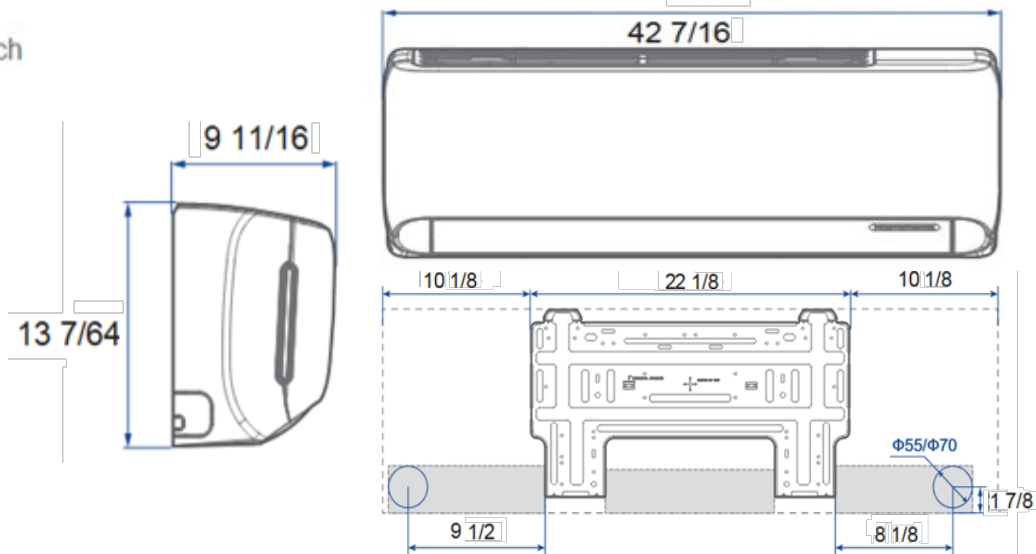

### Minimum indoor unit clearances

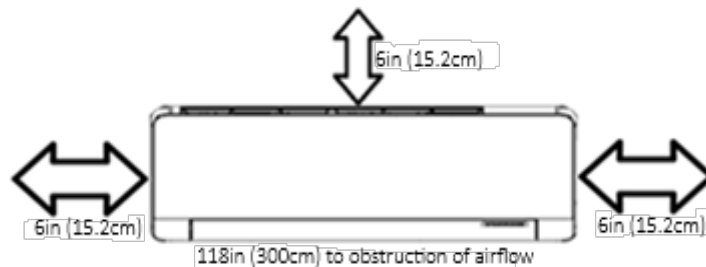

Specifications are subject to change without notice. Manufacturer reserves the right to discontinue or modify specifications or designs without notice or without incurring obligations. All Rights reserved.



# Submittal-Charmo 36K Minisplit

Job name:		Submitted by:	
Location:		Submitted to:	
Engineer:		Unit tag:	
Date:		Drawing number:	

## Warranty information

Standard 7 years parts & compressor  
 Registered 12 years parts & compressor  
 Terms and conditions apply

## Type

Energy Star Heat Pump

Cold Climate Energy Star Heat Pump

## Model numbers

Indoor: KW36XQ21CDI

Outdoor: KW36XQ21CDO

## Capacity range



R32



20 Inverter

AHRI

Output (BTU/H)	Minimum	Rated	Max	Certification		
Cooling:	7850	33600	37500	AHRI NO.	Energy Star	nep
Heating:	10000	34000	37500	216772293	3,995,738.	
Heating performance				Efficiency Ratings		
Output (BTU/H)	Minimum	Rated	Max	SEER2	21	
47F (8.3C)	10000	34000	34100	HSPF2	8.5	
17F (-8.3C)	9000	27400	27500	EER (W/W)	3.2	
5F (-15C)	9000	24600	24600	COP (W/W)	3.2	
Outdoor temperature range			Electrical			
Cooling:	-20-50C	-4-122F	Power supply	208-230V/60Hz/1Ph		
Heating:	-25-24C	-13-75F	Min/Max voltage	187-253Vac		
Condenser specifications			MCA	24A		
Connecting type	Screw Connection		MOP	30A		
Liquid line size	1/4in (6mm)		Power Supply Wire	10/3 AWG		
Gas line size	5/8in (16mm)		Interconnecting Wire	14/4 AWG		
pre-charge length	24.6ft (7.5M)		Features:			
MIN. Refrigerant Pipe Length	10 ft (3M)		Electronic Expansion Valve			
MAX. Refrigerant Pipe Length	131ft (40M)		Rotary compressor			
MAX. Vertical Height difference (total)	82 ft (25M)		Basepan heater			
Refrigerant Type	R-32		Compressor electric heater			
Factory Charge	56.4 oz		Weight			
Additional Charge	0.2 oz/ft		Gross weight:	127.9 Lbs (58Kg)		
Sound Pressure Level	62 dB (A)		Net weight:	116.8 Lbs (53Kg)		

Specifications are subject to change without notice. Manufacturer reserves the right to discontinue or modify specifications or designs without notice or without incurring obligations. All Rights reserved.



# Outdoor unit Dimensions

KW36XQ21CDO

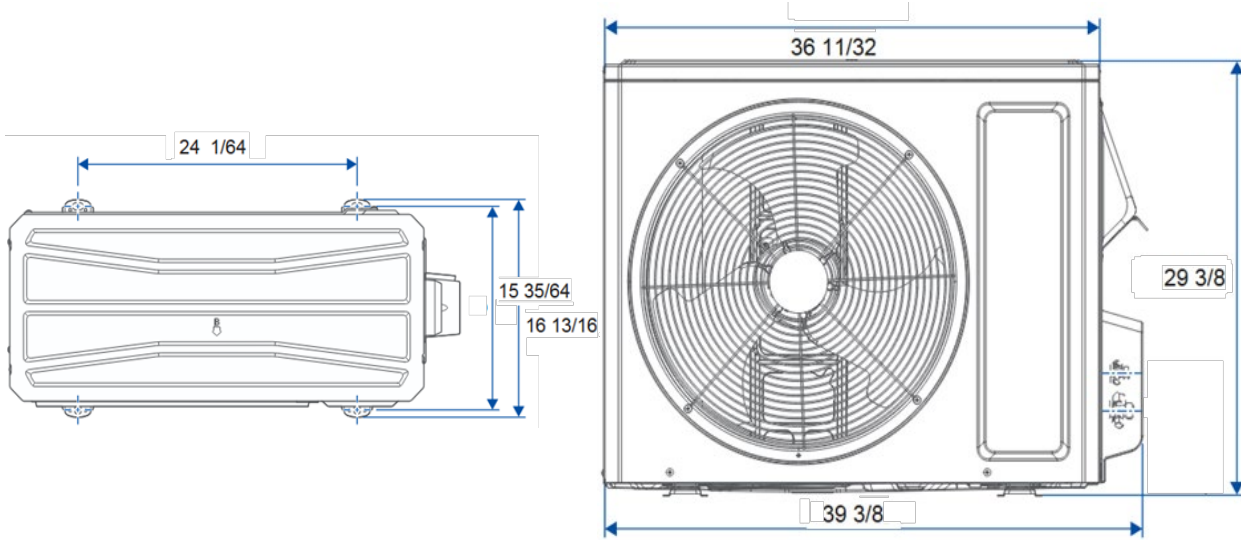

## Minimum outdoor unit clearances

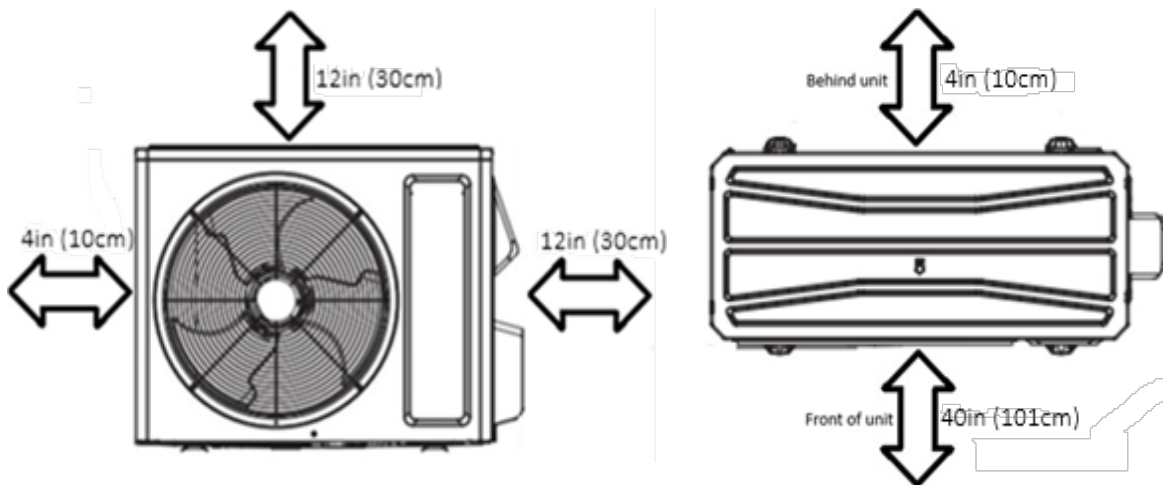

Unit must be placed a minimum 18in (45cm) above any surfaces to allow for snow clearance and defrost runoff.

Please follow local best practices and guidelines.

Specifications are subject to change without notice. Manufacturer reserves the right to discontinue or modify specifications or designs without notice or without incurring obligations. All Rights reserved.



# Indoor unit specifications

KW36XQ21CDI

Air flow volume			dB (A)
Turbo	794 CFM	1350 m3/h	52
High	647 CFM	1100 m3/h	45
Med-high	618 CFM	1050 m3/h	44
Medium	559 CFM	950 m3/h	41
Med-low	500 CFM	850 m3/h	39
Low	471 CFM	800 m3/h	38
Sleep	441 CFM	750 m3/h	36

Net weight:	33.1 Lbs	Gross weight:	39.7 Lbs
	15 Kg		18 Kg
Included:	Infrared remote YBE1FBB		
Dehumidification level:	7.4 pt/hr		
<b>Optional Accessories</b>			
24V interlock wired controller:	XE71-00/E		
Wired controller:	XE71-44G		
Embedded wired controller:	XE74-44E		
Embedded WIFI wired controller	XE72-44E		

### Included Features

WI-FI control	8C heating	I-feel	Self clean	Forced defrost	Soft start	Low voltage startup
---------------	------------	--------	------------	----------------	------------	---------------------

### Indoor unit Dimensions

Unit: inch

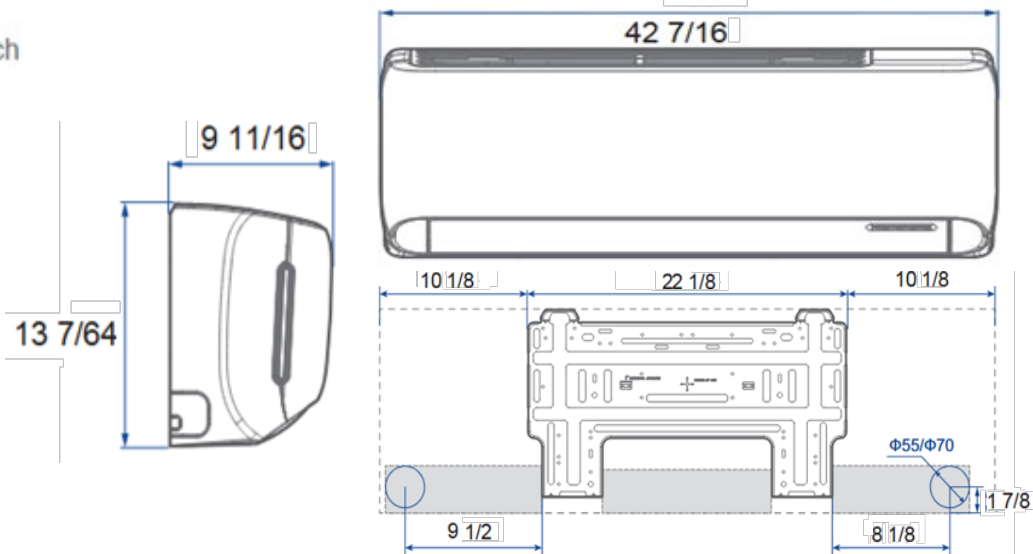

### Minimum indoor unit clearances

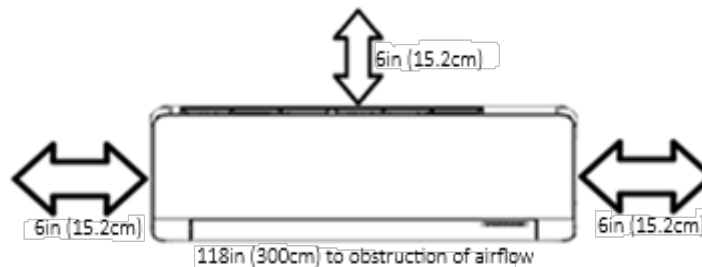

Specifications are subject to change without notice. Manufacturer reserves the right to discontinue or modify specifications or designs without notice or without incurring obligations. All Rights reserved.