



ENGINEERING-PDH.com
ONLINE CONTINUING EDUCATION

PAVING EQUIPMENT BASICS & SAFETY

Main Category:	Civil Engineering
Sub Category:	-
Course #:	CIV-121
Course Content:	52 pgs
PDH/CE Hours:	4

OFFICIAL COURSE/EXAM
(SEE INSTRUCTIONS ON NEXT PAGE)

WWW.ENGINEERING-PDH.COM

TOLL FREE (US & CA): 1-833-ENGR-PDH (1-833-364-7734)

SUPPORT@ENGINEERING-PDH.COM

CIV-121 EXAM PREVIEW

- TAKE EXAM! -

Instructions:

- At your convenience and own pace, review the course material below. When ready, click “Take Exam!” above to complete the live graded exam. (Note it may take a few seconds for the link to pull up the exam.) You will be able to re-take the exam as many times as needed to pass.
- Upon a satisfactory completion of the course exam, which is a score of 70% or better, you will be provided with your course completion certificate. Be sure to download and print your certificates to keep for your records.

Exam Preview:

1. According to the reference material, the primed base should be adequately cured before the wearing surface is laid. In general, a minimum of 48 hours should be allowed for complete curing.
 - a. True
 - b. False
2. A hot-mixed or hot-load paving mixture is the best type of pavement; the aggregate and binder should be heated to approximately 310°F and laid no colder than ___°F.
 - a. 230
 - b. 250
 - c. 280
 - d. 300
3. Various types of trucks are used to deliver hot mix to the paver. The most common type is the ___-ton end-dump truck but other trucks have been used and can be used to deliver mix.
 - a. 5
 - b. 7
 - c. 10
 - d. 20
4. According to the reference material, the uniform application of asphalt prime and tack coat is essential. Transverse spread should not be allowed to vary more than 10 percent, and the longitudinal spread should not vary more than 15 percent.
 - a. True
 - b. False

5. Using Figure 16-28.-Sequence of operations for the application of a single-surface treatment and the surrounding reference material which of the following operations follows directly behind the priming application?
 - a. Rolling
 - b. Aggregate application
 - c. Binder application
 - d. Sweeping
6. According to the reference material, road oiling consists of spraying an untreated surface with a low-viscosity liquid asphalt, such as SC-70, MC-30, MC-70, or a diluted slow-setting asphalt emulsion.
 - a. True
 - b. False
7. Cracking takes many forms. To make the proper repairs, first you should determine the type of crack and the cause. Which of the following type of crack is normally caused by alternate wetting and drying beneath the shoulder surface?
 - a. Alligator cracks
 - b. Edge cracks
 - c. Edge joint cracks
 - d. Lane joint cracks
8. Using Table 16-3.-Suggested Spraying Temperature Ranges for Prime and Tack Coat, what is the correct temperature range for spraying a MC-30 grade asphalt?
 - a. 70-160°F
 - b. 85°F+
 - c. 120°F+
 - d. 165°F+
9. Pavement distortion is any change in a flexible pavement surface. Which of the following type of pavement distortion matches the description: the progressive loss of surface material by weathering or traffic abrasion?
 - a. Depressions
 - b. Channeling
 - c. Potholes
 - d. Raveling
10. According to the reference material, the most important phase of flexible pavement construction is compaction. When the specified density of asphalt pavement mix is not obtained during construction, subsequent traffic will further consolidate the pavement.
 - a. True
 - b. False

PAVING OPERATIONS AND EQUIPMENT

BASICS & SAFETY

The modern use of asphalt for road and street construction began in the late 1800s and grew rapidly with the emerging automobile industry. Today, asphalt technology is complex, and the equipment and techniques, used to build asphalt pavement structures, are highly sophisticated. This chapter presents only the basic components, procedures, and principles of paving operations. The extensive knowledge and skills, required to perform the operations, must be gained through formal training and on-the-job-training experience.

NOTE: One rule that has remained constant throughout the long history of the use of asphalt in construction is this: a pavement is only as good as the materials and workmanship that go into it. No amount of sophisticated equipment can make up for the use of poor materials or poor construction practices.

PAVEMENT CONSTRUCTION

Modern paving is broadly divided into **rigid paving** and **flexible paving**. Both types consist of an aggregate blend (sand, gravel, crushed stone, etc.), bound together by a hardening or setting agent, called a **binder**. The primary difference between the two types of paving, from the standpoint of ingredients used, lies in the character of the binder.

The binder for most rigid paving is **portland cement**, and for this reason, rigid paving is often referred to as **concrete paving**. In flexible paving, the binder consists of bituminous material. Paving mixes, containing bituminous material, are referred to as **asphalt-paving mixes**.

ASPHALT-PAVING MIXES

Asphalt-paving mixes may be produced from a wide range of aggregate combinations, with each combination having its own characteristics and being suited to specific design and construction uses. Aside from the asphalt content, the principal characteristics of the mix are determined by the relative amounts of aggregates. The aggregate composition may vary from a coarse-textured mix to a fine-textured mix, depending on aggregate size and design specifications.

The selection of bituminous material depends upon the type of pavement, temperature extreme, rainfall, type and volume of traffic, and type and availability of equipment. In general, hard penetration grades of asphalt paving are used in warm climates and softer penetration grades in cold climates. Heavier grades of asphalt cutbacks and tars are generally used in warm regions.

Asphalt materials are produced by the refining of petroleum (fig. 16-1). Asphalt is produced in a variety of types and grades, ranging from hard, brittle solids to almost water-thin liquids. The semisolid form, known as **asphalt cement**, is the basic material.

Liquid asphaltic products are generally prepared by cutting back (blending) asphalt cements with petroleum distillates or by blending with an emulsified agent and water known as *asphalt emulsion*. Types of liquid asphaltic products are shown in figure 16-2.

Table 16-1 indicates various uses of asphalt for different types of construction.

BASIC CONCEPTS

The basic idea in building roads, airfields, or parking areas for all-weather use by vehicles is to prepare a suitable foundation, to provide necessary drainage, and to construct a pavement that has the following characteristics:

1. Has sufficient total thickness and internal strength to carry expected traffic loads.
2. Is capable of preventing both the penetration and accumulation of moisture.
3. Has a top surface that is smooth and skid resistant.
4. Is resistant to wear and distortion.
5. Is resistant to deterioration caused by weather conditions or by deicing chemicals.

The foundation ultimately carries all traffic loads. Therefore, the structural function of pavement is to support a wheel load on the pavement surface and to transfer and spread that load to the foundation without

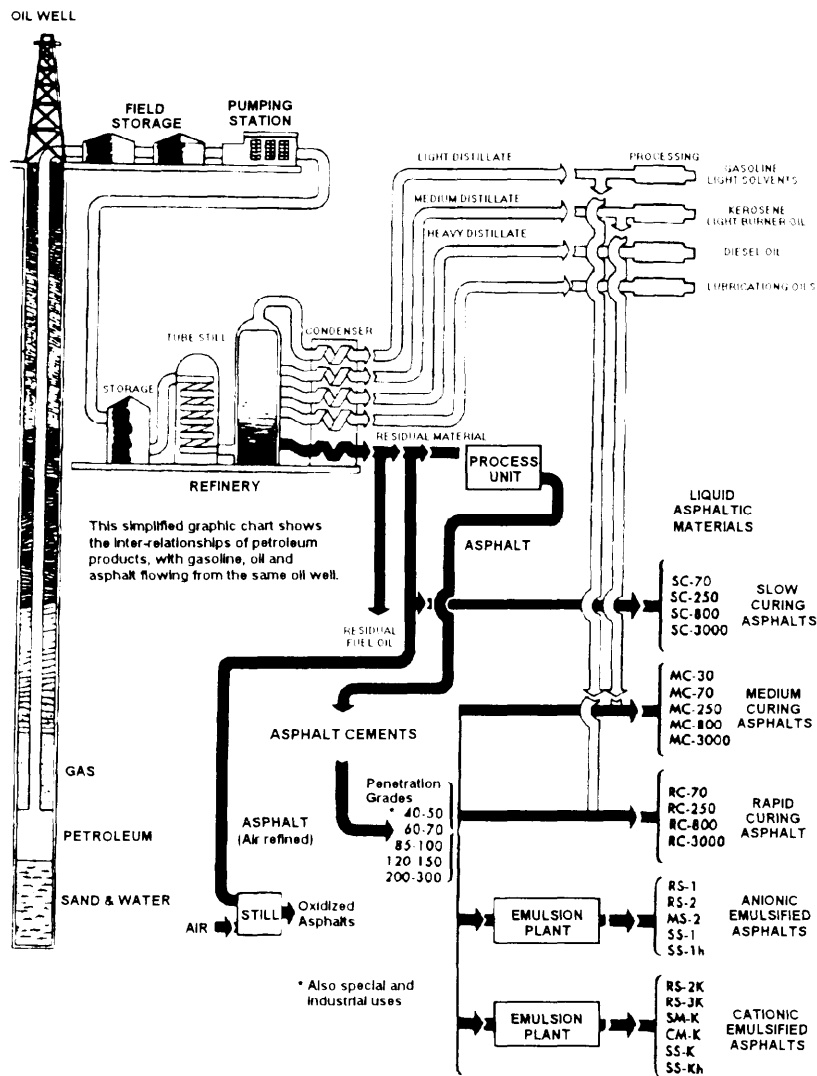

Figure 16-1.—Petroleum asphalt flow chart.

GASOLINE OR NAPHTHA	KEROSENE OR JET FUEL (JP-4)	RESIDUAL OR DIESEL SLOWLY VOLATILE & NON-VOLATILE OILS	WATER AND EMULSIFIER	WATER AND EMULSIFIER
ASPHALT CEMENT	ASPHALT CEMENT	ASPHALT CEMENT	ASPHALT CEMENT	RC, MC or SC LIQUID ASPHALT
RAPID CURING (RC)	MEDIUM CURING (MC)	SLOW CURING (SC)	ASPHALT EMULSIONS	INVERTED EMULSIFIED ASPHALT
— CUTBACKS —		ROAD OILS		

NOTE: These diagrams are not proportional to composition

Figure 16-2.-Liquid asphaltic products.

overloading either the strength of the subgrade or the internal strength of the pavement itself.

Figure 16-3 shows the wheel load (W) being transmitted to the pavement surface through the tire at an approximately uniform vertical pressure (P_{405}). The pavement then spreads the wheel load to the foundation, so the maximum pressure on the foundation is only P_{415} . By proper selection of pavement materials and with adequate pavement thickness, P_{415} will be small enough to be easily supported by the subgrade.

ASPHALT PAVEMENT STRUCTURE

Asphalt pavement is a general term applied to any pavement that has a surface, constructed with asphalt (fig. 16-4). Normally, it consists of a surface course (layer) of mineral aggregate, coated and cemented with

Table 16-1.—Recommended Uses of Various Asphalt Grades

TYPE OF CONSTRUCTION	PAVING ASPHALTS				LIQUID ASPHALTS																	
	40-50	60-70	85-100	170-150	Rapid Curing (RC)			Medium Curing (MC)			Slow Curing (SC)			Emulsified								
					70	250	800	30	70	250	800	3000	70	250	800	3000	Anionic			Cationic		
																	RS-1	RS-2	MS-2	SS-1	SS-1H	RS-2K
ASPHALT CONCRETE AND PLANT MIX, HOT LAID																						
Highways.....	x	x	x																			
Airports.....	x	x																				
Parking Areas.....	x	x																				
Driveways.....	x	x																				
Curbs.....	x	x																				
Industrial Floors.....	x																					
Blocks.....	x																					
PLANT MIX, COLD LAID																						
Graded Aggregate																						
ROAD MIX																						
Open graded Aggregate.....						x	x															
Dense graded Aggregate.....						x	x															
Clean Sand.....																						
Sandy Soil.....																						
PENETRATION MACADAM																						
Large Voids.....																						
Small Voids.....																						
SURFACE TREATMENTS																						
Single, Multiple and Aggregate Seal.....						x	x															
Sand Seal.....																						
Slurry Seal.....																						
Fog Seal.....																						
Prime Coat, open surfaces.....																						
Prime Coat, tight surfaces.....																						
Tack Coat.....																						
Dust Laying.....																						
PATCHING MIX																						
Immediate Use.....																						
Stock Pile.....																						
HYDRAULIC STRUCTURES																						
Membrane Linings, Canals & Reservoirs.....																						
Hot Laid, Graded Aggregate Mix for Groins, Dam Facings, Canal & Reservoir Linings.....																						
CRACK FILLING																						
Membrane Envelope.....																						
Expansion Joints.....																						
Undersealing PCC.....																						
Roofing.....																						
Miscellaneous.....																						

In northern areas where rate of curing is slower, a shift from MC to RC or from SC to MC may be desirable. For very warm climates, a shift to next heavier grade may be warranted.
 1 In combination with powdered asphalt.
 2 Diluted with water.
 3 Also 50-60 penetration blown asphalt and prefabricated panels.
 4 Slurry mix.

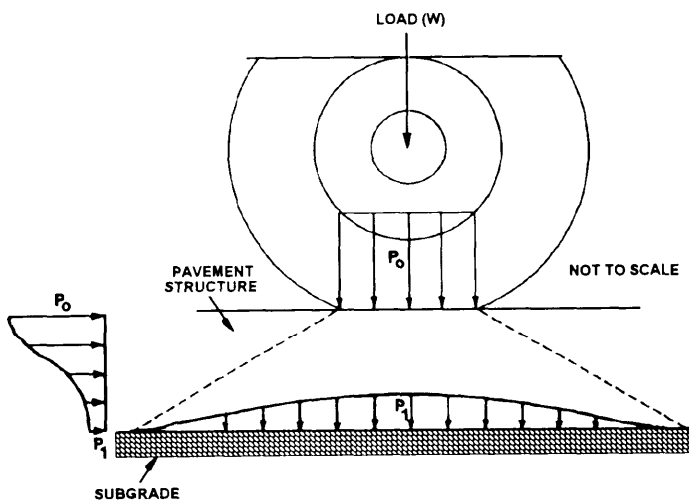

Figure 16-3.—Spread of wheel load through the pavement structure.

asphalt, and one or more supporting courses, which may be of the following types:

1. Asphalt base, consisting of asphalt-aggregate mixtures (macadam)

2. Crushed stone (rock), slag, or gravel
3. Portland cement concrete
4. Old brick or stone block pavements

Asphalt pavement structure consists of all courses above the prepared foundation. The upper or top layer is the asphalt-wearing surface.

Essential Properties of Asphalt-Wearing Surface

The surface of an asphalt pavement, exposed to vehicular traffic, must be tough to resist distortion and to provide a smooth riding surface. It must be waterproof and sloped to shed surface water to the roadside and protect the entire asphalt pavement structure and the foundation from the erosive effects of moisture. It must resist wear, caused by traffic, and still retain necessary anti-skid properties. It must also be bonded to the layer or course beneath it.

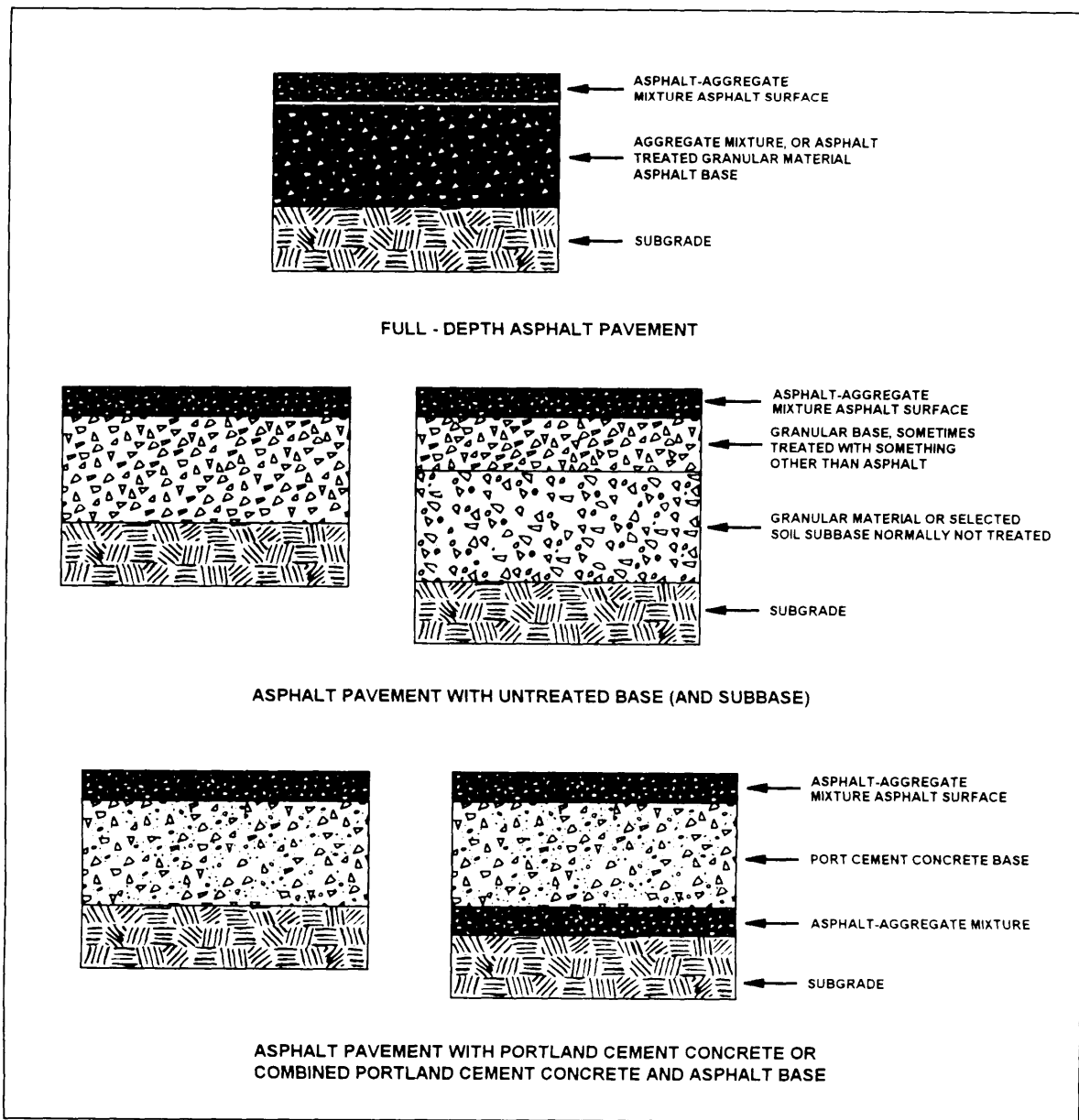

Figure 16-4. Asphalt pavement cross sections, showing common and typical asphalt pavement structures.

Function of Base Course and Subgrade

The base course and subgrade are structural elements of the pavement. In conjunction with the overlying asphalt surface, their purpose is to distribute traffic wheel loads over the whole foundation (fig. 16-4). To perform this function, you build the base course and subgrade with the necessary internal strength properties. In this respect, full-depth asphalt pavements have a special advantage over pavements with granular bases.

Asphalt pavement layers have both tensile and compressive strength to resist internal stresses. For

example, figure 16-5 shows how wheel load (W) slightly deflects the pavement structure, causing both tensile and compressive stresses within the pavement. Untreated granular bases have no tensile strength; therefore, asphalt bases spread the wheel load over broader areas than untreated granular bases. The result of this is that less total pavement structure thickness is required for an asphalt base.

Determining Required Pavement Thickness

A significant advance in highway engineering is the realization and demonstration that structural design of

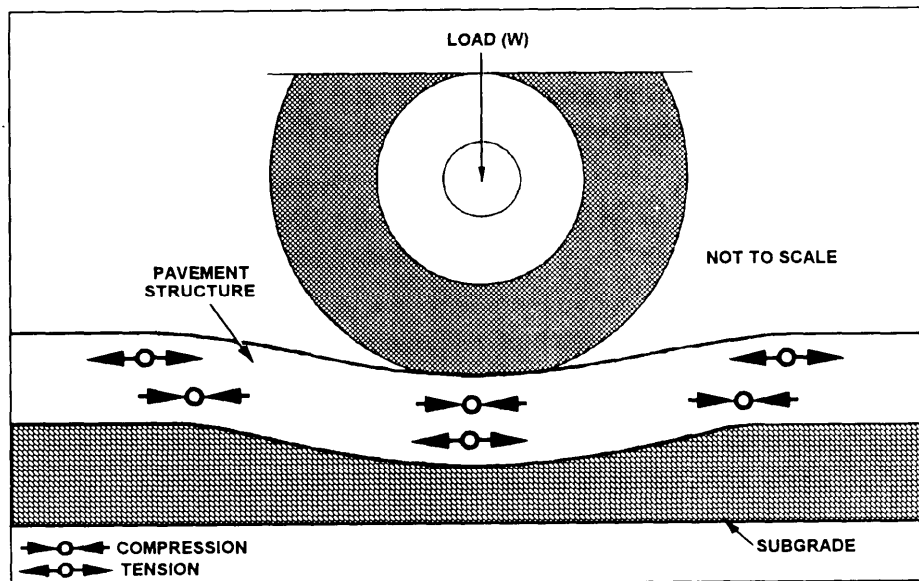

Figure 16-5.—Pavement deflection results in tensile and compressive stresses in pavement structure.

asphalt pavements is similar to the problem of designing any other complex engineering structure. When asphalt pavement was first being introduced, determining the proper thickness was a matter of guesswork, rule of thumb, and opinion, based on experience. Almost the same situation once prevailed in determining the dimensions of masonry arches and iron and steel structures. However, these early techniques have long since yielded to engineering analysis. Similarly, based on comprehensive analysis of vast volumes of accumulated data, the structural design of asphalt pavements has now been developed into a reliable engineering procedure.

There is no standard thickness for a pavement. Required total thickness is determined by engineering design procedure. Factors considered in the procedure are as follows:

1. Traffic to be served initially and over the design service life of the pavement
2. Strength and other pertinent properties of the prepared subgrade
3. Strength and other influencing characteristics of the materials available or chosen for the layers (or courses) in the total asphalt pavement structure
4. Any special factors peculiar to the road being designed

Stage Construction

Because weight and traffic volume normally increase, pavement originally built thick enough to handle immediate traffic volumes may not be thick enough and strong enough to handle future needs. With asphalt pavement, this problem can be met economically by first building the thickness required, then adding, when needed, layers of asphalt to increase total pavement thickness. This procedure is called **stage construction**. It avoids excessive investment in the beginning; and when a new layer of asphalt is added, the wearing surface is equal to or better than the original.

Subgrade Evaluation

Several methods for evaluating or estimating the strength and supporting power of a subgrade are in use today, including the following:

1. Loading tests in the field on the subgrade itself. For example, the plate bearing test uses large, circular plates, loaded to produce critical amounts of deformation on the subgrade in place.
2. Loading tests in a laboratory using representative samples of the subgrade soil. A test commonly used by the Seabees is the California bearing ratio (CBR) test, which is sometimes used on the subgrade in place in the field.
3. Evaluations, based on classification of soil by identifying and testing the constituent particles of the soil.

Two well-known classification systems are the American Association of State Highway and Transportation Officials (AASHTO) Classification System and the Unified Soil Classification System, used by the Department of Defense.

PREPARING ASPHALT FOR CONSTRUCTION OPERATIONS

Paving grade asphalt (asphalt cement), which at normal atmospheric temperatures is semisolid and highly viscous, must be made temporarily fluid (liquefied) for handling during construction operations, such as pumping through pipes, transporting in tanks, spraying through nozzles, and mixing with aggregate. When pavement construction operations are finished, the asphalt cement reverts to its normal condition and functions as the cementing (or binding) and waterproofing agent that makes the pavement stable and durable.

Asphalt cement can be made temporarily fluid (liquefied) for construction operations in three ways:

1. By heating the asphalt. After construction operations, the hot liquid asphalt cement cools and changes from a fluid to its normal, semisolid condition.

2. By dissolving the asphalt in selected petroleum solvents. This process is called **cutting back**; the diluted asphalt is called **cutback asphalt**. After construction the solvent evaporates, leaving the asphalt cement in place.

NOTE: The use of cutback asphalt in the United States has declined because of the petroleum shortage and government environmental regulations. It is being superseded by emulsified asphalt, which contains little or no solvent, and can be used for almost any purpose that cutbacks can.

3. By emulsifying the asphalt with an emulsifying agent and water. While asphalt and water ordinarily do not mix, they can be made to mix by churning asphalt in a **colloid mill**. The resulting product, called **emulsified asphalt**, is a fluid and is ready for construction operations. During construction the water and asphalt separate. The asphalt particles merge into a continuous film that cements the aggregate particles together as the water evaporates. When the water and asphalt separate, it is said that the emulsion **breaks** or **sets**.

A hot-mixed or hot-load paving mixture is the best type of pavement; the aggregate and binder should be heated to approximately 310°F and laid no colder than

250°F. Determining the exact temperature(s) to use will depend upon the weather and the distance that the material is hauled. Some clues that indicate the condition of the asphalt are as follows:

- Overheated asphalt loses some of its binding qualities. Blue smoke, rising from the spreader hopper, is sometimes an indicator this condition exists.

- A generally stiff appearance and improper coating of aggregate indicates the mix is too cold.

- Material laying flat in the bed of the truck with a shiny appearance means the mix is too rich in asphalt cement.

- When it is too lean, the mix will look dry and dull.

Prime Coat

Priming consists of the initial treatment on a granular base before surfacing with a bituminous material or pavement. The purpose of a prime coat is to penetrate the base (about 1/4-inch minimum penetration is desired), fill most of the voids, promote adhesion between the base and the bituminous applications placed on top of it, and waterproof the base. Surfaces must be as clean as possible, and where and conditions exist (dried-out surfaces), a light fog spray with water should be considered before priming actually begins.

The priming material may be either a low-viscosity tar, a low-viscosity asphalt, or a diluted asphalt emulsion. The bituminous materials, used for the prime coat, should be applied in quantities known as **rate of application (ROA)** of not less than 0.2 gallon or more than 0.5 gallon per square yard. Normally, the construction project specifications denote the ROA for the prime coat application; however, when the ROA is not included in the project specifications, the NCF uses an ROA of .3 for planning purposes. When the base absorbs all of the prime material within 1 to 3 hours or when penetration is too shallow, the base is underprimed. Underpriming may be corrected by applying a second coating of the prime material.

An overprimed base may fail to cure or set and may contribute to failure of the pavement or bleed up through the asphalt mat. A free film of prime material remaining on the base after a 45-hour curing period indicates that the base is overprimed. This condition may be corrected by spreading a light, uniform layer of clean, dry sand over the prime coat to absorb the excess material. Application of the sand is usually followed by

light rolling and brooming. Excess prime, held in minor depressions, should be corrected by an application of clean, dry sand. Any loose sand should be lightly broomed from the primed surface before the wearing surface is laid.

The primed base should be adequately cured before the wearing surface is laid. In general, a minimum of 48 hours should be allowed for complete curing. Ordinarily, proper surface condition is indicated by a slight change in the shiny black appearance to a slightly brown color.

When a soil base is to be covered by a bituminous wearing surface, the area should be barricaded to prevent traffic from carrying dust or mud onto the surface both before and after priming. If it is necessary to open the primed base course to traffic before it has completely cured, a fine sand may be used; when you are ready to place the wearing surface, lightly broom the sand from the primed base course.

To estimate the amount of bitumen required for the prime coat, multiply the area to be treated by the rate of application (ROA).

NOTE: Under certain conditions, the estimate should include sufficient bitumen for an additional width of 1 foot on each side of the surface course to be constructed on the primed base.

The formula for a prime coat estimate is as follows:

For computing gallons:

Step 1:

$$\text{Gallons of Prime Coat Needed} = \frac{ROA \times L \times W}{9}$$

Step 2:

$$\begin{aligned} &\text{Gallons needed for waste} \\ &= \text{Gallons of prime coat} \times \text{WF (.05 or .10)} \end{aligned}$$

Step 3:

$$\begin{aligned} &\text{Total gallons required for the project:} \\ &= \text{Gallons of prime coat} + \text{waste gallons} \end{aligned}$$

Where

$$ROA = \text{rate of application of bitumen in gallons per square yard}$$

L = length of treated section in feet

W = width of treated surface in feet

9 = square feet per yard conversion factor

WF = Waste factor of bitumen = 5% at .05 or 10% at .10. This will depend on the experience of the asphalt distributor truck crew.

Example: the specification and other data for a prime coat application are as follows:

$$L = 3 \text{ miles} = 3 \times 5280 = 15840 \text{ feet}$$

$$W = 12 \text{ feet} + 1 \text{ foot on each side of the surface course to be constructed on the primed base}$$

$$ROA = 0.3 \text{ gal/sq yd}$$

$$WF = 5\% \text{ or } .05$$

Calculate the number of gallons of bitumen necessary to spray a tack coat.

Solution:

Step 1:

$$\text{Gallons} = \frac{.3 \times 15840 \times 14}{9} = \frac{66528}{9} = 7392 \text{ gallons}$$

Step 2:

$$\text{Waste} = 7392 \text{ gallons} \times \text{WF of } .05 = 369.6 \text{ gallons}$$

Step 3:

Total gallons required for the project:

$$369.6 \text{ gallons} + 7392 \text{ gallons} = 7761.6 \text{ gallons}$$

Always round your answer to the next higher number. In this case, 7761.6 is rounded to 7762 gallons.

Tack Coat

A tack coat is an application of asphalt to an existing paved surface to provide bond between the existing surface and the asphalt material to be placed on it. Two essential requirements of a tack coat areas follows: (1) it must be thin and (2) it must uniformly cover the entire surface to be treated. A thin tack coat does no harm to the pavement, and it will properly bond the course.

Some of the bituminous materials, used for tack coats, are rapid-curing cutbacks, road tar cutbacks, rapid-setting emulsions (may be used in warm weather), and medium-asphalt cements. Because rapid-curing

cutbacks are highly flammable, safety precautions must be carefully followed.

A tack coat should be applied only when the surface to be tacked is dry; and the atmospheric temperature has not been below 35°F for 12 hours immediately before application.

Before applying the tack coat to a surface that is sufficiently bonded, ensure that all loose material, dirt, clay, or other objectionable materials are removed from the surface to be treated. This operation may be accomplished with a power broom or blower, supplemented with hand brooms if necessary.

Immediately following the preparation of the surface, the bituminous material should be uniformly applied by means of a bituminous (asphalt) distributor at the spraying temperature specified. The amount of bitumen application, known as **rate of application (ROA)**, for a tack coat should be applied in quantities not less than 0.05 or more than 0.25 gallon per square yard. The exact quantity varies with the condition of the existing pavement being tack-coated. Normally, the construction project specification denotes the ROA for the tack coat application; however, when the ROA is not included in the project specifications, the NCF uses an ROA of .15 for planning and estimating purposes.

Following the application of bituminous material, the surface should be allowed to dry until it is in a proper condition of tackiness to receive the surface course; otherwise, the volatile substances may act as a lubricant and prevent bonding with the wearing surface. Clean, dry sand should be spread on all areas that show an excess of bitumen to blot up and cure the excess effectively. After excess bitumen is set, any loose sand should be lightly broomed from the primed surface before the wearing surface is laid.

An existing surface that is to be covered by a bituminous wearing surface should be barricaded to prevent traffic from carrying dust or mud onto the surface, either before or after the tack coat is applied. Should it become necessary for traffic to use the surface, one lane may be tack-coated and paved, using the other lane as a traffic bypass. The bypass lane should be primed and sanded before it is opened to traffic and it should be swept and reprimed after the adjacent lane is completed. Doing this preserves the base and acts as a dust palliative (shelter.)

The formula for a tack coat estimate is as follows:

For computing gallons:

Step 1:

$$\text{Gallons of Tack Coat Needed} = \frac{ROA \times L \times W}{9}$$

Step 2:

$$\begin{aligned} &\text{Gallons needed for waste} \\ &= \text{Gallons of tack coat} \times WF (.05 \text{ or } .10) \end{aligned}$$

Step 3:

$$\begin{aligned} &\text{Total gallons required for the project:} \\ &= \text{Gallons of tack coat} + \text{waste gallons} \end{aligned}$$

Where

ROA = rate of application of bitumen in gallons per square yard

L = length of treated section in feet

W = width of treated surface in feet

9 = square feet per yard conversion factor

WF = Waste Factor of bitumen = 5% at .05 or 10% at .10. This will depend on the experience of the asphalt distributor truck crew.

Example: The specification and other data for a tack coat application are as follows:

$$L = 2 \text{ miles} = 2 \times 5280 = 10560 \text{ feet}$$

$$W = 12 \text{ feet}$$

$$ROA = 0.5 \text{ gal/sq yd}$$

$$WF = 5\% \text{ or } .05$$

Calculate the number of gallons of bitumen necessary to spray a tack coat.

Solution:

Step 1:

$$\text{Gallons} = \frac{.05 \times 10560 \times 24}{9} = \frac{12672}{9} = 1408 \text{ gallons}$$

Step 2:

$$\text{Waste} = 1408 \text{ gallons} \times WF \text{ of } .05 = 70.4 \text{ gallons}$$

Step 3:

Total gallons required for the project:

$$70.4 \text{ gallons} + 1408 \text{ gallons} = 1478.4 \text{ gallons}$$

Always round your answer to the next higher number. In this case, 1478.4 is rounded to 1479 gallons.

TYPES OF ASPHALT PAVEMENT CONSTRUCTION

Two major types of asphalt pavement construction are in use today: **plant mix construction** (so-called because the mixture is prepared in a central mixing plant) and **mixed-in-place construction** (so-called because the mixture is mixed on the area to be paved).

PLANT MIX CONSTRUCTION

Asphalt-paving mixtures, prepared in a asphalt mixing plant, are known as **plant mixes**. Plant mix asphalt concrete is considered the highest quality plant mix. It consists of well-graded, high-quality aggregate and asphalt cement. The asphalt and aggregate are heated separately from 250°F to 325°F, carefully measured and proportioned, then mixed until the aggregate particles are coated with asphalt. The hot mixture, kept hot during transit, is hauled to the construction site where it is spread on the roadway with an asphalt-paving machine. The smooth layer from the paver is compacted by rollers to proper density before the asphalt cools.

Asphalt concrete is but one of a variety of hot-asphalt plant mixes. Other mixes, such as sand asphalt and coarse-graded mixes, are prepared and placed in a similar manner; however, each has one common ingredient, which is asphalt cement.

Asphalt mixes, containing emulsified or cutback asphalt, may also be prepared in asphalt mixing plants. The aggregate may be partially dried and heated or mixed as it is withdrawn from the stockpile. These mixes are usually referred to as **cold mixes**, even though heated aggregate may have been used in the mixing process.

Both asphalt mixtures, made with emulsified asphalt and some cutback asphalts, can be spread and compacted on the roadway while quite cool. Such mixtures are called **cold-laid asphalt plant mixes**. They are hauled and placed in normal warm weather temperatures. These mixtures, after being placed on the roadway, are sometimes processed or worked back and

forth laterally with a grader before being spread and compacted. This action speeds up setting or curing.

Compute Plant-Mix Materials

Several methods are used to calculate the amount of hot-mix material, required for paving projects; however, when the weight of a hot mix per square yard or cubic foot is not known, two equations are used in the NCF to compute the number of tons of asphalt, required for a project. These equations are as follows:

Equation 1

$$\text{Tons of Asphalt} = \frac{L \times W \times D \times 146}{2,000} = \text{Tons} \times (WF)$$

$$= \text{Percent of Tons} + \text{Tons} = \text{Tons Required}$$

L = length of project in feet.

W = width of project in feet.

D = depth or thickness of compacted mat. You must change inches into feet by dividing the number of inches by 12 (inches in 1 foot). For paver screed height, add 1/8 inch for each inch of the mat to be paved. (Example: For a 2-inch mat, two blocks of wood 2 1/4 inches thick will be required to set under the screed.) The blocks must be thicker than the finished compacted mat to allow for additional compaction by rollers.

146 = This number represents the approximate weight of 1 cubic foot of compacted hot-mix asphalt. This number can vary from 140 to 160 pounds; however, 146 pounds equals the 110 pounds per square yard per 1-inch depth of asphalt used in the second equation for figuring tons required for asphalt. (See table 16-2.)

WF = Waste factor equals 5% or .05, or 10% or .10, depending on the experience of the screed operators and handwork required on the project.

2,000 = 2,000 pounds is equal to one ton; therefore, you must divide the total weight of material by 2,000, giving tons required.

Equation 2

$$\text{Tons of Asphalt} = \frac{L \times W}{9} = \text{Square Yards} \times \frac{110 \text{ Pounds Per 1" Mat}}{2,000}$$

$$= \text{Tons} \times WF = \text{Percent of Tons} + \text{Tons} = \text{Tons Required}$$

Table 16-2.-Weight and Volume Relations for Various Types of Compacted Asphalt Pavement

Note: Because of the considerable variations of specific gravity, gradation, and other characteristics of mineral aggregates, weight per unit volume of compacted asphalt pavement varies considerably. Exact weights per unit volume should be determined in the laboratory from samples taken from the pavement or prepared in the laboratory with the same materials as used in the field.	Pounds Per Cubic Foot	Pounds Per Cubic Yard	Pounds Per Square Yard Per 1 inch Depth	
		100	2700	75
	105	2835	79	
	110	2970	83	
	115	3105	86	
	120	3240	90	
	125	3375	94	
	130	3510	97	
	135	3645	101	
	140	3780	105	
	145	3915	109	
	150	4050	112	
	155	4185	116	
	160	4320	120	
	Range	Range	Range	Frequently Used for Preliminary Estimate
Macadam-A.I. Type I or Penetration Macadam	110-135	2970-3645	82-101	95
Open Graded-A.I. Type II	115-140	3105-3780	86-105	100
Coarse Graded-A.I. Type III	130-150	3510-4050	97-112	105
Dense Graded-A.I. Type IV	135-155	3645-4185	101-116	110
Fine Graded-A.I. Type V	130-150	3510-4050	97-112	105
Stone Sheet-A.I. Type VI	130-150	3510-4050	97-112	105
Sand Sheet-A.I. Type VII	120-140	3240-3780	90-105	100
Fine Sheet-A.I. Type VIII	120-140	3240-3780	90-105	100
Mixed-in-Place Macadam-A.I. Spec. RM-1	110-135	2970-3645	82-101	95
Mixed-in-Place Dense Graded-A.I. Spec. RM-2	110-135	2970-3645	82-101	95
Mixed-in-Place Sand Asphalt-A.I. Spec. RM-3	100-125	2700-3375	75-94	85

Where

L = Length of project in feet.

W = Width of project in feet.

110 = Pounds per square yard of asphalt per 1-inch depth. (Example: A 2-inch mat will equal 220 pounds per square yard.)

9 = To obtain square yards from square feet, divide by 9.

2,000 = 2,000 pounds equal one ton; therefore, you must divide the total weight of material by 2,000, giving tons required.

WF = Waste factor equals 5% or .05, or 10% or .10, depending on the experience of the screed operators and handwork required on the project.

Example: The specifications for a parking lot paving project are as follows:

L = 90 feet

W = 30 feet

D = 2 inches

WF = .10

Find the amount of asphalt required for this project.

Solution:

$$\text{Equation 1} = \frac{30 \text{ Feet} \times 90 \text{ Feet} \times .167 \times 146}{2,000} = \frac{65831.4}{2,000} = 32.9$$

(32.9 is rounded off to 33)

$$WF = 33 \times .10 = 3.3 \text{ Total Tons Required} = 3.3 + 33 = 36.3$$

(36.3 is rounded off to 37)

$$\text{Equation 2} = \frac{30 \text{ Feet} \times 90 \text{ Feet}}{9} = 300 \text{ Square Yards} = \frac{300 \text{ Square Yards} \times 220}{2,000} = 33$$

$$WF = 33 \times .10 = 3.3 \text{ Total Tons Required} = 33 + 3.3 = 36.3$$

Placing Plant-Mix Materials

The material that arrives at the construction site from the plant must be spread. It must cover the entire

width of the road being paved. It is then struck off to the desired shape and thickness and compacted. Three general methods of spreading and shaping the material are in use today: hand spreading, blade spreading, and mechanical spreading.

HAND SPREADING.— Hand spreading is the oldest method used to spread and shape the mixed material. For this method, the mix is dumped from the trucks onto dump boards from which the material is shoveled onto the road or runway. After placement, it is raked smooth to grade and contour and compacted with a roller.

WARNING

Asphalt and bituminous materials contain coal tars, benzene, and other components which are suspected or known carcinogens. Workers should avoid inhalation of the vapors and prolonged skin contact with these materials. Review the Materials Safety Data Sheet (MSDS) for specific hazards and precautions.

Because of the high cost of labor and the inability to obtain a smooth and even-textured surface, hand spreading is not used to any great extent. It is used primarily to supplement the other spreading methods. For example, hand spreading is used effectively for adjacent curbing and around manholes.

When placing the material by hand, you should be extremely careful to prevent segregation of the mix. Do NOT throw the material a long distance and do NOT dump it from too great a height. Dump the material in small piles and level the material with shovels, rakes, and lutes. Use the shovel to move the excess material and the lute and rakes to level it. The material should be as level as possible before compacting it.

BLADE SPREADING.— Blade spreading is done with a grader by a skilled operator. The grader blade can obtain reasonably good surface smoothness. Each successive pass of the grader blade reduces the irregularities in the surface. Often, blade spreading is used in areas too large for hand spreading and inaccessible to mechanical spreading.

MECHANICAL SPREADING.— Specialized machines have been developed to spread bituminous paving materials. Self-propelled, these machines have crawler, wheels, or rollers which run on the base course foundation or surface. The mix from the plant is dumped into a hopper on the front of the paver. The paver places the mix evenly on the road itself. Figure

16-6 shows a bituminous paver that can handle any type of asphaltic mix.

Compacting Plant-Mix Materials

The most important phase of flexible pavement construction is compaction. When the specified density of asphalt pavement mix is not obtained during construction, subsequent traffic will further consolidate the pavement. This consolidation occurs principally in the wheel paths and appears as channels in the pavement surface.

Most mixtures compact quite readily when they are spread and rolled at temperatures that assure proper asphalt viscosity. Rolling should start as soon as possible after the material has been spread by the paver but should be done with care to prevent unduly roughening of the surface.

Mix temperature is a principal factor affecting compaction. Compaction can only occur while the asphalt binder is fluid enough to act as a lubricant. When it cools enough to act as an adhesive, further compaction is extremely difficult to achieve. The best time to roll an asphalt mixture is when its resistance to compaction is the least, while at the same time, it is capable of supporting the roller without excessive shoving of the asphalt material. The best rolling temperature is influenced by the interparticle friction of the aggregates, the gradation of the mix, and the viscosity of the asphalt; therefore, it can change if any of these factors change. The critical mix temperature in

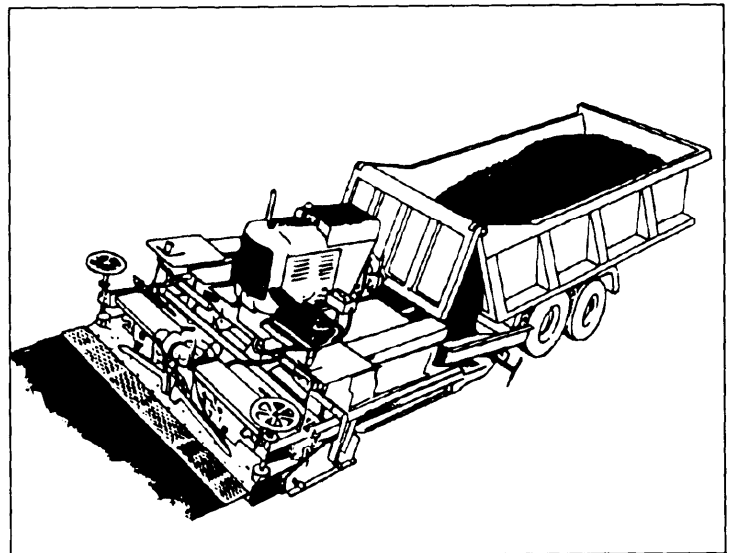

Figure 16-6. Bituminous paver.

an asphalt-paving project is the temperature at the time of compaction.

During rolling, the roller wheels must be kept moist with only enough water to avoid picking up material. Rollers move at a slow, but uniform, speed with the drive wheels nearest the paver. The speed should not exceed 3 mph for steel-wheeled rollers or 5 mph for pneumatic-tired rollers. A roller must be maintained in good condition, capable of being reversed without backlash. The line of rolling should not be suddenly changed or the direction of rolling suddenly reversed, because these actions will displace the mix. Any pronounced change in direction should be made on stable material.

When rolling causes material displacement, the affected areas should be loosened at once with lutes or rakes and restored to their original grade with loose material before being rerolled. Heavy equipment, including rollers, should not be permitted to stand on the finished surface before it has thoroughly cooled or set.

Rolling freshly placed asphalt mix is done in the following order:

1. Transverse joints
2. Longitudinal joints
3. Breakdown or initial rolling
4. Intermediate or second rolling
5. Finish rolling

The five steps in rolling freshly placed bituminous or asphalt mix are covered in chapter 11 of this TRAMAN.

MIXED-IN-PLACE CONSTRUCTION

Emulsified asphalt and many cutback asphalts (although the use of cutbacks is declining) are fluid enough to be sprayed onto and mixed into aggregate at moderate to warm weather temperatures. When this is done on the area to be paved, it is called **mixed-in-place** construction. Although mixed-in-place is the more general term and is applicable whether the construction is on a roadway, parking area, or airfield, the term *road mix* is often used when construction is on a roadway.

Mixed-in-place construction can be used for surface, base, or subgrade courses. As a surface or wearing course, it usually is satisfactory for light and medium traffic, rather than heavy traffic. However, mixed-in-place layers, covered by a high-quality asphalt plant-mix surface course, make a pavement suitable for

heavy traffic service. The advantages of mixed-in-place construction include the following:

1. Utilization of aggregate already on the roadbed or available from nearby sources and usable without extensive processing.
2. Elimination of the need for an asphalt mixing plant. Construction can be accomplished with a variety of machinery often more readily available, such as motor graders, rotary mixer with revolving tines, or traveling mixing plants.

ROAD-MIX PAVEMENTS

Road-mix pavements consist of mineral aggregate and mineral filler uniformly mixed in place with a bituminous material and compacted on a prepared base course or subgrade. A single layer, about 1 1/2 inches to 3 inches thick, is generally used. This type of pavement is likely to become defective unless it has a sound, well-drained subgrade and is well-mixed, uniformly spread, and properly compacted. Road-mix pavements may be used as a wearing surface on temporary roads and airfields and as a bituminous base or binder course in construction of more permanent types of roads and airfields. Road mix is an economical method of surfacing small areas when aggregate can be used from the existing base or when satisfactory aggregate is nearby.

For road-mix pavements, the grade and type of bituminous material depend upon the aggregate and equipment available as well as weather conditions and time required to complete the project. Good weather is important to the success of a road-mix project. Where possible, road-mixing operations should be scheduled when weather conditions are likely to be hot and dry during, and for some time after, the project. Recommended types of bituminous materials suitable for road mix are asphalt cutbacks, asphalt emulsions, and road tars. A medium-curing cutback is generally used in a moderate climate, and a rapid-curing cutback is used in a cold climate. Viscosity required is determined by the temperature, aggregate gradation, and method of mixing. The highest viscosity that will completely and uniformly coat the particles of aggregate should be used. In general, open-graded aggregate requires a high viscosity; a gradation, containing mineral filler, requires a less viscous grade.

Aggregate, used in road mix, may be scarified from the existing subgrade or hauled in from a nearby source. A wide range of coarse and fine aggregate and mineral filler may be used. The ideal aggregate for road-mix

pavement is a well-graded (dense or open) sandy gravel or clean sand. Maximum size of the aggregate, in general, is limited to two thirds of the compacted thickness of the layer. Loose thickness is approximately 1 1/4 times the desired compacted thickness.

“Surface moisture” is defined as the film of water around each particle of stone or sand. The amount present is determined by heating a weighed sample of aggregate at 212°F in an open pan and stirring it with a rod until the surface water disappears (3 to 10 minutes). The difference between the original and final weights is considered to be moisture lost during drying. The loss in weight, expressed as a percent of the final or dry weight, is the moisture content, allowed before the aggregate is mixed with asphalt cutbacks or road tars. When the aggregate is too wet, it should be worked with mechanical mixers, graders, or improvised plows to allow the excess moisture to evaporate. For cutbacks and tars, moisture content of coarse-graded aggregate should not exceed 3 percent, and of fine-graded aggregate, 2 percent. For emulsions, moisture content of coarse-graded aggregate should not exceed 5 percent, and of fine-graded aggregate, 3 percent.

The quality of the road-mix pavement depends largely upon the control of the mix. The percentage of bitumen will vary in relation to the absorptive quality of the aggregate, rate of evaporation of the volatile substances, and other factors. Although an exact formula is difficult to follow, proportioning must be controlled within narrow limits to assure the stability and life of the mix. With dense-graded aggregates especially, too much bitumen should not be used. All particles of the completed mix should be coated and uniform in color. When the mix is too lean, the aggregate in the windrow will stand almost vertically and have a dull look; and when the mix is too rich, it will ooze or slip out of shape. When the mix is correctly proportioned, a handful, squeezed into a ball, will retain its shape when the hand is opened.

Road-mix pavements should be constructed only on a dry base when the weather is not rainy. Atmospheric temperature should be above 50°F. Mixing should take place at the temperature of the aggregate, but not below 50°F or above the recommended temperature of the liquid asphalt being used. The construction procedure depends upon whether the base is a newly constructed base, a scarified existing base, or an existing pavement.

When a newly constructed base is used, perform the following procedure:

1. Inspect and condition the base.
2. Prime the base and allow the prime to cure.
3. Haul in and windrow the aggregate at the side of the primed base. (Allow the aggregate to dry or aerate with a blade when wet.)
4. Spread the aggregate on the cured prime base one half of the roadbed width.
5. Spray the bitumen on the aggregate in increments of about one third of the total amount required.
6. Mix the bitumen with the aggregate; blade back and forth until a uniform mix is obtained.
7. Repeat as directed in (5) and (6) until thoroughly mixed.
8. Spread the mix to the specified thickness.
9. Compact the surface.
10. Apply a seal coat when necessary.

For a scarified base, the aggregate is scarified when it is not available from other sources. The construction procedures are as follows:

1. Loosen the aggregate from the base.
2. Dry and breakup all lumps of material.
3. Blade into parallel windrows of uniform size at one side or in the center.
4. Sweep the base, when needed
5. Prime the base and allow time to cure.
6. Continue as directed in (4) through (10) in the above procedures for a newly constructed base.

When an existing pavement is to be used as a base, the construction procedures are as follows:

1. Sweep the base.
2. Apply a tack coat and allow it to cure.
3. Bring in the aggregate and deposit in windrows at the side of the cured, tacked base.
4. Aerate the aggregate.
5. Spread the aggregate on one half of the tacked base.
6. Spray bitumen on the aggregate in increments of about one third of the total amount required
7. Mix the bitumen with the aggregate by blade.
8. Spread the mix to specified uncompacted thickness.

9. Compact the surface.

10. Apply a seal coat when necessary.

When you are mixing in place (road mix), here are some helpful hints:

1. Do not try to buck nature; stop operations when you are working under adverse weather conditions.

2. Keep the mixture or aggregate in a well-packed windrow for better water shedding and control.

3. Provide drainage cuts through the windrow during heavy rains.

4. When a grader comes to the end of a section with a full blade, lift the blade rapidly to avoid carrying materials into the next section.

5. The distributor spray must be cut sharply at sectional joints; carry-over to the next section will cause undesirable fat joints.

6. Plan the work to avoid inconvenience to traffic.

7. Apply the asphalt at the recommended spraying viscosity to ensure uniform application.

8. Using a shoe on the outer end of the grader blade or moldboard helps obtain a good edge during spreading operations.

9. Aggregate in shaded areas usually requires extra aeration.

ROAD-MIXING METHODS

Two methods of road mixing are travel plant mixing and blade mixing.

Travel Plant Mixing

When a travel plant is used for mixing (fig. 16-7), the loose aggregate is dumped, mixed, and bladed into uniform windrows, and evened when necessary. The windrow should be sufficient to cover the section of the area to be paved with enough loose material to give the desired compacted depth and width. As the bucket loader tows the mixer and elevates the aggregate to the mixer hopper, the mixer meters the aggregate, sprays it with the correct amount of bitumen, mixes these two uniformly, and redeposits the mix into another windrow behind the plant. The rate of travel and the mixing operation should be controlled so that all particles of the aggregate are coated and the mix is uniform. Accuracy in proportioning the mix is extremely important.

The travel plant method usually produces a more uniform mix of higher quality than blade mixing.

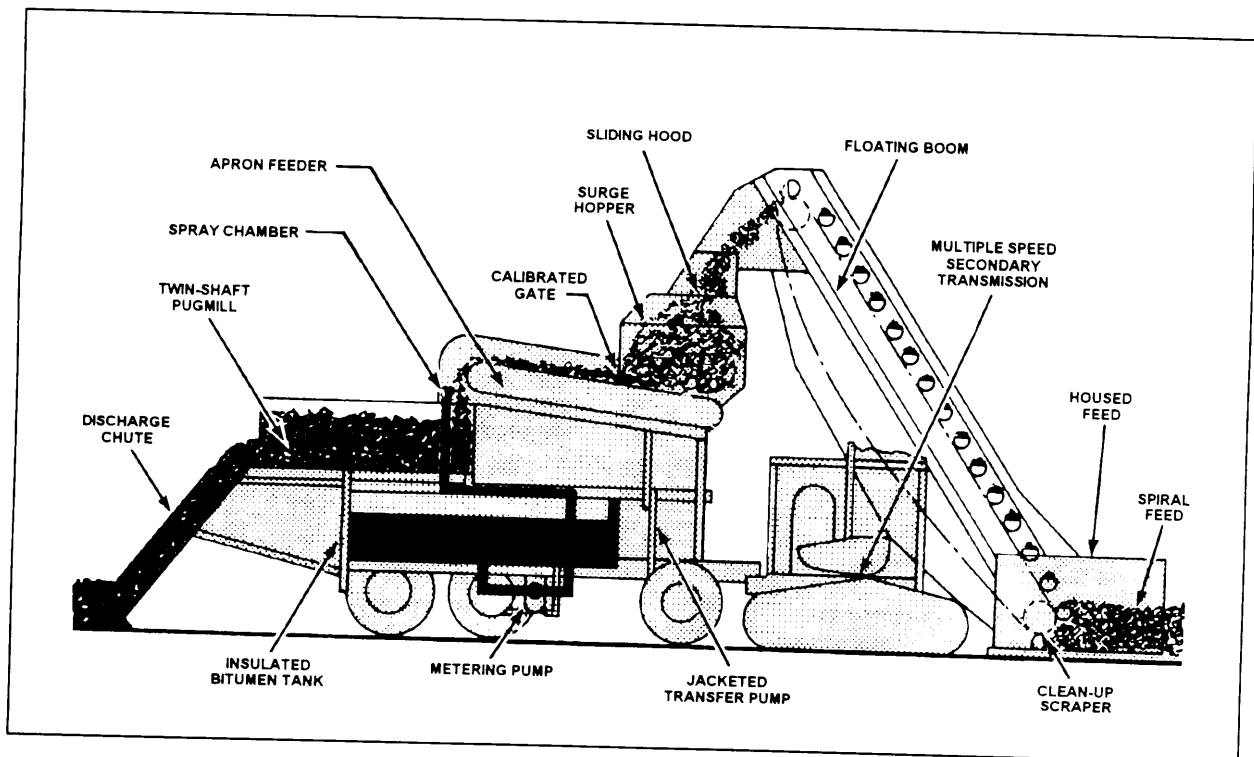

Figure 16-7.-Schematic layout of a travel plant.

Heavier types of asphalt cutback and tar maybe used in the travel plant method, which reduces the time required for curing. The asphalt finisher may be used concurrently with the travel plant. The hopper of the finisher is kept directly under the travel plant output chute. This arrangement reduces the maximum output of the plant, although it does provide uniform thickness of the mat being laid.

Windrows must contain no more material than the finisher can place. The major advantage of this setup is

that in-place aggregate may be used in an intermediate mix and placed with a finisher without the necessity of loading and transporting aggregate. The finisher must be used with the travel plant for construction of some airfields when surface tolerances are critical.

Blade Mixing

In blade mixing, the aggregate is dried and bladed into windrows (fig. 16-8). The windrows are then flattened and the bitumen of the specific temperature is

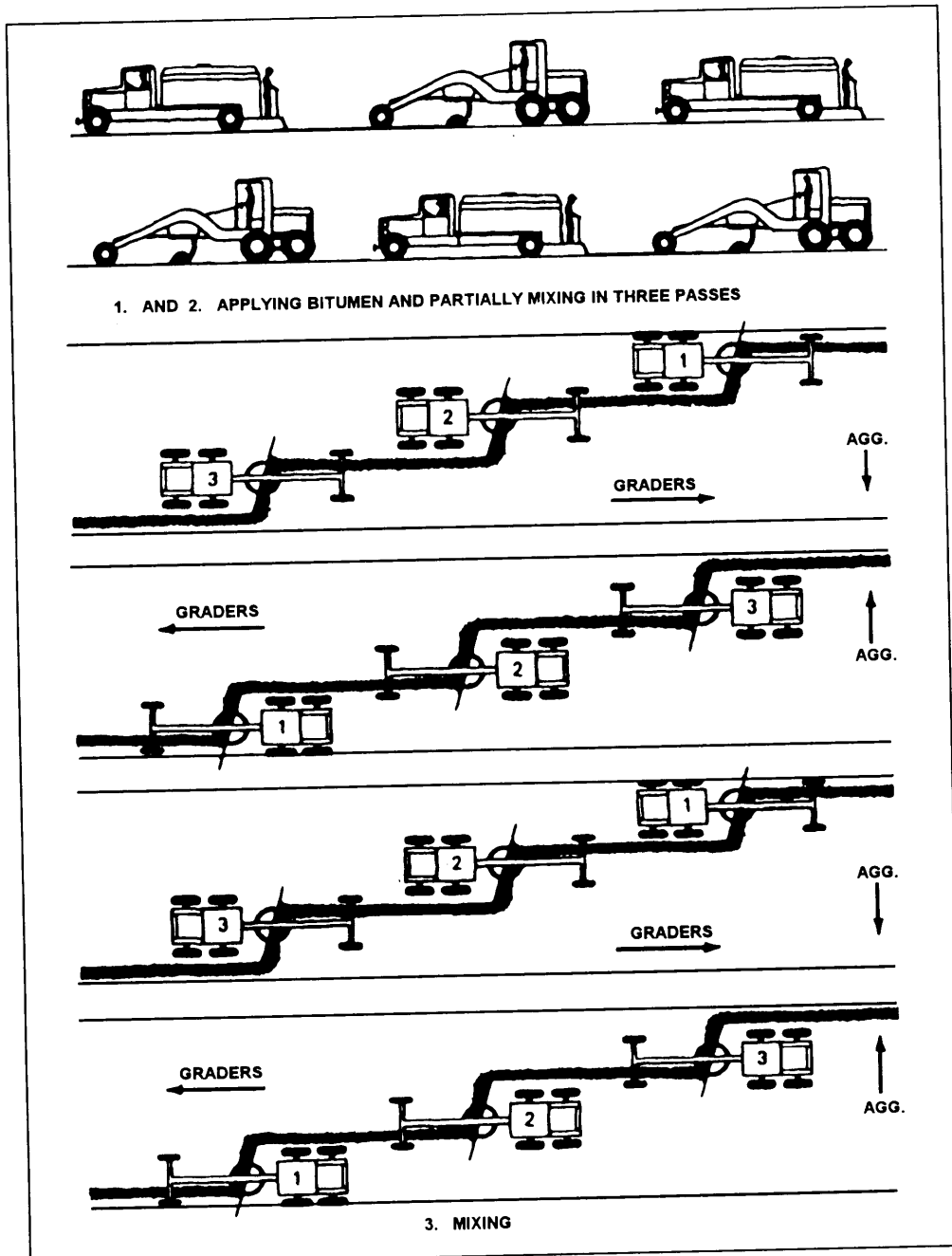

Figure 16-8. Blade-mix construction.

applied with a bituminous distributor in three equal applications. Each application is one-third of the amount required.

Immediately following each application of the bituminous material, the treated aggregate should be mixed with spring-tooth or double-disk harrows, graders, rotary tillers, or a combination of this equipment until all the particles of the aggregate are evenly coated. When a grader is used, the windrow is moved from side-to-side by successive cuts with the blade.

Several graders can operate, one behind the other, to reduce the total time required for complete mixing. In hilly terrain, blading should be from the bottom to the top, as the mix tends to migrate down. After all the aggregate has been mixed, the mix should be bladed into a single windrow at or near the center of the road and turned not less than four complete turns from one side of the road to the other. Excess bitumen, a deficiency of bitumen, or uneven mix should be corrected by the addition of aggregate or bituminous material, followed by remixing. Mixing should continue until it is complete and satisfactory; remember, mix will set up if mixed too long.

Suppose that materials, weather conditions, and equipment are well-suited to mixed-in-place paving, but the road or airfield must carry traffic during construction. In such cases, the windrowing of aggregate and the mixing and spreading of bitumen may be done elsewhere—on any area of smooth ground which can be compacted for the purpose or on any unused road or airfield surface. The road or airfield surface, base, or subgrade to be paved is then primed or tack-coated as required to complete construction and to keep portions of the road or airfield open to traffic. As soon as the prime or tack coat cures, the mix is picked up, trucked to the jobsite, dumped, and then bladed into windrows for spreading.

The bituminous mix should not be spread when the surface is damp or when the mix itself contains an excess of moisture. The mixed material should be spread to the required width in thin, equal layers by a grader or finisher. (When a finisher is used, additional support equipment is required, and the material must be split into two windrows for an 8- to 12-foot-wide pavement.) When spreading the mix from a windrow, you should take care to prevent cutting into the underlying subgrade or base course. To prevent such cutting, you should leave a layer of mix, approximately one-half inch thick, at the bottom of the windrow.

The material being spread should be rolled once and then leveled with a grader to remove irregularities. The remaining material should be spread and rolled in thin layers until the entire mix is evenly spread to the depth and width specified. During the spreading and compacting, the surface should be dragged or bladed, as necessary, to fill any ruts and to remove corrugations, waves, or other irregularities. Both pneumatic-tired and steel-wheeled rollers may be used for rolling all surface treatment jobs; however, the pneumatic-tired roller is the preferred type.

After all layers have been satisfactorily spread, the surface should be rolled with two-axle tandem rollers. Rolling should begin at the outside edge of the surface and proceed to the center, overlapping on successive trips at least one half of the width of the wheel of the roller. Alternate trips of the roller should be of different lengths. The speed of the roller at all times should be controlled to avoid displacement of the mix. Light blading (or floating) of the surface with the grader during rolling may be required. Rolling should be continued until all roller marks are eliminated and maximum density is obtained. To prevent adhesion of the mix to the roller, you should keep the roller wheel moist with water; use only enough water to avoid picking up the material. At places not accessible to the roller, the mix should be thoroughly compacted with hand tampers. When the surface course becomes rough, corrugated, uneven in texture, water soaked, or traffic marked, unsatisfactory portions should be torn up and reworked, relaid, or replaced. When forms are not used and while the surface is being compacted and finished, the outside edges should be trimmed neatly in line.

When the road-mix pavement surface course is constructed from an open-graded aggregate, a surf treatment may be required to waterproof the surface. A surface treatment is unnecessary on a dense-graded, well-compacted, road-mix pavement.

When possible, traffic should be kept off freshly sprayed asphalt or mixed materials. When it is necessary to route traffic over the new work speed must be restricted to 25 mph or less until rolling is completed and the asphalt mixture is firm enough to withstand high-speed traffic.

DEFECTS IN FLEXIBLE PAVEMENTS

Defects in flexible pavements can be placed into one of five classes. These classes are cracking, distortion, disintegration, slippery surfaces, and surface treatment problems.

Cracking

Cracking takes many forms. To make the proper repairs, first you should determine the type of crack and the cause. The most common types of cracks are alligator, edge, edge joint, lane joint, reflection, shrinkage, and slippage.

ALLIGATOR CRACKS.— Alligator cracks are interconnected cracks, forming a series of small blocks resembling an alligator's skin or chicken wire (fig. 16-9). In most cases, alligator cracking is caused by excessive movement of the surface over unstable subgrades or base courses. The unstable support is the result of saturated granular bases or subgrade. Normally, the affected area is not large. When it does occur on a large scale, the cracking is most likely due to repeated loads above the designed strength of the pavement.

EDGE CRACKS.— Edge cracks are longitudinal cracks approximately 1 foot from the edge of the

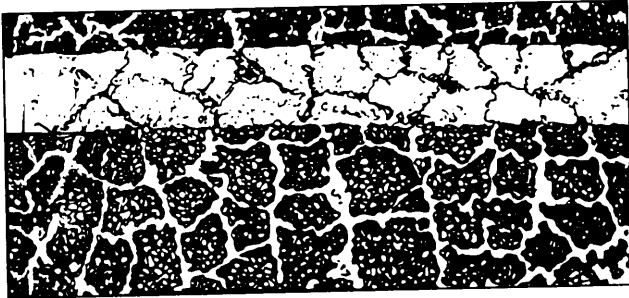

Figure 16-9.—Alligator cracks.



Figure 16-10.—Edge cracks.

pavement (fig. 16-10). Edge cracks can have transverse cracks, branching in towards the shoulder. Normally, edge cracks are caused by a lack of side or shoulder support. They may also be caused by settlement or yielding of the base material underlying the cracked area. This, in turn, may be the result of poor drainage, frost heave, or shrinkage from the drying out of the surrounding earth.

EDGE JOINT CRACKS.— Edge joint cracks occur between the pavement and the shoulder (fig. 16-11). They are normally caused by alternate wetting and drying beneath the shoulder surface. This can result from poor drainage from a shoulder that is too high, or it can result from depressions along the pavement edge. The uneven pavement traps water on top, allowing it to seep into the base. Another cause could be heavy trucks, straddling the joint.

LANE JOINT CRACKS.— Lane joint cracks are longitudinal separations along the seam between two paving lanes (fig. 16-12). This type of crack is usually caused by a weak seam or poor bond between adjoining spreads in the pavement.

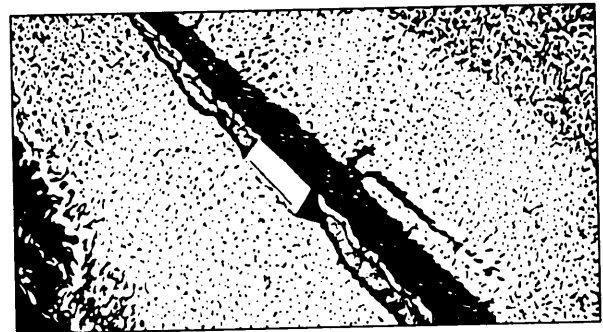

Figure 16-11.—Edge joint cracks.

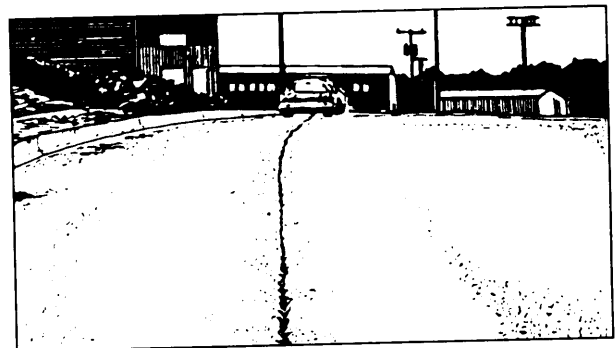

Figure 16-12.—Lane joint cracks.

REFLECTION CRACKS.— Reflection cracks normally occur in asphalt overlays. These cracks reflect the crack pattern in the pavement structure underneath (fig. 16- 13). They are most frequently found in asphalt overlays over portland concrete and cement-treated bases. Reflection cracks are normally caused by vertical or horizontal movements in the pavement beneath the overlay, resulting from traffic loads, temperature, and earth movements.

SHRINKAGE CRACKS.— Shrinkage cracks are interconnected cracks, forming a series of large blocks usually with sharp corners or angles (fig. 16-14). Often it is difficult to determine whether shrinkage cracks are caused by volume change in the asphalt mix or in the base or subgrade. Frequently, they are caused by

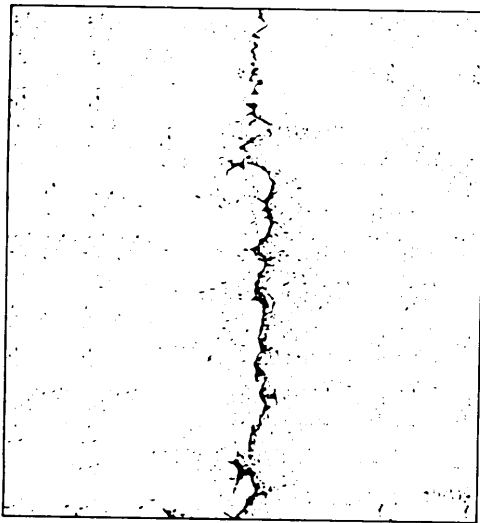

Figure 16-13. Reflection cracks.

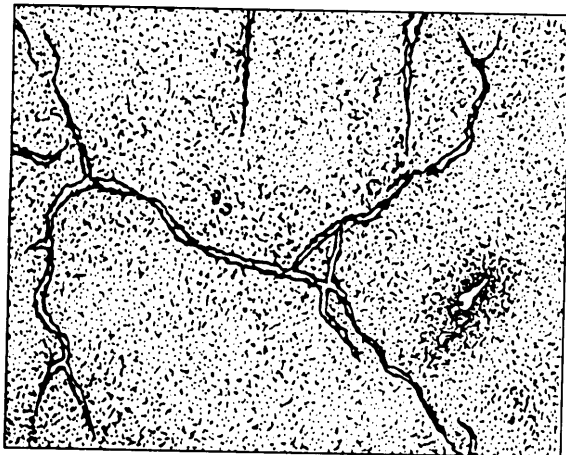

Figure 16-14.—Shinkage cracks.

volume change of fine aggregate asphalt mixes that have a high content of high-viscosity asphalt. Lack of traffic hastens shrinkage in these pavements.

SLIPPAGE CRACKS.— Slippage cracks are crescent-shaped cracks, resulting from horizontal forces induced by traffic (fig. 16-15). They are caused by a lack of bond between the surface layer and the course beneath. Lack of bond maybe due to dust, dirt, oil, or the absence of a tack coat.

Distortion

Pavement distortion is any change in a flexible pavement surface. It is the result of a subgrade surface weakness where compaction or movement of the subgrade soil has taken place or where base compaction has occurred. It may or may not be accompanied by cracking, but in either instance, it creates a traffic hazard, permits water to accumulate, and eventually makes matters worse. Distortion takes a number of different forms but is normally classed as channeling, corrugations and shoving, depressions, and upheaval.



Figure 16-15.—Slippage cracks.

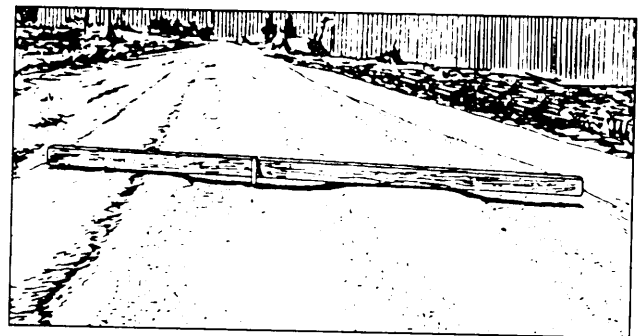

Figure 16-16.—Channeling.

CHANNELING.— Channeling, also referred to as “grooving” or “rutting,” is channelized depressions that develop in the wheel tracks of flexible pavements (fig. 16-16). Channeling may result by consolidation or lateral movement under traffic in one or more of the underlying courses or by displacement in the bituminous surface itself. It may develop under traffic in new flexible pavements that had too little compaction during construction or from plastic movement in a mix that does not have enough stability to support traffic.

CORRUGATIONS AND SHOVING.— Corrugation, or washboarding, are a form of plastic movement typified by ripples across the flexible pavement surface (fig. 16-17). Shoving is the plastic movement of the pavement, resulting in localized bulging of the pavement (fig. 16-18). Both corrugations and shoving normally occur at points where traffic starts and stops or on hills where vehicles brake on the downgrade.

Corrugations and shoving usually occur in flexible pavement mixtures that lack stability. This may be the result of too much binder, too much fine aggregate, or round- or smooth-textured coarse aggregate. In the case

of emulsified and cutback asphalt mixes, it may be due to a lack of aeration.

DEPRESSIONS. — Depressions are localized areas of limited size that may or may not be accompanied by cracking (fig. 16-19). Water collects in depressions that then become not a source of pavement deterioration but a hazard to motorists. Depressions are caused by traffic heavier than that for which the pavement was designed, by poor construction methods, or by consolidation deep within the subgrade.

UPHEAVAL.— Upheaval is the localized upward displacement of the pavement due to swelling of the subgrade or some portion of the pavement structure (fig. 16-20). It is commonly caused by ice expansion in the granular courses beneath the pavement or in the

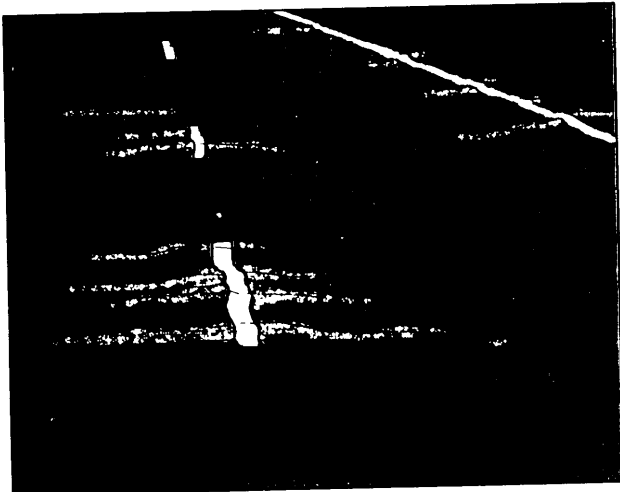

Figure 16-17.-Corrugations.



Figure 16-18.-Shoving.

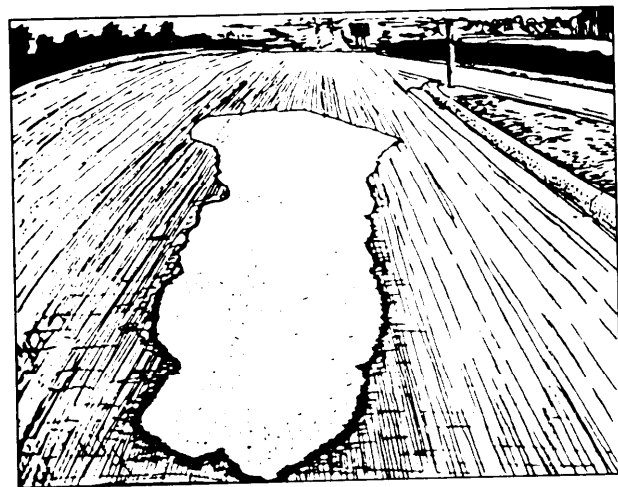

Figure 16-19.—Depression.



Figure 16-20.—Upheaval.

subgrade. Upheaval may also be caused by the swelling effect of moisture on expansive soils.

Disintegration

Disintegration is the breaking up of a pavement into small, loose fragments. This includes the dislodging of aggregate particles. If not stopped in its early stages, disintegration can progress until the pavement requires complete rebuilding. Potholes and raveling are two of the more common types of early stage disintegration.

POTHOLES.— Potholes are bowl-shaped holes of various sizes in the pavement, resulting from localized disintegration under traffic (fig. 16-21). They are usually caused by weakness in the pavement, resulting from too little binder, too thin a surface, too many fines, or poor drainage.

RAVELING.— Raveling is the progressive loss of surface material by weathering or traffic abrasion (fig. 16-22). Usually the fine aggregate wears away first, leaving little pockmarks in the pavement surface. As erosion continues, larger particles eventually break free, and the pavement soon has the rough and jagged appearance, typical of surface erosion. Raveling is caused by poor construction methods, inferior aggregates, or poor mix design.

Slippery Surfaces

One of the most common causes of a slippery flexible pavement is a thin film of water over a smooth surface. This can cause a vehicle to hydroplane. Other causes of slippery surface in flexible pavements are bleeding and polished aggregates.

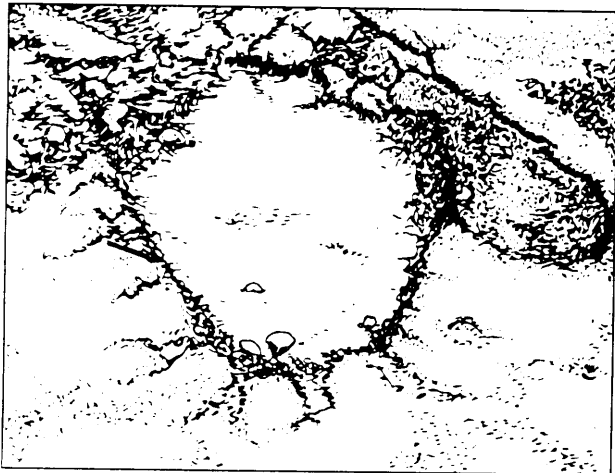

Figure 16-21. Pothole.



Figure 16-22.—Raveling.

BLEEDING AGGREGATES.— Bleeding is the upward movement of bituminous material in a flexible pavement, resulting in the formation of a film of bituminous material on the surface (fig. 16-23). The most common cause of bleeding is too much asphalt in one or more of the pavement layers. This is usually the result of a rich plant mix or a prime or tack coat that is too heavy. Bleeding normally occurs in hot weather.

POLISHED AGGREGATES.— Polished aggregates are those that have been worn smooth under traffic (fig. 16-24). Polished aggregates are caused by using the wrong type of aggregate in the pavement mix.

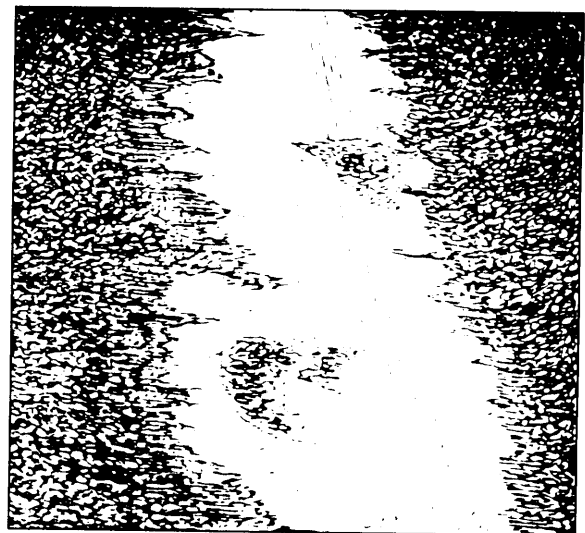

Figure 16-23. Bleeding asphalt.



Figure 16-24.—Polished aggregate in pavement surface.

REPAIRING DEFECTIVE FLEXIBLE PAVEMENTS

Care and good judgment are necessary in applying suitable methods and in selection of proper materials for maintenance and repairs of bituminous surfaces. Both methods and materials vary considerably with local conditions, but the principles of bituminous work remain the same. The first step in making repairs is to determine the cause of the failure. Repairs must start at the source of the failure.

Removing Defective Flexible Pavement

The first step in removing a defective area is to mark out the area you want to remove. If you are going to use a pavement saw to cut the pavement, make your marks heavy and easy to use. The marks should be made with a waterproof material, such as paint or crayon, to prevent it from being washed off by the saw blade. The shape of the patch is important. If you expect the patch to be strong enough to support traffic, you must make the marked area square or rectangular in shape with two faces at right angles to the flow of traffic. By doing this, you will ensure the patch does not shove or corrugate when traffic flows over the top of it.

PAVEMENT CUTTING.— After you mark the area you want to remove, you are now ready to make your cuts along the marks. You can do this by using a pavement saw to make a fast, neat cut or by using a pneumatic hammer with a 5-inch asphalt cutting bit. When the pneumatic hammer is used, it leaves the edges

of the patch jagged. When making the cut with either tool, make sure the patch has square edges and is rectangular in shape. The cut should also extend at least a foot into the good pavement.

PAVEMENT REMOVAL.— After the outline cuts have been made, you can begin to breakup the defective material with a pneumatic hammer. Break the pavement into pieces that can be removed easily by hand. If the pieces are too large, a front-end loader maybe required to remove them. After the pavement has been broken up, the pieces can then be removed and hauled away (fig. 16-25).

After the pavement has been removed, check the condition of the base course material. When the base course is saturated with water, this material should be removed until you reach firm, dry soil. The sides should be vertical and the bottom as level as possible.

Base Course Replacement

After the hole is excavated, clean out all loose debris with hand brooms. When the hole is wet, it must be allowed to dry. When the hole is deeper than the pavement, it should be filled with dense-graded aggregate. Fill and compact it in 2-inch lifts up to the lower edge of the pavement. On large patches, compaction can be done with a roller. Small patches must be hand-tamped. On large patches, the edges must be hand-tamped.

NOTE: Specification may require that a compaction test be performed on the base course before a prime coat application.

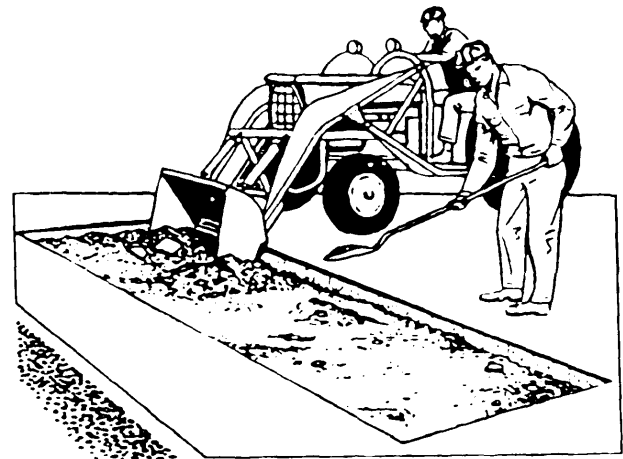

Figure 16-25.—Removing defective flexible pavement.

After the base course has passed the compaction test, prime the hole with a light application of asphalt, which can either be sprayed or brushed on. The prime material must be thin enough so that it can be applied lightly.

NOTE: An excess of asphalt prime coat will flush into the patch mix and causes bleeding.

The final step in the preparation of the hole is to apply a tack coat to the vertical faces, as shown in figure 16-26.

Bituminous Materials Replacement

The first step in the replacement of the paving materials is to obtain a sufficient quantity of material to complete the project. Use a hot mix if possible because it is stronger and lasts much longer. To allow for compaction when using a hot mix, you should overfill the area approximately 40 percent of the pavement thickness. When a cold mix is used, it should be spread and rolled in layers with each layer not to exceed 1 1/2 times the maximum aggregate size in the mix. When cold mix is spread, keep the material as level as possible to prevent segregation. Both hot and cold mixes can be spread by grader, by paver, or by hand, depending on the size of the repair.

Compaction of bituminous materials is done with steel-wheel rollers and pneumatic-tired rollers on larger areas, or with vibrator tampers, vibratory patch rollers, and hand tampers on smaller areas. Compaction is an important part of the patching operation. The rolling operation on hot mix should begin immediately after the material is placed. Cold mix should be rolled after

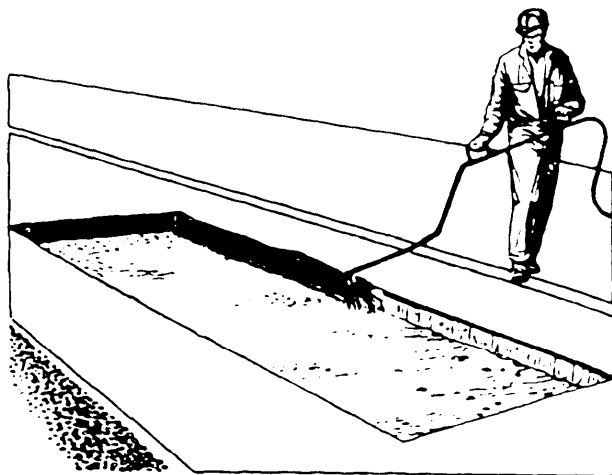

Figure 16-26.-Tack coat application to the vertical faces.

proper aeration of the material. The edges of the patch should be rolled first. This seals the edges and prevents the material from dishing out and water from infiltrating. When cold mix is used, the patch may have a porous surface and require waterproofing. This can be done by applying a sand seal or by applying a thin layer of portland cement and tamping it in.

Obtaining a smooth riding surface requires care. Too many patches are built as mounds that result as bumps in the road. A straightedge should be used as a guide to finish the patch. The patch should not be lower than the rest of the pavement. Instead, it should be level with or one-eighth inch higher than the surrounding area. Figure 16-27 shows the steps in patching a pothole.

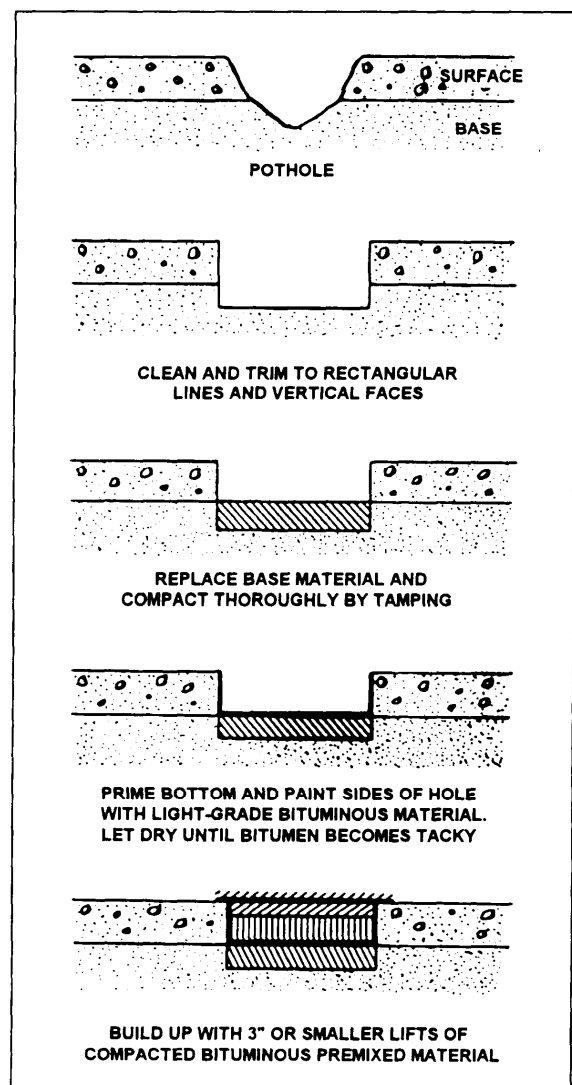

Figure 16-27.-Steps in patching a pothole.

SURFACE TREATMENTS

A surface treatment is an application of asphalt materials to any type of road surface with or without a cover of mineral aggregate. This application produces an increase in thickness usually less than 1 inch. Surface treatments have a variety of uses. They waterproof, provide a nonskid wearing surface, and rejuvenate an old surface.

Purposes

The simplest types of bituminous surfaces that may be placed over prepared surfaces are called surface treatments. Surface treatments are applications of bituminous material to any type of base or pavement surfaces which, together with an aggregate cover, produce a pavement with a thickness of 1 inch or less. In some cases, multiple treatments that produce thicker pavements are used.

Surface treatments are applied for one or more of the following purposes:

1. Waterproof the surface.
2. Provide a wearing surface.
3. Make the surface nonskid.
4. Prevent hydroplaning.
5. Rejuvenate an old road or runway.
6. Make permanent improvements.

Types

Surface treatments may be applied to the base course of a new road or to the surface of an old road as a method of repair. Surface treatments are grouped into three categories: sprayed asphalt, sprayed asphalt with cover aggregates, and asphalt-aggregate mixtures.

Sprayed Asphalt Surface Treatment

Sprayed asphalt treatments contain no aggregates. They are simply applications of different types of asphaltic materials to a prepared surface. The categories include fog seals, dust laying, and road oiling. Prime and tack coats are also considered as a sprayed asphalt treatment.

FOG SEAL.— A fog seal is a light application of diluted slow-setting asphalt emulsion, used to renew old asphalt surfaces and seal small cracks and surface voids. Fog seals are especially useful for pavements

carrying a low volume of traffic. A fog seal may also be used for the following:

1. To seal surface voids in new asphalt plant mixes
2. To prevent dust on sprayed asphalt with cover aggregate surface treatments
3. To increase aggregate retention
4. To provide a uniform dark color

The asphalt emulsion is diluted with an equal amount of water, and the diluted material is sprayed at the ROA of 0.1 to 0.2 gallon per square yard, depending on the texture and dryness of the old pavement. In normal conditions, the separation and evaporation of the water is rapid, permitting traffic within 1 or 2 hours.

DUST LAYING.— Dust laying consists of spraying an untreated surface with a low-viscosity liquid asphalt, such as SC-70, MC-30, MC-70, or a diluted slow-setting asphalt emulsion. The asphalt and dilutant penetrate and coat the fine particles and temporarily relieve the nuisance of dust.

The material is sprayed at a ROA of 0.1 to 0.5 gallon per square yard. When emulsion is used, it should be diluted with 5 or more parts of water by volume. Diluted emulsion dust-laying treatments usually require several applications. The dust stirred by traffic between applications eventually conglomerates and no longer rises. This is an effective treatment in a very dusty environment where one application of asphalt is insufficient.

ROAD OILING.— Road oiling differs from dust laying in that it is usually accomplished as part of a planned buildup of low-cost road surfaces over several years. Each application may be mechanically mixed with the material being treated, or it maybe allowed to penetrate. The light oils in the road oil penetrate into the subgrade and tend to repel moisture absorption. The objective in all road oiling work is to form a dustless wearing surface, combined with a strong water-repelling subgrade.

Because soils vary widely, procedures for oiling are a matter for local trial and error, rather than scientific analysis. The amount of road oil, required in the first year of work will vary from 0.75 to 1.0 gallon per square yard. The first application is applied at the ROA of about one half of the total; succeeding applications are made in equal amounts.

Road oiling treatments are placed several weeks apart, depending upon the character of the asphalt soil mat. If some breakup occurs after the first winter, light

scarifying and retreatment the second year will produce a thicker and stronger surface.

WARNING

Before planning any road oiling work your supervisor should check with local authorities concerning environmental protection restrictions.

Aggregate Surface Treatment

The sprayed asphalt with aggregate cover surface treatments are applications of liquid asphalt, followed by an application of aggregate. This can be done in one or more layers of construction. Two types of sprayed asphalt with covered aggregate surface treatments are in use today: single- and multiple-surface treatments.

SINGLE-SURFACE TREATMENT.— Single-surface treatments are thin, bituminous-aggregate toppings, applied to existing bases or surfaces, such as

concrete or asphalt. Construction involves applying a bituminous prime or tack coat to the base or surface. This coating is followed by an application of bitumen and small-sized aggregate. Single-surface treatments are sometimes called seal coats, because they seal the surface of the road or runway.

Sequence of Operations.— Figure 16-28 shows the sequence of operations for the application of a single-surface treatment. The first steps, such as sweeping, priming or tacking, and curing, are the same as those used for applying a prime coat. The binder (bituminous material) is applied over the prime coat with an asphalt distributor. The aggregate is then spread over the binder by use of aggregate spreaders. The aggregate cover is spread uniformly immediately behind the distributor. As soon as the aggregate is spread, it is pushed into the soft asphalt by rolling it with a pneumatic-tired roller.

Binder Application.— When you are applying the binder, it should be hot enough to spray properly and

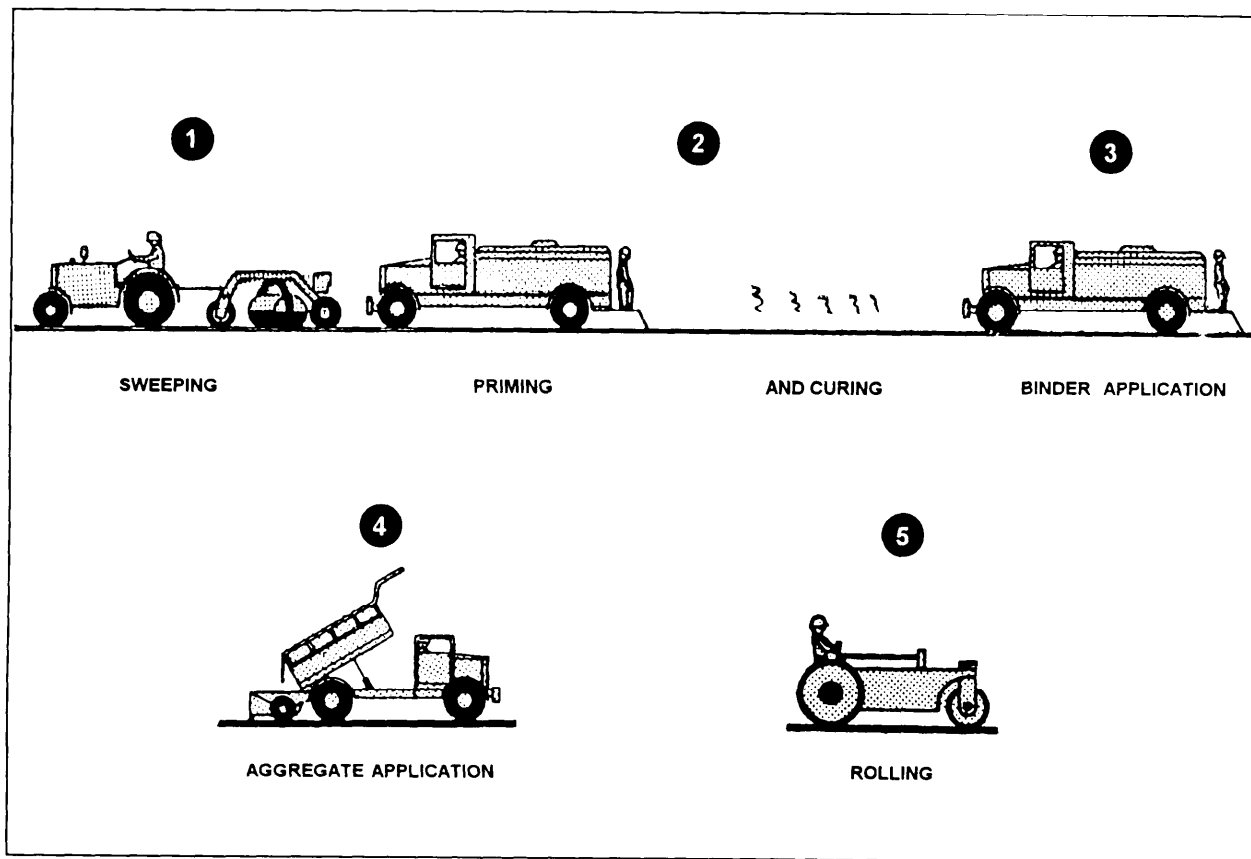

Figure 16-28. Sequence of operations for the application of a single-surface treatment.

cover the surface uniformly. After the binder cools and cures, it should bind the aggregate tightly to prevent dislodgement by traffic. Individual aggregate stones should be pressed into the binder but must not be covered by the binder. Approximately one half of the individual aggregate stones should be exposed to traffic. The ROA for the binder material should be between 0.25 and 0.30 gallon of asphalt per square yard.

For a single-surface treatment, the bitumen must be heated and applied to the surface while hot. The aggregate must be spread and rolled before the bitumen cools. Under no circumstances is traffic permitted to travel upon uncovered fresh bitumen. The distributor should NOT apply bitumen until the aggregate is on hand and ready for application. When the distributor moves forward to spray the asphalt, the aggregate spreader should start right behind it. The bitumen should be covered within 1 minute if possible; otherwise, the increase in asphalt viscosity may prevent good binding of aggregate.

Aggregate Application.— The size and amount of aggregate, used for surface treatments, are important. You must use a size that matches the bitumen application rate. For a single-surface treatment, one-half inch to sieve number 4 is needed. The amount of aggregate should be 25-30 pounds per square yard.

When aggregate is distributed properly, very little hand work is required. At longitudinal joints, the aggregate cover is stopped 8 inches from the edge of the bitumen to ensure ample overlap of the bitumen coat. All bare spots should be covered by hand spreading, and any irregularities of the distribution should be corrected with hand brooms. Excess aggregate in limited areas should be removed immediately with square-pointed shovels. When the aggregate spreader is properly set and operated, handwork is reduced to a minimum.

Rolling.— The aggregate is usually rolled by pneumatic-tired rollers. Steel-wheeled rollers are not recommended by themselves. If used, they should make only one pass (one trip in each direction). The rolling operation should then be completed with the pneumatic-tired rolls. Steel-wheeled rollers produce maximum compaction but must be used with care to prevent excessive crushing of the aggregate particles. Also, these rollers will bridge over smaller size particles and small depressions in the surface and will fail to press the aggregate in these places in the asphalt.

Faulty rolling can be eliminated or minimized if you adhere to the following procedures:

1. Rolling should be parallel to the center line of the roadway to reduce the number of times the roller must change direction.
2. Succeeding passes should overlap one half of the wheel width of the roller. This action ensures that the aggregate becomes well embedded in the bitumen.
3. Rolling should be completed before the bitumen hardens. This will ensure that the aggregate becomes well embedded in the bitumen.
4. Succeeding passes should be made from the low side to the high side of the surface. This operation maintains the surface crown and prevents feathering at the edges.
5. Rolling should be done at a slow speed.
6. Rollers should be only wet enough to prevent bitumen from sticking to the wheels.
7. The power wheel of the roller should pass over the unrolled surface before the steering wheel(s) of the rollers.

After rolling and curing, the surface is ready for traffic. When the surface is used as an airfield, excess aggregate must be swept from the surface to avoid damage to aircraft. This practice is also recommended for roads.

MULTIPLE-SURFACE TREATMENT.— A multiple-surface treatment is essentially the same as the single-surface treatment. However, the multiple-surface treatment consists of two or more successive layers of binder and aggregate.

This type of treatment is done in stages. Each stage is accomplished in the same manner as a single-surface treatment. The only difference is that each additional layer of aggregate should be about one half of the size of the previous layer. This allows the smaller aggregate to interlock with the larger aggregate when rolled.

PAVING EQUIPMENT

Equipment, used in asphalt pavement construction, are aggregate spreaders, asphalt distributors and their associated hand sprayers and spray bars, asphalt kettles, asphalt haul trucks, and asphalt pavers.

AGGREGATE SPREADERS

When a spreader is operated properly, it will conserve aggregate and produce a uniform spread. Spreaders range from a type attached to a truck tailgate to a highly efficient self-propelled machine.

Several types of tailgate spreaders are in use today. The simplest is the vane spreader (fig. 16-29).

There are tailgate spreaders that consist of a hopper with a feed roller, activated by small wheels driven by contact with the truck wheels (fig. 16-30).

Mechanical spreaders are hoppers on wheels that are hooked onto and are propelled by backing aggregate

trucks. Hoppers have various widths and capacities. They usually contain augers to distribute the aggregate the full width of the box. They have controls to regulate feed gates, feed roll, augers, and the truck hitch. All tailgate and mechanical spreaders that are pushed by a truck have the disadvantage that the truck must be operated in reverse with consequent loss of steering control and reduction in speed.

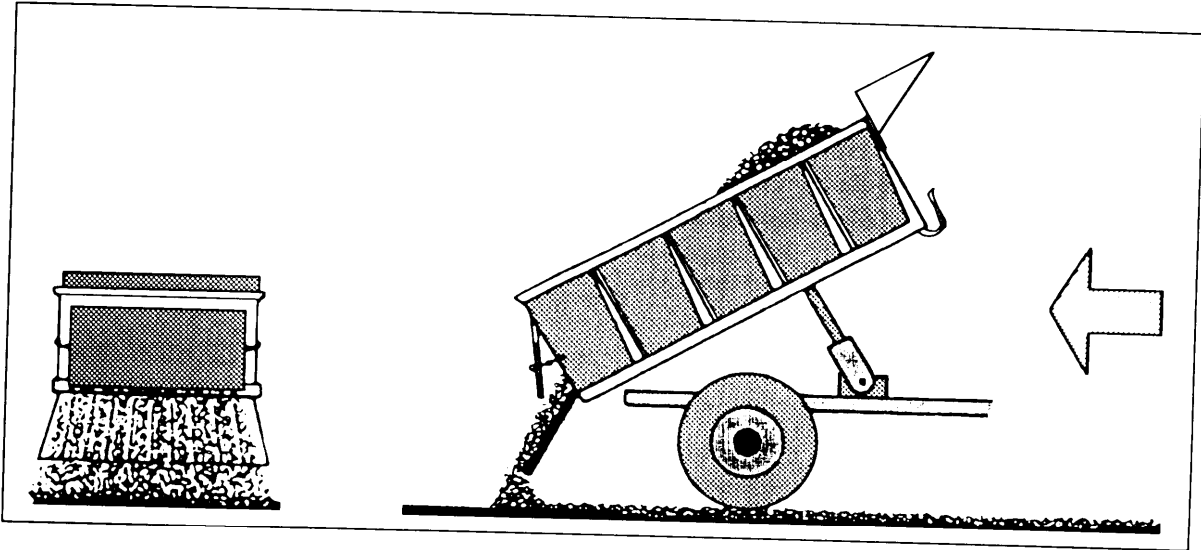

Figure 16-29.—Vane spreader.

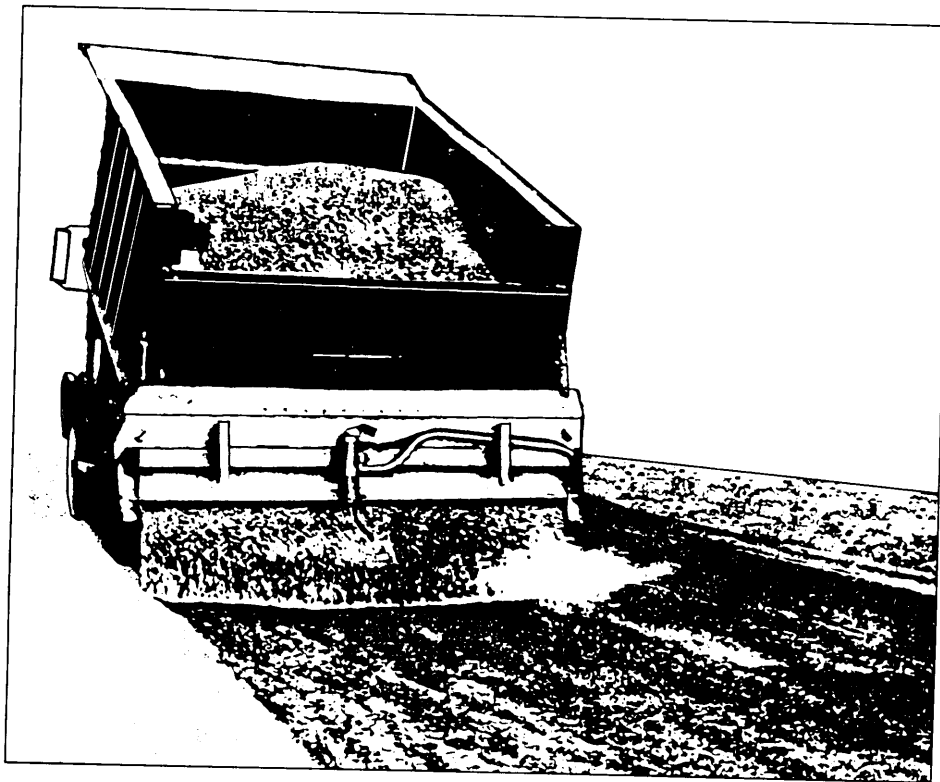

Figure 16-30.-Hopper type of tailgate spreader.

A self-propelled spreader is shown in figure 16-31. This machine moves forward and makes possible a uniform and continuous application of cover aggregate, because it is capable of keeping up with the asphalt distribute. The spreader is self-powered and has a receiving hopper in the rear. Aggregate trucks are hitched to the spreader, dump their loads into the hopper, and are pulled by the spreader. Belt conveyors carry the aggregate to the front of the machine where it is dropped into the spreading hopper (fig. 16-32). Aggregate flows over a spread roll onto a screen that permits initial placement of larger particles on the asphalt, followed by fine aggregate on top.

Calibration and adjustments for all types of aggregate spreaders should be made according to the

manufacturer's instruction and operating manual. Here are some additional checks that should be made to ensure good results:

1. A tachometer, used as an aid in maintaining uniform spreader-box speed, is most helpful.
2. Distribution rates are closely controlled by measuring off the length that each truckload of aggregate should cover.
3. A quick check on the rate of application of aggregate can be made by laying a 1-square-meter (yard) section of cloth or building paper on the pavement (or by supporting a shallow 1-square-yard box above the asphalt with nails or screws) and by passing over it with the spreader. The cloth, paper, or box is then carefully

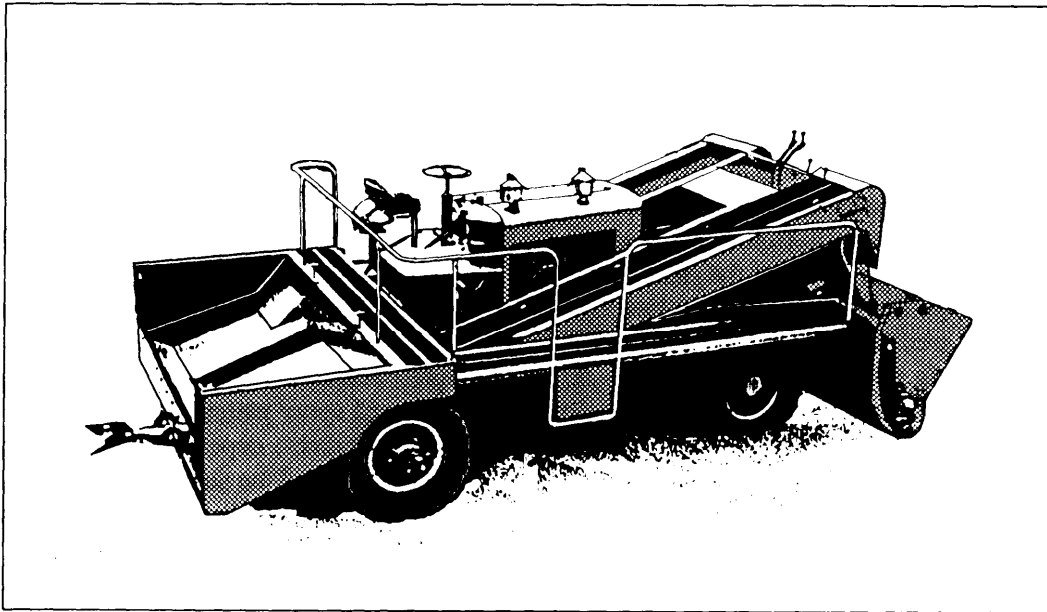

Figure 16-31.—Self-propelled aggregate spreader.

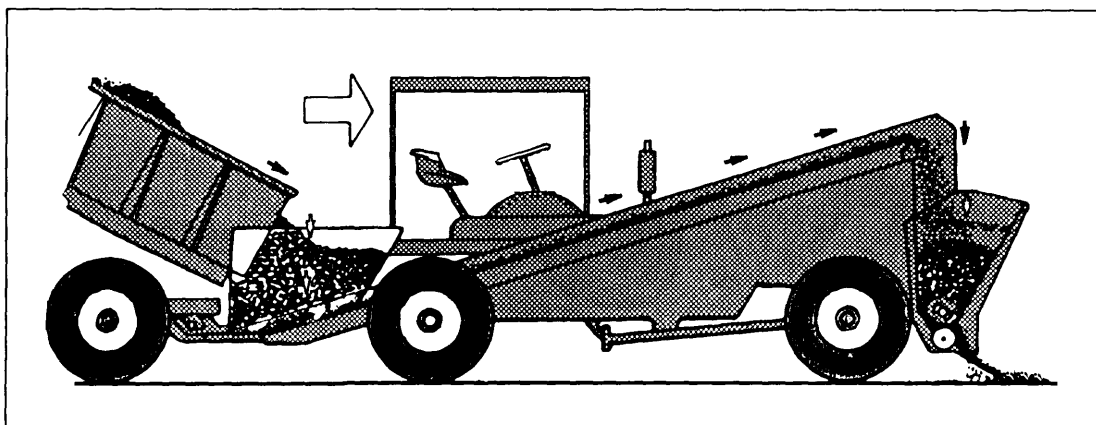

Figure 16-32.—Flow of aggregate through a self-propelled aggregate spreader.

lifted and the aggregate on it is weighed. This will give the weight per square yard of aggregate being spread.

ASPHALT DISTRIBUTOR

The asphalt distributor (fig. 16-33) is a unit consisting of an insulated storage and heating tank, an open flame heating system, an asphalt pump, a low-pressure air blower, and a circulating and spraying system. Power to operate the components is PTO driven.

NOTE: The operation of this truck requires the absolute need for experienced personnel only. Mishaps, resulting in loss of man-days and equipment, are a direct result of this factor being overlooked.

Heating System

The air blower provides low-pressure air to atomize fuel for the burners. The burners heat the tubes, located in the tank. An asphalt covering must be maintained over the fire tubes to prevent them from overheating and causing a fire or explosion. Because the distributor is mobile, care must be taken to ensure that heating is performed in a level area that is well-ventilated and that the distributor truck is not moving at all and is at a COMPLETE HALT. Whenever you are heating cutbacks, the asphalt must be circulating at all times. This is a must to prevent any chance of volatile liquids overheating around the flues, which can be very dangerous.

Spray System

The spray system consists of necessary piping, a series of hand-operated valves to control the flow of bitumen, and an adjustable length spray bar, capable of providing coverage from 4 to 14 feet wide. The spray bar may be the full-circulating or the noncirculating type, depending on the model of the distributor. The spray bar may be equipped with either 1/8-inch nozzles or 3/8-inch nozzles; the 1/8-inch nozzles are used for most applications. The application rate is controlled by the length of the spray bar, the pump output, and the forward speed of the distributor truck.

Spray Bar Adjustments

For normal use, the spray bar of the distributor should be adjusted, so the vertical axes of the nozzles are perpendicular to the roadway. Also, each nozzle on the spray bar should be set at the same angle. The angle set for each should be between 15 degrees to 30 degrees of the horizontal axis of the spray bar (fig. 16-34) or according to manufacturer's specifications. This action prevents the fan-shaped spray patterns of the nozzles from interfering with each other.

Another adjustment that is essential for uniform prime or tack coat coverage is the adjustment of the height of the spray bar. As shown in figure 16-35, the fan-shaped spray patterns from the nozzles overlap to different degrees, depending on the distance between the spray bar and the surface to be covered. The spray bar should be set high enough, usually 10 to 12 inches above the roadway for the surface to receive triple

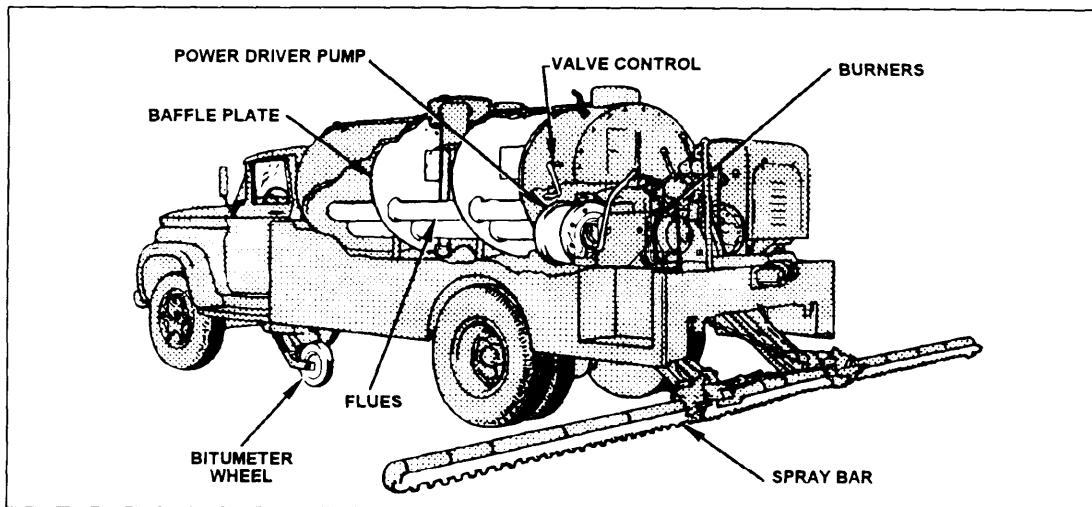

Figure 16-33.-Asphalt distributor.

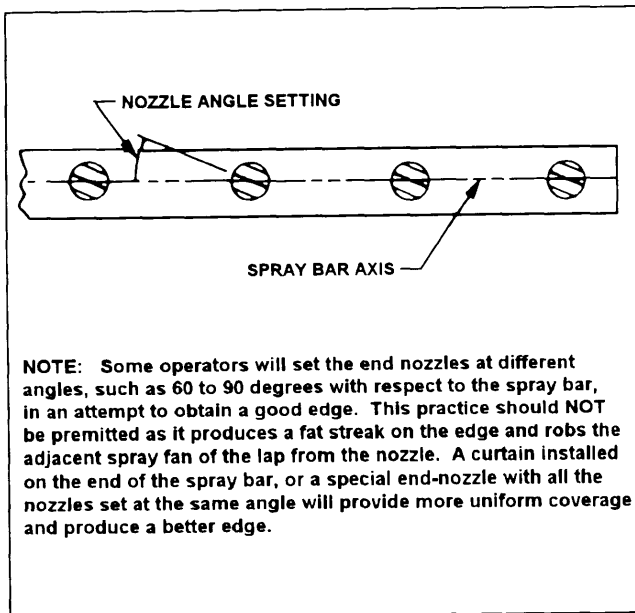

Figure 16-34.-Proper angling of nozzles.

coverage. This height varies according to the nozzle spacing of the spray bar. Under heavy wind conditions or depending on the nozzle spacing, it may be necessary to lower the bar farther down so that the surface only receives double coverage.

On some distributors, as asphalt is sprayed (and the load lightens), the truck rear springs of the truck rise, raising the distributor and changing the height of the spray bar. Mechanical devices are usually available that

automatically correct the height of the spray bar, as this change occurs.

The uniform application of asphalt prime and tack coat is essential. Transverse spread should not be allowed to vary more than 15 percent, and the longitudinal spread should not vary more than 10 percent. To ensure the correct application, you must calibrate the distributor before it is used. Then the transverse and longitudinal spread rate variations should be checked periodically to determine when the distributor is operating within these limits. A procedure for checking these spread variations in the field has been standardized by ASTM D 2995, published by the American Society for Testing and Materials.

FILLING TANKS AND DISTRIBUTORS.—

Always use a manhole strainer when filling tanks and distributors unless you are filling them with emulsions. When you do not want material to enter the pump and circulating system, ensure the intake valve lever is in the UP position. When the tank is full of hot bitumen that may set upon entering a cold pump, you should heat the pump and circulating system before starting to circulate the bitumen to prevent it from freezing in the pump. A portable burner is available to use if the pump is cold.

When you are filling lines using a pump, always use a strainer in the filling line except when using emulsions. Be sure that all connections between the distributor and source of supply are tight. Because air leaks reduce vacuum and slow down the heavier bitumens, it may be

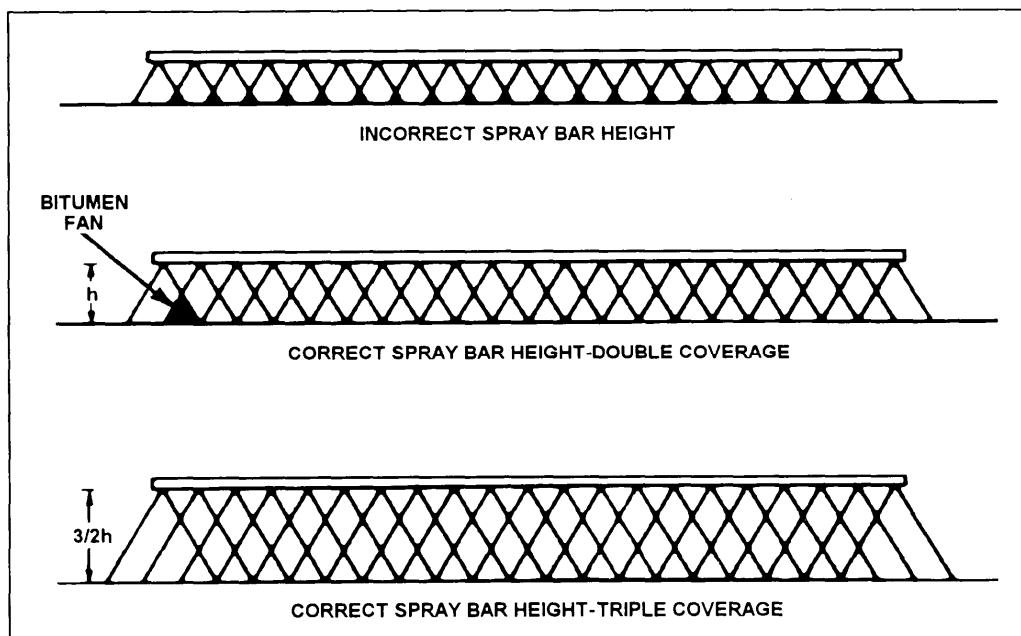

Figure 16-35.-Spray bar height and coverage.

necessary to preheat the circulating system to ensure that the first material to enter the pump is not to be chilled sufficiently to stop the pump. A portable burner is available for this purpose. An opening in the circulating system housing at the rear, near the bottom of the housing, is provided for the burner.

Normally, 150 gallons per minute (gpm) is the best loading speed. Light materials or heavy materials at spraying temperature may be loaded at faster pump speeds. Check the filling line as well as the pump discharge strainer periodically and clean as needed.

When the distributor is to be filled with hot bitumen, proceed cautiously if there is any moisture in the tank or if emulsion was used in the previous load because foaming could occur. A liquid compound, Dow Corning DC-200, can be used to prevent foaming.

HEATING BITUMEN IN THE DISTRIBUTOR.— When you are heating bitumen in a distributor with low-pressure atomizing burners, using clean, moisture-free fuel is important; therefore, use kerosene, fuel oil, or diesel fuel. **DO NOT USE GASOLINE.** To start the blower, disengage the engine clutch, engage the blower drive clutch, then engage the engine clutch.

Air pressure should be sufficient to raise the air relief valve slightly. Excessive engine speed will raise the relief valve too much. The correct air pressure to use is 1 1/2 to 2 psi.

Fuel pressure should not be excessive. High fuel pressure will make the needle valve adjustments more sensitive. The correct fuel pressure to use is 10 to 20 psi. Pressure is determined by a relief valve, located under the fuel tank. An adjusting screw and locknut are inside the dome-shaped cap.

Do not light the burners unless you are sure the flues are covered with 6 inches of material the full length of the tank. On tanks having high-low flues, it is necessary to cover only the lower flue when using the lower burner. Open the stack cover.

To light the burners, you should turn the air butterfly valves to the START position, light the torch, and hold it under the burner tip. Then turn the valve about one-half turn. The burner should ignite immediately. If it does not, turn off the needle valve and wait until the gas is exhausted from the flues, then try again.

NOTE: The correct amount to turn the needle valve is determined by the fuel pressure. Experience is the only way you can determine the correct amount for a particular unit.

At first, the flame will be yellow and smokey. Adjust the fuel valve so that the flame is bright orange with slight color in the exhaust. More adjustment to the fuel will be needed as the flues and tank contents heat up.

WARNING

When the burner goes out, you should turn off the fuel valve immediately and do NOT attempt to relight until the gas vapors are exhausted from the flues.

For larger flames, increase the air butterfly valve opening and the fuel valve opening in equal increments. Always keep a mix that produces an exhaust that has a slight color. The nozzle of the burner is adjustable for the amount of secondary air desired. Light the burner and turn this nozzle until you secure the type of flame you desire. Further adjustment is not necessary. Do NOT leave the burners unattended. Do NOT heat to a temperature over the maximum spraying temperature recommended by the supplier. To shut off the burners, turn the fuel off before stopping the blower or turning off the air.

Spraying

Correct spraying cannot be obtained unless the bitumen is heated to the proper spraying temperature. When using 1/8-inch nozzles, set the governor from 120 to 180 gpm for a 12-foot spray bar. In the NCF, a rule of thumb for GPM is 10 gallons per minute for every foot of bar length. Example: 10-foot bar length = 10 GPM. Higher pump speeds cause excessive fogging of the spray. Lower pump speeds cause the bitumen spraying fan, as shown in figure 16-33, to sag with heavy edges. Also, when the fans have heavy edges, the cause could be that the material is too cold or the pump speed is too slow.

At the end of the day, be sure to flush out the pump and circulating system. Performing this easy draining and cleaning operation prevents the pump and circulating system from clogging up because of bitumen setting up and hardening in the system.

Attachments

Some areas cannot be reached with the spray bar; therefore, it is sometimes necessary to apply asphalt by another means. In such cases, spraying can be done by hand with a spray hose and gun, as shown in figure

16-36. This equipment must be operated following the instructions, given in the manufacturer's manual.

Suggested Spraying Temperatures

Suggested spraying temperatures are given in table 16-3 for various types and grades of asphalts commonly used for prime coating and tack coating.

WARNING

Application temperatures may, in some cases, be above the flash points of some

materials. Care must be given to prevent fire or explosion. The maximum temperature (cutback asphalt) shall be below that at which fogging occurs.

Below are the formulas used for distributor truck operations.

To compute gallons per minute (GPM):

$$GPM = \frac{L \times \text{Bar Width} \times ROA}{9}$$

Table 16-3.-Suggested Spraying Temperature Ranges for Prime and Tack Coat

Type and Grade of Asphalt	Temperature
SS-1	70°F - 160°F
SS-1h	
CSS-1	70°F - 160°F
CSS-1h	
MC-30	85°F+
MC-70	120°F+
MC-250	165°F+

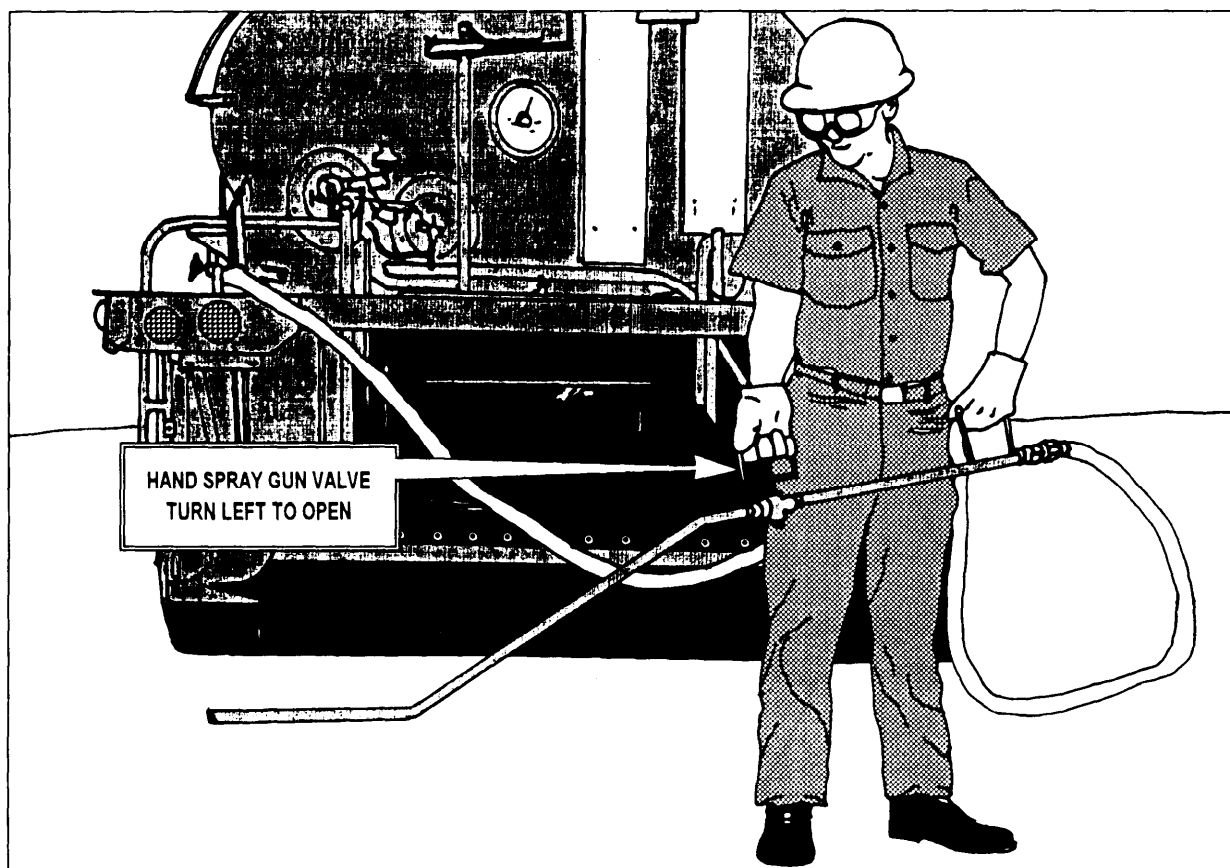

Figure 16-36.-Hand-spray application.

To compute truck application speed in feet per minute (FPM):

$$FPM = \frac{9 \times GPM}{Bar\ Width \times ROA}$$

To compute truck application speed in miles per hour:

$$MPH = \frac{9 \times GPM}{88 \times Bar\ Width \times ROA}$$

To compute the length of spread in feet:

$$L = \frac{9 \times T}{W \times ROA}$$

Where

L = Length of spread in feet

T = Total gallons in distributor

W = Sprayed width of roadway in feet

ROA = Rate of application in gallons per square yard.

ASPHALT KETTLE

The asphalt kettle shown in figure 16-37 is equipped for hand-spraying bituminous materials for dressing stretches of road or runway shoulders, filling surface cracks, and spray-coating areas for asphalt repairs, surface treatment, or seal coating.

The trailer-mounted tank consists of an outer shell with a 165-gallon capacity storage and melting tank

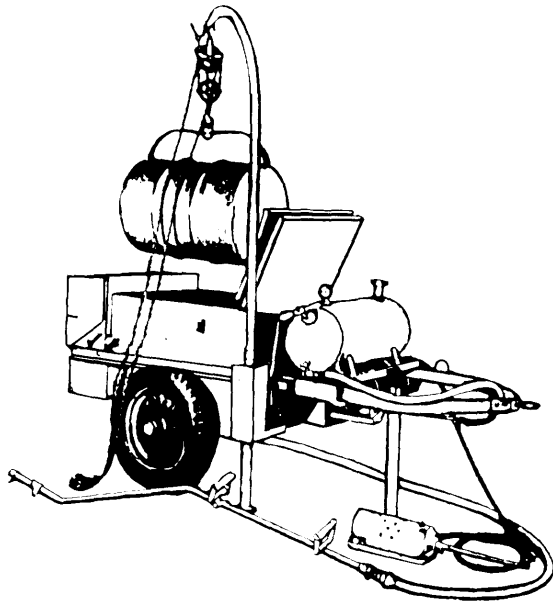

Figure 16-37.—Asphalt kettle.

mounted inside. A removable fuel burner, mounted inside the kettle outer shell, provides heat to the melting tank through a baffle. A flue stack located on the forward end of the melting tank over the top of the baffle and burner assembly, provides an escape for exhaust gases. A thermometer, inserted through an insulated pipe into the interior of the melting tank indicates the temperature reading of the bituminous material being heated. When the bituminous material is overheated, a fire or explosion can result.

A two-cylinder gasoline engine provides power for the bitumen pumping system. When you shift the clutch shifter lever, the engine is engaged to the pump assembly that provides the pressure for all pumping operations. A flexible, metal spray hose, which connects the pump to the hand-held spray bar assembly, is used to convey bitumen to the surface being repaired.

SAFETY PRECAUTIONS

Safety precautions for the distributor truck and asphalt kettle operations are as follows:

- Always have dry chemical type of extinguishers available and in good condition.
- Check all body mounting tie-downs and fasteners. On trailer units, check kingpin plate fasteners and all suspension and running gear components.
- Lighted cigarettes or other sources of combustion must be kept clear of open manholes or overflow vents to reduce fire hazards.
- Sparks from the engine exhaust can be for the ignition of volatile gases.
- Remain clear of rotating drives when the unit is in operation to prevent becoming entangled in the machine.
- Use goggles and gloves or insulated material when handling the spray bar, sections, or hoses to prevent burns.
- Monthly, check (and if necessary clean) the 3-inch overflow tube to ensure that the tube is not clogged.
- Open a manhole slowly to relieve any pressure that may exist in the tank.
- Check and ensure that all pipe and hose connections are secure before operating valves to eliminate leaks (that may spray hot bitumen on other personnel).
- Keep the unit clean for safety and operation.

- Keep the area clear of open flame or sparks to reduce fire hazard when you are spraying material with volatile cutbacks.

- Do not stand in a location in which the accidental opening of the spray bar valves will cause contact with the bitumen spray. This is important, because you could receive serious burns if you do not.

- The fill line cap or connection must be securely attached before operating the intake valve lever to eliminate momentary discharge.

- The “TUC” bar must be off and remain off when the bar is rotated upward.

- When moisture is present in the tank, do not load the tank with material having a temperature over 200°F. To prevent foaming when filling a unit in which moisture may be present in the spray bar or the circulating system, you should allow a small portion of hot material to circulate in the spray bar before filling the tank.

- When you are heating material, if at all possible, position the unit broadside to the wind.

- The use of gasoline instead of regular kerosene or fuel oil on low-pressure burners will result in an extreme fire hazard.

- Do not operate burners unattended (unless a safety control is provided) or while the vehicle is in transit or in a confined area.

- When heating, you must allow sufficient space in the tank for expansion of the material.

- To prevent a possible explosion, you must cover flues with at least 6 inches of bitumen before heating the material. This layer of bitumen reduces the vapors produced, thereby, reducing the chance of an explosion.

- For personal safety, use a torch (not a match or lighter) to ignite the burner.

- Ignite the inside burner first. Do not reach across a lighted burner to ignite the inside burner.

- When burners go out, allow time for ventilation before re-ignition.

- Do not heat material beyond the manufacturer's recommended temperature.

- When you are hand spraying, hold the sprayer in the proper position and be aware of other personnel in the area.

- Emulsified asphalts should never be left in the distributor truck for any great length of time. Emulsified asphalts will separate and set in much less time than will cutbacks.

- Avoid inhaling the vapors or mist from sprayed asphalt, or prolonged skin contact with asphalt products. Asphalt materials contain compounds known or suspected to cause cancer. Hot asphalt is a burn hazard and can cause serious eye damage.

ASPHALT HAUL TRUCKS

Various types of trucks are used to deliver hot mix to the paver. The most common type is the 5-ton end-dump truck but other trucks have been used and can be used to deliver mix.

Truck Condition

Trucks must have metal beds, and the beds must be clean, smooth, and free of holes. All trucks must meet minimum safety criteria. Each truck must be clearly numbered for easy identification and must be equipped with a tarpaulin.

Before being loaded, the truck bed must be cleaned of foreign material and hardened asphalt and then lightly coated with a release agent (lubricant) that assists in preventing fresh hot-mix asphalt from sticking to the surfaces of the bed. After the bed is coated, any excess release agent must be drained from the bed. Before loading, the truck must also be weighed to establish its unloaded weight. This weight is later subtracted from the loaded weight of the truck to determine the weight of the hot mix that the truck is hauling.

The number of trucks required on the project is determined by many factors: the mix production rate at the plant, the length of the haul, the type of traffic encountered, and the expected time needed for unloading.

Types of Trucks

Each type of truck used for hot-mix delivery must have certain physical features that are required to haul properly and to discharge the mix properly into the paver. Below are listed a few guidelines for the two most common types of trucks.

END-DUMP TRUCKS.— An end-dump truck must first be inspected to be certain the rear of the bed overhangs the rear wheels enough to discharge mix into the paver hopper. If it does not, an apron with side plates must be added to increase the overhang and prevent spillage of the mix in front of the paver.

The bed must also be of a size that will fit into the hopper without pressing down on the paver. The

hydraulic system for the truck-bed hoist should be frequently inspected to guard against hydraulic fluid leakage. Such leakage on the roadway surface will prevent good bonding between the roadway and the new mat. When enough oil is spilled that the mix can absorb it, the mix can become unstable at that spot. For this reason, leaking trucks should not be used.

Tarpaulins should be pulled over the mixture during hauling in cool weather or on long hauls to protect the mixture from excessive cooling. A cool mix forms lumps and a crust over its surface. When a tarpaulin is used, care must be taken to be sure it is securely fastened to the top of the truck bed so that cold air cannot funnel under it.

During delivery, the driver must direct the truck squarely against the paver and should stop the truck a few inches from the paver before the truck tires make contact with the paver roller bar. Backing the truck against the paver can force the screed back into the mat, leaving a bump in the pavement even after the mat is rolled.

The truck bed must be raised slowly. When the mix is dumped too rapidly, segregations occur, because the coarser aggregates will roll down the sides of the load.

BOTTOM-DUMP TRUCKS.— Bottom-dump trucks can be used when a grader is spreading the mix or when a pickup device is used to feed the windrow left by the truck into the paver hopper.

Two common methods for unloading bottom-dump trucks are in use. The first method involves the use of a spreader box, designed to be operated under the gates of the truck. The amount of material, placed in the windrow, is governed by the width of the spreader box opening. The disadvantage of this method is that the spreader box can restrict the amount of material to less than the required amount. The second method, which is used more often than the first, is to use chains to control the dump gate opening.

NOTE: Automatic devices are also available for controlling gate openings.

Variations in the size of the windrow, deposited by the bottom-dump truck for pickup by the paver, and irregularities in the surface on which the material is to be placed will cause variations in the amount of material fed to the paver hopper. This often causes variations in the finished surface. It is, therefore, essential that the windrow, deposited by the truck be as uniform as possible. When the windrow is deficient in size, material can be added to it to keep the paver from starving. When the windrow contains too much mix, a short gap in depositing with the next truck will

compensate for the excess. The windrow length must also be controlled particularly in cool weather. Windrowed material will cool below spreading and compaction temperatures in cool weather, particularly when delay occurs because of paver malfunction. The limit of the windrow should be no more than one truck load ahead of the pickup machine to prevent excessive cooling of the mix in cold weather.

When the loader and paver are directly coupled, vibration of the pickup device maybe transmitted into the paver, causing ripples and roughness in the mat surface. These vibrations generally result from worn and defective parts or from improper mounting or adjustment.

Truck Hitches

The purpose of a truck hitch on the front of the paver hopper is to keep the truck dumping hot mix into the hopper in contact with the paver. If, during dumping, the truck and the paver separate and hot mix spills, it must be cleaned up before the paver passes over it.

Two types of truck hitches are in common use. One type uses an extension that reaches under the truck and hooks onto the rear axle of the truck. The other type of hitch has retractable rollers that are attached to the truck push bar and grip the outer side of the rear wheels of the truck. The rollers revolve with the wheels while the truck dumps its load into the hopper.

Pivoted Truck Push Rollers

The pivoted push roller is a device, mounted on the front of the paver, that adjusts when alignment between the truck and paver is uneven. This device reduces the uneven force exerted on the paver by the misaligned truck, minimizing interference in the steering of both vehicles.

ASPHALT FINISHERS (PAVERS)

Various makes and models of asphalt finishers are used by the Naval Construction Force (NCF). Two types are shown in figure 16-38. Even though the finishers may operate differently, their primary jobs are all the same: receiving asphalt and spreading it in a predetermined, uniform length, width, thickness, and shape. The finisher also provides initial compaction of the mat (layer of mixture in place.)

Because asphalt finishers are different, you must always read the operator's manual for the unit you are operating. It is also good to have a practice sand laydown before actually using a hot mix. This is to familiarize yourself and others with the machine and also ensure that the machine is working properly. Figure 16-39 shows a practice laydown, using just the aggregate mix without the asphalt.

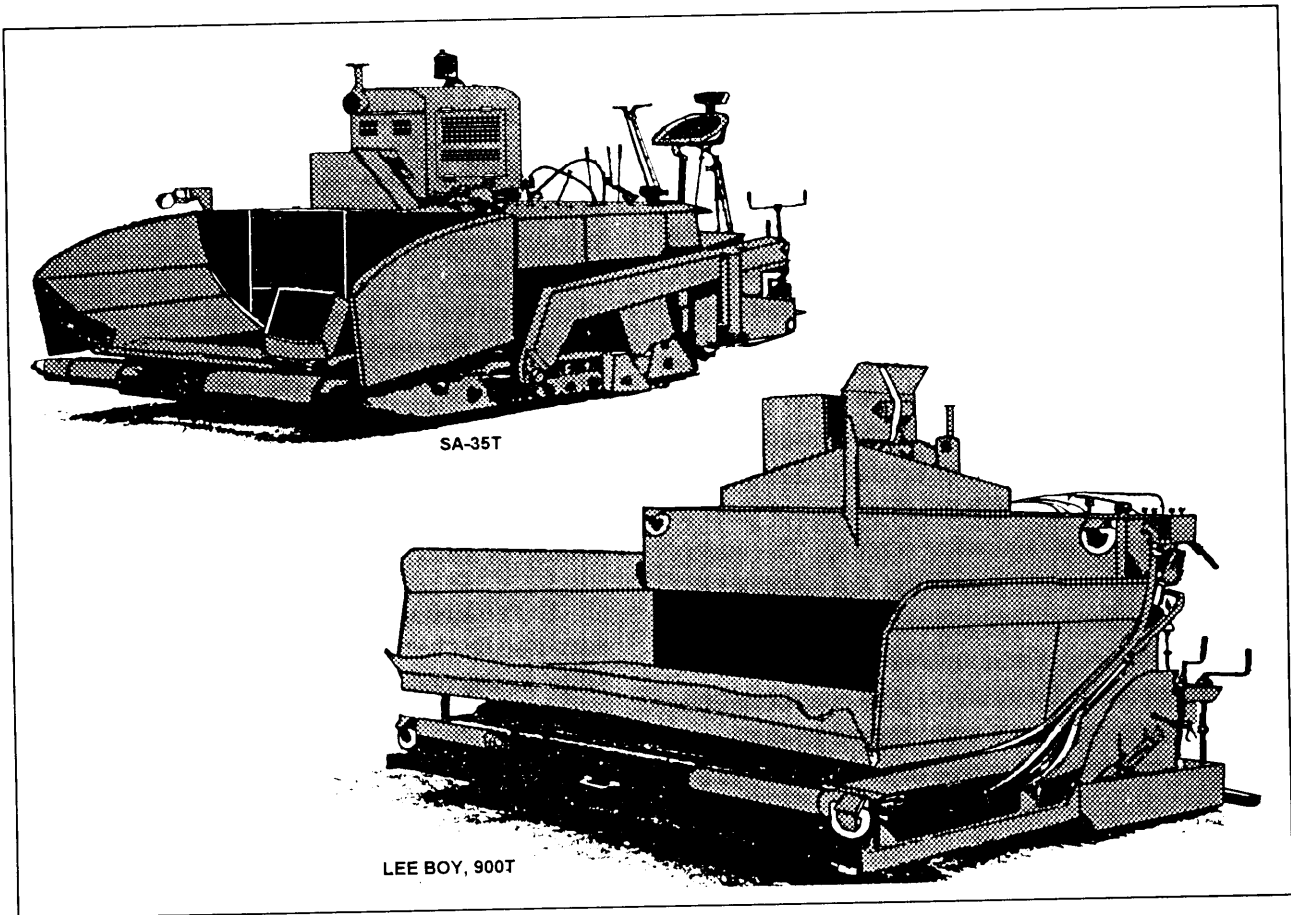

Figure 16-38.-Two common types of asphalt finishers.

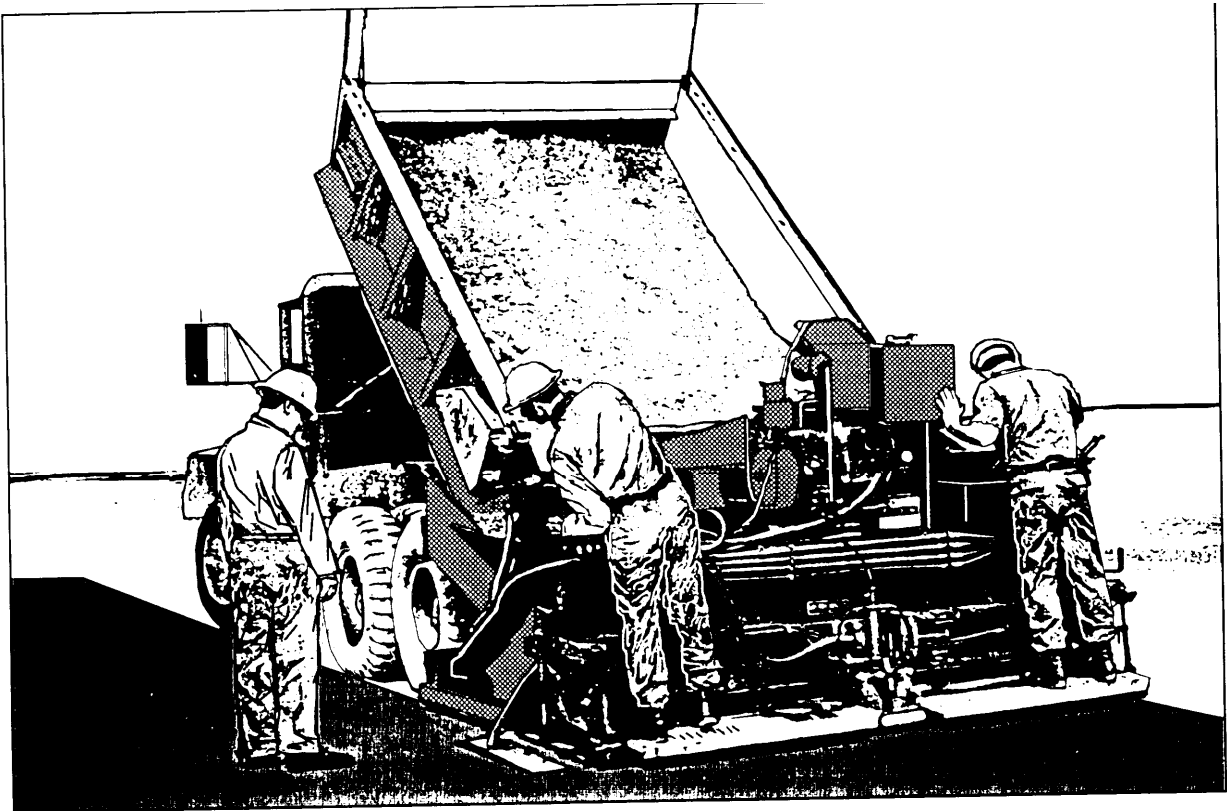

Figure 16-39.—Practice laydown.

Tractor Unit (Power Unit)

The tractor unit provides moving power for the paver wheels or tracks and for all powered machinery on the paver. The tractor unit includes the receiving hopper, feed conveyor, flow control gates, distributing augers (or spreading screws), power plant (engine), transmissions, dual controls, and operator's seat.

The tractor unit power plant (engine) propels the paver, pulls the screed (leveling) unit, and provides power to the other components through transmissions. Hot mix is deposited in the hopper and is then carried by the feed conveyor through the flow control gates to the distributing augers (spreading screws). The augers distribute the mix evenly across the full width of the paver, thus providing uniform placement of the mix onto the roadway surface. These operations are controlled by the paver operator by means of dual controls within easy reach of the operator's seat. Figure 16-40 shows the operating controls of one type of finisher used in the NCF.

To ensure the paver functions properly, you should inspect the paver before commencement of paving. Below are some of the components you should check.

PAVER TIRES OR TRACKS.— When the paver is equipped with pneumatic tires, tire condition and air pressure must be checked. It is particularly important for the pressure to be the same in the tires on both sides of the paver. When the paver moves on tracks (crawlers), the tracks should be checked to be certain they are snug but not tight, and the drive sprockets should be checked for excessive wear. Low tire pressure or loose tracks can cause unnecessary movement of the paver, which is transmitted to the screed unit, resulting in an uneven pavement surface. There should be no buildup of material on the tires or on the tracks.

GOVERNORS.— The governor on the engine must also be checked to be sure that there is no periodic surge in the engine rpm. When the governor is not working properly, there can be a lag in power when the engine is loaded (strained). Such a lag causes temporary failure of the vibrators or tamping bars in the screed unit, resulting in a stretch of pavement that is less dense or

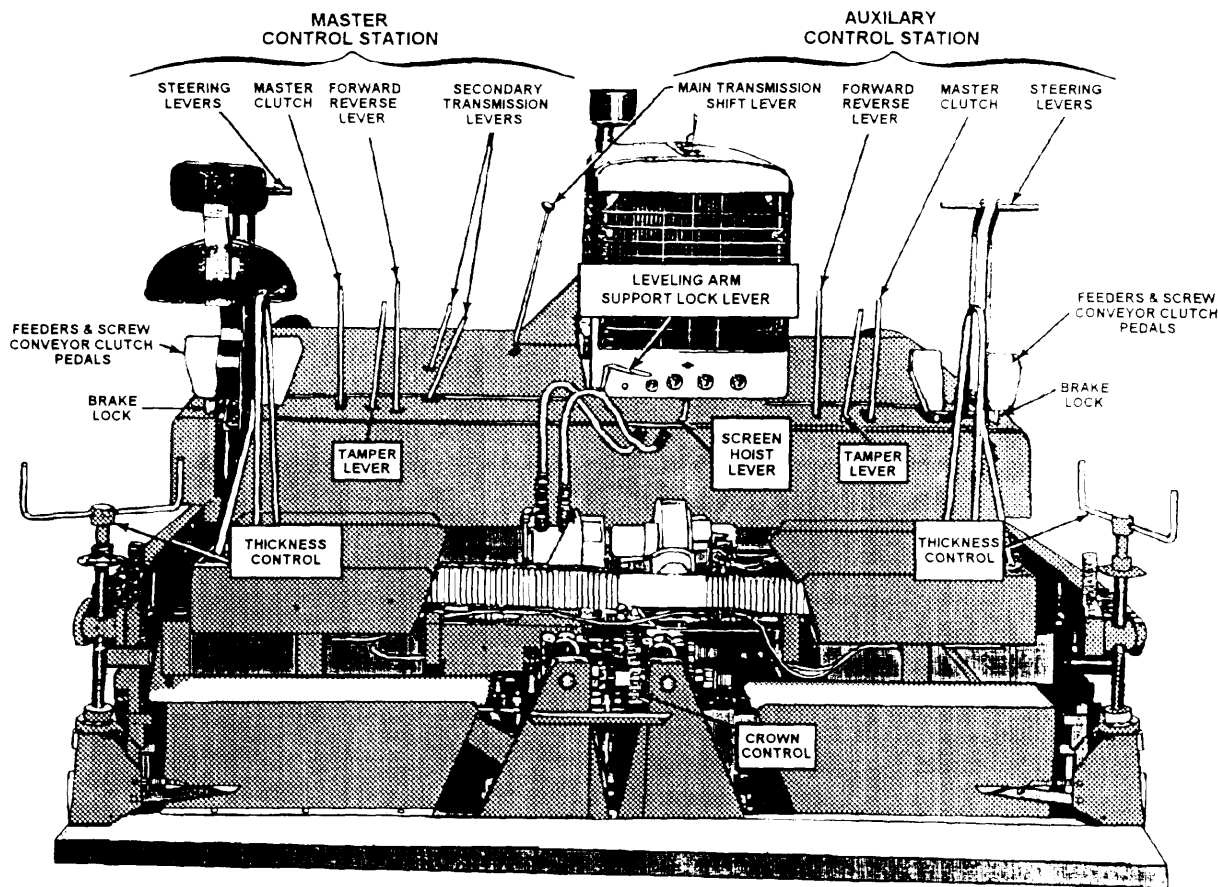

Figure 16-40.-Operating controls, Barber-Greene model SA-35 finisher.

contains slightly less material than the immediately adjacent area. After rolling, you can see that an area shows up as a transverse ripple in the pavement. A power lag can also interfere with the smooth and consistent operation of the electronic screed controls.

HOPPERS, FLOW GATES, AND AUGERS.—

The hopper, the slats on the feed conveyor, the flow gates, and the augers should be checked for excessive wear and observed to be certain they are operating properly. Necessary adjustments should be made to ensure that these components are functioning as designed and are able to deliver a smooth flow of mixture from the hopper to the roadway. This includes adjustments to any automatic feed controls.

The speed of the conveyor and the opening of the control gates at the back of the hopper should be adjusted, so just enough mixture is being delivered to

the augers to keep the augers operating about 85 percent of the time. This allows a uniform quantity of mix to be maintained in front of the screed. When additional mix is required to allow an increase in the thickness being placed, the flow control gates should be adjusted. Augers should be kept about three-quarters full of mixture during paver operations.

Screed Unit

In operation, the screed is pulled along behind the tractor unit. The long screed pull-arms are pivoted that permits the screed to have a floating action, as it travels along the road. As the tractor unit pulls the screed into the mix, the screed seeks the level that allows the path of the screed to be parallel to the direction of pull. At this level, all of the forces, acting on the screed, are in balance, as the paver moves down the road. The screed plate irons the surface of the mixture, leaving the mat thickness at a depth that conforms with job specification. Mat thickness and crown shape are regulated by screed controls. Tamping bars (fig. 16-41) or vibratory attachments then compact the mat slightly in preparation for rolling. Figure 16-42 shows the workings of a screed.

Attaining proper mat thickness is a matter of balancing the forces, as shown in figure 16-42, with one another.

1. To maintain forward motion of the screed, force P must be greater than force H.

2. To increase the thickness of the mat, tilt the screed plate so that more material is crowded under the screed plate. The screed will rise until the finished surface is again in a plane parallel to the direction of pull.

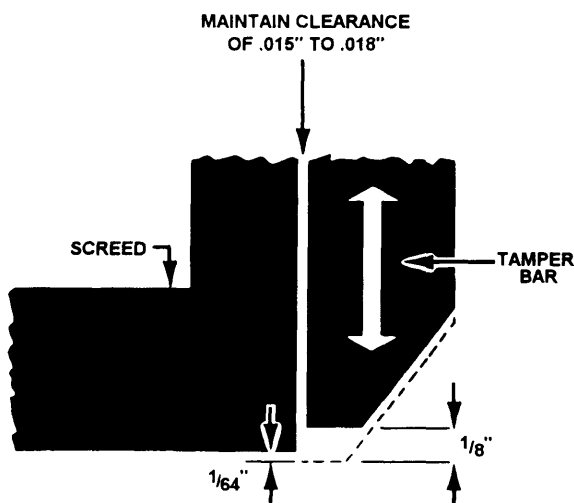

Figure 16-41. Tamping bar.

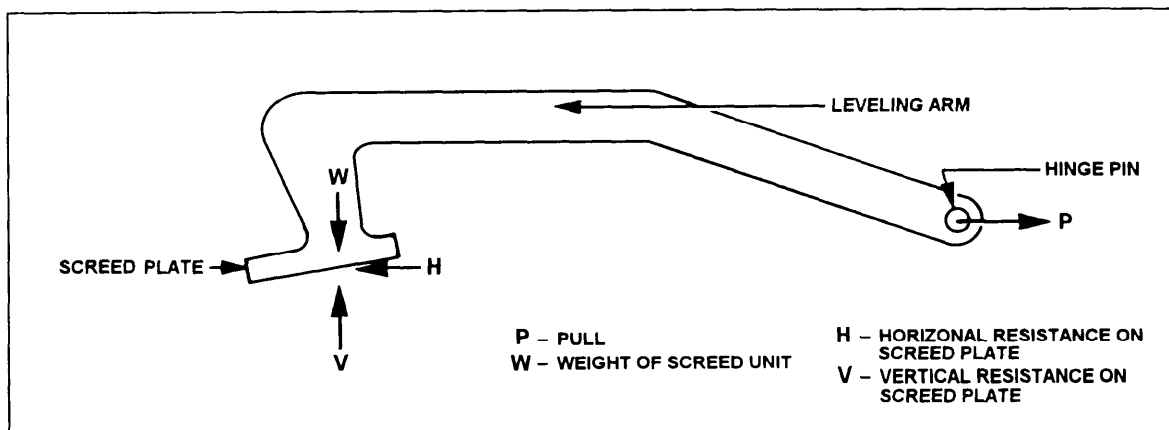

Figure 16-42. Forces acting on the screed.

Force V will decrease at this point and be balanced by force W.

3. To reduce mat thickness, tilt the screed plate so that less material crowds under the screed plate.

4. The amount and condition of the material, leaving the auger, can change the equilibrium of the four forces. Excessive flow of material increases force H. A cold, stiff mix will increase H and to some extent V. An excessively hot, fluid mix decreases H and V. Stopping and starting the paver also cause changes in equilibrium among the forces. The key to controlling the action of the screed is to maintain in a uniform manner those forces acting on the screed.

5. The secret of good paver operations is a balance of the forces and uniformity to maintain that balance. When balance and uniformity are attained, the screed path follows the paver in a plane parallel to that of the pivot point. As the paver goes up over an irregularity, the pivot point rises and the screed begins to rise also. However, because the screed reacts to changes in elevation more slowly than the pivot point does, the screed rises very little and thereby maintains the plane of the surface of the mat over the irregularity, and the impact of the irregularity is reduced. The same is not true of long irregularities (longer than several lengths of the paver). Grade line irregularities of this type should be corrected before placing surface courses with the paver.

6. Screeds, equipped with tamping bars and vibratory mechanisms, are designed to strike off and then compact the mixture slightly, as it is placed. The two purposes for this screed action are that it achieves maximum leveling of the mat surface and ensures that minimum distortion of the mat surface occurs with subsequent rolling.

TAMPING BAR TYPES OF SCREEDS—

Tamping bar types of screed compactors compact the mix, strike off the excess thickness, and tuck the material under the screed plate for leveling. As figure 16-41 shows, the tamper bar has two faces:

- A beveled face on the front that compacts the material, as the screed is pulled forward.
- A horizontal face that imparts some compaction, but primarily strikes off excess material, so the screed can ride smoothly over the mat being laid.

The adjustment that limits the range of downward travel of the tamping bar is the single most important adjustment affecting the appearance of the finished mat. At the bottom of its stroke, the horizontal face should

extend one sixty-fourth of an inch (about the thickness of a fingernail) below the level of the screed plate. When the bar extends down too far, mix builds upon the screed face. This buildup scuffs the surface of the mix being placed and also causes the tamping bar to lift the screed slightly on each downward stroke, and this often causes rippling of the mat surface.

When the horizontal face of the tamping bar is adjusted too high (either by poor adjustment or due to wear of the bottom of the horizontal face), the bar does not strike off excess mix from the mat. Consequently, the screed plate begins to strike off the material, and this results in surface pitting of the mix being placed because the leading edge of the screed plate drags the larger aggregates forward. For this reason, the tamper bar should always be checked before operating the paver, and it should be adjusted if necessary. Before the tamper bar approaches knife-edge thinness, it should be replaced.

VIBRATING TYPES OF SCREEDS.— The operation of vibratory screeds is similar to that of tamping screeds, except that the compactive force is generated either by electric vibrators, rotating shafts with eccentric weights, or hydraulic motors (fig. 16-43).

On some pavers both the frequency (number of vibrations per minute) and the amplitude (range of motion) of the vibrators can be adjusted. In others, the frequency remains constant and only the amplitude can be adjusted. Frequency and amplitude must be set according to the type of paver, the thickness of the mat, the speed of the paver, and the characteristics of the mixture being placed. Once set, the frequency and amplitude do not normally need adjustment until the mat thickness or mix characteristics change.

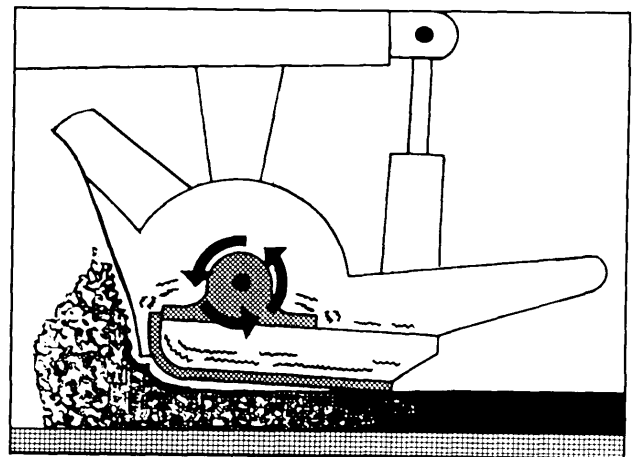

Figure 16-43. Vibratory type of screed.

Some vibratory screeds require a pre-strike-off unit. This unit is a rounded moldboard that controls the amount of mix passing under the screed.

SCREED CONTROLS (ADJUSTMENTS).—

In operating the screed, two types of controls are essential:

- Control of the thickness of the mat
- Control of the crown, formed in the mat for proper drainage

Both functions are regulated by controls built into the paver (fig. 16-44).

It is important to understand that, when the paver is operating, control adjustments, made to the screed, take time to go into effect. For example, when a thickness control screw is adjusted to change the thickness of the mat, the paver is likely to move a distance of several feet before the change is completed, and the mat is produced in the new thickness. For this reason, it is necessary that a screed

operator know the effective delay involved in making adjustments to a particular screed unit and be able to anticipate adjustments accordingly. Furthermore, it is important that after such adjustment of the thickness controls, the paver be allowed to travel far enough for the correction to be completed before another adjustment is made. Excessive adjustment or overcontrol of the thickness controls is one of the principal contributors to poor pavement smoothness.

The condition of the screed unit is important when a high-quality mat is to be placed. To ensure the screed control linkage is snug, the operator should check the wear points. Also, the screed plates should be checked regularly for signs of wear, such as pitting and warping. The plates should always be properly adjusted before paving begins. Both the leading and trailing edges of the screed have a crown adjustment. The leading edge should always have slightly more crown than the trailing edge. This provides a smooth flow of material under the screed. Too much lead crown results in an open texture along the edges of

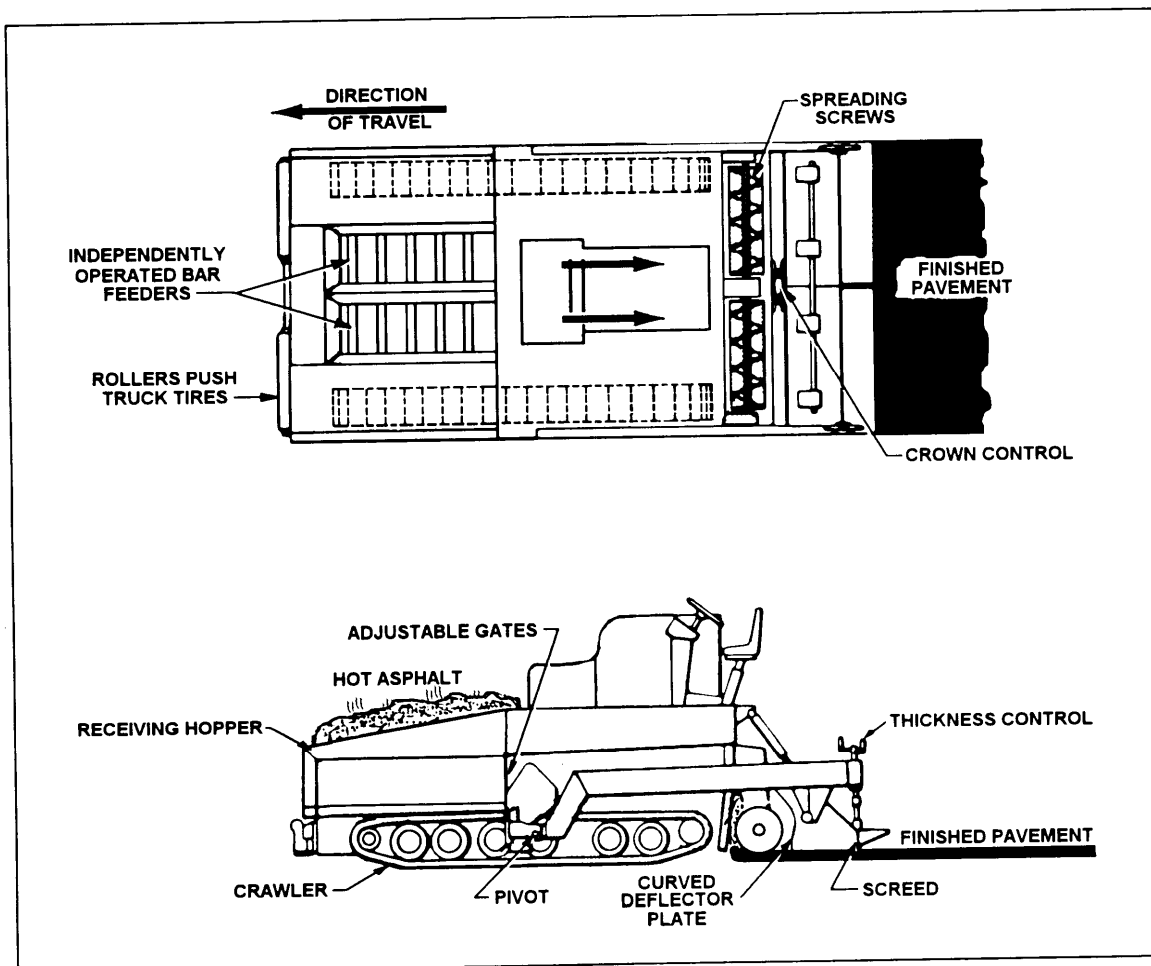

Figure 16-44.-Mat thickness and crown controls.

the mat and too little results in an open texture in the center. The trailing edge is what actually sets the crown. Crown adjustments may be made independently or simultaneously during the paving operation.

AUTOMATIC SCREED CONTROLS.— The screed controls must be adjusted by the screed operator as paving progresses. Automatic screed controls are designed to adjust automatically to place a uniform mat of the desired thickness, grade, and shape (fig. 16-45).

Types and Operating Principles.— Automatic screed controls can be used in several different ways, but all automatic screed control operations require a reference system for the automatic system to follow. This reference system can be the base on which the asphalt hot mix is being placed, the lane next to the material being placed, or a string line. When a string line is used as a reference, the automatic control will follow the height of the string line exactly, so the mat conforms to it; therefore, placement of the string line (or other reference system) must be precise.

Automatic screed controls can also follow traveling reference systems. A traveling reference system, such as a ski attached to a control arm, notes changes in base contours and adjusts the screed automatically to compensate.

A string line or traveling reference system allows the automatic control to adjust screed height as necessary to maintain proper longitudinal (lengthwise) grade of the pavement. Automatic screed controls use a system, attached to a beam, running between the two screed pull-arms to maintain proper transverse (widthwise) grade.

A pendulum in the slope control housing moves side to side with changes in the transverse grade of the roadway, triggering necessary adjustments in the slope control mechanism.

Automatic control systems have several advantages over manually controlled screed systems. Some of the advantages are as follows:

- Automatic controls compensate for changes in grade and slope more quickly than a screed operator could.
- Automatic controls help disassociate the screed from the erratic vertical movement of the tractor unit.
- Automatic controls adjust the screed tow points to enable the screed to follow a path parallel to the grade and slope of the reference system, which may be different from the path plane of the tractor unit.

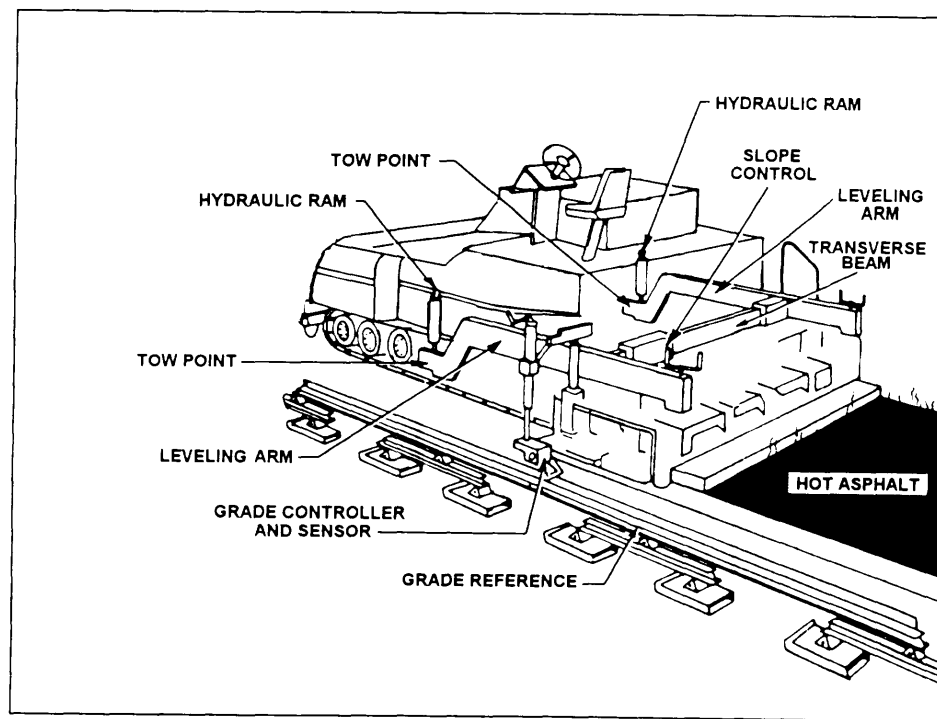

Figure 16-45.—Automatic screed reference system.

Selecting a Reference System.— Two types of reference systems, such as stationary or traveling, to use with an automatic screed control depend on the following factors:

- The condition of the surface on which the mat is to be placed.
- The degree of precision required in the grade and slope of the finished pavement.
- The thickness of the mat.
- The amount of material available for the project.

When the surface on which the mat is to be placed has a good longitudinal grade along its center line but has an unsatisfactory transverse grade, a traveling reference, run along the center line, can be used effectively to provide the desired mat thickness at the center line and the transverse slope control, used to establish the outside grade.

When the longitudinal grade is erratic, a string line should be placed to ensure a proper longitudinal grade. When the existing surface has a good profile

both longitudinally and transversely, automatic screed controls may be unnecessary. The self-leveling ability of the screed may be sufficient. When automatic controls are used, a traveling reference system would be adequate.

SCREED HEATERS.— The screed is equipped with heaters, used to heat the screed plate at the start of each new paving operation. The heaters are not used to heat the mix during the paving operation. If the screed is not initially heated, the mix will tear and the texture will look open and coarse, as it would if the mix were too cold. There are times when the paver operator allows the mix to heat the screed plate. This practice almost always results in a section of unsatisfactory pavement being laid while the screed is being heated.

SCREED ACCESSORIES.— Three types of commonly used screed accessories are screed extensions, cutoff shoes, and bevel end plates.

Screed Extensions.— Screed extensions (fig. 16-46) are attachments that widen the screed, allowing the paver to place a wider-than-normal mat. On some

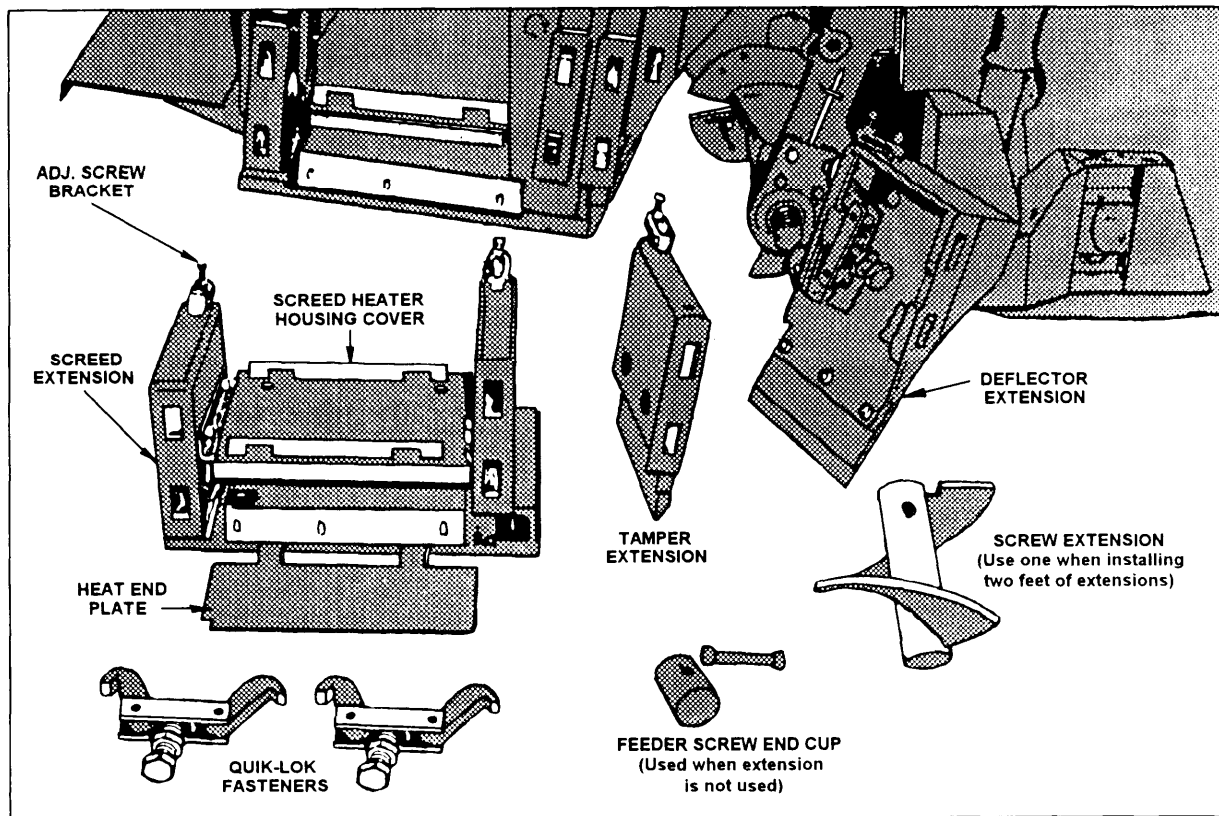

Figure 16-46.-Screed extension accessories.

models, screed extensions make it possible to pave widths up to 24 feet in a single pass.

Cutoff Shoes. — Cutoff shoes (fig. 16-47) have the opposite function of screed extensions. They are metal plates inserted into the screed to reduce the width of the mat being placed.

Bevel End Plates.— Bevel end plates (fig. 16-48) are used to bevel the edge of the mat. On some models, the shoes can be set at any one of three positions: vertical, 30 degrees, or 45 degrees.

Tons Per Hour

The equation, used to compute the amount of asphalt that can be laid with a paver per hour, is as follows:

$$\text{Tons per hour} = \frac{L \times W \times D \times 146}{2,000} \times 60$$

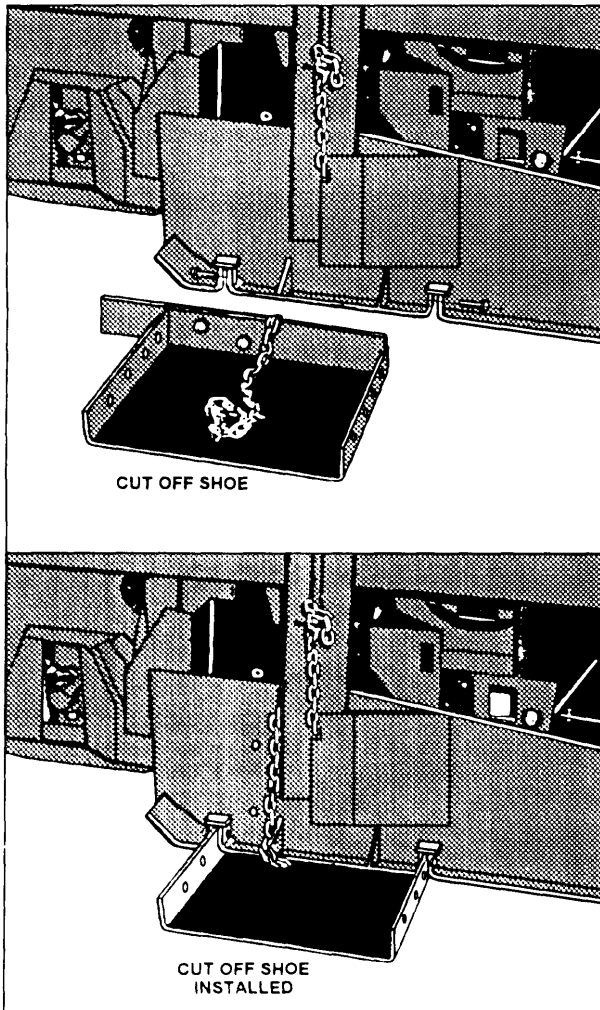

Figure 16-47.—Cutoff shoes.

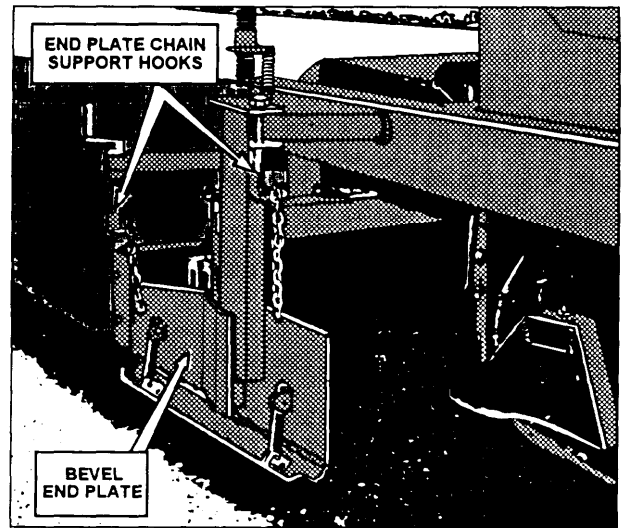

Figure 16-48.—Bevel end plates.

Where

L = Feet per minute. The NCF uses 11 feet per minute for planning purposes.

W = Width of the paver screed

D = Depth or thickness of compacted mat

146 = This number represents the approximate weight of 1 cubic foot of compacted hot-mix asphalt

60 = 60 minutes in 1 hour

2,000 = There are 2,000 pounds in 1 ton

Example: The required tonnage of hot-mix asphalt for a project is 800 tons. The screed of the paver is set at 10 feet, and the depth of asphalt is 2 inches. Estimate the amount of asphalt that can be laid per hour.

Solution:

$$\frac{11 \times 10 \times .167 \times 146 \times 60}{2,000} = \frac{160921.2}{2,000}$$

$$\frac{160921.2}{2,000} = 80.46 \text{ tons per hour}$$

By planning and estimating the amount of hot-mix asphalt that can be laid per hour, you are able to tell the asphalt plant exactly how much hot-mix asphalt is required to be delivered per hour or per day.

MAINTENANCE

As an Equipment Operator, it is your responsibility to coordinate the proper operation, care, use, adjusting,

cleaning, preservation, and lubrication of paving and support equipment. This includes daily inspections and adjustments, required for good operation. Malfunctions in equipment, which go beyond those operating adjustments performed by the EO, should be referred to the field mechanic for corrective action. This does not release you from working with the field mechanic unless you are directed otherwise.

PAVING SAFETY

Construction with bituminous materials involves several hazards. One of the most serious dangers is associated with the heating required to convert the solid or semisolid materials to a degree of fluidity which will permit their application or mixing. As a safety measure, make sure fire-extinguishing equipment (foam type) is present at all times.

When readying the distributor and/or asphalt kettle, be sure they are in a level position (before heating) and are located a safe distance from buildings and other flammable materials. Keep covers closed during the heating period to prevent the escape of flammable vapors; avoid exposure to fumes from hot bituminous material—stay on the windward side. Wear gloves and full body clothing to avoid prolonged skin contact or burns from hot bituminous material.

When heating bituminous materials for spraying purposes, you should check the temperature suggested in table 16-2 for the type and grade being used. Remember that most of the flush points are exceeded before the materials reach spraying or working temperature; therefore, additional caution must be exercised to prevent the exposure of rising fumes to an open flame. A dense yellow cloud or vapor, rising from the distributor or kettle, is an indication that the material is being overheated to the extent that a small spark is sufficient to ignite the vapors.

Always extinguish burners before spraying bituminous material. When spraying, stand at least 25 feet clear of the spray bar. On a bituminous distributor, spray bars have been known to blow open or rip with sudden pressure of heated materials. Remember that bituminous material must be heated to a high temperature, and any of this material coming in contact with the skin will leave a serious burn.

When handling asphalt that is being processed, you must wear proper protective apparel. Wear loose, heavy clothing that is in good condition. Clothing should be closed at the neck; sleeves should be rolled down over the tops of gloves. You should wear cuffless trousers

that extend well down over the top of safety shoes. Goggles should be worn to prevent eye burns from bubbling or splashing asphalt. In addition, you should wear a safety hard hat.

Frequently, bituminous operations are often planned for roads that must carry traffic while work is in progress. Slow or caution signs or other warning devices should be conspicuously placed at both 100 yards and 20 yards from each entrance of the project. Flagmen, dressed in safety vests or some other safety attire, should aid in traffic control.

Most airfields must remain operational during bituminous operations. The construction schedule, equipment routing, and maximum height of equipment should be discussed with the airfield safety officer. Liaison with air traffic control must be established if trucks and other equipment are to cross runways that are in use.

Machinery and mechanized equipment must be operated only by qualified and authorized personnel. It must not be operated in a manner that will endanger personnel or property. The safe operating speeds or loads must not be exceeded. Equipment, requiring an operator, must not be permitted to run unattended. Mounting or dismounting equipment while it is in motion, or riding on equipment by unauthorized personnel, is prohibited. All equipment, using fuel, must be shut down with the ignition off before and during refueling operations.

When paving equipment is being operated, frequent inspections of running mechanisms and attachments are the operator's responsibility. The operator is also responsible for inspecting such items as the power train, power plant, transmission, tracks, controls, guards, loading or unloading warning devices, and receiving hoppers.

When paving materials are being applied, crew members often become so occupied with their particular job that they are unaware of equipment operating near them. For this reason, at least one crew member should be designated as safety inspector to ensure that reasonable precautions are observed within the assigned working areas. In addition, the safety inspector should periodically hold short (approximately 5 to 15 minutes) safety meetings (called stand-up safety meetings), during which the inspector briefs the crew on the hazards and precautions relating to current work.

All hand tools used for paving purposes must be kept in good repair and used only for the purpose for which they were designed. When you are using hand

tools, such as rakes, shovels, lutes, and hand tampers, on asphalt paving jobs, these tools should be heated before use and cleaned immediately after use. It is common practice to clean these hand tools by burning off the bitumen, collected during paving operations. Crew members should exercise caution and be forewarned that flames are not always visible. One person should stand by with a fire extinguisher capable of controlling a petroleum fire.

In some areas, oiling roads and cleaning asphalt equipment could cause damage to the environment. This is especially important if there are streams or

waterways nearby that could be contaminated. Supervisors and crew members should be advised prior to the start of a job if there are any environmental considerations at the site. Dispose of contaminated rags and waste materials in an environmentally responsible manner.

All personnel should be instructed to report immediately all personal injuries and all property damage regardless of how minor. Reports should be prepared according to the instructions set forth in base or command publications.

APPENDIX I

GLOSSARY

AGGREGATE— Crushed rock or gravel, screened to sizes for use in road surfaces, concrete, or bituminous mixes.

ANGLING DOZER (Angledozer)—A bulldozer with a blade that can be pivoted on a vertical center pin so as to cast its load to either side.

APRON— The front gate of a scraper body.

ASPHALT— A dark brown to black cementitious material in which the predominating constituents are bitumens that occur in nature or are obtained in petroleum processing. Asphalt is a constituent in varying proportions of most crude petroleum.

ASPHALT CEMENT— A fluxed or unfluxed asphalt specially prepared as to quality and consistency for direct use in the manufacture of asphalt pavements.

ASPHALT CONCRETE— High-quality thoroughly controlled hot mixture of asphalt cement and well-graded, high-quality aggregate, thoroughly compacted into a uniform, dense mass.

ASPHALT LEVELING COURSE— A course (asphalt aggregate mixture) of variable thickness used to eliminate irregularities in the contour of an existing surface before a superimposed treatment or construction.

ASPHALT, MEDIUM-CURING (MC)— Cutback asphalt, composed of asphalt cement and a kerosene type of diluent of medium volatility.

ASPHALT, RAPID-CURING (RC)— Cutback asphalt, composed of asphalt cement and naphtha or gasoline type of diluent of high volatility.

ASPHALT, SLOW-CURING (SC)— Cutback asphalt, composed of asphalt cement and oils of low volatility.

AUGER— A rotating drill having a screw thread that carries cuttings away from the face.

AUXILIARY— A helper or standby engine or unit.

AXIS OF ROTATION— The vertical line around which the upper structure rotates.

AXLE, LIVE— A revolving horizontal shaft.

BACKFILL— (1) The material used in refilling a ditch or other excavation. (2) The process of such refilling.

BAIL BLOCK— Block attached to a dragline bucket, through which rope line is reeved. Also referred to as “PADLOCK.”

BAIL (BUCKET)— A yoke or spreader, hinged to the sides of a dragline bucket, to which is attached a connecting sheave or chain for hoisting and dragging operations.

BALL JOINT— A connection, consisting of a ball and socket, that will allow a limited hinge movement in any direction.

BANK— Specifically, a mass of soil rising above a digging or trucking level. Generally, any soil that is to be dug from its natural position.

BANK GRAVEL— Gravel found in natural deposits, usually more or less intermixed with fine material, such as sand or clay, and combinations thereof; gravelly clay, gravelly sand, clayey gravel, and sandy gravel indicate the varying proportions of the materials in the mixture.

BASE COURSE— The layer of material immediately beneath the surface or intermediate course. It may be composed of crushed stone, crushed slag, crushed or uncrushed gravel and sand, or combinations of these materials. It also may be bound with asphalt.

BANK YARDS— Yards of soil or rock measured in its original position (before digging).

BEDROCK— Solid rock, as distinguished from boulders.

BENCH— A working level or step in a cut that is made in several layers.

BINDER— (1) Fines which hold gravel together when it is dry. (2) A deposit check that makes a contract valid.

BITUMEN— A class of black or dark-colored (solid, semisolid, or viscous) cementitious substance, natural or manufactured, composed principally of

high molecular weight hydrocarbons, or which asphalts, tars, pitches, and asphaltites are typical.

BLASTING MAT— A heavy, flexible fabric of woven wire rope or chain, used to confine blasts.

BLEEDING OR FLUSHING— Is the upward movement of asphalt in an asphalt pavement, resulting in the formation of a film of asphalt on the surface. The most common cause is too much asphalt in one or more of the pavement courses, resulting from too rich a plant mix, an improperly constructed seal coat, too heavy a prime or tack coat, or solvent-carrying asphalt to the surface. Bleeding or flushing usually occurs in hot weather.

BLUE TOPS— Grade stakes with blue tops to indicate finish grade level, usually a 2-inch by 2-inch by 6-inch hub stake.

BM— Bench mark.

BODY— The load carrying part of a truck or scraper.

BOGIE AXLE— Two or more axles, mounted to a frame so as to distribute the load between the axles and permit vertical oscillation of the axles.

BOOM CHORD— A main corner member of a lattice type of boom.

BOOM, CRANE— A long, light boom, usually of lattice construction.

BOOM HOIST— Mechanism to control the elevation of the boom and to support it.

BOOM LACING— Structural truss members at angles to and supporting the boom chords of a lattice type of boom.

BOOM, LATTICE— A long, light boom fabricated of crisscrossed steel or aluminum angles or tubing.

BOOM LENGTH— Boom length is a straight line through the center line of the boom pivot into the center line of the boom point load hoist sheave pin, measured along the longitudinal axis of the boom.

BOWL— (1) The bucket or body of a carrying scraper. (2) Sometimes the moldboard or blade of a dozer.

BUCKET— A part of an excavator that digs, lifts, and carries dirt.

BULLDOZER— (1) A tractor equipped with a front pusher blade. (2) In a machine shop, a horizontal press.

CAPILLARY ATTRACTION— The tendency of water to move into fine spaces, as between soil particles, regardless of gravity.

CASING— A pipe lining for a drilled hole.

CAT— (1) A trademark designation for any machine made by the Caterpillar Tractor Company. (2) Widely used to indicate a crawler tractor of any make.

CAT HEAD— A capstan winch.

CATWALK— A pathway, usually of wood or metal, that gives access to parts of large machines.

CENTRIFUGAL FORCE— Outward force exerted by a body moving in a curved line. It is the force that tends to tip a car over in going around a curve.

C-FRAME— An angling dozer lift and push frame.

CHECK VALVE— Any device that will allow fluid or air to pass through it in only one direction.

CHOKER— A chain or cable so fastened that it tightens on its load as it is pulled.

CIRCLE REVERSE— The mechanism that changes the angle of a grader blade.

CLAM— A clamshell bucket.

CLAMSHELL— (1) A shovel bucket with two jaws that clamp together by their own weight when it is lifted by the closing line. (2) A crane equipped with a clamshell bucket.

CLAMSHELL BUCKET— Usually consists of two or more similar scoops hinged together and a head assembly connected to the outer corners by struts. When the head and hinge are pulled toward each other, the scoops are forced together to dig and hold material. Control is by a holding line reeved over a boom point sheave and attached to the head assembly to support the bucket in open position and usually by a closing line also reeved over a boom point sheave, ending in a force amplifying tackle or other means between the head assembly and scoop hinge to close the bucket.

CLAMSHELL BUCKET, HYDRAULIC— Usually consists of two or more scoops hinged to a head assembly housing the hydraulic cylinder or cylinders and the force amplifying linkage to open and close the scoops and to supply the digging force for the scoops. The bucket assembly is suspended from the boom by a rope. Because digging ability is largely dependent upon bucket weight, buckets are supplied in various weight classes which range from

light, for easily dug stockpiled materials, to heavy, for excavating hardpan material and the like.

CLAMSHELL EQUIPMENT— Machines with clamshell attachments are used to load material from stockpiles, gondola cars, barges, and the like, or from virgin soil generally out of small-area holes, deep trenches, or from below water. Orange peel buckets, grapples, and similar rope suspended attachments are included in this classification.

CLOSING LINE— The rope reeved from the hoist drum to control closing of a rope-operated clamshell bucket.

COFFERDAM— A set of temporary walls, designed to keep soil and/or water from entering an excavation.

COLLAR— A sliding ring, mounted on a shaft so that it does not revolve with it, used in clutches and transmissions.

COMPACTION— The act of compressing a given volume. Insufficient compaction of the asphalt pavement courses may result in channeling on the pavement surface. Compaction is usually accomplished by rolling.

CONVEYOR BELT— An endless belt of rubber-covered fabric that transports material on its upper surface.

CORRUGATIONS (WASHBOARDING) AND SHOVING— Are types of pavement distortion. Corrugation is a form of plastic movement typified by ripples across the asphalt pavement surface. Shoving is a form of plastic movement, resulting in localized bulging of the pavement surface. These distortions usually occur at points where traffic starts and stops, on hills where vehicles brake on the downgrade, on sharp curves, or where vehicles hit a bump and bounce up and down. They occur in asphalt layers that lack stability. Lack of stability may be caused by a mixture that is too rich in asphalt, has too high a proportion of fine aggregate, has coarse or fine aggregate that is too round or too smooth, or has asphalt cement that is too soft. It may also be due to excessive moisture, contamination due to oil spillage, or lack of aeration when placing mixes using liquid asphalt.

CRACKS— Breaks in the surface of an asphalt pavement.

CRACKS, ALLIGATOR— Interconnected cracks forming a series of small blocks resembling an alligator's skin or chicken wire, caused by excessive

deflection of the surface over unstable subgrade or lower courses of the pavement.

CRACKS, EDGE JOINT— Are the separation of the joints between the pavement and the shoulder, commonly caused by the alternate wetting and drying beneath the shoulder surface. Other causes are shoulder settlement, mix shrinkage, and trucks straddling the joint.

CRACKS, LANE JOINT— Longitudinal separation along the seam between two paving lanes caused by a weak seam between adjoining spreads in the courses of the pavement.

CRACKS, REFLECTION— Cracks in asphalt overlays that reflect the crack pattern in the pavement structure underneath. They are caused by vertical or horizontal movements in the pavement beneath the overlay, brought on by expansion and contraction with temperature or moisture changes.

CRACKS, SHRINKAGE— Are interconnected cracks forming a series of large blocks, usually with sharp corners or angles. Frequently they are caused by volume change in either the asphalt mix or in the base or subgrade.

CRACKS, SLIPPAGE— Are crescent-shaped cracks that are open in the direction of the thrust of wheels on the pavement surface. They result when there is a lack of good bond between the surface layer and the course beneath.

CRANE— A mobile machine, used for lifting and moving loads without the use of a bucket.

CRANE MATS— A device, used for supporting machines on soft ground, usually of timber construction.

CREEP— (1) Very slow travel of a machine or a part. (2) Unwanted turning of a shaft due to drag in a fluid coupling or other disconnect device.

CRUMBER— A blade that follows the wheel or ladder of a ditching machine to clean and shape the bottom.

CULVERT— A pipe or small bridge for drainage under a road or structure.

CURVE, VERTICAL— A change in gradient of the center line of a road or pipe.

CUTBACK ASPHALTS— Mixture of asphalt cement and a cutting agent. There are three main types.

DATUM— Any level surface taken as a plane of reference from which to measure elevations.

DEADHEADING— Traveling without a load, except when traveling from the dumping area to the loading point.

DENSITY— The ratio of the weight of a substance to its volume.

DIESELING— In a compressor, explosions of mixtures of air and lubricating oil in the compression chambers and/or other parts of the air system.

DOLLY— A unit consisting of a draw tongue, an axle with wheels, and a turntable platform to support a gooseneck trailer.

DOUBLE-CLUTCHING— Disengaging and engaging the clutch twice during a single-gear shift (change of gears) to synchronize gear speeds.

DOWNSTREAM FACE— The dry side of a dam.

DOZER— Abbreviation of bulldozer.

DRAFT— Resistance to movement of a towed load.

DRAGLINE— A crane with a dragline attachment, used to excavate material from below the grade on which the crane is sitting.

DRAWBAR— A fixed or hinged bar, extending to the rear of a tractor and used as a fastening for lines and towed machines or loads.

DRAWBAR HORSEPOWER— A tractor's flywheel horsepower minus friction and slippage losses in the drive mechanism and the tracks or tires.

DRAWBAR PULL— The pull that a tractor can exert on a load attached to the drawbar. Depends on power, weight, and traction.

DRILL COLLAR— Thick-walled drill pipe, used immediately above a rotary bit to provide extra weight.

DRILL, PERCUSSION— A drill that hammers and rotates a steel and bit. Sometimes limited to large blast hole drills of the percussion type.

DRILL PIPE— The sections of a rotary drilling string, connecting the kelly with the bit or collars.

DRIVE SPROCKET— A drive roller with teeth that engage matching recesses or pins (bushings) in the track assembly.

DROP HAMMER— A pile-driving hammer that is lifted by a cable and that obtains striking power by falling freely.

DRUM, SPUDDING— In a churn drill, the winch that controls the drilling line.

EJECTOR— A clean-out device, usually a sliding plate.

EMBANKMENT— A fill whose top is higher than the adjoining surface.

EROSION— Wear caused by moving water or wind.

FACE— (1) The more or less vertical surface of rock exposed by blasting or excavating or the cutting end of a drill hole. (2) An edge of rock used as a starting point in figuring drilling and blasting. (3) The width of a roll crusher.

FACTOR OF SAFETY— The ratio of the ultimate strength of the material to the allowable or working stress.

FAIRLEAD— A device which lines up cable so that it will wind smoothly onto a drum.

FEATHER— To blend the edge of new material into the old surface smoothly.

FIFTH WHEEL— The weight-bearing swivel connection between highway type of tractors and semitrailers.

FILL— An earth or broken rock structure or embankment. Soil or loose rock used to raise a grade. Soil that has no value except bulk.

FLOAT— In reference to a dozer blade, to rest by its own weight or to be held from digging by upward pressure of a load of dirt against its moldboard.

FOOT— In tamping rollers, one of a number of projections from a cylindrical drum.

FOOT-POUND— Unit of work equal to the force in pounds multiplied by the distance in feet through which it acts. When a 1-pound force is exerted through a 1-foot distance, 1 foot-pound of work is done.

FOUR BY FOUR (4 x 4)— A vehicle with four wheels or sets of wheels, all engine-driven.

FREE FALL— Lowering of the hook (with or without a load) without it being coupled to the power train with the lowering speed being controlled by a retarding device, such as a brake.

FRONT-END LOADER— A tractor loader with a bucket that operates entirely at the front end of the tractor.

FROST— Frozen soil.

FROST LINE— The greatest depth to which ground may be expected to freeze.

- GANTRY**— (1) An overhead structure that supports machines or operating parts. (2) An upward extension of the revolving frame of a crane that holds the boom line sheaves.
- GEAR**— A toothed wheel, cone, or bar.
- GOOSENECK**— An arched connection, usually between a tractor and a trailer.
- GRADE**— (1) Usually the elevation of a real or planned surface. (2) Also means surface slope.
- GRADER**— A machine with a centrally located blade that can be angled to cast to either side with an independent hoist control on each side.
- GRADE STAKE**— A stake indicating the amount of cut or fill required to bring the ground to a specified level.
- GRAVEL**— (1) Rock fragments from 2mm to 64 mm (.08 to 2.5 inches) in diameter. (2) A mixture of such gravel with sand, cobbles, boulders, and not over 15 percent fines.
- GRIEF STEM**— See “KELLY.”
- GRIZZLY**— (1) A coarse screen used to remove oversize pieces from earth or blasted rock. (Maybe spelled “grizzlie.”) (2) A gate or closure on a chute.
- GROUND PRESSURE**— The weight of a machine, divided by the area in square inches of the ground directly supporting it.
- GROUSER**— Projecting lug(s) attached to or integral with the machine track shoes to provide additional traction.
- GRUBBING**— Digging out roots.
- HAND LEVEL**— A sighting level that does not have a tripod, base, or telescope.
- HARDPAN**— (1) Hard, tight soil. (2) A hard layer that may form just below plow depth on cultivated land.
- HAUL DISTANCE**— (1) Is the distance measured along the center line or most direct practical route between the center of the mass of excavation and the center of mass of the fill as finally placed. (2) It is the distance the material is moved.
- HOLDING LINE**— The cable reeved from a hoist drum for holding a clamshell bucket or grapple suspended during dumping and lowering operations.
- HOOK, PINTLE**— A towing bracket, having a fixed lower part and a hinged upper one, which, when locked together, makes a round opening.
- HOPPER**— A storage bin or a funnel that is loaded from the top and discharges through a door or chute in the bottom.
- HORSEPOWER**— (1) A measurement of power that includes the factors of force and speed. (2) The force required to lift 33,000 pounds 1 foot in 1 minute.
- HORSEPOWER, DRAWBAR**— Horsepower available to move a tractor and its load after deducting losses in the power train.
- HOLDING LINE**— The hoist cable for a clamshell bucket.
- IDLER**— Large end roller of a track assembly at the opposite end from the drive sprocket; the roller is not power-driven.
- INJECTOR**— In a diesel engine, the unit that sprays fuel into the combustion chamber.
- JACK**— (1) A mechanical or hydraulic lifting device. (2) A hydraulic ram or cylinder.
- JACKKNIFE**— A tractor and trailer in such an angle that the tractor cannot move forward.
- JAW**— (1) In a clutch, one of a pair of toothed rings, the teeth of which face each other. (2) In a crusher, one of a pair of nearly flat faces separated by a wedge-shaped opening.
- JIB BOOM**— An extension piece, hinged to the upper end of a crane boom.
- KELLY**— A square or fluted pipe which is turned by a drill rotary table, while it is free to move up and down in the table. Also called a “GRIEF STEM.”
- LAGGINGS**— Removable and interchangeable drum spool shells for changing the hoist drum diameter to provide variation in rope speeds and line pulls.
- LAY**— The direction of twist in wires and strands in wire rope.
- LAY, REGULAR**— A wire rope construction in which the direction of twist of the wires in the strands is opposite to that of the strands in the rope.
- LEVEL**— To make level or to cause to conform to a specified grade.
- LIFT**— A layer or course of paving material, applied to a base or a previous layer.
- LIP**— The cutting edge of a bucket. Applied chiefly to edges including tooth sockets.
- LOAD BINDER**— A lever that pulls two grab hooks together and holds them by locking over the center.

- LOADER, FRONT-END**— A tractor loader that both digs and dumps in front.
- LOAM**— A soft easily worked soil, containing sand, silt, and clay.
- LOOSE YARDS**— Measurement of soil or rock after it has been loosened by digging or blasting.
- LOW BED**— A machinery trailer with a low deck.
- LUFFING**— Operation of changing the boom angle in the vertical plane. See “BOOM HOIST.”
- LUG DOWN**— To slow down an engine by increasing its load beyond its capacity.
- MASS DIAGRAM**— A plotting of cumulative cuts and fills, used for engineering computation of construction jobs.
- MINERAL DUST**— The portion of the fine aggregate passing the 0.075-mm (No. 200) sieve.
- MINERAL FILLER**— A finely divided mineral product, at least 70 percent or which will pass a 0.075-mm (No. 200) sieve. Pulverized limestone is the most commonly manufactured filler, although other stone dust, hydrated lime, portland cement, and certain natural deposits of finely divided mineral matter are also used.
- MISFIRE**— Failure of all or part of an explosive charge to go off.
- MOLDBOARD**— A curved surface of a plow, dozer blade, grader blade, or other dirt-moving implement that gives dirt moving over it a rotary, spiral, or twisting movement.
- MUCK**— Mud rich in humus.
- OIL**— Any fluid lubricant, but not water.
- OPEN-GRADED ASPHALT FRICTION COURSE**— A pavement surface course that consists of high-void, asphalt plant mix that permits rapid drainage of rainwater through the course and out the shoulder. The mixture is characterized by a large percentage of one-sized coarse aggregate. This course prevents tire hydroplaning and provides a skid-resistant pavement surface.
- OPTIMUM**— Best.
- OSCILLATION**— Independent movement through a limited range, usually on a hinge.
- OUTRIGGER**— An outward extension of a frame that is supported by a jack or block, used to increase stability.
- OVERBURDEN**— Soil or rock lying on top of a pay formation.
- PAN**— A carrying scraper.
- PAWL**— A tooth or set of teeth, designed to lock against a ratchet.
- PENETRATION**— The consistency of a bituminous material expressed as a distance in tenths of a millimeter (0.1mm) that a standard needle penetrates vertically a sample of the material under specified conditions of loading, time, and temperature.
- PERCENT OF GRADE**— Measurement of slope, expressed as the ratio of the change in vertical distance (rise) to the change in horizontal distance (run) multiplied by 100.
- PETCOCK**— A small drain valve.
- PILE CAP**— An adapter between the pile-driving unit and the upper end of the pile, used to center the pile under the pile-driving unit and to reduce damage to the upper end of the pile.
- PIONEERING**— The first working over of rough or overgrown areas.
- PIONEER ROAD**— A primitive, temporary road built along the route of a job to provide means for moving equipment and men.
- POND**— A small lake.
- PORT**— Left side of a ship or boat.
- POTHOLE**— A small steel-sided hole caused by traffic wear.
- POWER EXTRACTOR**— A unit hanging from the hoist line or block and attached to the upper end of the pile and containing within itself a member (ram) which is caused to reciprocate either by means of externally supplied air, steam, or hydraulic fluid under pressure, or by internal combustion within the unit. Upward pull from the hoisting machinery supplements the extraction forces.
- POWER PLANT**— The power plant (or plants) includes the prime power source (which may be an internal combustion engine or electric motor) and the power takeoff.
- POWER TAKEOFF**— A place in a transmission or engine to which a shaft can be so attached as to drive an outside mechanism. A power takeoff may be direct drive, friction clutch, fluid coupling,

hydrodynamic torque converter, hydrostatic, or an electric generator type.

POWER TRAIN— All moving parts connecting an engine with the point or points where work is accomplished.

PRIME MOVER— A tractor or other vehicle used to pull other machines.

PROPELLER SHAFT— Usually a main drive shaft fitted with universal joints.

PSI or psi— Pressure in pounds per square inch.

PUMP, DIAPHRAGM— A pump that moves water by the reciprocating motion of a diaphragm in a chamber having inlet and outlet check valves.

PUSHER— A tractor that pushes a scraper to help it pick up a load.

RAKE BLADE— A dozer blade or attachment made of spaced tines.

RAKE, ROCK— A heavy-duty rake blade.

RANGE POLE— A pole marked in alternate red and white bands, 1 foot high.

RED TOPS— Grade stakes with red tops to indicate finish subgrade level, usually a 2-inch by 2-inch by 6-inch hub stake.

REFUSAL— The depth beyond which a pile cannot be driven.

RIPRAP— Heavy stones placed at the edge of the water to protect the soil from waves or current.

RIPPER— A towed machine, equipped with teeth, used primarily for loosening hard soil and soft rock.

ROAD OIL— A heavy petroleum oil, usually one of the slow-curing (sc) grades.

ROCK— The hard, firm, and stable parts of earth's crust.

ROTARY TILLER— A machine that loosens and mixes soil and vegetation by means of a high-speed rotor equipped with tines.

RPM or rpm— Revolutions per minute.

RUBBLE DRAINS— French drains.

RULE OF THUMB— A statement or formula that is not exactly correct but is accurate enough for use in rough figuring.

SAND— A loose soil, composed of particles between 1/16 mm and 2 mm in diameter.

SCRAPER (Carrying scraper) (Pan)— A digging, hauling, and grading machine, having a cutting edge, a carrying bowl, a movable front wall (apron), and a dumping or ejecting mechanism.

SCREEN— (1) A mesh or bar surface, used for separating pieces or particles of different sizes. (2) A filter.

SEIZE— To bind wire rope with soft wire to prevent it from raveling when it is cut.

SEMITRAILER— A towed vehicle whose front rests on the towing unit.

SHEEPSFOOT— A tamping roller with feet expanded at their outer tips.

SHOE— (1) A ground plate, forming a link of a track or bolted to a track link. (2) A support for a bulldozer blade or other digging edge to prevent cutting down. (3) A clean-up device following the buckets of a ditching machine.

SIDECASTING— Piling spoil alongside the excavation from which it is taken.

SNATCH BLOCK— A pulley in a case that can be easily fastened to lines or objects by means of a hook, ring, or shackle.

SPILLWAY— An overflow channel for a pond or a terrace channel.

SPROCKET— A gear that meshes with a chain or a crawler track.

STOCKPILE— Material dug and piled for future use.

STONE— Rock.

SUPERCHARGER— A blower that increases the intake pressure of an engine.

SURGE BIN— A compartment for temporary storage.

SWELL (Growth)— Increase of bulk in soil or rock when it is dug or blasted.

SWING LOCK— A swing lock is a mechanical engagement device, not dependent on friction, to hold the upper structure in one or more fixed positions with respect to the undercarriage. When provided, it must be constructed to prevent unintentional engagement or disengagement.

SWING BRAKE (Dynamic)— A dynamic swing brake is a device to stop, hold, or retard the rotating motion of the upper structure with respect to the undercarriage.

SWITCHBACK— A hair-pin curve.

TAG LINE— A line from a crane boom to a clamshell bucket that holds the bucket from spinning out of position.

TAMP— Pound or press soil to compact it.

TERRACE— A ridge, a ridge and hollow, or a flat bench built along a ground contour.

TERRAIN— Ground surface.

TOE— The projection of the bottom of a face beyond the top.

TOOTH ADAPTER— Main part of bucket or dipper to which a removable tooth is fastened.

TOPOGRAPHIC MAP— A map, indicating surface elevation and slope.

TOPSOIL— The topmost layer of soil, usually refers to soil containing humus that is capable of supporting good plant growth.

TORQUE— The twisting force exerted by or on a shaft (without reference to the speed of the shaft).

TRACK— A crawler track.

TRACK CARRIER ROLLERS— Rolling elements in/on a track frame that support and guide the upper track shoes or chain.

TRACK SHOES— The members of the track assembly that distribute the load to the supporting surface.

TRACTION— The total amount of driving push of a vehicle on a given surface.

TRENCH— A ditch.

TRUNNION (Walking beam or bar)— (1) An oscillating bar that allows changes in angle between a unit fastened to its center and another attached to both ends. (2) A heavy horizontal hinge.

UNDERCARRIAGE— The undercarriage is an assembly that supports the upper structure of the crane. It consists of an undercarriage frame, a swing bearing, or hook and load rollers, travel mechanism, and steering mechanism. The undercarriage may be either a crawler or wheeled type.

VISCOSITY— The resistance of a fluid to flow. A liquid with a high viscosity rating will resist flow more readily than will a liquid with a low viscosity. The Society of Automotive Engineers (S.A.E.) has developed a series of viscosity numbers for indicating viscosities of lubricating oils.

VOIDS— Empty spaces in a compacted mix, surrounded by asphalt-coated particles.

VOLTS— The electromotive force that will cause a current of 1 ampere to flow through a resistance of 1 ohm.

WATERLOGGED— Saturated with water. If conditions are too wet, you will be unable to work construction equipment.

WATERSHED— Area that drains into or past a point.

WATER TABLE— The surface of underground, gravity-controlled water.

WHEEL AND AXLE ARRANGEMENT— The wheeled undercarriages.

WINCH— A drum that can be rotated so as to exert a strong pull while winding in a line.

WINDROW— A ridge of loose dirt.

WING WALL— A wall that guides a stream into a bridge opening or culvert barrel.

WORKING CYCLE— A complete set of operations. In an excavator, it usually includes loading, moving, dumping, and returning to the loading point.