



ENGINEERING-PDH.com  
ONLINE CONTINUING EDUCATION

# WORKING WITH STAINLESS STEELS - VOL 2 OF 2

<b>Main Category:</b>	Materials Engineering
<b>Sub Category:</b>	-
<b>Course #:</b>	MAT-1226
<b>Course Content:</b>	71 pgs
<b>PDH/CE Hours:</b>	8

**OFFICIAL COURSE/EXAM**  
(SEE INSTRUCTIONS ON NEXT PAGE)

[WWW.ENGINEERING-PDH.COM](http://WWW.ENGINEERING-PDH.COM)

TOLL FREE (US & CA): 1-833-ENGR-PDH (1-833-364-7734)

[SUPPORT@ENGINEERING-PDH.COM](mailto:SUPPORT@ENGINEERING-PDH.COM)

# MAT-126 EXAM PREVIEW

**- TAKE EXAM! -**

## Instructions:

- At your convenience and own pace, review the course material below. When ready, click "Take Exam!" above to complete the live graded exam. (Note it may take a few seconds for the link to pull up the exam.) You will be able to re-take the exam as many times as needed to pass.
- Upon a satisfactory completion of the course exam, which is a score of 70% or better, you will be provided with your course completion certificate. Be sure to download and print your certificates to keep for your records.

## Exam Preview:

1. Using Table 3.1.1 - Weld characteristics and recommended precautions for different types of stainless steel, which of the following types of stainless steel matches the characteristics: Excellent toughness and good ductility in the temperature range  $-40^{\circ}\text{C}$  to  $+275^{\circ}\text{C}$ ?
  - a. Martensitic
  - b. Semi-ferritic
  - c. Austenitic
  - d. Austenitic-ferritic Duplex
2. According to the reference material, upset welding, or resistance butt welding is used essentially for long products (rods, bars, tubes, shaped sections, etc.).
  - a. True
  - b. False
3. According to the reference material, \_\_\_\_\_ is probably the most suitable heating process for the series brazing of parts with complex geometries.
  - a. Oxyacetylene torch heating
  - b. Induction heating
  - c. Furnace heating
  - d. Convection heating
4. According to the reference material, hardness is a measure of the energy necessary for fracture and implicitly involves the tendencies for either brittle cleavage or ductile tearing, together with the transition temperature at which the fracture mode changes from one to the other.
  - a. True
  - b. False

5. According to the reference material, stainless steel screws and bolts are produced in all the principal grades. The \_\_\_% Cr martensitic alloys are used when high strength is required.
  - a. 8
  - b. 10
  - c. 13
  - d. 17
6. Which of the following mechanical joining techniques discussed in the reference material matches the description: mechanical sheet joining technique in which the edges of one or both of the sheets concerned are bent through an angle of 180°?
  - a. Tube expansion
  - b. Riveting
  - c. Clinching
  - d. Lockseaming
7. Peening induces a heavily cold worked surface layer, whose thickness can attain 0.3 mm. The associated compressive stresses can have a beneficial influence on fatigue strength, and peening thus provides a means of increasing the service life of finished components.
  - a. True
  - b. False
8. Using Table 4.1.2 - Principal surface finishes for stainless steel flat products, which of the roughness values corresponds to a product with a grain size of 180?
  - a. <math>< 5.5 \mu\text{m}</math>
  - b. <math>< 1 \mu\text{m}</math>
  - c. 0.3-0.6  $\mu\text{m}$
  - d. 0.1-0.3  $\mu\text{m}$
9. Using Table 5.2.1 - Typical mechanical properties of the different stainless steels in various conditions, which of the following materials experienced the greatest % El?
  - a. Tempered Martensitic
  - b. Annealed Ferritic
  - c. As-quenched Martensitic
  - d. Solution annealed and rapidly cooled Austenitic
10. According to the reference material, Gas Metal Arc Welding (GMAW) is still extensively used and is particularly suited to the welding of thin stainless steel sheets.
  - a. True
  - b. False

# WORKING WITH STAINLESS STEELS VOL 2 OF 2

## 3. Joining operations

### 3.1 Welding

The microstructure of stainless steel welds in the as-welded condition, i.e. without any further heat treatment, is mainly determined by the concentrations of different alloying elements. The latter can be divided into two groups of opposite influence:

- Austenite stabilizers, which act like nickel, including carbon, manganese, cobalt, copper, etc.
- Ferrite stabilizers, which act like chromium, such as molybdenum, silicon, niobium, titanium, aluminum, etc.

The combined effects of the various elements can be evaluated in terms of a chromium equivalent and a nickel equivalent, and are represented graphically in diagrams with these two parameters as the orthogonal axes, in which the different as-welded microstructures are represented as “phase fields”. The best known diagram is that due to Schaeffler (1949), but improved versions also exist, such as the De Long (1973) and Welding Research Council – WRC (1992) diagrams. It is found that:

- Fully austenitic weld structures, generally associated with high nickel contents, are sensitive to the solidification cracking or “hot cracking” phenomenon, which occurs during cooling, at temperatures above about 1250 °C.
- Completely ferritic weld structures are strongly prone to grain coarsening at high temperatures, above about 1150 °C, which can cause loss of ductility and toughness, leading to low temperature brittleness.
- Entirely martensitic structures are susceptible to cold or hydrogen-assisted cracking, which originates during cooling at temperatures below 400 °C and is generally of a delayed nature, occurring from a few hours to several days after the welding operation.

The microstructural modifications that occur in the different types of stainless steel during welding, together with the recommended precautions, are given in Table 3.1.1.

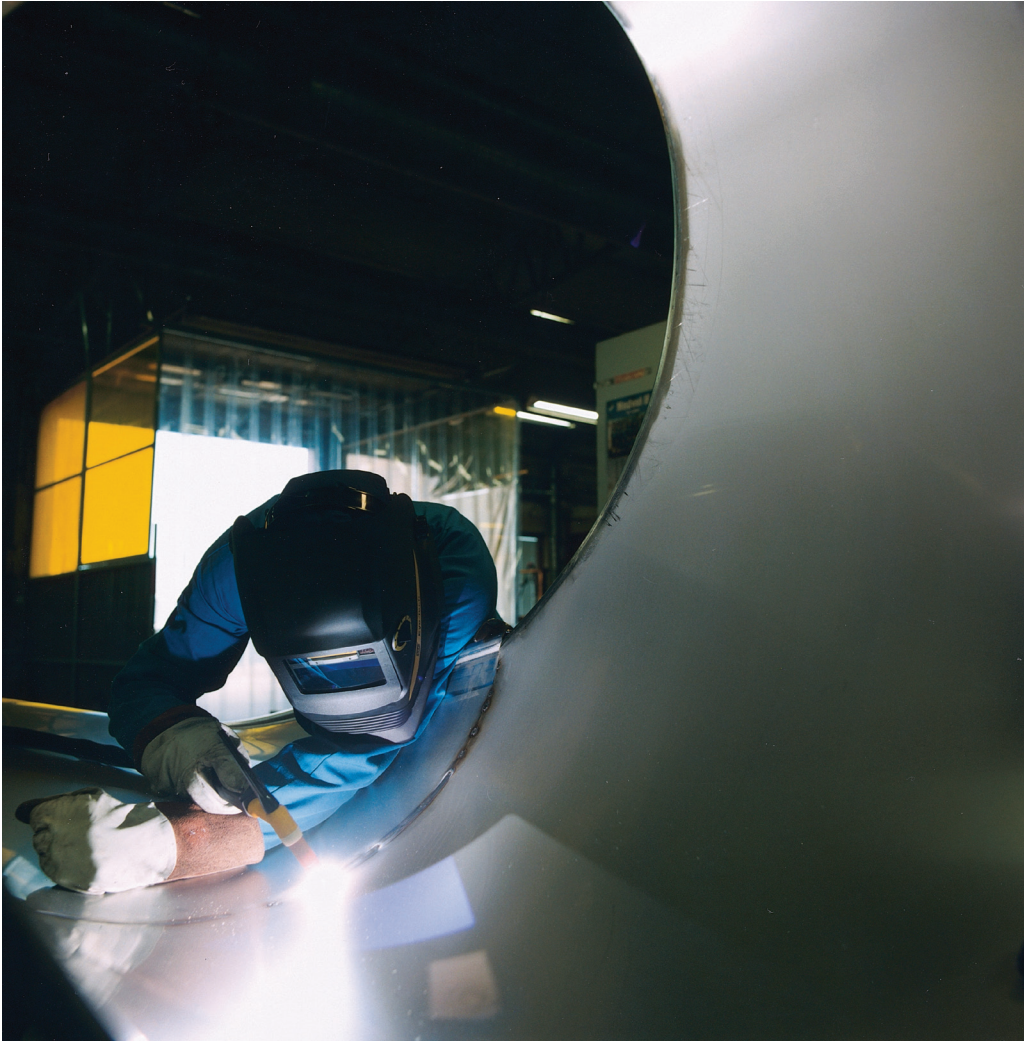

*Photo 9: Manual Gas Tungsten Arc Welding*

Type of stainless steel	Principal characteristics of the as-welded joint and recommended precautions
Martensitic 10,5–13% Cr 0.2–0.5% C	<ul style="list-style-type: none"> <li>• Sensitive to cold cracking, depending on the carbon and hydrogen contents and residual stress levels, below about 400 °C, whence the following recommendations: <ul style="list-style-type: none"> <li>– Preheating to 200-300 °C is generally necessary;</li> <li>– Use of low hydrogen welding products;</li> <li>– Post heating to about 300 °C.</li> </ul> </li> <li>• High tensile strength and hardness.</li> <li>• Good toughness, particularly for low carbon grades.</li> </ul>
Semi-ferritic 17% Cr 0.04% C	<ul style="list-style-type: none"> <li>• Sensitive to embrittlement by grain coarsening above 1150 °C (preheating to be proscribed).</li> <li>• Poor toughness and ductility.</li> <li>• Sensitive to intergranular corrosion, particularly in the heat affected zone, (HAZ).</li> <li>• Post-weld heat treatment at about 800 °C restores the mechanical properties and intergranular corrosion resistance.</li> </ul>
Ferritic 17–30% Cr 0.02% C Stabilized with: Ti, Nb	<ul style="list-style-type: none"> <li>• Sensitive to embrittlement by grain coarsening above 1150 °C (preheating to be proscribed).</li> <li>• Sensitive to the so-called « 475°C embrittlement » (temperature range : 350-550°C) which can be reversed by annealing</li> <li>• Satisfactory ductility and improved toughness compared to semi-ferritic grades.</li> <li>• Generally insensitive to intergranular corrosion.</li> </ul>
Austenitic 18% Cr–8% Ni 0.05% C	<ul style="list-style-type: none"> <li>– <i>Fully austenitic structures:</i> <ul style="list-style-type: none"> <li>• Sensitive to hot cracking during solidification.</li> <li>• Good resistance to intergranular corrosion for stabilized and low carbon grades.</li> <li>• Excellent toughness and ductility.</li> </ul> </li> <li>– <i>Structures containing a few percent of ferrite:</i> <ul style="list-style-type: none"> <li>• Insensitive to hot cracking.</li> <li>• Good resistance to intergranular corrosion for stabilized and low carbon grades.</li> <li>• Embrittlement by decomposition of the ferrite to form sigma phase for long exposures between 550 °C and 900 °C, such as can occur in heavy gage products. The relative effects of temperature and time are illustrated by the fact that 1000 hours at 650 °C is roughly equivalent to 10 hours at 750 °C.</li> <li>• Excellent toughness and ductility.</li> </ul> </li> </ul>
Austenitic-ferritic Duplex 22% Cr–5% Ni 3% Mo–0.02% C	<ul style="list-style-type: none"> <li>– <i>Two-phase austenite + ferrite structures:</i> <ul style="list-style-type: none"> <li>• Insensitive to hot cracking.</li> <li>• Excellent toughness and good ductility in the temperature range -40 °C to +275 °C.</li> <li>• Sensitive to embrittlement by sigma phase when exposed between 500 °C and 900 °C.</li> </ul> </li> </ul>

Table 3.1.1 - Weld characteristics and recommended precautions for different types of stainless steel

### Welding processes

There are a large number of welding processes that can be applied to stainless steels, but only a few of them are really appropriate for these materials, and are summarized in Table 3.1.2.

Electric arc processes	Resistance and induction processes	Radiation energy processes
<ul style="list-style-type: none"> <li>• With a refractory metal electrode:                             <ul style="list-style-type: none"> <li>– GTAW or TIG or WIG</li> <li>– PAW (plasma)</li> </ul> </li> <li>• With a fusible electrode:                             <ul style="list-style-type: none"> <li>– GMAW or MIG</li> <li>– SMAW (covered electrode)</li> <li>– SAW (Submerged metal arc)</li> <li>– FCAW (flux-cored arc)</li> </ul> </li> </ul>	<ul style="list-style-type: none"> <li>• Pure resistance heating:                             <ul style="list-style-type: none"> <li>– spot welding</li> <li>– seam welding</li> <li>– projection welding</li> </ul> </li> <li>• Flash butt welding</li> <li>• High frequency HF or medium frequency MF induction welding (longitudinal welding of tubes)</li> </ul>	<ul style="list-style-type: none"> <li>• Laser beam welding</li> <li>• Electron beam welding</li> </ul>

Table 3.1.2 - The principal welding processes used for joining stainless steels

### Arc welding

#### Gas Tungsten Arc Welding (GTAW)

The GTAW (Gas Tungsten Arc Welding) process, also known as the TIG (Tungsten Inert Gas) or WIG (Wolfram Inert Gas) process, is illustrated in figure 3.1.1. The energy necessary to melt the metal is supplied by an electric arc struck and maintained between a tungsten or tungsten alloy electrode and the workpiece, under an inert or slightly

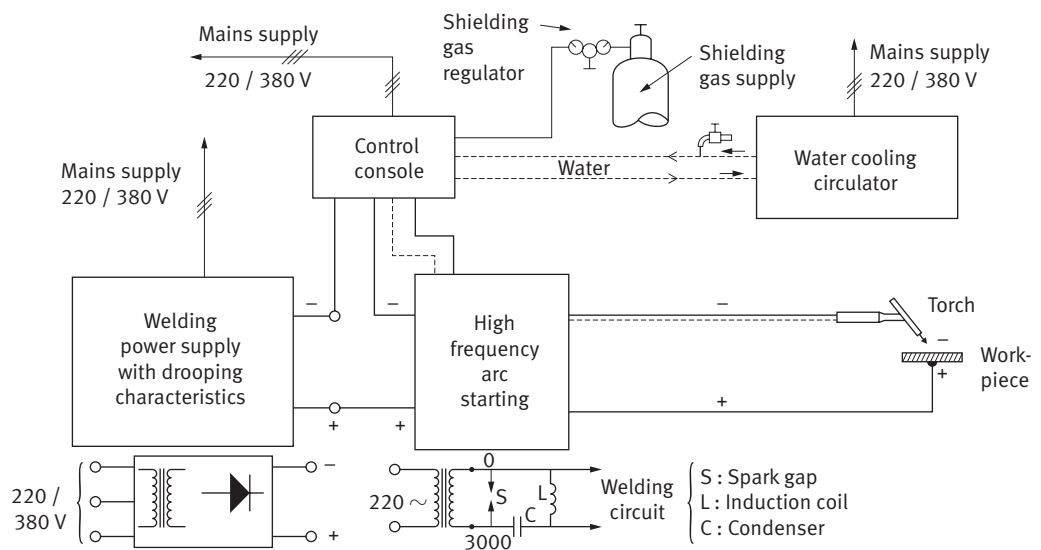

Fig. 3.1.1 - Principle of a GTAW or TIG manual welding apparatus



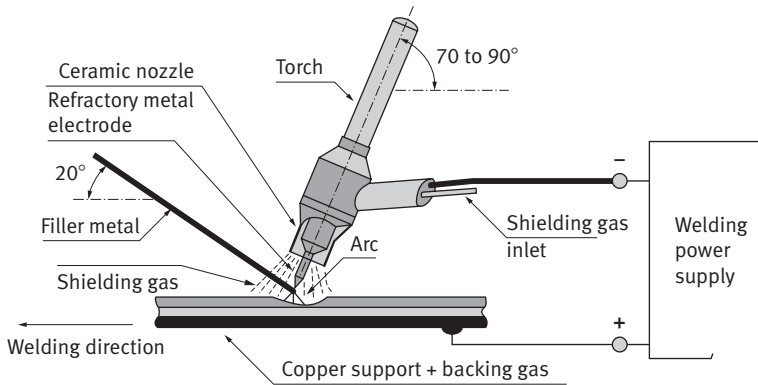

Fig. 3.1.2 - Example of manual welding using the GTAW (TIG) process

reducing atmosphere. Stainless steels are always welded in the DCEN (direct current electrode negative) or straight polarity DC mode, the negative pole of the generator being connected to the electrode. In these conditions, it is the workpiece that is struck by the electrons, enhancing penetration, while the electrode, which is generally made from thoriated tungsten (2% ThO<sub>2</sub>), undergoes very little wear. Welding is performed either manually or automatically. If a filler metal is employed, it is in the form of either bare rods (fig. 3.1.2) or coiled wire for automatic welding (fig. 3.1.3). The inert gas flow which protects the arc zone from the ambient air enables a very stable arc to be maintained.

The advantages of this process for welding stainless steels can be summarized as follows:

- a concentrated heat source, leading to a narrow fusion zone;
- a very stable arc and calm melt pool of small size;
- good quality, sound and pore-free welds;
- very low electrode wear;
- rapid apprenticeship.

The active component of the torch is its refractory electrode, generally made from

thoriated tungsten (1–3% ThO<sub>2</sub>), which facilitates initiation of the arc and decreases the risk of contamination. In the recommended DCEN mode, the electrode diameter must be chosen as a function of the welding current as indicated in Table 3.1.3.

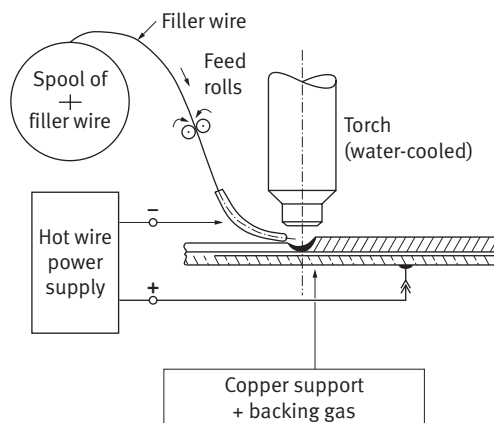

Fig. 3.1.3 - Example of automatic welding using the GTAW process. The filler metal can be used either cold or hot. In the latter case, it is resistance heated via an auxiliary current source

DCEN welding current (A)	Electrode diameter (mm)
25 – 70	1.0
60 – 150	1.6
100 – 200	2.0
200 – 350	3.0
350 – 500	4.0
500 – 800	5.0

Table 3.1.3 - Refractory electrode diameter as a function of welding current



The shielding gases are defined by the EN 439 standard. Pure argon is generally used in manual welding, although argon-helium or argon-hydrogen mixtures can be employed in certain difficult cases. However, argon-oxygen mixtures are to be proscribed, since they lead to rapid deterioration of the refractory electrode. Argon-helium mixtures are used when a compromise is sought between the arc stability and facility of initiation characteristic of argon and the good penetration, high welding speeds and sound structures promoted by helium. Mixtures of this type can be used for austenitic, ferritic and martensitic stainless steels. Argon-hydrogen mixtures (R1 or R2) are widely used for welding austenitic stainless steels, for both automatic and manual welding. The 95% Ar–5% H<sub>2</sub> mixture is often employed for automatic welding, since it improves penetration, decreases the width of the weld seam, and significantly increases the welding speed (by up to 50% compared to pure argon). With argon-hydrogen mixtures, the risk of undercut formation is less than for argon-helium mixtures. However, argon-hydrogen mixtures must not be used for welding ferritic, martensitic or duplex stainless steels, due to the risk of hydrogen embrittlement in the weld joint. For the welding of duplex stainless steels without filler metal, argon-nitrogen mixtures are often used in order to maintain a correct balance of austenite and ferrite in the weld, since nitrogen is a powerful austenite stabilizer.

For the backing gas, which protects the rear of the workpiece, argon is most commonly employed, although nitrogen is sometimes used for duplex grades, or for austenitic alloys where it is sought to reduce the amount of ferrite at the weld root. However,

like hydrogen, nitrogen is to be proscribed for ferritic and martensitic stainless steels.

In welding applications, the term “stainless steels” is often implicitly reduced to austenitic stainless steels. It must not be forgotten that the ferritic, duplex, and even martensitic grades, can also be welded, albeit with significantly different operating procedures. In particular, welds of remarkable quality can be obtained with the titanium and/or niobium stabilized ferritic stainless steels, provided that certain elementary precautions are taken concerning hydrogen and nitrogen.

When a filler metal is necessary, it is in the form of either a bare rod for manual welding, or a coiled wire for automatic processes.

The TIG process can be readily automated due to the very low electrode wear and the highly stable arc. The main problem in automation is to maintain the arc length constant as it is displaced longitudinally along the joint. In all cases, it is essential to carefully prepare the edges to be joined and to ensure a regular feed of filler wire.

For sheet thicknesses between 1.5 and 15 mm, it is frequent in manual welding to operate in the vertical up butt mode (fig. 3.1.4). In this case, the molten pool is well protected from the external atmosphere, since the two sides of the joint are in contact with the shielding gas.

It is also common practice to use the TIG process for spot welding (fig. 3.1.5). The weld spot is obtained by striking the arc at the corresponding position and then maintaining it for the required length of time. The torch is equipped with a special nozzle which allows the gas to escape. The top sheet must be sufficiently thin to be

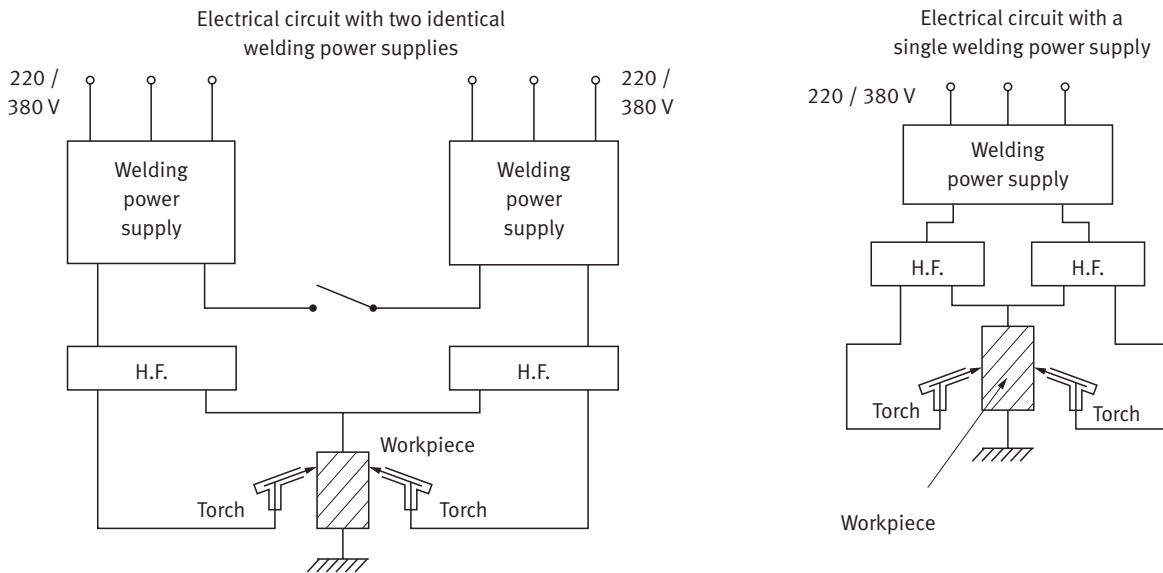

Fig. 3.1.4 - Principle of simultaneous two-operator TIG welding – Two operators weld in one pool on both sides at the same time

readily penetrated, generally between 0.5 and 1.5 mm. The shielding gases that can be used in this case are pure argon, and argon-helium mixtures when deeper penetration is required. Argon-hydrogen mixtures can also be employed, but must be strictly reserved for austenitic grades.

Activating flux TIG (A-TIG) or flux-assisted GTA welding is a new method in which Gas Tungsten Arc Welding (GTAW) is conducted by covering a thin layer of an activating flux on the weld preparation before starting the welding operation.

The aim of this method is to increase the performance and productivity of the GTA process. The main improvement lies in that the penetration can be increased up to three times. This technology was first established in the 1960s by the E.O. Paton Electric Welding Institute of Ukraine.

The action of activating flux is based on its influence on the surface gradient  $d\gamma$ , which takes place in the weld pool. Normally, surface tension gradients decrease with increasing of

Fig. 3.1.5 - Principle of spot welding using the TIG process

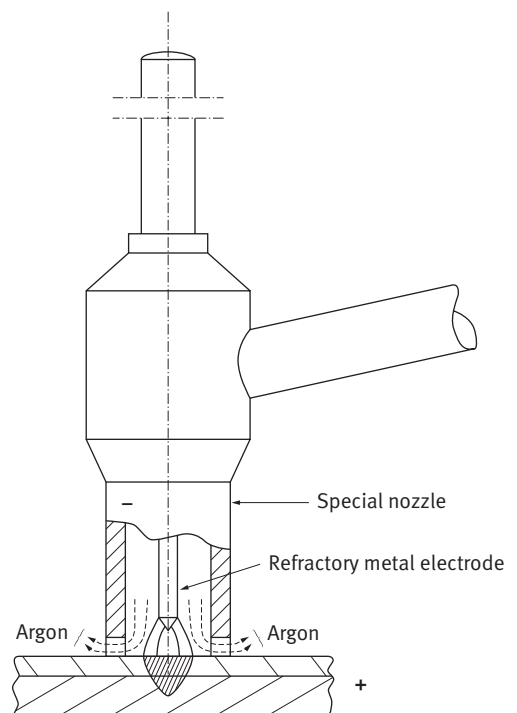

temperature ( $T$ ) in many alloys, i.e.  $d\gamma/dT < 0$ , and molten metal flows from the region with low surface tension to that with high surface tension ( $\gamma_2 > \gamma_1$ ).

The temperature  $T_1$  being higher at the center of the weld pool, the surface tension  $\gamma_1$  at the center is lower than  $\gamma_2$  in the outer zone. Therefore, molten metal flows as shown in figure 3.1.6 given a relatively wide shallow weld.

However, a surface-active element such as sulphur (S) can change the direction of

the molten metal in weld pool. With a sufficient content in sulphur (of the order of 0.007%),  $d\gamma/dT > 0$  and the molten metal flows as shown in figure 3.1.7, giving a relatively deep and narrow weld.

If there is a surface tension gradient in the weld pool (Marangoni effect) as it is shown in figure 10.7, the convection currents are directed towards the interior of the weld pool promoting a good penetration. If not, penetration can be improved by a factor of up to three using activating flux.

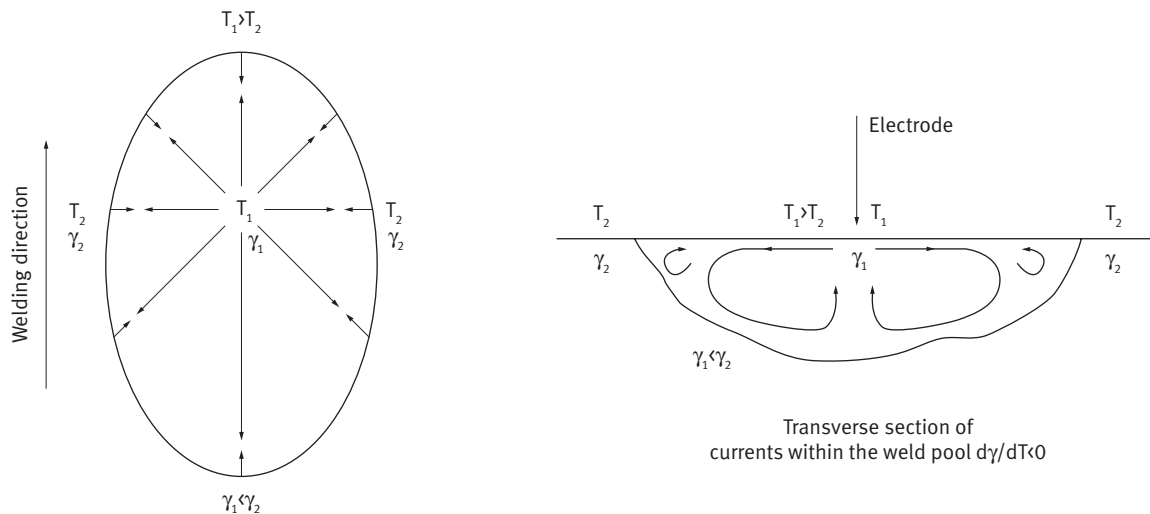

Fig. 3.1.6 – Fluid flow on and below the weld pool surface – negative surface tension temperature coefficient

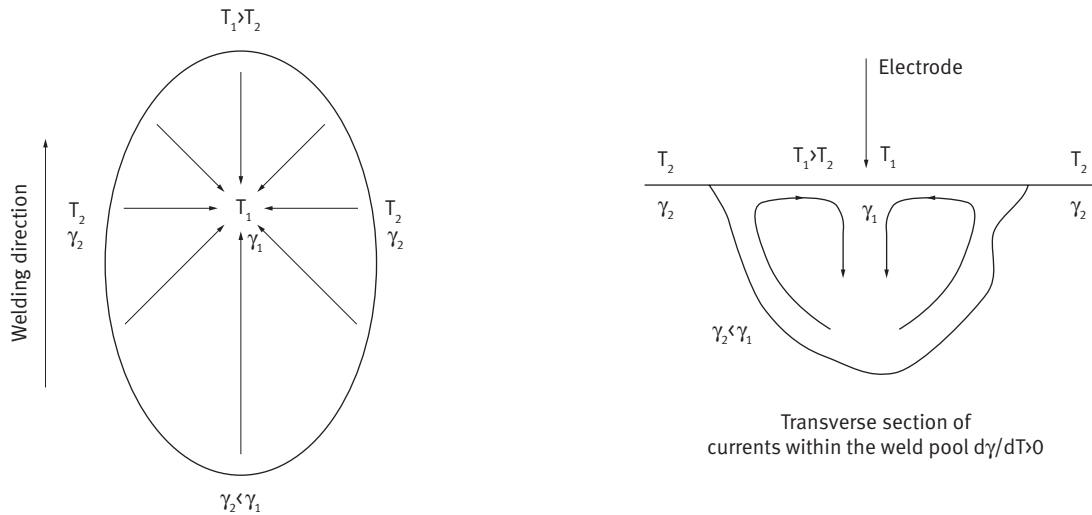
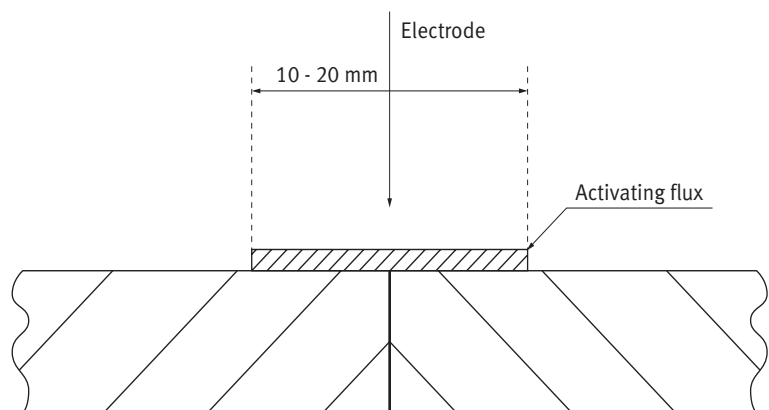

Fig. 3.1.7 – Fluid flow on and below the weld pool surface – positive surface tension temperature coefficient

Activating fluxes are normally easy to handle. They can be used for autogenous GTA welding on thin materials for the purpose of minimizing the effects of heat-to-heat variations and mainly on thick materials up to the order of 5 mm – using a square butt penetration – to achieve full penetration in a single pass. The activating flux is applied – figure 3.1.8 – to the weld preparation as a slurry using a brush, dries in very short time, and is ready to be welded using conventional GTA

welding. For multiple pass welding it is recommended to remove previously fused flux from the weld using a stainless steel brush.

Fig. 3.1.8 – Joint cross section



### Gas Metal Arc Welding (GMAW)

The GMAW (Gas Metal Arc Welding) process, also known as the MIG (Metal Inert Gas) process, is illustrated in figure 3.1.9. Contrary to the GTAW process, the electrode

is consumable, an arc being struck between the fusible filler wire and the workpiece under a shielding gas. The essential characteristics of this process are:

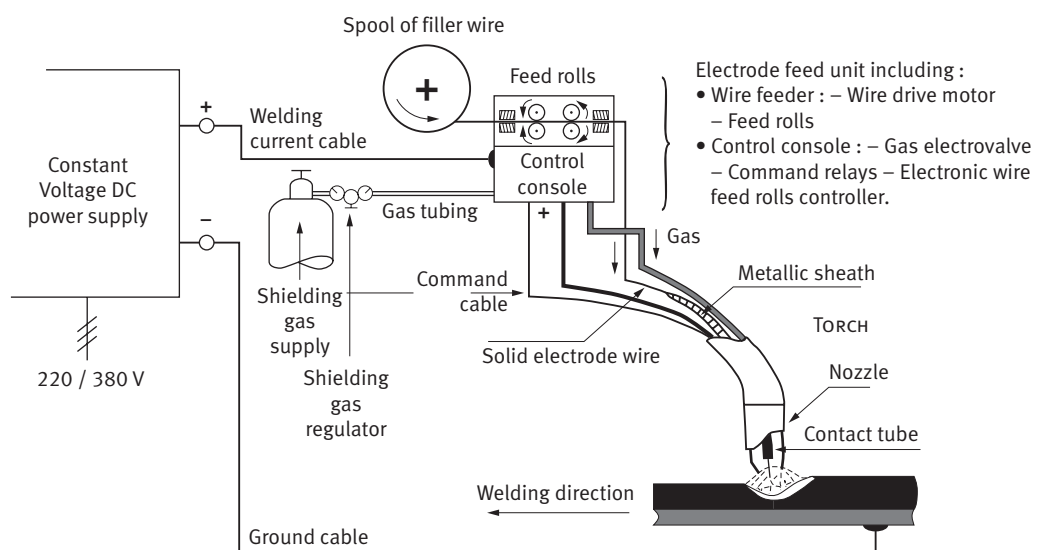

- the use of very high current densities in the electrode wire ( $> 90 \text{ A/mm}^2$ ), about 10 times higher than in the covered electrode (SMAW) process;
- rapid melting of the electrode wire (about 8 m/min) due to the high temperature of the arc, making it necessary to use an automatic wire feed system, supplied by 12 kg spools;
- stainless steels are always welded in the DCEP (direct current electrode positive) or reverse polarity DC mode, the positive pole of the generator being connected to the electrode;
- the welding torch is generally held manually (so-called “semi-automatic” process),

but for high welding powers it is fixed to a carriage (“automatic” process).

The mechanism of metal transfer in the arc is an important process parameter, three principal modes being distinguished (fig. 3.1.10):

- The short-circuiting or dip transfer mode, in which the metal melts to form large droplets, whose diameter is often greater than that of the electrode wire. As the droplet forms at the end of the electrode, it makes contact with the melt pool and creates a short circuit, with a sudden increase in current. The surface tension causes a pinching effect which separates the droplet from the electrode. The frequency of this phenomenon is of the

order of 20 to 100 Hz, corresponding to cycle times between 0.01 and 0.05 seconds.

- The globular or gravity transfer mode. As in the previous case, melting occurs in the form of large droplets, which break away when their mass is sufficient to overcome surface tension forces, and due to the greater arc length, fall freely before coming into contact with the melt pool.
- The spray transfer mode involves current densities above a certain transition level, of the order of  $200 \text{ A/mm}^2$ . The electrode melts to give a stream of fine droplets. As the current density increases further, the end of the electrode becomes conical and the stream of even finer droplets is released axially.

The shielding gases are defined by the EN 439 standard. They must be either neutral, slightly reducing, or very slightly oxidizing. The principal mixtures employed are as follows:

#### Argon-oxygen mixtures (M13)

Very small concentrations of oxygen are sufficient to significantly reduce the surface tension of the liquid metal and increase the stability of the arc. The weld bead then shows better wetting behaviour and the risk of undercut formation diminishes. However, the effect of oxygen is most marked in the spray transfer mode. In practice, the oxygen content is limited to 2% whatever the grade of stainless steel.

#### Argon-CO<sub>2</sub> mixtures (M12)

The effects of CO<sub>2</sub> on transfer are similar to those of oxygen, but since the corresponding

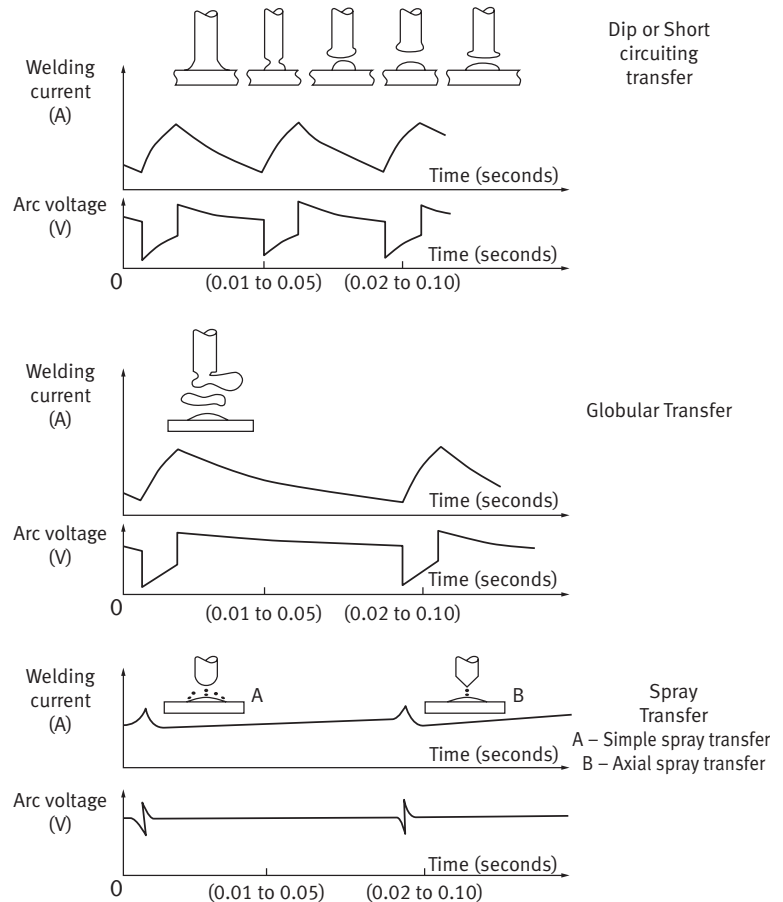

Fig. 3.1.10 - Metal transfer modes in MIG welding

oxygen potential is much lower, oxidation of the weld bead is significantly reduced. In practice, the CO<sub>2</sub> content is limited to 3%, which is the maximum permissible value for ferritic stainless steels.

#### Argon-CO<sub>2</sub>-H<sub>2</sub> mixtures (M11)

These mixtures are widely used, the typical composition being 95–96% Ar, 3% CO<sub>2</sub>, 1–2% H<sub>2</sub>. They give excellent arc stability in

the short-circuit transfer mode and the CO<sub>2</sub> does not cause appreciable carbon pick-up. However, the hydrogen content is sufficiently high for these mixtures not to be recommended for ferritic stainless steels when no post-weld heat treatment is to be performed.

*Argon-helium-oxygen and argon-helium-CO<sub>2</sub> mixtures*

These mixtures can be considered as a logical extension of the argon-oxygen and argon-CO<sub>2</sub> mixtures. They are observed to enhance the fluidity of the melt pool, to improve the bead profile and to produce a more sound, compact weld. When the oxygen and CO<sub>2</sub> levels remain less than 2 and 3% respectively, they can be used for welding ferritic stainless steels.

*Argon-oxygen-nitrogen and argon-CO<sub>2</sub>-nitrogen mixtures*

For welding nitrogen-containing austenitic stainless steels and duplex grades, nitrogen can be added to the shielding gas to minimize losses from the molten metal. In the case of duplex alloys, nitrogen plays an important role in obtaining the correct balance between austenite and ferrite in the weld structure.

The welding parameters recommended for the MIG welding of austenitic stainless steels with solid electrode wire and argon-oxygen or argon-CO<sub>2</sub> shielding gas are indicated in Table 3.1.4.

As for TIG welding, there is a MIG spot welding process, using a torch equipped with a special nozzle (fig. 3.1.11) and a control unit with a timing device, enabling adjustment of the duration of the arc maintenance period (from 0.5 to 5 seconds).

Fig. 3.1.11 - Spot welding using the GMAW process

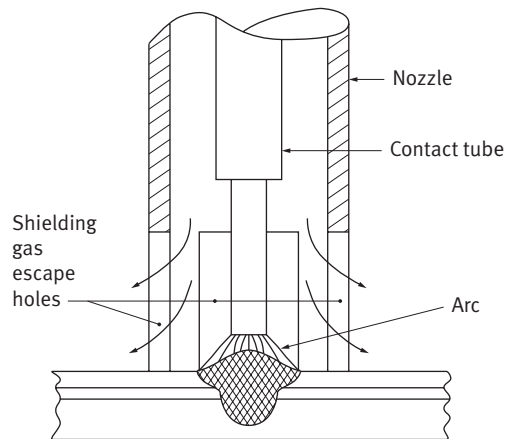

Table 3.1.4 - Recommended MIG welding parameters for austenitic stainless steels

Solid wire diameter (mm)	Welding current (A)		Arc voltage (V)		Ar-O <sub>2</sub> or Ar-CO <sub>2</sub> flowrate (l/min.)
	Short-circuit transfer	Spray transfer	Short-circuit transfer	Spray transfer	
0.8	60 – 80	140 – 210	15 – 17	25 – 28	15
1.0	80 – 120	180 – 250	16 – 18	26 – 29	20
1.2	120 – 150	220 – 290	17 – 20	27 – 30	25



For pulsed GMAW, several types of power sources are available: inverter and transistor power supplies, constant-voltage, that offer independent setting of pulse parameters. More sophisticated power supplies employ synergic controls preprogrammed for a range of wire-feed speeds which provide the optimum combination of the background current and pulse peak current especially useful in the vertical up and overhead positions.

The latest improvement is the “Surface Tension Transfer” (STT) process in which the possibility of adjusting background and peak currents, makes the arc very stable. The current is adjusted in a couple of microseconds, resulting in a tremendous decrease of spatter level (friendly process) and a decrease of fume formation rate (safe process). One of the main applications is in root runs of pipes and more generally vertical up butt welds, overhead welds, and tubular connections.

A variant of MIG welding is the FCAW (Flux Cored Arc Welding) process, in which the electrode wire is composed of a stainless steel sheath filled with a solid flux (fig. 3.1.12), whose role is similar to that of the electrode covering in the manual SMAW (Shielded Metal Arc Welding) process. The principal interest of the FCAW technique is that it combines the advantages of the SMAW method with the high productivity of an automatic or semi-automatic process, due to the possibility of continuously feeding the cored wire. Compared to a conventional solid electrode, the flux both provides a slag cover and enhances productivity. Thus, for a current of about 200 amps, the deposition rate is about 100 g/min for a solid 1.6 mm

diameter wire containing 20% Cr and 10% Ni, compared to about 170 g/min for a flux-cored wire of the same diameter. This large difference is due to the fact that in the flux-cored wire, only the metal sheath conducts electricity, since the core, composed of a mixture of mineral and metal powders, possibly bound in an alkaline silicate, has a high electrical resistivity.

If  $A$  is the cross-sectional area of the sheath,  $L$  the stick-out of wire between the contact tube and the workpiece, and  $I$  the welding current, then the deposition rate  $M$ , in g/min, is given by the relation:

$$M = K_1 + K_2 \cdot I + K_3 \cdot L \cdot I^2 / A$$

where  $K_1$ ,  $K_2$  and  $K_3$  are proportionality coefficients.

*Note:* Confusion often arises between the MIG (Metal Inert Gas) and MAG (Metal Active Gas) welding processes. In fact, in the MIG process, the oxidizing nature of the shielding gas is negligible, whereas it is deliberately enhanced in the MAG process. It is for this reason that only the MIG technique is used for stainless steels, whereas MAG welding is well adapted for plain carbon steels.

However, in the GMAW/MIG process, a low percentage of oxygen ( $O_2$ ) or carbon dioxide ( $CO_2$ ) is often needed in the shielding gas (argon – Ar) to improve both arc stability and wetting by the molten metal. Typical levels are 2%  $O_2$  or 3%  $CO_2$ . Higher levels of  $O_2$  or  $CO_2$  give excessive oxidation of chromium (Cr), manganese (Mn) and silicon (Si) and excessive pick-up of carbon (C) in the weld pool. For example, the carbon content (% C) in the weld metal, which is 0.025% for 2%  $CO_2$  containing shielding gas, could reach 0.04% for 4%  $CO_2$ .

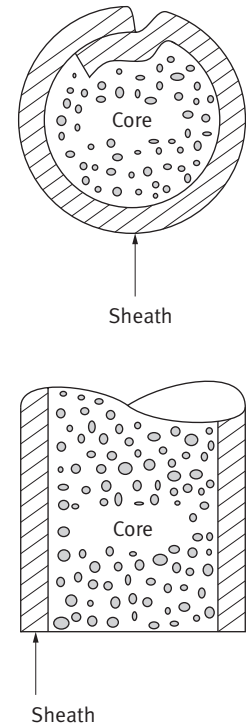

Fig. 3.1.12 - Example of a flux-cored electrode wire

**Plasma Arc Welding (PAW)**

The principle of plasma arc welding is illustrated in figure 3.1.13. The constriction of an electric arc was first attempted in the 1920's by Gerdien and Lotz, whose experimental device confined an arc between two graphite electrodes in the presence of water vapor. However, the concept was not applied to welding until 1955, when the American company Union Carbide filed a patent for a constricted arc system derived from the TIG process. Constriction of the arc produces a stream of ionized gas, called plasma, which is a perfect electrical conductor. The energy available is highly concentrated, and temperatures between 10000 and 20000 K are attained. Welding processes generally employ a "transferred arc" configuration, where the constricted arc is formed between the electrode and the workpiece, whereas other applications more often use a "non-transferred" constricted arc, which is established between the electrode and

a special orifice. Since the plasma jet is extremely narrow, it cannot provide adequate protection for the melt pool, so that it is necessary to add a larger diameter annular stream of shielding gas.

The gases used both for this purpose and for forming the plasma are similar to those employed in TIG welding, namely pure argon, Ar-5% H<sub>2</sub>, Ar-10% H<sub>2</sub> and 25% argon-75% helium. The hydrogen-containing mixtures are recommended for welding austenitic stainless steels, but like in the case of TIG welding, are to be proscribed for ferritic, martensitic and duplex grades. For the latter materials, it is recommended to add nitrogen to maintain the appropriate proportions of austenite and ferrite in the weld.

In manual plasma welding, where the torch is hand-held, the so-called "microplasma" and "mini-plasma" processes are employed for currents between 0.1 and

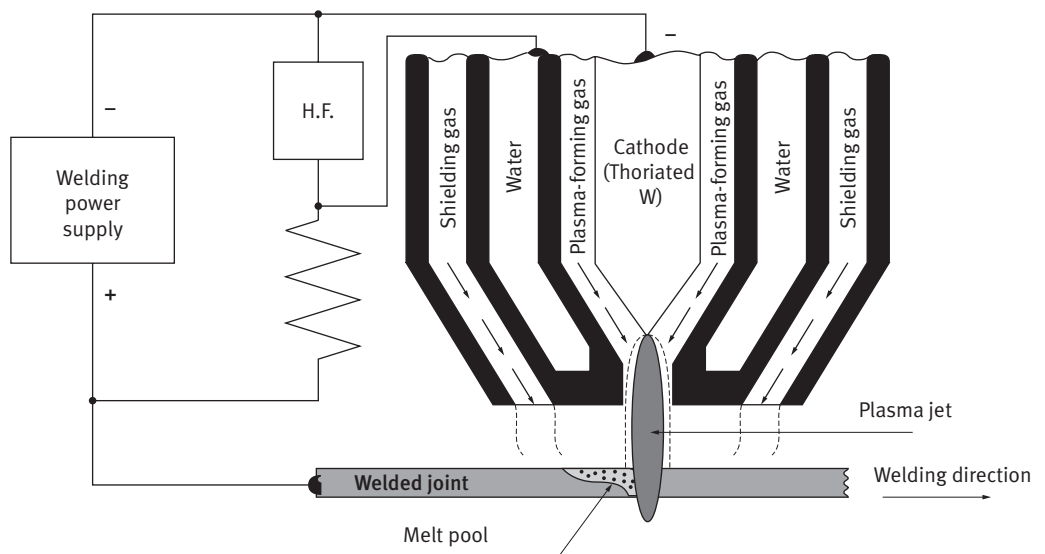

*Fig. 3.1.13 - Principle of keyhole plasma welding (the jet penetrates the workpiece and emerges from the other side)*

15 amps, and the “non-emergent jet” technique for currents between about 15 and 100 amps. In automatic welding, where the torch is mounted on a carriage, the so-called “keyhole” process is employed. Compared to TIG welding, it is important to emphasize that the shape of the nozzle and the position of the electrode with respect to the nozzle orifice play an essential role in constriction of the arc. The major advantage of the PAW process over TIG welding is the remarkable stability of the arc, leading to:

- a “rigid” arc which enables better control of power input;
- greater tolerance to variations in nozzle-workpiece distance, without significant modification to the weldment morphology;

- improved welding with filler metal, due to the greater distance between the nozzle orifice and the workpiece;
- a narrower heat-affected zone (HAZ) and generally faster welding speeds;
- greater tolerance to faulty preparation, particularly in the case of keyhole welding.

Table 10.5 indicates the welding parameters recommended for type X<sub>5</sub>CrNi18-10/ 1.4301 grade austenitic stainless steel.

Table 3.1.5 - Recommended keyhole welding parameters for type X<sub>5</sub>CrNi18-10/1.4301 austenitic stainless steel, for butt welds

Sheet thickness (mm)	Welding current (A)	Plasma gas flowrate (l/min.)	Shielding gas flowrate (l/min.)	Welding speed (cm/min.)
1.5	100	5	30	100
3.0	200	7	30	60
6.0	300	12	30	30
8.0	330	13	30	25

### Submerged Arc Welding (SAW)

The SAW technique was developed simultaneously by the Lincoln Electric Company in the USA and by the B.E. Paton Institute in Kiev before the second world war. It is the automatic version that is the best known, in which one or several wire electrodes are melted, together under an powdered flux which forms a protective molten slag covering. Although the slag has a certain degree of electrical conductivity, melting is essentially due to the electric arc, resistance heating via the slag being only of secondary importance.

In the automatic process (fig. 3.1.14), the welding current can be very high, up to

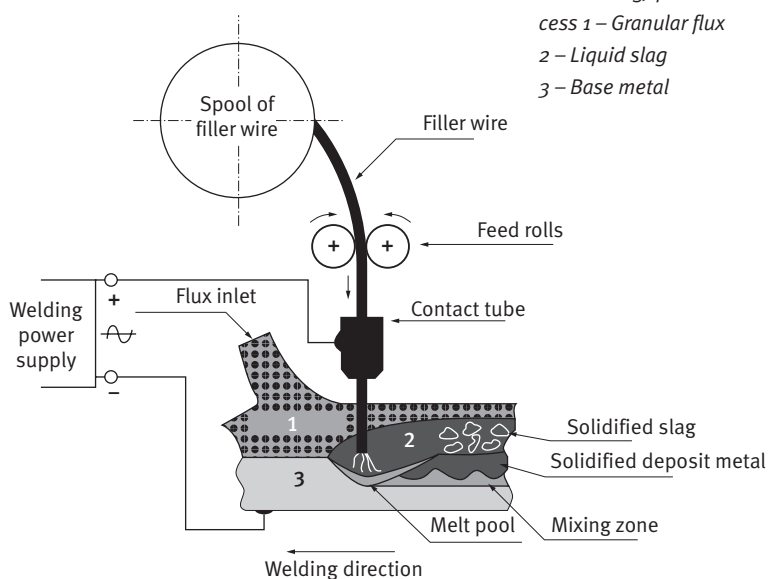

Fig. 3.1.14 - Principle of the SAW (Submerged Arc Welding) process 1 – Granular flux 2 – Liquid slag 3 – Base metal

2000 A per wire, leading to a large power input and consequently a heavy dilution of the base metal by the filler material (up to 80%). The power supply is generally of the DCEP reverse polarity type, and more rarely AC, when several wires are employed simultaneously, in order to avoid arc blow phenomena. For both DC and AC generators, the electrode wire pay-out speed must be equal to the melting rate in order to obtain a perfectly stable arc. This is obtained by the use of feed rolls commanded by a motor-reducing gear system with servocontrolled speed.

The choice of welding flux is also important, five types being available:

- Type 1: manganese silicate
- Type 2: calcium silicate
- Type 3: alumina-rutile
- Type 4: lime alumina
- Type 5: lime fluoride

For welding stainless steels, type 5 fluxes are most widely used, their typical composition being  $25\% \leq \text{CaO} + \text{MgO} \leq 40\%$ ,  $\text{SiO}_2 < 15\%$ ,  $20\% \leq \text{CaF}_2 \leq 35\%$ . They exist in two forms, produced either by melting or bonding. Fused fluxes are produced by heating to temperatures of the order of 1600–1700 °C, and are converted to powder form either by atomization on leaving the melting furnace, or by crushing and screening the solidified bulk material. Bonded fluxes are produced from raw materials of appropriate grain size, bonded together with an alkali silicate binder. The mixture obtained is dried, then mechanically treated, to obtain the desired final particle size. This intermediate product is then baked at a high temperature, which may exceed 700 °C in certain cases.

In the as-delivered condition, the fluxes are perfectly dry, giving diffusible hydrogen contents less than 5 cm<sup>3</sup>/100 g of metal deposited. In order to prevent moisture pick-up, it is recommended to store the flux at a temperature about 10 °C higher than that of the workshop, in an atmosphere whose relative humidity does not exceed 50%. If moisture pick-up is feared or suspected, it is useful to bake the powder at 300 °C for at least two hours. For baking to be efficient, the flux must be spread out on metal trays in a layer no more than 40 mm thick. The grain size of the flux is defined in terms of the sieve mesh dimensions. The mesh number is the number of mesh openings per unit length (usually per inch). The standard Tyler scale generally used for woven metal sieves starts at a value of 200 mesh, corresponding to 200 openings per linear inch (25.4 mm). The correspondence between mesh number and the (square) hole dimension is given in Table 3.1.6.

*Table 3.1.6 -  
Correspondence  
between standard Tyler  
mesh number and hole  
dimensions (side of  
square)*

Mesh number	Mesh opening (side of square – mm)
8	2.362
12	1.397
14	1.168
16	0.991
20	0.833
42	0.350
60	0.246
100	0.147
150	0.104
200	0.074

Two rules must be observed when choosing the grain size. First of all, except for horizontal welding positions (e.g. horizontal fillet, horizontal butt welds), it is recommended to use a fine grain size. Secondly, for procedures involving high welding currents, it is also recommend-

ed to use a fine grain size. The flux used plays an important role in the transfer of alloying elements from the filler metal to the melt pool, the effect being determined by the basicity index of the slag, which can be conveniently expressed by S.S. Boniszewski's formula:

$$B = \frac{[\text{CaO} + \text{MgO} + \text{Na}_2\text{O} + \text{K}_2\text{O} + \text{Li}_2\text{O} + \text{CaF}_2 + 1/2(\text{MnO} + \text{FeO})]}{[\text{SiO}_2 + 1/2(\text{Al}_2\text{O}_3 + \text{TiO}_2 + \text{ZrO}_2)]}$$

The higher the index, the greater the transfer of alloying elements. Silica,  $\text{SiO}_2$ , reacts with chromium, retaining it in the slag in the form of oxides. Rutile,  $\text{TiO}_2$ , does the same, albeit to a lesser extent. With fluxes whose basicity index is less than 1, up to 30% of the chromium can be oxidized in this way. On the contrary, with high basicity fluxes ( $B > 3$ ), chromium losses will be less than 10%, and can be readily compensated by additions of ferrochrome in the flux. Nickel and molybdenum have a lower tendency to oxidize, and therefore have a good transfer coefficient in the arc.

Since the SAW process is used mainly for thick austenitic stainless steel sheet, particular care must be taken to avoid the formation of sigma phase due to the use of

high welding energies. This is especially the case for 25% Cr-20% Ni alloys, but also for 18% Cr-9% Ni grades with high ferrite contents. In multipass welding, where the temperature range 650–900 °C is crossed several times, the risk of sigma phase formation is considerably enhanced. Subsequent solution annealing at 1050 °C is then highly recommended.

The recommended welding parameters as a function of electrode wire diameter and flux grain size are indicated in Table 3.1.7.

*Table 3.1.7 - Recommended welding parameters as a function of electrode wire diameter and flux grain size*

Electrode wire diameter (mm)	Welding current (A)	Arc voltage (V)	Flux grain size (mesh)
2.4	250 – 500	22 – 32	8 × 48
3.2	300 – 700	23 – 36	14 × 48
4.0	400 – 900	24 – 40	16 × 150
5.0	500 – 1100	25 – 43	42 × 200

### Shielded Metal Arc Welding (SMAW)

Although the SMAW process is very old, since the first applications were reported by Kjellberg in 1907, it remains widely used due to its great flexibility and simplicity of implementation. As illustrated schematically in figure 3.1.15, the electrode consists of a metal core covered with a layer of flux. The core is usually a solid stainless steel wire, but in certain very special cases it can be a cored wire or a solid mild steel wire (“synthetic” electrodes). The covering, which plays an essential role in the process, is extruded onto the core, and gives each electrode its specific “personality”. It serves three main functions – electrical, physical and metallurgical. The electrical function is related to initiation and

stabilization of the arc, while the physical influence concerns the viscosity and surface tension of the slag, which control the transfer of metal droplets, the effective shielding of the melt pool and its wettability, and the aptitude for in situ welding (e.g. in the vertical up butt and horizontal butt welds). The metallurgical role involves chemical exchanges between the melt pool and the slag, i.e. refining of the deposited metal. The covering contains a certain amount of calcium carbonate ( $\text{CaCO}_3$ ), which dissociates in the arc at about  $900^\circ\text{C}$ , to form  $\text{CaO}$  and  $\text{CO}_2$ , the latter ensuring protection of the arc zone. Finally, as in the SMAW process applied for to mild steel, in addition to refining reactions, the slag enables the addition of elements not contained in the core, or present only in small amounts.

Rutile-covered electrodes can be employed in both the AC and DC modes, whereas lime coverings are used essentially in the DCEP reverse polarity mode. The recommended welding parameters for electrodes depositing either a 17% Cr or 19% Cr-10% Ni composition are indicated in Table 3.1.8.

Fig. 3.1.15 - Principle of the (S.M.A.W.: Shielded Metal Arc Welding) process  
 1 – Solidified deposit metal  
 2 – Mixing zone  
 3 – Flux covering  
 4 – Electrode core

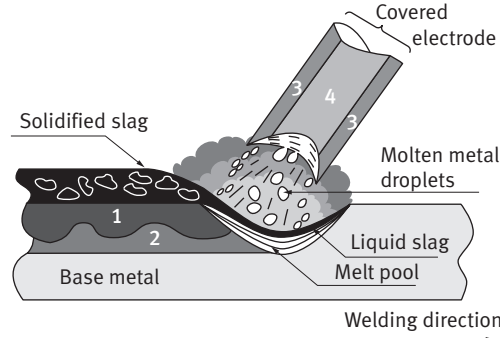

Table 3.1.8 - Recommended SMAW parameters as a function of electrode core diameter

Core diameter (mm)	Welding current (A)	
	17% ferritic weld deposit	19% Cr-10% Ni austenitic weld deposit
2.5	50 – 100	40 – 90
3.2	80 – 110	60 – 100
4.0	110 – 160	90 – 150
5.0	150 – 230	130 – 220

### Electrical resistance welding

#### Resistance Spot Welding (RSW)

This process is still extensively used and is particularly suited to the welding of thin stainless steel sheets. Melting is induced by resistance heating due to the passage of an electric current through the workpiece materials at the joint. Five different stages are generally distinguished in the spot welding process (fig. 3.1.16), namely, positioning of the sheets to be joined, low-

ering of the upper electrode and application of the clamping force, welding with a low voltage alternating current, producing a heating energy  $W$  (joules) =  $R$  (ohms)  $I^2$  (amps)<sup>2</sup>  $t$  (seconds), holding of the clamping force or application of an additional forging force, and finally, raising of the upper electrode before proceeding to the next cycle.

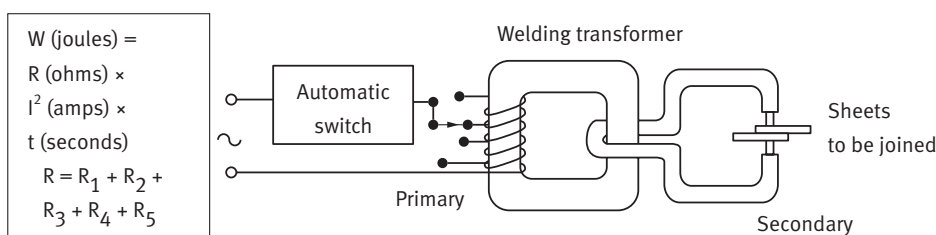
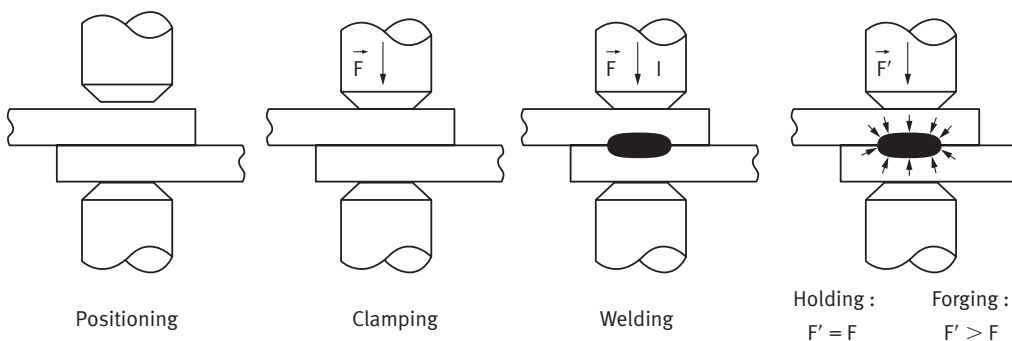
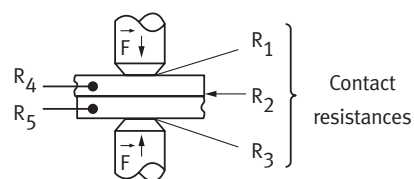

Fig. 3.1.16 - Principle of resistance spot welding

$R_4$  and  $R_5$ : Resistances of the workpiece sheets (depend on their resistivities)  
 $R_2$ : Contact resistance between the 2 sheets depends on their surface conditions and the clamping force  $\vec{F}$   
 $R_1$  and  $R_3$ : Contact resistances between the electrodes and the sheets





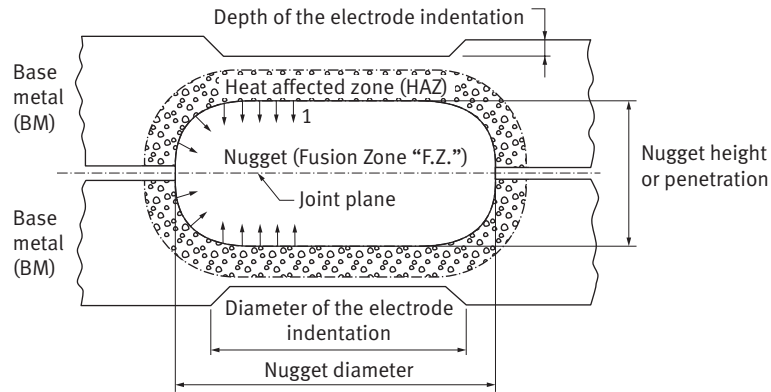

Fig. 3.1.17 - Schematic representation of a weld spot and nugget formation. 1 – Schematic representation of dendrite formation

With regard to the electrode materials, in the case of stainless steels, the best combination of low resistivity and high mechanical strength is obtained with copper-cobalt-beryllium alloys. The electrode points are generally in the form of a truncated cone with an apex angle of 120°. Formation of the weld nugget (fig. 3.1.17) depends on the welding current and its duration, and on the clamping force applied by the electrodes. The welding parameters recommended for 18% Cr-9% Ni austenitic stainless steel and stabilized 17% Cr ferritic grades are indicated in Table 3.1.9.

The parameters given in Table 3.1.9 must be optimized to allow for the surface condition (pickled-2D, 2B, bright annealed-2R), which has a strong influence on the interface resistance, which in turn plays a decisive role in nugget formation. Contrary to other fusion welding processes, in resistance spot welding, the melt pool cannot be controlled visually. The only defects perceptible to the eye are an excessive electrode indentation and surface spatter. However, a simple, albeit destructive, inspection method is the so-called “peel test”, which gives a rapid indication of the quality of the weld spot.

Table 3.1.9 - Recommended resistance spot welding parameters for 18% Cr-9% Ni austenitic stainless steel and stabilized 17% Cr ferritic grades

Sheet thicknesses (mm)	Electrode tip diameter (mm)	Electrode clamping force (daN)	Welding current (A)	Welding time (No of periods)
18% Cr - 9% Ni austenitic grades				
0.5	3.0	170	3500	3
0.8	4.5	300	6000	4
2.0	6.0	650	11000	8
Stabilized 17% Cr ferritic grades				
0.5	3.0	150	4000	3
0.8	4.5	250	7550	4

**Resistance Seam Welding (RSEW or SW)**

The principle of resistance seam welding is similar to that of spot welding, except that the process is continuous. The major difference is in the type of electrodes, which are wheels equipped with an appropriate drive system (fig. 3.1.18 and 3.1.19). Compared to spot welding, where the principal process parameters are the welding current, the application time and the electrode clamping force, additional factors to be considered in seam welding are the use of a modulated or pulsed current and the welding speed (the linear wheel velocity entrains the sheet travel displacement). The most widely used material for the electrode wheels is a copper base alloy containing cobalt and beryllium to improve the mechanical strength. The wheel edges usually have either a double chamfer or a convex profile. The welding parameters recommended for Fe-Cr-Ni austenitic grades are indicated in Table 3.1.10.

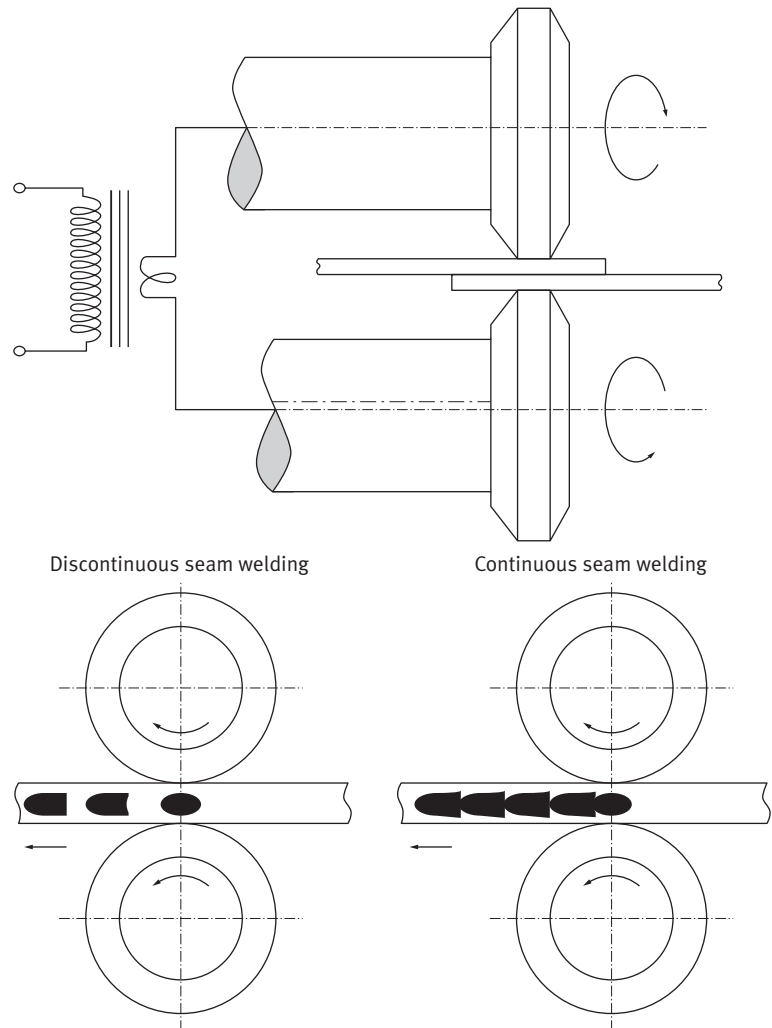
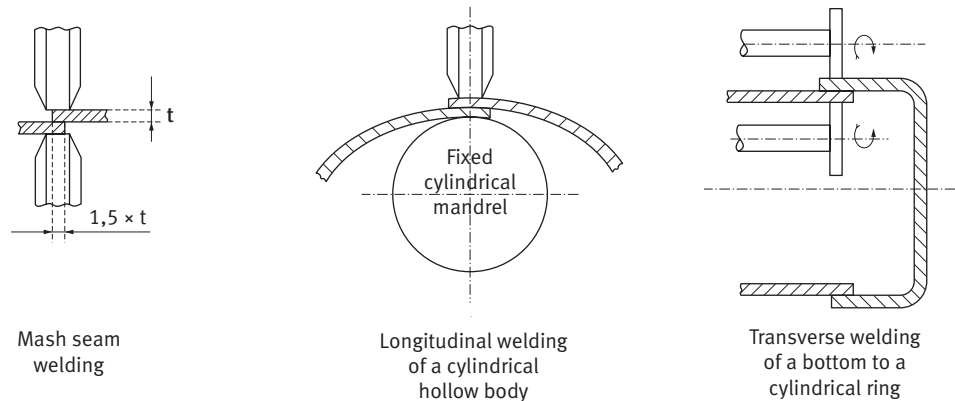

Fig. 3.1.18 - Principle of resistance seam welding

Fig. 3.1.19 - Typical assemblies produced by resistance seam welding



Mash seam welding

Longitudinal welding of a cylindrical hollow body

Transverse welding of a bottom to a cylindrical ring

Table 3.1.10  
-Recommended resistance seam welding parameters for 18% Cr - 9% Ni austenitic stainless steels

Sheet thicknesses (mm)	Wheel thicknesses (mm)	Clamping force (daN)	Welding time (periods)	Rest time (periods)	Welding current (A)	Welding speed (cm/min.)
0.5	3.0	320	3	2	7900	140
0.8	4.5	460	3	3	10600	120
1.5	6.5	800	3	4	15000	100
2.0	8.0	1200	4	5	16700	95
3.0	9.5	1500	5	7	17000	95

Table 3.1.10 shows the necessity of modulating the welding current. The distance between successive nuggets is determined by the pulse frequency (welding time and rest time) and the welding speed (tangential wheel velocity). The welding time is chosen as a function of the steel grade and the sheet thicknesses, while the rest time is determined by the welding speed.

In both spot and seam welding, the major advantages of resistance heating are the limited modification of the microstructure in the heat affected zones, the virtual absence of surface oxidation if the sheets are correctly cooled (by streaming cold water), and the very small distortion of the sheets after welding.

**Variants of resistance welding**

*Upset welding (UW)*

Upset welding, or resistance butt welding (fig. 3.1.20 and 3.1.21) is used essentially for long products (rods, bars, tubes, shaped sections, etc.). The two end faces to be joined must make excellent contact to facilitate passage of the heating current, which is fed to the workpiece components through the fixed and mobile clamp. The current produces intense heating in the region between the clamps, with a local excess temperature at the interface, due to the additional contact resistance. When the temperature is sufficient, an upsetting force is applied between the two clamps, in order to induce forge welding without melting. Since the upsetting force is high,

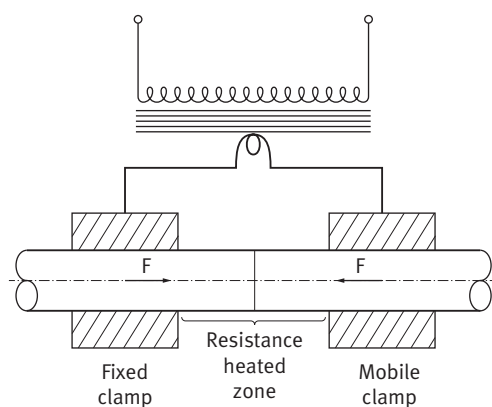

Fig. 3.1.20 - Principle of upset welding

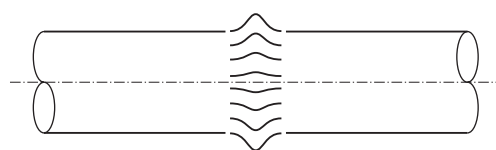

Fig. 3.1.21 - Upset welding of a cylindrical bar

the cross-section of the parts must be sufficiently large to avoid buckling. After welding, a marked swelling is observed in the weld zone. This process is very old, being described by Elihu Thomson in 1887, but has now been largely replaced by flash butt welding, which is much more flexible.

**Flash welding (FW)**

Although apparently similar to upset welding, flash butt welding is in fact quite different (fig. 3.1.22, 3.1.23 and 3.1.24). Indeed, during upset welding, it had been observed that when the abutting surfaces were not in perfect contact, the current passed only in a few small areas, leading to intense local heating and rapid melting, creating arcs which violently expulse the molten metal out of the joint due to the associated magnetic fields (the flashing phenomenon). The important process parameters are the welding current and the voltage, which must be sufficient to cause flashing, the instantaneous flashing speed, which is proportional to the metal consumption and compensated by the displacement of the mobile clamp, the duration of flashing, and the final upset forging stage. The roughness of the initial facing surfaces must be such that the contact points are sufficiently numerous and well distributed to produce uniform flashing across the whole of the joint area (fig. 3.1.23). After upset forging, the joint profile should show the characteristic three-finned profile indicative of a successful welding operation (fig. 3.1.24).

In spite of its limitations, upset welding is still used for joining coils to facilitate continuous wire drawing up to 8.0 mm diameter.

Fig. 3.1.22 - Principle of flash butt welding

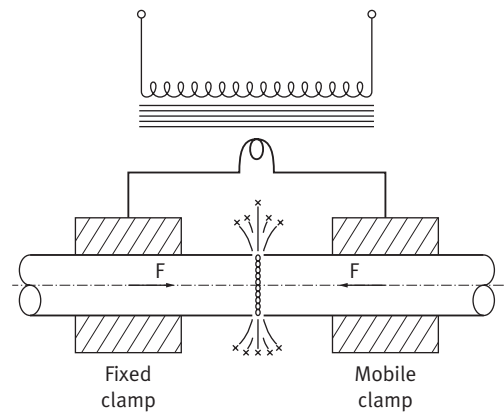
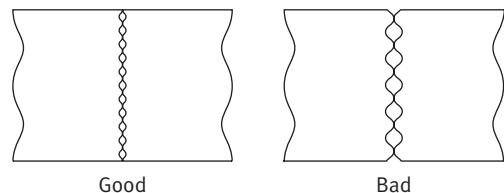
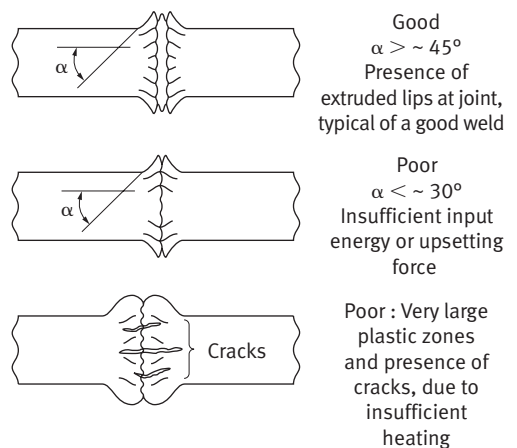

Fig. 3.1.23 - The asperities on the 2 facing surfaces must be symmetrical with respect to the plane of the joint.



– An optimum flashing energy produces numerous small craters (left),  
 – while an excessive flashing energy leads to fewer and deeper craters (right).

Fig. 3.1.24 - Effect of welding parameters on the final weld profile



### High Frequency Induction Welding (HFIW)

High frequency induction welding (fig. 3.1.25) is essentially used for making tubes from strip. The process is performed on a continuous line in which the welding station is preceded by a multiple roll forming system. On leaving the last rolling stand, the tube comprises a longitudinal slit which is closed by welding. The joint is formed by solid-solid contact, with intermediate melting, as the strip edges are brought together by a pair of horizontal rolls (squeezing rolls). Due to the skin effect, the induced HF current (140 to 500 kHz) follows paths of minimum impedance, concentrating the heating at the edges (fig. 3.1.25).

In the case of ferritic stainless steels, this high productivity process avoids the grain coarsening phenomenon to which these grades are susceptible. In this case, welding powers between 150 and 300 kW are employed, depending on the tube diameter, the welding speed varying with the machine from 50 to 90 m/min.

Fig. 3.1.25 - Principle of HF induction welding

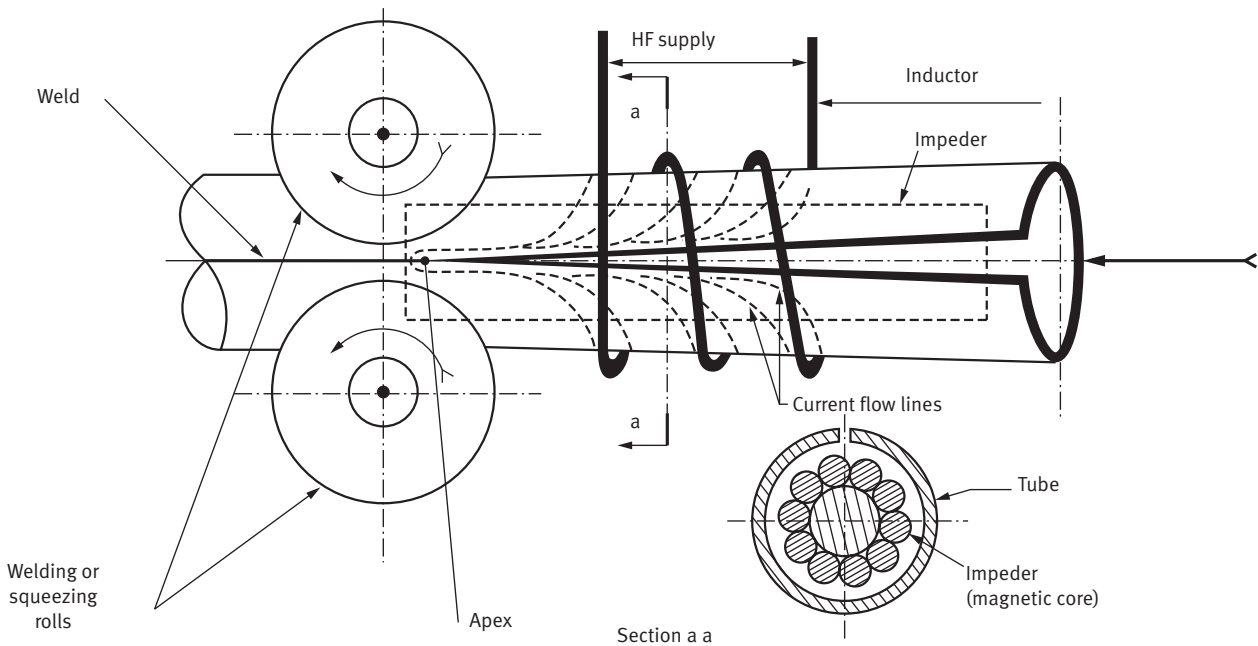

### Laser Beam Welding (LBW)

The laser effect (Light Amplification by Stimulated Emission of Radiation) was discovered in the optical wavelength range by Maiman in 1958. The possibility of using a laser beam as a small area contact-free high intensity power source immediately appeared attractive for welding applications, particularly since no vacuum is required, contrary to electron beam welding. The set-ups employed for solid state and gas laser welding are illustrated schematically in figures 3.1.26 and 3.1.27 respectively.

ly. The continuous power levels available are particularly high for carbon dioxide lasers, although it must be remembered that the effective welding power depends on the reflectivity of the work-piece material for a given incident wavelength.

The sources most widely used for welding purposes are CO<sub>2</sub> gas lasers and solid state yttrium-aluminum garnet (YAG) lasers. YAG lasers are preferred for welding thin stainless steel sheets (< 1.5 mm) in the pulsed mode. So-called CO<sub>2</sub> lasers, in which

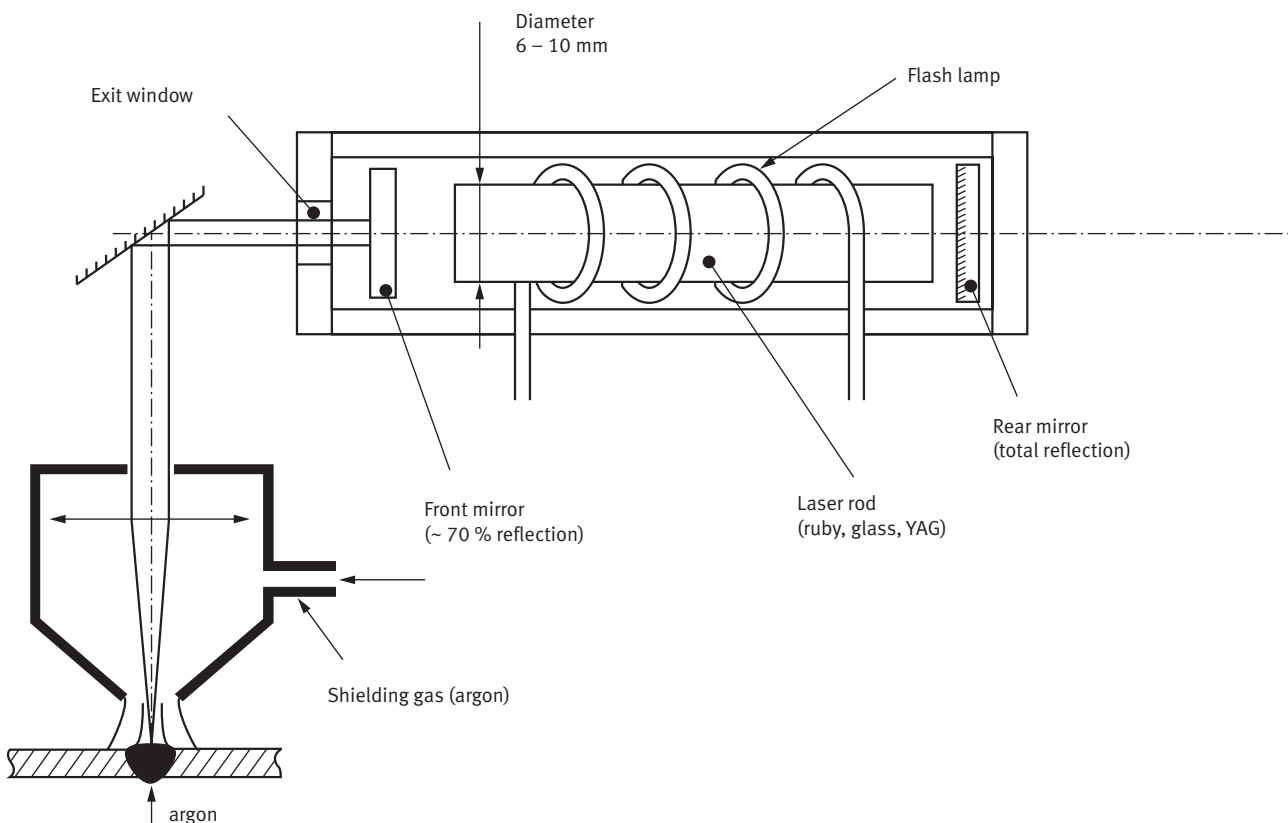

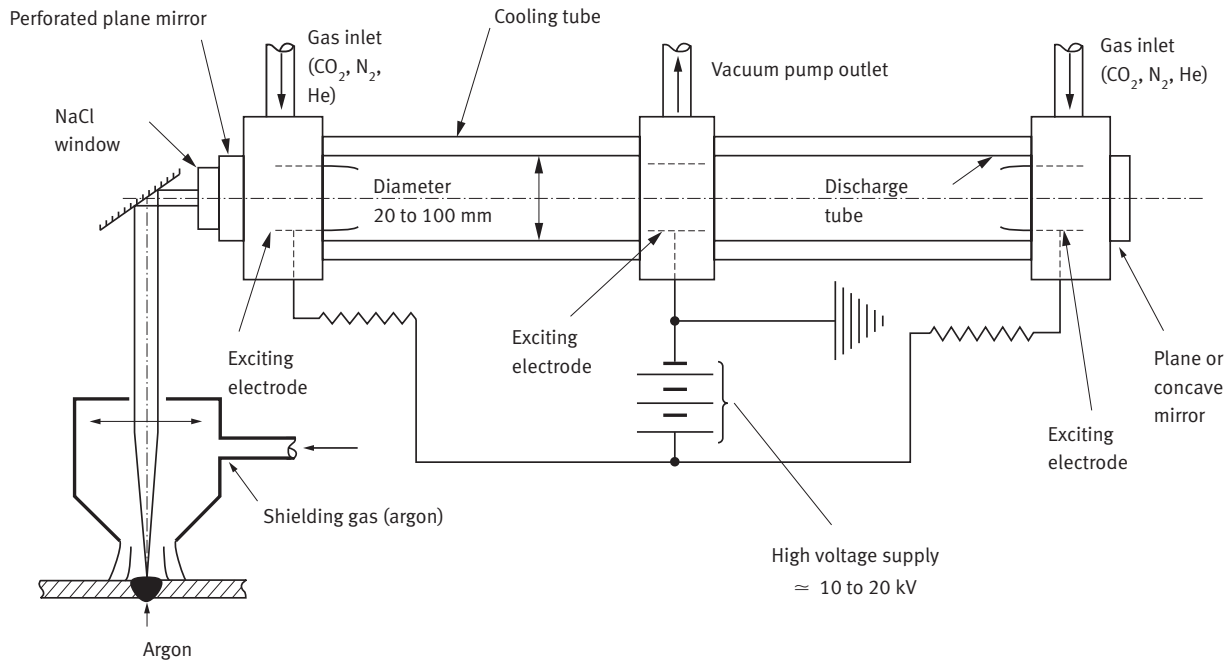

Fig. 3.1.27 - Principle of a CO<sub>2</sub> (CO<sub>2</sub>, N<sub>2</sub>, He) laser used for welding

the lasing gas is in fact a CO<sub>2</sub>-N<sub>2</sub>-He mixture, are better adapted for the welding of thicker stainless steel sheets (1.5 to 6.0 mm).

As in high frequency induction welding, this process is widely used for the production of longitudinally welded tubes. With a power of about 6 kW, a 2 mm thick strip of

stabilized 17% Cr ferritic stainless steel can be welded at a speed of the order of 7 m/min, and since the thermal cycle is very brief, grain coarsening in the heat affected zone is extremely limited.

**Other welding processes**

It is impossible to give an exhaustive coverage of all the welding processes applicable to stainless steels. One of the most noteworthy is electron beam welding, which must be performed under vacuum, but enables the production of highly precise joints in both thin and heavy gage materials. Finally, friction butt welding can sometimes be useful for joining long products (bars). In this process, one of the components to be joined

is rapidly rotated and then brought into contact with the other fixed one under controlled pressure. The resulting intense friction causes welding due to limited surface melting and diffusion bonding.



## Finishing treatments for welding austenitic stainless steels

### *Pickling*

With certain welding processes, the welded joint (including the heat affected zone) becomes covered with a coloured oxide which it is essential to remove in order to be able to restore passivity. Several techniques can be employed.

#### *Pickling baths*

- 52% nitric acid (36° Baumé) : 100 l
- 65% hydrofluoric acid : 20 l
- or sodium fluoride : 30 kg
- water : 900 l

The immersion times at 20 °C generally vary between 1 and 3 hours. The bath temperature and immersion time must be carefully controlled to prevent corrosion of the metal. After pickling, the parts must be abundantly rinsed with chlorine-free water.

#### *Pickling pastes and gels*

The use of pastes or gels enables the treatment to be limited to the weld zones. Their compositions vary, but often contain nitric acid. The paste or gel is spread on with a paint brush, and the area is then brushed with a stainless steel wire brush. After pickling, the affected area is rinsed with chlorine-free water.

### *Passivation*

After pickling, the metal is unprotected and a new passive layer must be formed to restore its corrosion resistance. To a certain extent, this occurs spontaneously after pickling and rinsing. However, in order to ensure the quality and speed of passivation, an immersion in a passivating bath is recommended.

#### *Passivating baths*

The parts are immersed in an acid bath with the following approximate composition:

- 52% nitric acid (36° Baumé) : 250 l
- water : 750 l

The immersion times at 20 °C generally vary between 15 minutes and 1 hour. After passivation, the parts are carefully rinsed with chlorine-free water.

#### *Passivating pastes and gels*

Pastes and gels are used for local passivation of the weld zones. The nitric acid based product is spread on the surfaces to be treated, then totally eliminated by brushing with a stainless steel or nylon brush, followed by rinsing with chlorine-free water.

### *Decontamination*

The different sheetworking operations (shearing, bending, forming, etc.) can leave iron-rich particles on the surface, which it is essential to remove. Although their aim is different, the methods used for decontamination are the same as those for passivation.

## 3.2 Brazing and soldering

### Introduction

Brazing and soldering are techniques for joining metallic components in the solid state by means of a fusible filler metal with a melting point well below those of the base metals. Soldering employs soft filler al-

loys with melting points less than 450 °C, whereas brazing alloys are harder and melt at higher temperatures. Since the base metals remain in the solid state, it is essential to obtain perfect wetting by the molten filler material (fig. 3.2.1).

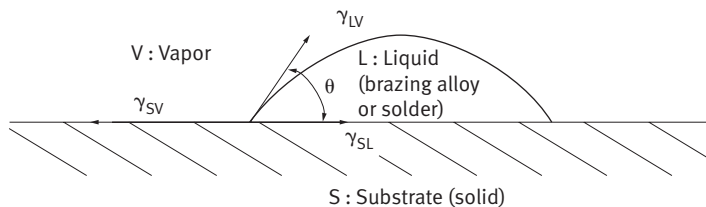

Contact angle :  $\theta < 90^\circ \rightarrow$  good wetting of the substrate by the molten brazing alloy or solder

Young's model :  $\gamma_{SV} = \gamma_{SL} + \gamma_{LV} \cos\theta$

$\gamma_{LV}$  : Surface tension of the liquid brazing alloy or solder in equilibrium with its vapor (mN/m)

$\gamma_{SV}$  : Surface tension of the solid substrate in equilibrium with the brazing alloy solder vapor (mN/m)

$\gamma_{SL}$  : Interface tension between the liquid brazing alloy or solder and the solid substrate (mN/m)

Fig. 3.2.1 - Wetting of the substrate by the brazing alloy or solder

### Brazing

#### Heating process

The heating process employed depends both on economic considerations and on the type of assembly to be produced. Whatever the technique chosen, it is recommended to observe the following two basic rules:

a) Heating must be rapid to ensure uniform melting of the brazing alloy rather than liquation, and also to prevent microstructural changes in the base metals.

b) The joint must be heated to a uniform temperature slightly above the liquidus of the brazing alloy employed.

The principal heating processes employed are:

- oxyacetylene torch heating;
- high frequency (HF) and medium frequency (MF) induction heating;
- heating in a continuous or muffle furnace;
- immersion heating;
- heating with a soldering iron (for solders, not for brazing).

#### Oxyacetylene torch heating

The parts to be joined must be previously protected by a flux, generally in the form of paste. The flame must be neutral towards the base metal, i.e. neither carburizing nor

oxidizing. When the brazing alloy has a wide melting range ( $> 50^\circ\text{C}$ ), it is important to heat the parts to be joined to a uniform temperature to avoid liquation (partial melting).

## Induction heating

This is probably the most suitable heating process for the series brazing of parts with complex geometries. However, it is absolutely essential that the shape of the induction coil is well adapted to those of the parts to be joined. This is also true for the shape of the brazing material, which may be in the form of rings, disks, etc. Induction heating of both the base metals and brazing alloy is rapid, typically taking about 30 seconds. Either medium frequency (several tens of kHz) or high frequency (300-500 kHz) generators are used, MF heating being more appropriate for medium to heavy gage components, whereas HF induction is to be preferred for thinner parts. Indeed, the depth of penetration of the heating depends on the frequency, and is given by the formula:

$$p = k \times \sqrt{(\rho/\mu \times f)}$$

where  $p$  is the depth of penetration,  $f$  is the frequency,  $\mu$  is the magnetic permeability,  $\rho$  is the electrical resistivity and  $k$  is a proportionality coefficient. Practically 90% of the heat is generated in the surface layer of thickness  $p$ . Since the magnetic permeability  $\mu$  and the electrical resistivity  $\rho$  of the base metals are essentially constant, the penetration  $p$  is inversely proportional to the square root of the frequency. Induction heating is more efficient for parts with circular symmetry. The most characteristic applications employ helicoidal, spiral or circular external coils or helicoidal internal ones (fig. 3.2.2). For relatively low melting point brazing alloys, heating can be performed in air, but it is necessary to use a protective pickling flux, all traces of which must imperatively be removed after brazing. Heating in a neutral or reducing atmosphere minimizes oxidation.

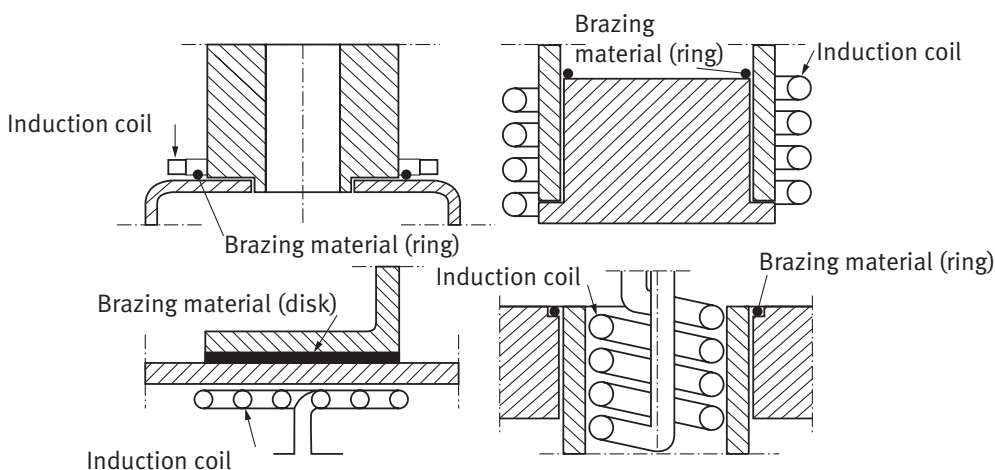

Fig. 3.2.2 - Induction systems for brazing

### Furnace heating

The austenitic stainless steels (Fe-Cr-Ni alloys) can be readily brazed. The brazing materials employed are either copper-base, silver-copper-zinc-tin, nickel-chromium-boron or nickel-chromium-silicon alloys. Ferritic stainless steels (Fe-Cr alloys) are commonly brazed with silver-copper-tin-nickel, silver-copper-zinc-nickel or silver-copper-zinc-tin alloys, using similar procedures to those for austenitic grades. The major difference for ferritic materials is the need to scrupulously respect the recommended brazing temperature and time, in order to avoid excessive grain growth and/or chromium carbide precipitation.

In a continuous or muffle furnace, heating is produced either by combustion of a hydrocarbon fuel or by electrical resistances. In order to avoid oxidation of the stainless steel, the brazing operation itself is performed under vacuum or in a controlled atmosphere, preferably of a reducing nature, such as dry hydrogen or a hydrogen-nitrogen mixture, generally produced by cracking ammonia. In order to ensure a low oxidizing potential, the moisture levels must correspond to dewpoints of at least  $-55^{\circ}\text{C}$ , and if possible  $-70^{\circ}\text{C}$ . Depending on the brazing alloy employed, the furnace temperature may be between 600 and  $1200^{\circ}\text{C}$ , with heating rates of the order of 15 to  $20^{\circ}\text{C}/\text{min}$ .

Cooling may be performed initially under vacuum, then at an accelerated rate, in either a reducing atmosphere (austenitic grades) or a neutral argon atmosphere (ferritic grades), in order to avoid oxidation. In all cases, the holding time at the brazing temperature

must not be extended beyond that strictly necessary for the joining operation, involving good wetting of the base metals by the braze material, a few minutes generally being sufficient.

The use of stabilized ferritic stainless steels is currently undergoing rapid development. Brazing of these materials under vacuum or protective gas requires specific procedures and filler products, since the stabilizing elements can have a detrimental effect on wettability. The atmospheres most commonly employed in this case are pure hydrogen, hydrogen-10% nitrogen, hydrogen-25% nitrogen and vacuum. Of the two stabilizing elements most frequently used, niobium has virtually no influence on wetting behaviour, whereas titanium has a pronounced negative effect, particularly in concentrations exceeding those strictly necessary for stabilization. The new brazing alloys used for these grades are Cu-30% Mn-5% Ni and Cu-30% Mn-5% Ag alloys, applied at temperatures of the order of  $1000^{\circ}\text{C}$ , either in a vacuum of  $10^{-5}$  torr, or under an atmosphere of pure hydrogen with a dewpoint of  $-60^{\circ}\text{C}$ .

The heating techniques summarized above are essentially applicable only to brazing, the corresponding brazing alloys being indicated in Table 3.2.1 for the three major families of stainless steels, i.e. austenitics, ferritics and martensitics.

## Soldering

Two types of solder are used for stainless steels, corresponding to either almost pure tin, with a melting point of about 230 °C and a tin-silver alloy with a melting range of 215–225 °C (fig. 3.2.3). Austenitic alloys of the 18% Cr-9% Ni type have excellent solderability, while 17% Cr ferritic grades require prior surface preparation. For both austenitic and ferritic alloys stabilized with titanium and/or niobium, soldering is somewhat more difficult without careful surface conditioning. Indeed, as in any wetting phenomenon, surface finish has a decisive influence. A pickled finish (2D) is more suitable than either a 2B surface finish, or especially a bright annealed finish (2R), Table 4.1.2.

Soldering is generally performed with an electric soldering iron, but an oxyacetylene torch may also be employed. Soldering requires the use of a suitable flux, which in the case of stainless steels must not contain chlorine, whose corrosive effect is well

established. Orthophosphoric acid based fluxes give excellent results and avoid the risks associated with chlorides. In all cases, the stainless steel surfaces must be thoroughly rinsed after soldering to remove all traces of flux.

An excellent way to obtain virtually perfect soldered joints is to use austenitic or ferritic stainless steels with controlled surface roughness. These products are widely used for roofing and accessories in the building industry, and have a matt appearance, often greatly appreciated by architects.

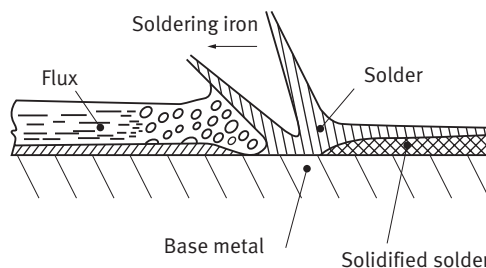

Fig. 3.2.3 - Principle of soldering

Table 3.2.1 - Principal brazing alloys used for stainless steels

Classification ASTM - AWS	EN 1044 short code	Nominal composition (wt. %)									Brazing temperature (°C)	Base metal*			
		Ag	Cu	Ni	Zn	Cr	Si	Sn	Cd	Others		A	F	M	
B <sub>Ag</sub> 1	Ag 302	45	15		16						24	620 / 730	X		
B <sub>Ag</sub> 1 a	Ag 301	50	15.5		16.5						18.0	630 / 760	X		
B <sub>Ag</sub> 4		40	30	2	28							780 / 900	X		X
B <sub>Ag</sub> 13		54	40	1	5							860 / 970	X	X	X
B <sub>Ag</sub> 21		63	28.5	2.5						6		800 / 900	X	X	X
B <sub>Ag</sub> 26		25	38	2	33						Mn=2	800 / 900	X		
B <sub>Ni</sub> 1	Ni 101			74.1		14	4.0				B=3.4 Fe=4.5	1070 / 1200	X		
B <sub>Ni</sub> 2	Ni 102			82.4		7	4.5				B=3.1 Fe=3.0	1010 / 1180	X	X	
B <sub>Ni</sub> 5	Ni 105			71		19	10					1070 / 1200	X	X	

\* A: austenitic, F: ferritic, M: martensitic.

### 3.3 Adhesive bonding

#### Introduction

Adhesive bonding can be employed to reinforce mechanical joints produced by bolting, riveting, clinching, etc., and can also be used in its own right for joining thin stainless steel sheets when it is essential not to modify the surface appearance. Adhesive bonding operations do not modify the joint geometry and cause no microstructural changes in the metallic alloys. Correctly designed adhesively bonded joints have excellent fatigue strength. In certain cases, the adhesive layer can provide thermal and electrical insulation and may also absorb vibrations, decreasing noise levels. The use of adhesive bonding frequently enables significant weight savings, which are particularly

advantageous in transport applications. These undeniable advantages are offset by the mechanical properties of the joints, which are generally weaker than those produced by welding or brazing, together with a temperature limit usually of about 200 °C and a certain sensitivity to moisture. Finally, for successful adhesive bonding, it is essential to work with perfectly clean and well prepared surfaces.

#### The major families of adhesives

An adhesive is a complex product, each of whose many components has a specific function (plasticizer, hardener, solvent, etc.).

These constituents are mixed according to various formulations designed to produce different property combinations.

#### Classification according to physical type

The physical forms of adhesives may be liquids, pastes, powders, tapes, films, etc.

##### *Liquid adhesives*

These materials are often solvated and must then be dried. In this case, they are supplied either as aqueous or organic solvent solutions or in the form of emulsions. They may also be hot or cold polymerizing single- (1 K) or two-component (2 K) resins.

##### *Pastes and mastics*

These products are single- (1 K) or two-component (2 K) resins which ensure adherence and sealing after drying and/or crosslinking (i.e. curing, setting, hardening).

##### *Powdered or granulated adhesives*

These products are solid at ordinary temperatures and acquire their adhesive properties by heating.

### ***Adhesive films and tapes***

Single or double-sided adhesive films/tapes are available, in which a synthetic support is impregnated with adhesive on one or both sides. Alternatively, the

adhesive itself may be transferred from a support onto the surface to be bonded, or the entire film may polymerize by heating to produce bonding.

### **Classification according to the setting mechanism**

According to this classification, three major categories of adhesives can be distinguished, corresponding to thermosets, thermoplastics and cold bonding materials, elastomers being affiliated to the latter group.

#### ***Thermosetting adhesives***

In these products, the setting or curing kinetics are very slow at ambient temperature and are accelerated by heating or by adding a hardener prior to use. They include phenolics, epoxies (epoxy plus polyamides, nylon, silicone, polysulfides, phenolics), acrylics (cyanoacrylates, anaerobic and modified acrylics) and aminoplastics (urea-formol).

#### ***Thermoplastic adhesives***

These products soften by heating then harden again on cooling, the reaction being reversible (contrary to thermosets). They include adhesives based on ethyl vinyl acetate (EVA) and vinyl ethylene, organic solvent-based adhesives (neoprenes, and other rubber and polyurethane elastomer-based adhesives) and water soluble adhesives (vinyls, acrylics, epoxies and polyesters).

#### ***Mastics***

These products polymerize in contact with atmospheric moisture, and include silicone and polyurethane types.



## Adhesion

### Adhesion mechanisms

Numerous theories exist concerning the mechanisms of adhesion, namely the mechanical, electronic, diffusion, thermodynamic and chemical theories. None of them alone can explain all aspects of adhesion. However, it appears that the mechanical

theory, based on keying of the adhesive to surface micro-asperities, together with the thermodynamic theory involving so-called Van der Waals bonds, are most representative of the phenomena observed in practice.

### Surface wetting

The essential condition for good bonding is satisfactory wetting of the substrate by the adhesive. The ability of an adhesive to wet a surface depends on the surface tensions of the adhesive and substrate ( $\gamma_a$  and  $\gamma_s$  respectively), and also on the interface tension between the adhesive and the substrate (fig. 3.3.1). In practice, for the adhesive to

correctly wet the surface of a substrate (i.e. to spread out over it, so that  $\theta \mapsto 0$  and  $\cos \theta \mapsto 1$ ), the surface tension of the substrate must be greater than that of the adhesive, i.e.  $\gamma_s > \gamma_a$ .

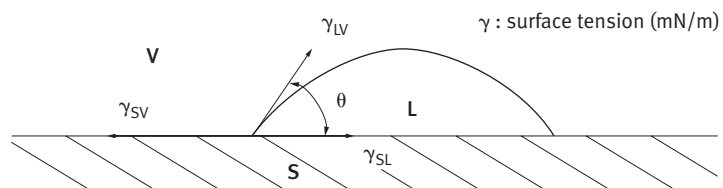

S : Substrate (solid) – V : Adhesive vapor – L : Liquid (adhesive)

$\gamma_{LV}$  : Surface tension of the liquid adhesive in equilibrium with its vapor (mN/m)

$\gamma_{SV}$  : Surface tension of the solid substrate in equilibrium with the adhesive vapor (mN/m)

$\gamma_{SL}$  : Interface tension between the liquid adhesive and the solid substrate (mN/m)

Young's model :  $\gamma_{SV} = \gamma_{SL} + \gamma_{LV} \cos \theta$

Contact angle :  $\theta < 90^\circ \rightarrow$  good wetting of the substrate by the adhesive

Fig. 3.3.1 - Wetting of a substrate by an adhesive

## Bonding procedures

### Surface preparation

In order to promote bonding, all substances liable to chemically or physically reduce wetting must be eliminated, and if possible, the surface treatment should even improve the intrinsic wettability. This is

mainly achieved by mechanical means such as sandblasting, grinding, etc., by chemical treatments such as pickling or anodizing, or by combinations, for example, sandblasting followed by application of a bonding primer.

### Application of the adhesive to the substrate

The technique to be employed depends on the physical and chemical nature of the adhesive. Available methods include ap-

plication with a roller or brush, spray coating and casting.

### Joining

The two surfaces are brought together, taking great care to avoid creating any discontinuity in the adhesive film.

### Setting or curing

The adhesive can set or harden in different ways, including at room temperature or on heating, in either case with or without

applied pressure, or due to the effect of ultraviolet radiation at ambient temperature.

## Advantages of adhesive bonding for stainless steels

As indicated in the introduction, adhesive bonding is a useful technique for joining stainless steels, since it modifies neither the microstructure nor the geometry, and what is probably even more important, does not alter the appearance. However, the strength of the joints obtained is not comparable to those produced by welding or brazing. Thus, the shear stress of an adhesively bonded joint typically varies from 1 to 30 N/mm<sup>2</sup>,

whereas for a welded joint values of about 500 N/mm<sup>2</sup> are obtained, whatever the stress direction. Because of this, adhesive bonding is always used to produce lap joints, with the load being spread over a sufficiently large area to appropriately limit the stresses. Furthermore, for reliable behaviour, the joint must be loaded only in the tensile shear mode.

## Preparation of stainless steel surfaces

The passive layer on a stainless steel is composed mainly of oxides and hydroxides of iron and chromium, but can be contaminated by various foreign elements that are

detrimental to good adhesion. It is therefore necessary to prepare the surface so as to ensure good wetting by the adhesive (cf. the section “surface wetting”).

### Mechanical surface preparation

The aim of mechanical surface treatments is to increase the roughness and enhance keying. This is obviously only effective if the adhesive satisfactorily wets the asperities produced. The techniques most commonly employed are sandblasting with abrasive silica or alumina particles projected in a pressurized fluid (dry air) or grinding with abra-

sive belts or wheels. In the latter case, the abrasive is either alumina (corundum), silicon carbide (carborundum) or zirconia (zirconium oxide). After sandblasting or grinding, the surface must be degreased with a solvent (1-1-1 trichloroethane) to eliminate all traces of abrasive residues.

### Cleaning

#### *Degreasing in hot alkali baths*

These baths remove foreign material from the stainless steel surface. Agitation is recommended for increased efficiency. After degreasing, thorough rinsing with pure water is essential.

the vapor phase, since the liquid which condenses on the metal surface is always clean. If cleaning is carried out with a cloth, it must be white, and must be changed as soon as it becomes even slightly dirty. If cleaning is performed by immersion in liquid solvent, it is essential to verify the cleanness of the bath, which must contain little or no grease. After cleaning, all residues must be removed from the surface with a detergent, followed by abundant rinsing in pure water.

#### *Solvent degreasing*

The principal solvents used are trichloroethylene and 1-1-1 trichloroethane. The best results are obtained when they are used in

### Chemical treatments

#### *Acid bath pickling*

Details of these treatments are given in the section “pickling baths” of Chapter 10. The most commonly employed compositions are mixtures of nitric and hydrofluoric acids.

#### *Pickling followed by anodizing*

After acid bath pickling, anodizing is performed in either nitric acid or a mixture of sulfuric and chromic acids.

## Laboratory results obtained with different adhesives

Tensile-shear tests have been performed in the laboratory on a number of adhesively bonded joints, in the as-bonded condition. Only cases of “cohesive failure” were considered, i.e. failure within the adhesive itself, as opposed to “adhesive failure” at the metal/adhesive interface. All the tests involved the austenitic stainless steel X5CrNi18-10/1.4301, with a 2B surface finish, with roughness values  $R_a$  varying from 0.03 to 0.2  $\mu\text{m}$ . In order to facilitate bonding of certain adhesives, an epoxy-modified acrylic bonding primer was used.

With a room temperature curing acrylic adhesive (minimum time 20 minutes), the shear strength measured for a 200  $\mu\text{m}$  thick bond layer was about 13  $\text{N}/\text{mm}^2$ , whatever the surface preparation. For a room temperature curing polyurethane adhesive (minimum time 2 hours under applied pressure

or 48 hours without pressure), the shear strength measured for a 200  $\mu\text{m}$  thick bond layer was 12  $\text{N}/\text{mm}^2$  with a bonding primer, although values of about 2  $\text{N}/\text{mm}^2$  were common with other adhesives of the same family. In the case of the epoxy-based adhesives, shear strengths of the order of 30  $\text{N}/\text{mm}^2$  are typical for 200  $\mu\text{m}$  thick joints. However, the curing time necessary at ambient temperature varies from 48 hours to several days, but can be reduced to a few tens of minutes by increasing the temperature to between 100 and 170  $^\circ\text{C}$ .

For mastics (polyurethanes and silicones), the shear strengths vary from 1 to 3  $\text{N}/\text{mm}^2$ , with curing times between 2 and 4 weeks at room temperature. These products can be used to produce bonds with thicknesses greater than 1 mm.

## The design of adhesively bonded joints

- a) In order to produce an adhesively bonded joint which will give satisfactory service performance, it is essential to design it in such a way that it is loaded only in tensile shear, or in compression, and never in the peeling or cleavage mode. The risk of peeling at the extremities can be limited by appropriate seaming.
- b) The area of the adhesively bonded joint must be calculated to sufficiently spread out the load and reduce the stresses to acceptable levels. For “high performance” adhesives, the overlap can be limited to 15 to 30 times the thickness of each of the two metal substrates.

For other adhesives, this value must be raised to about 100 times. The following empirical formula gives the length of overlap  $l$ , in mm, as a function of the substrate thickness  $t$ , the substrate yield stress  $Y$  ( $\text{N}/\text{mm}^2$ ) and the shear strength of the adhesive  $\tau$  ( $\text{N}/\text{mm}^2$ ), the latter parameter being determined from a tensile-shear test :

$$l = Y \times t / \tau$$

Thus, for 0.5 mm thick X5CrNi18-10/1.4301 stainless steel substrates ( $Y = 320 \text{ N}/\text{mm}^2$ ) bonded with an adhesive with a shear strength of 20  $\text{N}/\text{mm}^2$ ,  $l = 320 \times 0.5 / 20 = 8 \text{ mm}$ .

c) The thickness of the substrates and the bond layer must also be optimized in terms of mechanical strength in order to adapt the joint geometry to the service loads, avoiding the risk of cleavage effects. When the joint is subjected to dynamic loading, its strength must be about four times the dynamic stress

level. In the case of high strength adhesives, the thickness of the bond layer is typically of the order of 0.2 mm. In contrast, for certain flexible adhesives, particularly mastics, a thickness of 2 mm is common, and can often be a considerable advantage.

## Example applications

### Sandwich panels for curtain walling

These panels are generally composed of austenitic stainless steel facing sheets adhesively bonded to an aluminum alloy honeycomb structure. After assembly, the panels must have excellent flatness, and this is an advantage of adhesive bonding. The stainless steel sheet surfaces can be

prepared either by sandblasting or with an epoxy based primer. The adhesives employed are of the polyurethane-epoxy type and bonding is performed by either hot or cold pressing.

### Wall coverings

The outstanding properties of stainless steels with regard to ease of cleaning and sterilization make them choice materials for clean rooms. It is quite simple to bond

austenitic stainless steel panels to a thoroughly cleaned plain carbon steel support structure, using an epoxy adhesive that cures at ambient temperature.

### Decorative applications – monuments

In order to produce easy-to-clean floors, with good wear resistance and an attractive appearance, it is common practice to use *engraved* austenitic stainless steel sheet, often adhesively bonded either to wooden panels (plywood or fibreboard) or directly to a concrete slab. For this type of assembly loaded in compression, neoprene-based adhesives (i.e. elastomeric adhesives in a

solvent) can be employed, with the advantage that they can be applied and cured at room temperature.

When large monuments are built with stainless steel, generally the austenitic grade X5CrNi18-10/1.4301, two different construction techniques are employed. The first of these involves a self-supporting “skin”, generally assembled by weld-

ing, requiring pickling and passivation of the heat affected zones, followed by polishing of the whole surface to give it a uniform appearance. In the second procedure, the weight is supported by a framework of stainless steel tubes and shaped

sections, on top of which is placed a thin skin of similar grade. This skin used to be attached to the support by riveting, but nowadays it is adhesively bonded with a polyurethane adhesive that cures at ambient temperature.

### Transport equipment

In this area, the most characteristic applications are :

- Railroad car doors, composed of two austenitic stainless steel panels whose inside faces are polished before application of a bonding polymer (epoxy). After positioning of the panels, a polyurethane foam is injected and bonding is accomplished by hot pressing.
- Bus and coach bodies. In order to increase the life and reduce weight,

coach manufacturers now use a framework of stainless steel shaped sections and tubes in either the ferritic alloy X2CrNi12/1.4003 or the austenitic grade X5CrNi18-10/1.4301. The skin, which is adhesively bonded to this framework, is composed of glass fiber reinforced polyester panels. The adhesive employed is generally of the polyurethane type, joining being performed by pressing at ambient temperature.

### Medical applications

The major medical applications are :

- Hypodermic needles. The needle itself is produced from a fine austenitic stainless steel tube which is cold drawn and sized to obtain the required diameter. After cutting to length and bevelling at one end, the other end is bonded into the bore of a glass, polycarbonate or ethylene polymethacrylate component. The adhesive employed is a “medical” acrylic,

which can be cured at room temperature under ultraviolet radiation.

- Hip prostheses. The ball head is often made from vacuum remelted high molybdenum austenitic stainless steel. The implant is joined to the femur with a methyl methacrylate base cement. In direct contact with the biological fluids, both the stainless steel and the adhesive are well tolerated by the organism.



### 3.4 Mechanical joining

#### Introduction

The joining processes other than welding, brazing, soldering and adhesive bonding applicable to carbon steels can be readily transposed to stainless steel sheet. However, it is essential to ensure that none of the surfaces in contact are liable to induce corrosion due to galvanic coupling. In order to prevent this possibility, the differ-

ent parts to be assembled should preferably be made from the same stainless steel, or at least from equivalent grades.

#### Screwing and bolting

Stainless steel screws and bolts are produced in all the principal grades. The 13% Cr martensitic alloys are used when high strength is required. The 17% Cr ferritic steels must be used only for mild aggressive environments. Their corrosion resistance in chloride containing media can be enhanced by the addition of 1 to 1.5% of molybdenum. Austenitic grades (Fe-Cr-Ni alloys), and particularly those containing molybdenum, enable the majority of corrosion problems to be solved.

Screws and bolts are produced by three processes, namely machining, cold forging-extrusion, and hot stamping (die forging). In the former case, free machining grades are often employed to improve the productivity. The range of fastener components produced in stainless steels is the same as for plain carbon steels. The majority of them are hexagonal headed bolts, slotted and cross-recessed screws, self-tapping sheet screws, stud bolts, hexagonal nuts and washers. Stainless steel screws and bolts are normally delivered after passivation to ensure good corrosion resistance. Those produced from certain grades by cold forming enable high mechanical strengths to be obtained.



#### Riveting

Riveting is almost always carried out at ambient temperature, using rivets whose maxi-

mum diameter is about 5 mm. The principal stainless steel rivets are of the solid round head type, bored rivets, and blind rivets, for use when one of the two sides of the sheet is

not accessible. It is strongly recommended to design joints in such a way that the rivets are loaded in shear rather than in tension.

## Clinching

Clinching is a fairly recent joining technique, which in certain cases can be a useful substitute for riveting or spot welding (fig. 3.4.1). It can be readily applied to stainless steels due to their high ductility. Since it is a cold forming process, it causes no structural modifications or surface oxidation. Like in riveting, the sheets to be joined must overlap, and this can cause the formation of a confined space capable of initiating crevice corrosion. In order to avoid this risk, clinching is usually combined with adhesive bonding, producing a hermetically sealed joint. Moreover, the presence of the adhesive gives the joint a certain vibration damping capacity.

In practice, clinching is performed either with portable hydraulic tools or with hydraulic presses, comprising a punch and either a fixed die or a mobile (articulated) die. With a fixed die, the local clinched joint is round,

whereas it may be either round or rectangular with a mobile die.

Numerous stainless steel assemblies have been produced by clinching, mostly X6CrTi12/1.4512 automobile exhaust system components, with sheet thicknesses up to 1.5 mm, together with parts made from 1 mm thick sheet in X6Cr17/1.4016 and X5CrNi18-10/1.4301 grades. For a given sheet thickness, if the punch force required for plain carbon steel is  $F$ , then it will be  $1.5 \times F$  for X6Cr17/1.4016 ferritic stainless steel and  $2 \times F$  for the X5CrNi18-10/1.4301 austenitic alloy.

Fig. 3.4.1 - Principle of clinching

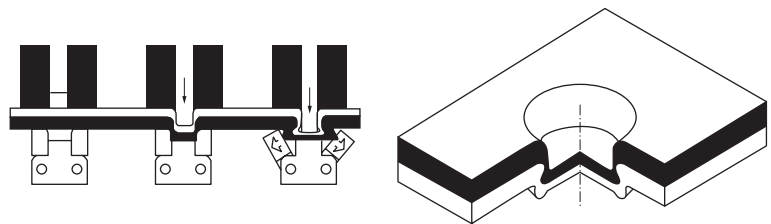

## Lockseaming

Lockseaming is a mechanical sheet joining technique in which the edges of one or both of the sheets concerned are bent through an angle of  $180^\circ$  to produce a tight seam. The operation involves folding, or more frequently, rolling with a series of appropriate tools (fig. 3.4.2). Like in clinching, it is possible to join different materials. For example, a deep drawn X5CrNi18-10/1.4301 aus-

Fig. 3.4.2 - Joining by lockseaming

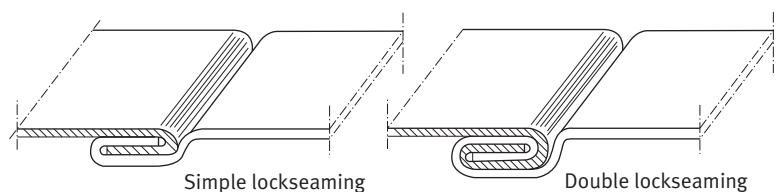



tenitic stainless steel appliance component could be joined to a relatively undeformed X6Cr17/1.4016 ferritic part whose corrosion resistance in the intended service medium is sufficient. This can allow significant cost savings if it is envisaged right from the product design stage.

Contrary to a commonly held belief, lock-seaming of stainless steels enables the pro-

duction of perfectly leaktight joints. In the event of doubt, sealing can be enhanced by the use of a seam of adhesive. Because of the rapidity of implementation and the economies it can generate, lockseaming is widely used in the manufacture of domestic appliances when the mechanical loads involved are not too high.

### Tube expansion

Tube expansion is used to rigidly and hermetically fix the end of heat exchanger tubes in the holes of the tubeplate (fig. 3.4.3). The expanding tool is composed of a conical shaft supporting a ring of rollers. The rotating shaft is pushed into the end of the tube, causing it to expand outwards. The drive torque increases with the degree of expansion, and tends towards a limit which enables the as-expanded tube thickness to be controlled via a torque limiter. The initial clearance between the outside diameter of the tube and the diameter of the tubesheet bore varies from 0.2 mm for small tubes to 0.4 mm for tubes with diameters greater than 30 mm.

Three major joint configurations are employed:

- Tube expansion in a smooth bore, which enables tube replacement.
- Tube expansion in a grooved bore, which prevents tube replacement.
- Tube expansion in a smooth bore, with flaring of the tube end.

In certain cases, the tube expansion operation is completed by welding, with a circular seam made by the orbital TIG process. However, such practice is not without risk and is generally not recommended. Joints produced by tube expansion without welding are usually perfectly leaktight up to internal pressures of the order of 50 bars and maximum temperatures of about 150 °C.

Fig. 3.4.3 - Joining by tube expansion (all lengths in mm)

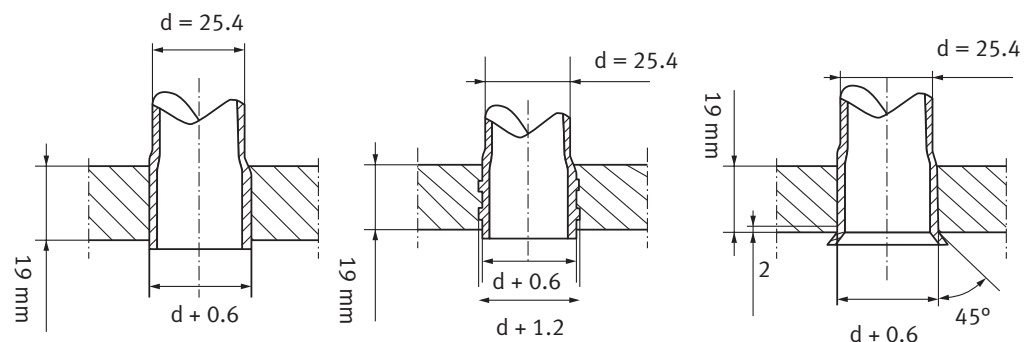

## 4. Surface condition

### 4.1 Characterisation of the surface

#### Introduction

As indicated in Chapter 5, a wide range of surface conditions are available for designers to choose as a function of the intended application. This great diversity essentially concerns flat products, i.e. sheet and strip, for which surface quality is often an important aspect. The surface appearance, and especially its stability with time, are determined by the corrosion resistance. The various industrially available surface conditions are obtained in three different ways:

- a) By on-line treatments, for example, in the case of the “annealed and pickled” and “bright annealed” conditions.
- b) By mechanical engraving in a rolling operation (also on-line), involving the transfer to the stainless steel strip of a pattern or texture from one or two rolls.
- c) By the removal of matter with abrasive belts or wheels. This type of treatment can be applied both to coiled strip and to individual sheets.



Photo 11: Milk pasteurizing plant

### Characterization of surface condition

Although surface appearance is partly subjective in nature, in order to characterize it and reproduce it industrially, it is necessary to employ “objective” techniques.

Among these, those most frequently used are roughness and reflectivity measurements.

#### Roughness

Roughness measuring instruments enable the microgeometry of the surface to be recorded in two or three dimensions. The recorded profile (fig. 4.1.1) is used to calculate the average roughness  $R_a$  and the maximum roughness  $R_t$ .  $R_a$  is the arithmetic mean of all the deviations of the profile from the mean line  $l_m$ . The maximum roughness  $R_t$  is the largest peak-

to-valley height measured in the complete assessment length (i.e. the vertical distance between the lowest and highest points).

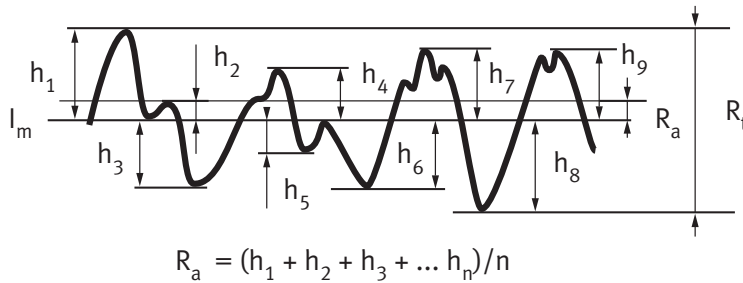

Fig. 4.1.1 - Definitions of the average roughness  $R_a$  and the maximum roughness  $R_t$

## Brightness

Brightness is evaluated by measuring the intensity of a light beam reflected by the surface to be analyzed, as a function of the intensity and angle of the incident beam (fig. 4.1.2). By way of example, Table 4.1.1 gives typical brightness values for two common surface conditions for a ferritic and an austenitic stainless steel.

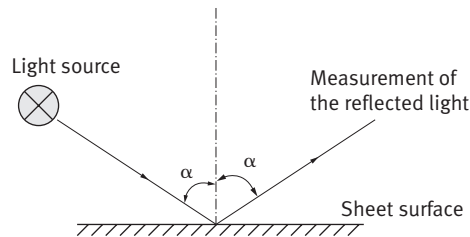

Fig. 4.1.2 - Brightness measurement

European designation EN 10088-2		Brightness (dimensionless units)	
Name	Number	2B (annealed, pickled, skinpassed)	2R (bright annealed, skinpassed)
Austenitic			
X5CrNi18-10	1.4301	20 – 30	50 – 55
Ferritic			
X6Cr17	1.4016	50 – 55	56 – 60

Table 4.1.1 - Typical brightness values for stainless steels with common surface conditions

## The principal surface conditions

The diversity of the available surface conditions is represented in Table 4.1.2, which should be analyzed in combination with Table 1.5.1 (Section 1.5), describing the manufacturing process for stainless steel flat products. The starting product is the hot rolled strip produced either in a continuous mill or a reversible Steckel mill. This strip is annealed, shot blasted and pickled to obtain what is usually considered as the hot rolled product (HR), corresponding to no. 1 finish, designated 1D, according to EN 10088-2. The HR product with its 1D finish is then subjected to a series of cold rolling operations on Sendzimir mills, generally with one or more annealing treatments. Three types of finish are distinguished for the resulting cold rolled products (CR):

- 2D finish : CR + annealed + pickled;
- 2B finish : CR + annealed + pickled + skinpassed;
- 2R finish : CR + bright annealed (in a reducing atmosphere, followed by a skin pass).

The skin pass involves rolling in a two-high mill to produce a slight elongation. Since the rolls have a mirror finish, skin pass rolling improves both the flatness and the brightness.

The strip products obtained in this way are often subsequently polished with an abrasive of appropriate grain size, in order to obtain the required surface appearance (generally either matt or bright), whose evaluation by visual examination is relatively subjective. Abrasive belt polishing is well

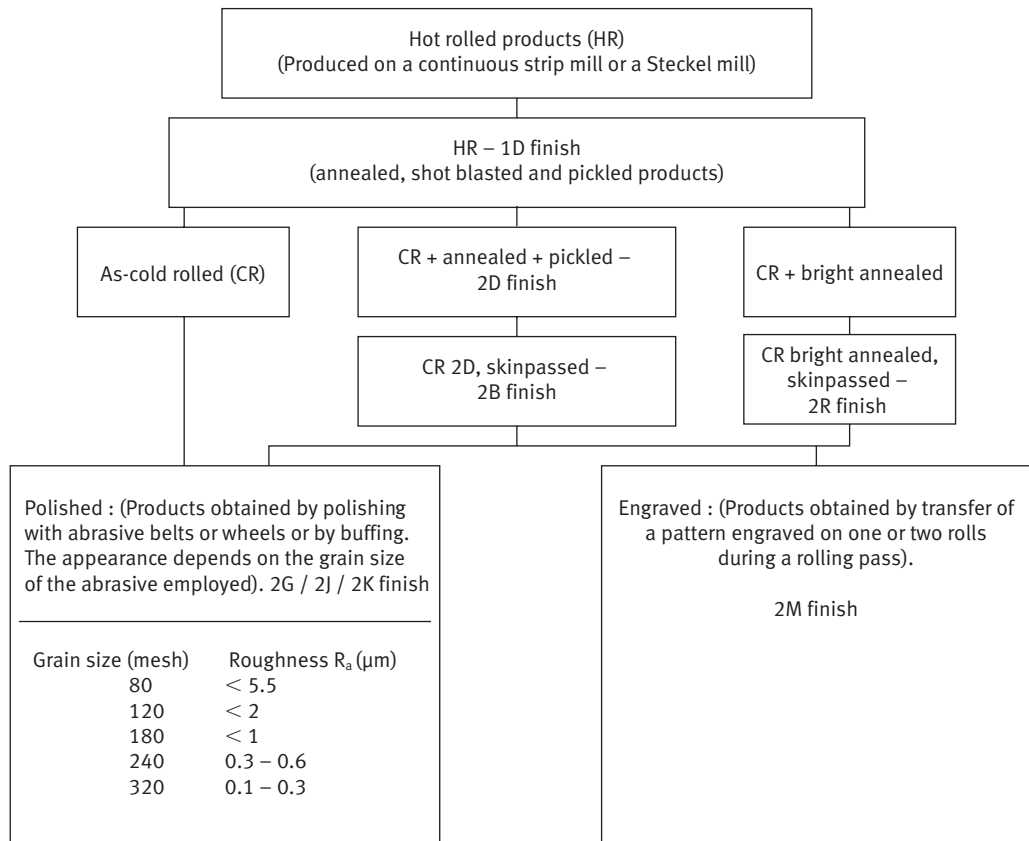

Table 4.1.2 - Principal surface finishes for stainless steel flat products

adapted to flat surfaces. In order to obtain a satin finish, brushes with natural or synthetic fiber bristles are used. Polishing with abrasive strips bonded to a wheel produces short scratches and facilitates retouching. Finally, mirror finishes are obtained by polishing with a buffing wheel, composed of a number of bonded felt disks, typically 200 to 300 mm in diameter, with tangential speeds of the order of 2000 m/min.

In addition to mechanical polishing with abrasive belts and wheels, stainless steels can be polished electrolytically.

Electropolishing is particularly suited to parts whose shape makes them impossible to polish by mechanical means. The workpiece is immersed in a bath of electrolyte and acts as the anode. The electrolyte composition can vary, depending on the process configuration, with three main types, namely phosphoric acid solutions, citric acid-sulfuric acid mixtures and glycolic acid-sulfuric acid mixtures. Depending on the type of bath, the current density varies from 8 to 65 A/dm<sup>2</sup>, the voltage from 2 to 12 V and the temperature from 60 to 90 °C.



## 4.2 Surface preparation and treatments

### Peening

Like other blasting operations, peening consists in projecting a high velocity stream of hard particles, with diameters from 0.15 to 0.6 mm, through a nozzle onto the workpiece surface. The particles employed are more or less spherical and non-abrasive. Their velocity and the duration of the operation must be optimized to obtain the desired result. A larger particle size and a higher velocity increase the roughness, whereas the latter tends to decrease with time as the operation is continued.

Peening induces a heavily cold worked surface layer, whose thickness can attain 0.3 mm. The associated compressive stresses can have a beneficial influence on fatigue strength, and peening thus provides a means of increasing the service life of finished components.

If peening cannot be followed by a decontamination treatment, the use of non-stainless iron-rich particles must be avoided. Finally, peening often constitutes an effective surface preparation before painting.



*Photo 12: Surface finishing. A variety of different finishes – such as mirror polish – can be achieved to meet technical requirements*

### Sand blasting and glass bead peening

In sand blasting, abrasive particles (silica, alumina, etc.) are projected onto the workpiece with the aid of a high pressure fluid (air or water). Glass bead peening is a simi-

lar operation in which the particles are small non-abrasive glass beads, and is particularly useful for obtaining a uniform appearance on complex shaped finished parts.

### Wheel grinding

In this process, the workpiece surface is abraded with a grinding wheel rotating at a high speed, with typical tangential velocities between 20 and 80 m/sec. The abra-

sive particles are generally either alumina (corundum) or silicon carbide (carborundum), and more rarely boron carbide or diamond. For rough grinding operations,

such as the removal of the excess thickness at a weld, 100-200 mm diameter cylindrical wheels are employed, with grain sizes of the order of 40 mesh. Depending on the type of binder, the tangential velocity varies from 25 to 60 m/sec. For finish grinding

operations (e.g. fine levelling of welds), semi-rigid or flexible abrasive disks are used, with diameters in the range 150-250 mm and grain sizes from 80 to 320 mesh, the tangential velocity being between 12 and 15 m/sec.

### Polishing<sup>1)</sup>

Polishing is the most common surface finishing operation and has already been described in the section about the principal surface conditions and Table 4.1.2. When applied to a finished part, the aim is often to restore the original appearance of a particular region, such as a weld. In other cases, for example cooking utensils or dishes, the purpose may be to give the finished article a matt or bright appearance which cannot be obtained directly after a drawing or other forming operation. In all cases, the tools employed must be strictly reserved for stainless steels, in order

to avoid all risk of contamination by iron particles.

Compared to other materials, for stainless steels, the removal of matter requires a greater amount of energy. Care must therefore be taken to avoid excessive heating, which can cause slight surface oxidation, hindering the formation of a passive film. The pressure exerted by the disk or belt must be adjusted to the minimum level allowing satisfactory abrasion without local overheating.

### Chemical treatments<sup>2)</sup>

#### Prepickling or scale conditioning

After certain high temperature operations in oxidizing atmospheres, the scale is too thick and too dense to be removed by normal acid pickling. In these conditions, three types of prepickling treatment can be applied:

- Immersion for about 15 minutes in a bath of molten caustic soda containing 5 to 20% of sodium or potassium nitrate at 450 °C.

- Immersion for about 15 minutes in a molten mixture comprising 85% of caustic soda, 14% of sodium or potassium nitrate and 1% of sodium chloride at 485 °C.
- Immersion for a few minutes in a molten mixture of caustic soda and 1 to 2% of sodium hydride at 380 °C.

Whatever the treatment employed, it must be followed by immersion and rinsing in cold water, then by acid pickling.

<sup>1)</sup> This subject is treated in greater detail in following Euro Inox publication: VAN HECKE, Benoît, *The Mechanical Finishing of Decorative Stainless Steel Surfaces* (Materials and Applications Series, Volume 6), Luxembourg: Euro Inox, 2005

<sup>2)</sup> This subject is treated in greater detail in following Euro Inox publication: CROOKES, Roger, *Pickling and Passivating Stainless Steel* (Materials and Applications Series, Volume 4), Luxembourg: Euro Inox, 2004

### Acid bath pickling

Acid bath pickling removes the oxide scale formed during high temperature operations in an oxidizing atmosphere, including welding. Pickling can be performed in several ways, but whenever possible, immersion in an acid bath is to be preferred.

For ferritic and martensitic stainless steels, the reagents employed are either mixtures of nitric and hydrofluoric acids or sulfuric acid. The typical compositions and treatment conditions are given below.

#### a) Nitric-hydrofluoric acid baths

- 62% nitric acid (40° Baumé) : 200 liters
- 65% hydrofluoric acid : 10 liters  
or sodium fluoride : 15 kg
- Water : 800 liters
- Temperature : 50–60 °C
- Duration : about  
15 minutes

#### b) Sulfuric acid baths

- 90% sulfuric acid : 100 liters
- 35% hydrochloric acid : 50 liters
- Water : 900 liters
- Temperature : 50–55 °C
- Duration : about  
15 minutes

For *austenitic stainless steels*, either nitric-hydrofluoric or sulfuric acid baths are also used, but with different compositions.

#### a) Nitric-hydrofluoric acid baths

- 62% nitric acid (40° Baumé) : 200 liters
- 65% hydrofluoric acid : 20 liters  
or sodium fluoride : 30 kg
- Water : 800 liters
- Temperature : 50–60 °C
- Duration : about  
15 minutes

#### b) Sulfuric acid baths

- 90% sulfuric acid : 100 liters
- Water : 900 liters
- Temperature : 60 °C
- Duration : a few  
minutes

### Passivation

When exposed in air, stainless steels passivate naturally, but the time required can vary greatly, depending on the type of atmosphere. In order to ensure that the passive layer reforms rapidly after pickling, a passivation treatment is therefore per-

formed in acid baths, in the following conditions.



***For ferritic and martensitic stainless steels:***

- 62% nitric acid (40° Baumé) : 500 liters
- Water : 500 liters
- Temperature : about 20 °C
- Duration : about 30 minutes

***For austenitic stainless steels:***

- 62% nitric acid (40° Baumé) : 250 liters
- Water : 750 liters
- Temperature : about 50 °C
- Duration : about 15 minutes

**Decontamination**

The decontamination treatment is similar to that used for passivation, but its purpose is different. During the various processing operations, the surface of stainless steel parts

can become contaminated by readily oxidizing iron-rich particles, whose presence can create initiation sites for corrosion. It is therefore essential to remove them, and this is the aim of the decontamination treatment.

**Finishing treatments for welds**

The finishing treatments used for welds (p. 89) are virtually identical to those

described above, and are absolutely essential to give the welds a similar corrosion resistance to that of the base metal.

**Surface maintenance\***

Stainless steels are used essentially for their good corrosion resistance, which is synonymous with long life and durability

of appearance. Nevertheless, it is essential to clean their surfaces periodically, in order to remove dirt.

**Cleaning reagents**

***General purpose products***

Most everyday cleaning products can be used for stainless steels. However, since their exact composition is generally not known, after cleaning, it is essential to abundantly rinse the surface with pure water.

riodic cleaning. Whatever the product employed, cleaning must be followed by abundant rinsing in pure water.

***Detergents and soaps***

Most domestic detergents and soaps can be used. In particular, window washing products are generally well adapted for pe-

***Abrasive powders and pads***

These products can be useful for rubbing off very adherent dirt. However, they generally modify the brightness and hence the appearance of the surface. For this reason, milder scouring creams are to be preferred. In all

\* This subject is treated in greater detail in following Euro Inox publication: *Cleaning and Maintenance of Stainless Steel Architectural Surfaces*, Luxembourg: Euro Inox, 2003

cases, the powders used must be free from iron oxides. Cleaning must always be followed by abundant rinsing with pure water. In the case of polished surfaces, rubbing must be carried out parallel to the polishing scratches.

#### *Solvents*

The use of solvents is sometimes necessary to remove highly resistant deposits. All the common solvents can generally be used, but residues should be removed by abundant rinsing in pure water.

#### *Acid-based cleaning reagents*

The use of acid-based cleaning products should be envisaged only in very specific cases (e.g. scale or fur removal), according to a well established procedure. Certain products based on phosphoric or nitric acids are specially designed for stainless steels. Conversely, products containing hydrochloric acid are strictly prohibited. All traces of acid must be eliminated by abundant rinsing in pure water.

#### *Alkali-based cleaning reagents*

Sodium and potassium hydroxide solutions are generally well adapted to stainless

steels. However, their use must be followed by abundant rinsing in pure water.

#### *Disinfectants*

Cold diluted hypochlorite can be used with great precaution. However, hot hypochlorite, even highly diluted, is strictly prohibited. Contact times between the metal and the solution must be limited to the absolute minimum. Even more so than with other products, disinfection must be followed by thorough rinsing in pure water.

#### *Protective waxes*

The best protection for a stainless steel is its passive layer. These products provide no extra protection in terms of corrosion resistance, and can often even be detrimental, since they can help to trap dirt.

#### *Compatibility with stainless steels*

All cleaning products are not identical with regard to their compatibility with stainless steels. Users must therefore check with the product suppliers whether the particular product is suitable for cleaning the type of stainless steel envisaged.

## **Cleaning methods**

### ***Building and decorative applications***

There are three different types of cleaning operations, corresponding to commissioning, routine maintenance and renovation.

#### *Cleaning on commissioning*

During storage and handling on the construction site, stainless steel products are

generally protected with a peelable adhesive plastic film, which is removed when the building is commissioned. If the surface is exposed to sunlight, the duration of exposure of this film must not exceed 6 months. Once the film has been removed, care must be taken to keep the surfaces clean,

particularly if work continues on the site. In the event of accidental soiling, cleaning must be performed with an appropriate detergent, followed by abundant rinsing with pure water.

#### *Routine maintenance cleaning*

- *Outdoor surfaces:* Maintenance cleaning is usually performed with standard chlorine-free detergents, in the form of powders, liquids or soaps. Washing should be carried out with a sponge and followed by abundant rinsing with pure water. It is recommended to wipe off the surplus liquid with a squeegee to prevent moiré effects on drying.
- *Indoor surfaces:* Routine cleaning can be carried out with the same detergents as for outdoor surfaces. However, this is not sufficient to remove fingermarks, which

require acid-containing products with the addition of a degreasing agent. For very resistant stains, it may be necessary to use abrasive scouring pads, made from stainless steel wool, nylon, or similar materials. Rubbing must be performed in the direction of initial polishing. The use of ordinary steel wool is strictly prohibited. Great care must also be taken to avoid splashing with chlorine-containing detergents used for cleaning floors (e.g. hypochlorite solutions and other disinfectants). Should this occur, the affected surfaces must be immediately rinsed abundantly with pure water.

#### *Cleaning for renovation*

If routine cleaning has been long neglected, or if the stainless steel shows traces of corrosion, a specific treatment is necessary after having made a precise diagnosis.

### **Food processing equipment**

Cleaning must be adapted to the type of product in contact with the stainless steel equipment. It is almost always followed by a disinfection treatment, and then by abundant rinsing with pure water. Certain disinfectants are aggressive towards stainless steels, so that strict procedures must be applied. The latter must be approved by the supplier, who must guarantee the compat-

ibility of his product with the type of stainless steel concerned. If incipient corrosion is observed, the manufacturer of the cleaning product or disinfectant must be immediately consulted, together with the stainless steel supplier, in order to carry out an appropriate treatment according to their recommendations.

#### *Collective catering equipment and domestic appliances*

Collective catering equipment and domestic appliances are usually cleaned on a daily basis. When properly performed, such cleaning is a warranty of long life for the stainless steel. The products used are those described

in the section “cleaning reagents”, while the precautions to be taken are those indicated in the section “cleaning methods”.

## 5. Testing and inspection

### 5.1 Metallurgical testing and inspection

#### Introduction

Only metallurgical and mechanical testing and inspection will be considered in the present part, since the dimensional inspection techniques employed for stainless steels are not basically different to those used for plain carbon steels.

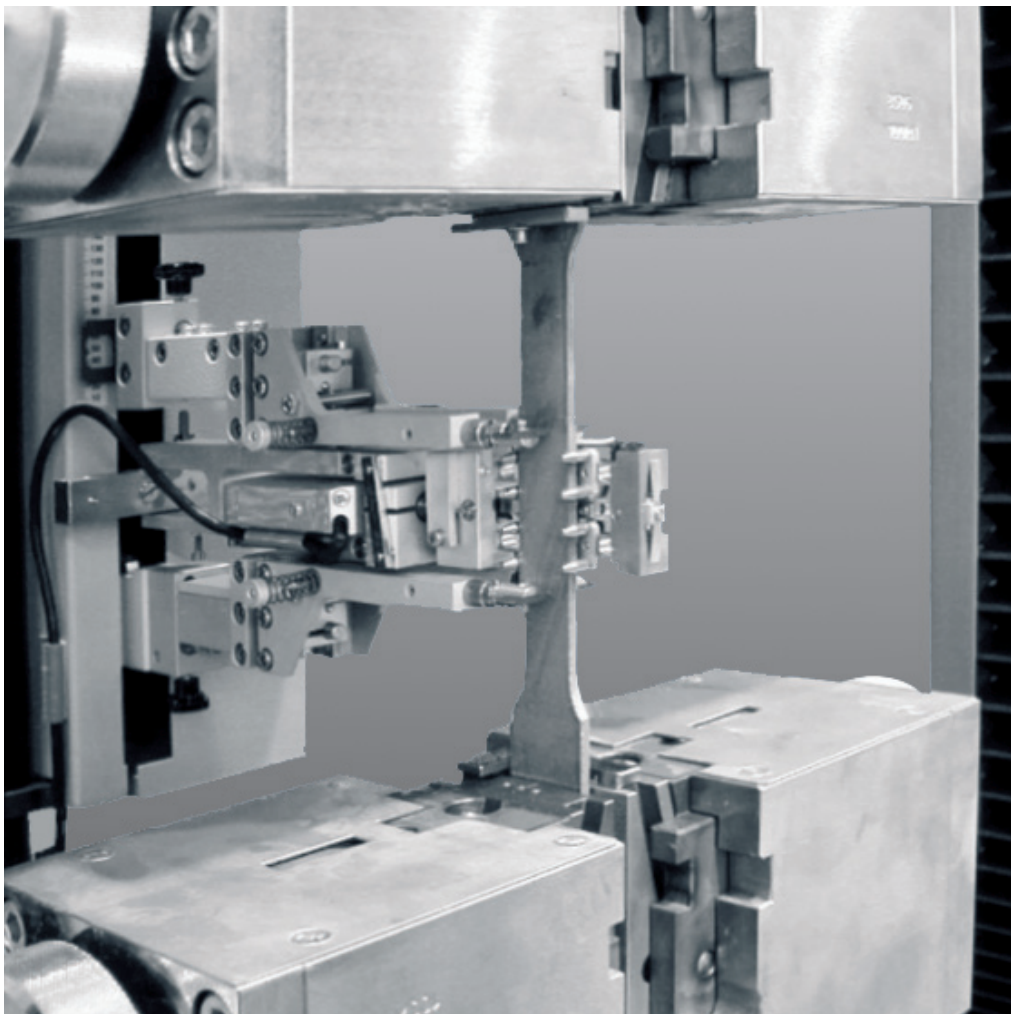

*Photo 13:  
Tensile-testing:  
In tension test, a specimen is deformed by constant but smooth load until it breaks. During the test, the stress to produce given elongation (or strain) is measured as dependent variable, and based on the measured values a stress-elongation (or strain) curve is plotted.*

## Metallurgical testing and inspection

In order to characterize an alloy in metallurgical terms, it is necessary to determine its chemical composition and its microstruc-

ture, and this is the purpose of metallurgical testing and inspection.

### Chemical analysis

Although the term “chemical analysis” is widely employed to indicate the determination of the elemental composition or “chemistry” of an alloy, in fact, increasing use is made today of physical techniques, such as X-ray fluorescence spectrometry, glow discharge optical spectrometry, opti-

cal emission spectrometry, etc., particularly for the major alloying elements (Cr, Ni, Mn, Si, etc.). For certain elements, such as carbon, sulfur and nitrogen, specific methods are employed, involving the analysis of the combustion products based on their effects on the absorption of infrared radiation.

### Metallographic examination

A distinction is generally made between macrographic examination at low magnifications (up to  $\times 50$ ) and micrographic examinations at higher magnifications ( $\times 100$

to  $\times 1200$ ). The etching reagents used to reveal the micro-structure are adapted to each family of stainless steels.

### *Austenitic stainless steels*

In order to reveal the general microstructure, Vilella’s reagent is employed. This is a mixture of aqua regia and glycerine, with the approximate composition: 2 volumes of

hydrochloric acid, 1 volume of nitric acid and 3 volumes of glycerine. The immersion time is of the order of 30 seconds.

### ***Ferritic stainless steels***

One of the most frequently used etchants is Vilella's reagent, whose composition is: 5 ml of hydrochloric acid, 1 g of picric acid and 95 ml of ethyl alcohol. There is also a modified version particularly adapted

to 12% Cr grades, whose composition is 20 ml of hydrochloric acid, 12 ml of acetic acid, 1 g of picric acid and 68 ml of ethyl alcohol.

### ***Duplex austenitic – ferritic stainless steels***

One of the most commonly employed techniques for revealing the micro-structure of duplex austenitic – ferritic stainless steels is electrolytic etching for 10 to 30 seconds

in an 85% volume nitric acid-15% volume water solution, with the specimen as the anode and the voltage adjusted to give a current density of 50 mA/cm<sup>2</sup>.

## 5.2 Mechanical testing



Photo 14: Steam pressure cooker

### Introduction

Like for other metals and metallic alloys, the mechanical characteristics are determined by the elasticity, plasticity and toughness properties. Elasticity is the faculty of a material to deform reversibly when subjected to a stress and to return to the initial state when the stress is removed. Plasticity or ductility is the aptitude to undergo permanent deformation under load without fracture. This property is frequently exploited, for example in forming operations such as bending and drawing. Toughness is a measure of the energy necessary for fracture and implicitly involves the tendencies for either brittle cleavage or ductile tearing, together with the transition temperature at which the fracture mode changes from one to the other. It is usually determined in an impact bending

test on a notched specimen, by measuring the energy necessary for fracture at a given temperature.

The machines used for the mechanical testing of stainless steels are identical to those employed for ordinary steels and other metals and alloys.

## Tension tests

### Description of the test

In a tension test, a calibrated specimen is forced to elongate, generally at a constant imposed rate, requiring an increasing load, due to the reaction of the material. The test piece comprises two markers, separated by an initial distance  $l_0$  (often 80 mm). If a force  $F$  is applied to the calibrated gage length of initial area  $A_0$ , the resulting elongation increases the distance between the markers from  $l_0$  to  $l$ . The corresponding nominal or engineering strain, expressed in %, is then given

by  $e = 100(l - l_0)/l_0$ , while the nominal or engineering stress is  $F/A_0$ , and is expressed in N/mm<sup>2</sup> or MPa. The plot of  $F/A_0$  as a function of  $e$  is called the nominal or engineering stress-strain curve, and comprises three distinct zones (fig. 5.2.1).

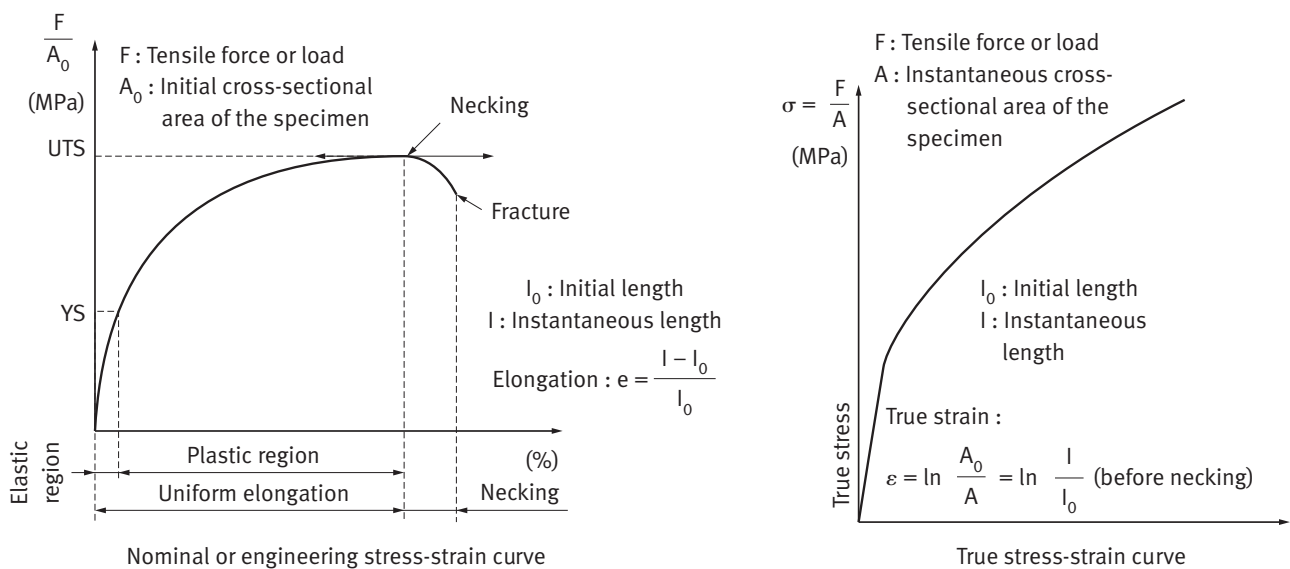

Fig. 5.2.1 - Stress-strain curves.



- a) The elastic region, in which the elongation  $e$  is proportional to the applied stress  $F/A_0$ . Theoretically, when the stress is removed, the elongation disappears completely. The upper limit of this linear elastic region is called the yield point, with a corresponding yield stress or yield strength,  $YS$ . Since it is not always easy to determine, it is often measured at a finite amount of plastic strain, e.g. 0.2%, and is known as the “proof stress” (in this case the 0.2% proof stress, designated 0.2%  $PS$  or 0.2%  $YS$ ). It is measured in  $N/mm^2$  (MPa).
- b) The uniform plastic strain region, in which the metal continues to deform uniformly, but the stress rises less rapidly with strain and no longer in a linear manner. Furthermore, when the stress is removed, the specimen no longer returns to its initial length, but remains permanently deformed. This region occurs between the yield stress  $YS$  and the maximum stress, known as the ultimate tensile stress or strength,  $UTS$ , which is also expressed in  $N/mm^2$  (MPa).
- c) Beyond the  $UTS$ , the deformation becomes locally concentrated, leading to a

constriction or “neck”, so that the stress determined in terms of the initial area falls until the specimen finally fails.

The values determined from the engineering stress-strain curve described above are those which are used in the majority of standards and specifications. However, a more correct way to analyze the results of a tension test is to employ the true stress and true strain. The true stress  $\sigma$  is the applied load at any moment divided by the instantaneous area  $A$ , i.e.  $\sigma = F/A$ . The true strain  $\epsilon$  is obtained by integrating the nominal strain increments  $dl$  from  $l_0$  to  $l$ , and is given by  $\epsilon = \ln(A_0/A)$  ( $= \ln(l/l_0)$  before necking). It is related to the nominal or engineering strain  $e$  by  $\epsilon = \ln(1+e)$ . The plot of  $\sigma$  against  $\epsilon$  is the true stress-strain curve (fig. 5.2.2), which can be used to determine the strain hardening exponent  $n$ .

Figure 5.2.2 compares the engineering and true stress-strain curves for the austenitic stainless steel X5CrNi18-10/1.4301, often used for deep drawing applications. After the onset of necking, the true stress plotted is that at the neck root, which continues to rise up to fracture.

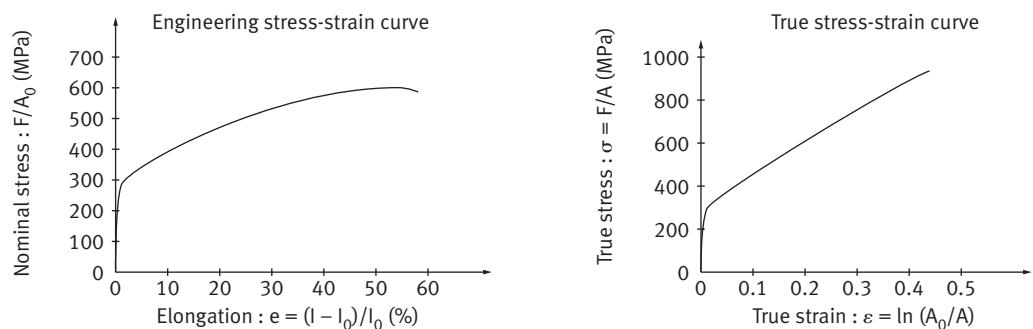

Fig. 5.2.2 - Engineering and true tensile stress-strain curves for X5CrNi18-10 austenitic stainless steel

## Characteristic values for stainless steels

The different families of stainless steels (martensitic, ferritic, austenitic, duplex) show characteristic behaviours in tension tests, the differences being directly related to their corresponding microstructures.

**Martensitic** stainless steels in the quenched and tempered condition have very high *YS* and *UTS* levels, with correspondingly low elongations to failure *El* (%). In the as-quenched condition, the *YS* and *UTS* levels are even higher and the elongation lower. However, it is generally recognized that the tensile properties have little practical meaning in the as-quenched condition, which is better characterized by the microstructure and hardness.

**Ferritic** stainless steels have stress-strain curves fairly similar to those of plain carbon grades. In particular, they have a marked yield point drop, beyond which the load rises again. The corresponding upper and lower yield points are clearly visible on the recorded load-elongation curve. The *UTS* is typically about 550 N/mm<sup>2</sup>, and is associated with elongations to failure of the order of 30%.

**Austenitic** stainless steels have stress-strain curves similar to that shown schematically in figure 5.2.2. Contrary to the ferritic

grades, the yield point is not clearly visible, and for this reason it is usual to measure the 0.2% proof stress, as described above. The *UTS* is generally of the order of 600 N/mm<sup>2</sup>, while the elongation to failure can exceed 60%. This feature, associated with a high strain hardening rate (directly related to the strain hardening exponent *n*), makes these materials particularly suited for deep drawing. Furthermore, their capacity for energy absorption is among the highest of common materials.

**Duplex austenitic - ferritic** stainless steels have high *YS* and *UTS* values, due to their fine two phase structures (50% ferrite and 50% austenite), while their elongations to failure are intermediate between those of austenitic and ferritic grades. Typical values are 800 N/mm<sup>2</sup> for the *UTS* and about 35% for the elongation.

Table 5.2.1 summarizes the typical mechanical properties of the different stainless steels in various conditions.

Alloy type	UTS (N/mm <sup>2</sup> )	0,2% YS (N/mm <sup>2</sup> )	El (%)
Martensitic (1)	500 – 850	270 – 500	14 – 30
Martensitic (2)	1200 – 2000	1000 – 1600	2 – 10
Ferritic (3)	400 – 550	250 – 380	20 – 35
Austenitic (4)	570 – 730	215 – 360	40 – 65
Duplex (4) austenitic-ferritic	800 – 900	620 – 750	25 – 35

Table 5.2.1 - Typical mechanical properties of the different stainless steels in various conditions

- (1) Tempered,
- (2) As-quenched,
- (3) Annealed,
- (4) Solution annealed and rapidly cooled.

## Hardness tests

### Test types

Hardness testing consists in pressing an indenter into the flat specimen surface under a perfectly controlled load, then measuring the dimensions of the resulting in-

Fig. 5.2.3 - Principle of Rockwell hardness tests

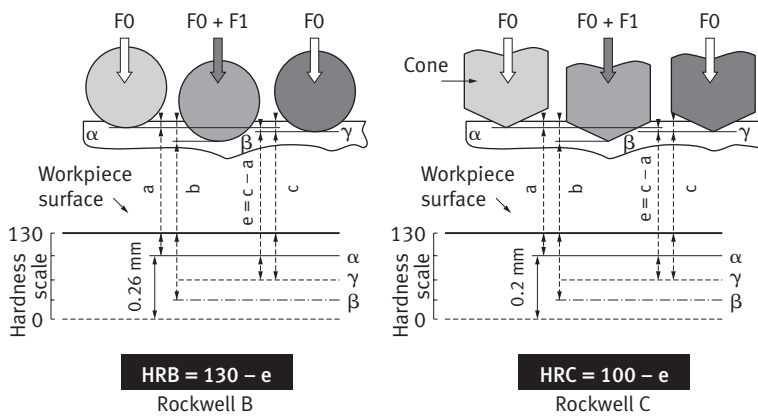

A minor load  $F_0$  is first of all applied, to break through roughness and eliminate backlash, then a major load  $F_1$  is applied, then removed. The difference in penetration depth  $e$  after removal of  $F_1$  gives the hardness. Note that one hardness unit corresponds to 0.002 mm. Here,  $a$ ,  $b$ ,  $c$ , and  $e$  are expressed in hardness units, and  $\alpha$ ,  $\beta$  and  $\gamma$  in mm.

Fig. 5.2.4 - The Vickers hardness test

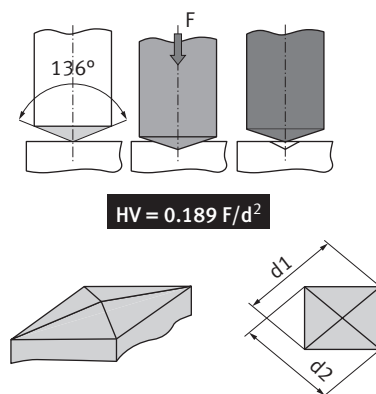

Indenter apex angle =  $136^\circ$   
 $F$  = Test load in newtons to  $\pm 1\%$   
 $d$  = Indentation diagonal in mm =  $(d_1 + d_2)/2$

dentation. Various types of indenter are used in the different hardness tests. Thus, the Brinell and Rockwell B tests use a ball indenter, while the Rockwell C and Vickers tests use a pointed conical indenter. The three methods most commonly used for stainless steels are the Rockwell B, Rockwell C and Vickers tests, the corresponding hardness numbers being designated by HRB, HRC and HV respectively.

In the Rockwell B test (fig. 5.2.3), a 1/16 inch (1.59 mm) diameter steel ball is pressed into the workpiece under a load of 100 kg and the depth of the indentation is measured. The Rockwell B scale is limited to 100 HRB, beyond which the Rockwell C test is employed.

The Rockwell C test (fig. 5.2.3) is performed on the same equipment as the Rockwell B test, but with a conical diamond indenter, under a load of 150 kg, again with measurement of the depth of indentation.

The Vickers test (fig. 5.2.4) uses a diamond indenter with a square-based pyramid shape. The load can be chosen between 5 and 100 kg, a value of 5 kg being usually employed for stainless steel sheets. The hardness is determined by measuring the two diagonals of the indentation.

### Characteristic hardness values for stainless steels

Table 5.2.2 gives characteristic hardness values for the different types of stainless steel. Because of their two phase structure, generally consisting of roughly 50% each of austenite and ferrite, greater scatter is naturally obtained for the duplex grades.

Alloy type	Condition	HRB	HRC	HV
Ferritics	Annealed	73 – 85		140 – 180
	Cold worked	90 – 100	13 – 25	180 – 290
Stabilised 11 % Cr ferritics	Annealed	67 – 83		120 – 170
Stabilised 17% Cr ferritics	Annealed	70 – 83		130 – 170
Austenitics	Solution annealed	74 – 88		130 – 185
	Cold worked		25 – 50	200 – 250
Duplex austenitic-ferritic	Solution annealed	90 – 105		
Martensitics	Softened	80 – 90		160 – 190
	Quenched and tempered		45 – 53	

Table 5.2.2 - Typical hardness ranges for the principal types of stainless steel

### Impact testing

Impact testing is used to measure the toughness of a material, corresponding to the energy necessary to cause fracture under shock loading. Low toughness is generally associated with brittle shear fracture and high toughness with ductile plastic tearing. For materials prone to brittle frac-

ture, this phenomenon is promoted by the high strain rate and the use of a notched test-piece. The major experimental parameters which influence the toughness are the temperature, the notch geometry and the strain rate.

### Test principle

The apparatus used for stainless steels, together with the specimen and notch geometries, are the same as for plain carbon steels. The most commonly employed technique is the Charpy test (fig. 5.2.5), in which the

10 x 10 mm section specimen, with a central V-notch, is struck by a freely falling pendulum. The ends of the specimen are supported from below and on the front side, with the notch vertical and facing forward, opposite

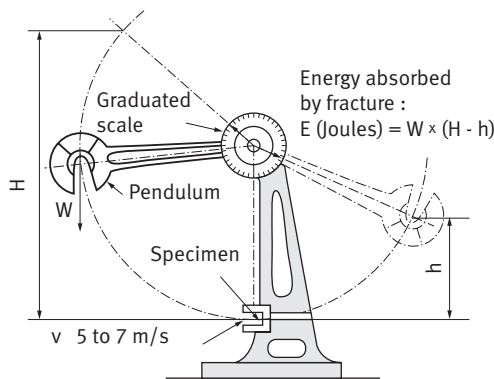

Schematic principle of the Charpy impact test

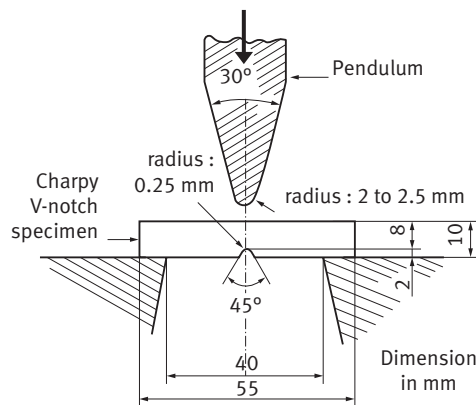

Detail of the pendulum and the Charpy V-notch specimen

Fig. 5.2.5 - The Charpy impact bending test

to the point of impact. The knife edge breaks the specimen and the pendulum rises to a height determined by the energy absorbed in fracture,  $E$ . Accurate measurement of the height of rise enables  $E$  to be calculated (in joules), and the impact strength  $K$ , in joules/cm<sup>2</sup>, is then given by  $K = E/A$ , where  $A$  is the cross sectional area at the notch root, expressed in cm<sup>2</sup>. Fracture can be either brittle or ductile. Brittle fracture involves decohesion or

cleavage, with no significant plastic strain. In this case, there is no lateral expansion of the specimen and the fracture surface is bright, with shiny facets. Ductile fracture is preceded by heavy plastic strain, accompanied by lateral expansion of the specimen, while the fracture surface has a mat, fibrous appearance. Certain materials show brittle behaviour, associated with low toughness (impact strength) at low temperatures, and high toughness ductile behaviour at high temperatures. Mixed behaviour is observed in the transition region between these two zones, which is characterized by the ductile-brittle transition temperature (fig. 5.2.6).

Fig. 5.2.6 - Effect of temperature in the Charpy V-notch impact strength. For the austenitic steel, temperature has relatively little effect, whereas for the ferritic grade a sharp transition is observed between ductile fracture (1) at high temperatures and brittle fracture (2) at low temperatures

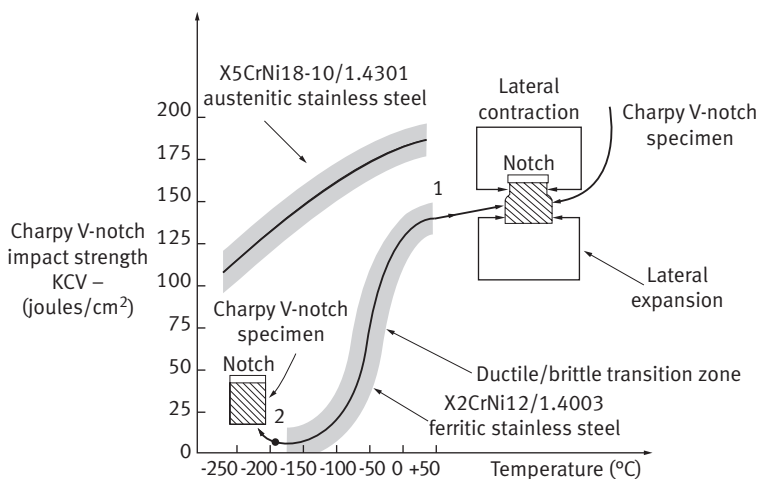

Table 5.2.3 - Typical impact strengths of different stainless steels at cryogenic temperatures

Alloy type	Temperature (°C)	KCV impact strength (J/cm <sup>2</sup> )
Martensitic (X12Cr13/1.4006)	-40	35
	-60	30
	-196	8
Ferritic (X6Cr17/1.4016)	-40	15
	-60	10
	-196	3
Austenitic (X5CrNi18-10/1.4301)	-40	170
	-60	160
	-196	130
	-250	110

### Behaviour of stainless steels and typical toughness values

The various types of stainless steels show quite different impact strengths, depending on their compositions and whether the microstructure is martensitic, ferritic, austenitic or duplex (Table 5.2.3). In the case of welds, different behaviours can be observed between the base metal, the heat affected zone and the fusion zone. In ferritic grades, an increase in chromium content raises the transition temperature, typically by about 50°C for an additional 4% of chromium. In contrast, brittle cleavage fracture does not generally occur in austenitic grades, such as X5CrNi18-10/1.4301, which consequently conserve a relatively constant impact strength, whatever the temperature. By way of example, Table 5.2.3 gives typical Charpy V-notch impact strength values for cryogenic temperatures between -40 and -250 °C.

# Appendices

## Physical and chemical properties of stainless steels

### Why five families?

Stainless steels are iron alloys containing a minimum of approximately 11% chromium which is the key alloying element. Chromium in excess of 11% forms a tenacious protective film on any exposed surface; i.e. a corrosion barrier. To effectively prevent corrosion chromium must be in solid solution form and not combined as chromium carbides.

#### Martensitic stainless steels

Martensitic stainless steels have the highest carbon content (up to 1.2%). Their mechanical strength can be increased by quenching. The martensitic structure obtained is magnetic.

#### Ferritic stainless steels

Ferritic stainless steels have a low carbon content ( $\leq 0.08\%$ ). For this reason, they do not display significant hardening after quenching. The ferritic structure is magnetic.

In the ferritic grades the toughness of the HAZ may be poor, due to grain growth during welding.

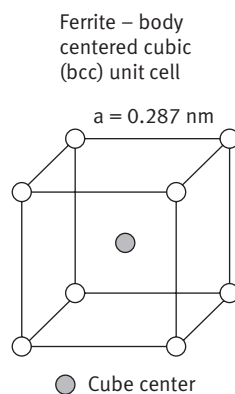
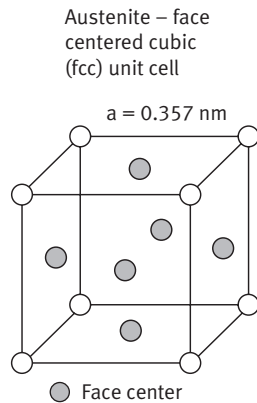

Photo 15: Professional kitchen knife. The blade is made of martensitic stainless steel.



### Austenitic stainless steels

These alloys are the most popular grades of stainless steels because of their excellent formability and corrosion resistance. Due to the presence of austenite – stabilizing alloying additions, particularly nickel, these stainless steels have the face-centered cubic austenitic structure. They are not hardenable by heat treatment, but can be strain-hardened by cold-work.

### Heat-resisting stainless steels

These iron – chromium – nickel grades have high strength at elevated temperatures and resistance to carburizing atmospheres. The basic chromium content is increased to 20-25% Cr and the nickel varies from 10-35%. All grades optimized for high temperature applications have high carbon contents.



Photo 16: Pump casing: the high ductility of austenitic stainless steels makes them suitable for one-piece designs combining deepdrawing and hydroforming techniques.

Photo 17: Duplex stainless steel bulkhead panels for chemical tankers



### Duplex austenitic-ferritic stainless steels

The microstructures of duplex stainless steels consist of a mixture of austenite and ferrite. They exhibit characteristics of both phases with higher strength and ductility. Compared with austenite grades, duplex stainless steels show higher strength and markedly better corrosion resistance in chloride solutions.



## Oxidation and oxides

Stainless steels exhibit excellent resistance to oxidizing environments. The one element essential in forming a high-temperature corrosion-resistant layer is chromium (so-called passive layer). The resulting compound is a crystalline oxide or hydroxide.

Oxidation is a process in which the proportion of the electronegative constituent in a compound is increased. In oxidation electrons are removed from the oxidized species.

An oxide is a compound of oxygen with another element. Oxides are divided into *acidic oxides* which react with bases to form salts; *basic oxides* which react with acids to form salts; *amphoteric oxides* which exhibit both basic and acidic properties.

In aqueous systems, an acid is defined as a substance which is capable of forming hydrogen ions when dissolved in water. Most inorganic acids may be regarded as a compound of an *acidic oxide* and water. When the oxide concerned is that of a metal, it may exhibit *amphoteric properties*, sometimes acting as an *acid* and sometimes as a *base*.



Photo 18: Burner part made of heat-resisting ferritic stainless steel

## Typical physical properties (according to EN 10088-1)

Physical Properties		Families of Stainless Steel	Martensitic Grades	Ferritic Grades	Austenitic Grades	Austenitic-ferritic Grades
(kg/dm <sup>3</sup> )	Density		7.7	7.7	7.9	7.8
(GPa)	Modulus of Elasticity at 20 °C:		215 000	220 000	200 000	200 000
(10 <sup>-6</sup> × K <sup>-1</sup> )	Coefficient of Thermal Expansion between 20 °C and 200 °C:		10.5	10	16	13.0
(W/(m × K))	Thermal conductivity at 20 °C:		30	25	15	15
(J/(kg × K))	Specific Heat Capacity at 20 °C:		460	460	500	500
(v × mm <sup>2</sup> /m)	Electrical Resistivity at 20 °C:		0.55	0.60	0.73	0.80



## Identification and Designation of Stainless Steels

### European Designations

#### European Specifications which are used throughout the European Union

The European Standards were given the status of a national standard, either by publication of an identical text, or by endorsement, in October 1995, and conflicting national standards were withdrawn in October 1995.

According to the CEN/CENELEC Internal Regulations, the following countries are bound to implement this European Standard:

Austria, Belgium, Cyprus, Czech Republic, Denmark, Estonia, Finland, France, Germany, Greece, Hungary, Iceland, Ireland, Italy, Latvia, Lithuania, Luxembourg, Malta, Netherlands, Norway, Poland, Portugal, Slovakia, Slovenia, Spain, Sweden, Switzerland and United Kingdom.

#### Principal standards concerning stainless steels

##### *Designation standards*

EN 10027-1 Designation for steels – Part 1: Steel names, principal symbols

EN 10027-2 Designation for steels – Part 2: Numerical system

##### *General purposes product standards*

EN 10088-1 Stainless Steels – Part 1: List of stainless steels

EN 10088-2 Stainless Steels – Part 2: Technical delivery conditions for sheet/plate and strip for general purposes

EN 10088-3 Stainless Steels – Part 3: Technical delivery conditions for semi-finished products, bars, rods and sections for general purposes

prEN 10088-4 Stainless Steels – Part 4: Technical delivery conditions for sheet/plate and strip of corrosion for construction purposes

prEN 10088-5 Stainless Steels – Part 5: Technical delivery conditions for bars, rods, wire, sections and bright products of corrosion resisting steels for construction purposes

EN 10095- Heat-resisting steels and alloys

##### *Pressure purposes product standards*

EN 10028-7 Flat products made of steel for pressure purposes – Part 7: Stainless steels

EN 10272 Rolled bars made of stainless steel for pressure purposes

EN 10216-5 Seamless steel tubes for pressure purposes – Part 5: Technical delivery conditions-Stainless steel tubes

EN 10217-7 Welded steel tubes for pressure purposes – Part 7: Technical delivery conditions-Stainless steel tubes

EN 10222-5 Steel forgings for pressure purposes – Part 5: Martensitic, austenitic and austenitic-ferritic stainless steels

##### *General purposes tube and fittings standards*

EN 10296-2 Welded circular steel tubes for mechanical and general engineering purposes – Part 2: Technical delivery conditions-Stainless steel tubes

EN 10297-2 Seamless circular steel tubes for mechanical and general engineering purposes – Part 2: Technical delivery conditions-Stainless steel tubes

EN 10312 Welded stainless steel tubes and fittings for the conveyance of aqueous

liquids including water for human consumption: Technical delivery conditions

EN 12502-4 Protection of metallic materials against corrosion – Corrosion likelihood in water conveying systems – Part 4: Review of the influencing factors for stainless steels  
*Dimensional standards*

ISO 9445 Continuously cold-rolled stainless steel narrow strip, wide strip, plate/sheet and cut lengths – Tolerances on dimensions and form (officially replaced EN 12058 and EN 12059 standards)

*Welding consumables standards*

EN 439 Welding consumables: Shielding gases for arc welding and cutting – Classification

EN 760 Welding consumables: Fluxes for submerged arc welding – Classification

EN 1600 Welding consumables: Covered electrodes for manual arc welding of stainless and heat-resisting steels-Classification

EN 12072 Welding consumables: Wire electrodes, wires and rods for arc welding of stainless and heat-resisting steels – Classification

ISO 17633 Welding consumables: Tubular cored electrodes and rods for gas shielded and non-gas shielded metal arc welding of stainless and heat-resisting steels – Classification (officially replaced EN 12073 standard)

## Standard Designation of Stainless Steels

The steel names and steel numbers were established in accordance with EN 10027. The European standard for stainless steels is EN 10088 and the designation systems adopted in this standard are the EUROPEAN MATERIAL NUMBER and the MATERIAL NAME.

The material number comprises three parts, for example 1.4301, where: 1 denotes steel 43 denotes one group of stainless steels

(austenitic grades without Mo, Nb or Ti) and 01 is the individual grade identification.

The material name system provides some indication of the alloy composition, for example X5CrNi18-10, where: X denotes high alloy steel, 5: 100x % of carbon, Cr Ni: chemical symbols of main alloying elements, 18-10: % of main alloying elements.

### Examples

- X20Cr13 / 1.4021

*Steel with a carbon content of  $20/100 = 0.2\%$  and a chromium content of 13%.*

- X2CrTi12 / 1.4512

*Steel with a carbon content of  $2/100 = 0.02\%$  and a chromium content of 12% and with a titanium addition.*

- X2CrNiMo17-12-2 / 1.4404

*Steel with a carbon content of  $2/100 = 0.02\%$  and a chromium content*

*of 17%, a nickel content of 12%, and a molybdenum content of 2%.*

- X2CrNiMoN22-5-3 / 1.4462

*Steel with a carbon content of  $2/100 = 0.02\%$  and a chromium content of 22 %, a nickel content of 5%, a molybdenum content of 3%, and a nitrogen addition.*

## Equivalence between European Number and Name Designations and AISI Designations\*

EN Number	European Designation	AISI or commercial designation
1.4000	X6Cr13	410S
1.4002	X6CrAl13	405
1.4003	X2CrNi12	403
1.4016	X6Cr17	430
1.4028	X30Cr13	420
1.4029	X29CrS13	420F
1.4057	X17CrNi16-22	431
1.4105	X6CrMoS17	430F
1.4113	X6CrMo17-1	434
1.4125	X105CrMo17	440C
1.4301	X5CrNi18-10	304
1.4303	X4CrNi18-12	305
1.4305	X8CrNiS18-9	303
1.4306	X2CrNi19-11	304L
1.4307	X2CrNi18-9	304L
1.4310	X9CrNi18-8	301
1.4311	X2CrNiN18-10	304LN
1.4335	X1CrNi25-21	310 S
1.4361	X1CrNiSi18-15-4	18.15
1.4362	X2CrNiN23-4	SAE2304
1.4372	X12CrMnNiN17-7-5	201
1.4373	X12CrMnNiN18-9-5	202
1.4401	X4CrNiMo17-12-2	316
1.4404	X2CrNiMo17-12-2	316L
1.4406	X2CrNiMoN17-11-2	316LN
1.4410	X2CrNiMoN25-7-4	2507
1.4434	X2CrNiMoN17-12-3	317LN
1.4438	X2CrNiMo18-15-4	317L
1.4439	X2CrNiMoN17-13-5	317L4
1.4460	X3CrNiMoN27-5-2	7Mo plus
1.4462	X2CrNiMoN22-5-3	2205
1.4466	X1CrNiMoN25-22-2	310MoLN
1.4501	X2CrNiMoCuWN25-7-4	Zeron 100
1.4507	X2CrNiMoCuN25-6-3	Ferralium 255
1.4509	X2CrTiNb18	441
1.4510	X3CrTi17	430Ti, 439
1.4511	X3CrNb17	430Nb
1.4512	X2CrTi12	409
1.4516	X6CrNiTi12	414
1.4521	X2CrMoTi18-2	444
1.4532	X8CrNiMoAl15-7-2	PH 15.7Mo
1.4537	X1CrNiMoCuN25-25-5	URSB8
1.4539	X1NiCrMoCu25-20-5	904L
1.4541	X6CrNiTi18-10	321
1.4542	X5CrNiCuNb16-4	630 17.4 (PH)
1.4550	X6CrNiNb18-10	347
1.4567	X3CrNiCu18-9-4	XM 7/18.9LW
1.4568	X7CrNiAl17-7	17.7PH
1.4571	X6CrNiMoTi17-12-2	316Ti
1.4580	X6CrNiMoNb17-12-2	316Cb

\* Detailed information about the chemical, mechanical and physical properties of stainless steels is available from [www.euro-inox.org/technical\\_tables](http://www.euro-inox.org/technical_tables) (an interactive database) or from the printed brochure *Tables of Technical Properties* (Materials and Applications Series, Volume 5), Luxembourg: Euro Inox, 2005

## Acronyms and abbreviations

°C	: Celsius degree	J	: Joule (energy) - (metric unit)
AISI	: American Iron and Steel Institute	K	: Crack tip stress field intensity factor (fracture mechanics)
AOD	: Argon-Oxygen Decarburization (melting process)	kg	: Kilogram
ASTM	: American Society for Testing and Materials	KCV	: Charpy impact energy absorption (toughness)
A-TIG	: Activating flux TIG (welding)	LBW	: Laser Beam Welding (welding)
AWS	: American Welding Society	LCC	: Life Cycle Costing (global costing)
CERMET	: CERamic – METal (machining)	LDR	: Limiting Drawing Ratio (drawing)
CR	: Cold Rolled (rolling)	MF	: Medium Frequency (welding, brazing)
CVD	: Chemical Vapor Deposition (machining)	MIG	: Metal Inert Gas (welding)
EL	: Elongation (%)	N	: Newton (force)
EVA	: Ethyl Vinyl Acetate (bonding)	PAW	: Plasma Arc Welding (welding)
FCAW	: Flux Cored Arc Welding (welding)	PVD	: Physical Vapor Deposition (machining)
FW	: Flash Welding (welding)	RSW	: Resistance Spot Welding (welding)
GMAW	: Gas Metal Arc Welding (welding)	SAW	: Submerged Arc Welding (welding)
GTAW	: Gas Tungsten Arc Welding (welding)	SMAW	: Shielded Metal Arc Welding (welding)
HAZ	: Heat Affected Zone (welding, thermal cutting)	STT	: Surface Tension Transfer (welding)
HB	: Brinell Hardness number (hardness)	SW	: Seam Welding (welding)
HF	: High Frequency (welding, brazing)	TIG	: Tungsten Inert Gas (welding)
HFIW	: High Frequency Induction Welding (welding)	UTS	: Ultimate Tensile Strength (N/mm <sup>2</sup> )
HR	: Hot Rolled (rolling)	UW	: Upset Welding (welding)
HRB	: Rockwell B. Hardness number (hardness)	WIG	: Wolfram Inert Gas (welding)
HRC	: Rockwell C. Hardness number (hardness)	YAG	: Yttrium-Aluminium-Garnet (laser welding, thermal cutting)
HSS	: High Speed Steels (machining)	YS	: Yield Strength (N/mm <sup>2</sup> )
HV	: Vickers Hardness number (hardness)		

## Reference list of illustrations and photo credits

- Cover: Bioreactor  
 manufacturer: Pierre Guérin Technologies, Mauze (F) – photo: idem
- 1: Bright annealing line  
 p. 5  
 manufacturer: Drever International, Liège (B) – photo: idem
- 2: Atomium, Brussels (B) p. 6  
 owner: asbl Atomium – architect : C. Conix – structural engineering : temporary association Bgroup – Geocal – photo: Thomas Pauly – © 2006 asbl Atomium – SABAM, Belgium 2006
- 3: Slitting line in action p. 24  
 manufacturer: Fagor Arrasate, Mondragon (E) – photo : idem
- 4: Hydraulic guillotine shear p. 29  
 manufacturer : LVD Company nv, Gullegem (B) – photo: idem
- 5: Coated carbide insert p. 41  
 manufacturer : Seco Tools AB, Fagersta (S) – photo: idem
- 6: Coated CERMET insert p. 41  
 photo: UGITECH, Ugine (F)
- 7: The glass-steel structure of the lens of the Rome yard p. 61  
 owner: Régie autonome des transports parisiens (RATP) – architect: Arté – Charpentier et associés – structural engineering : RFR Ingénieurs (Project engineer: Mitsu Edwards) – photo: Mitsu Edwards – © RATP
- 8: Hot extruded sections p. 62  
 manufacturer: Cefival, Persan (F) – photo : idem
- 9: Manual Gas Tungsten Arc Welding p. 64  
 photo: © 2006 ESAB, Gothenburg (S)
- 10: Fasteners p. 102  
 photo : Benoît Van Hecke
- 11: Milk pasteurizing plant p. 105  
 manufacturer: Pierre Guérin Technologies, Mauze (F) – photo: idem
- 12: Surface finishing p. 109  
 manufacturer: Otto Suhner, Brugg (CH) – photo: idem
- 13: Tensile testing p. 115  
 manufacturer: Zwick, Ulm (D) – photo: idem
- 14: Steam pressure cooker p. 118  
 manufacturer: SEB, Selongey (F) – photo: idem
- 15: Professional kitchen knife p. 125  
 manufacturer: Wüsthof, Solingen (D) – photo: idem
- 16: Pump casing p. 126  
 manufacturer: Ebara Pumps Europe, Cles (I) – photo: idem
- 17: Bulkhead panels for chemical tankers p. 126  
 manufacturer – shipyard: Cantieri Navali De Poli, Pellestrina (I) – photo: idem
- 18: Burner part p. 127  
 manufacturer: Bekaert Combustion Technology, Assen (NL) – photo: idem

## Bibliographical references

- 1 COLOMBIER (L), HOCHMANN (J), “Aciers inoxydables et Aciers réfractaires”, *Dunod*, Paris, 1965. English translation by Scripta Technica Ltd., Stainless and Heat Resistant Steels, Edward Arnold Publishers Ltd., London, 1967
- 2 “La construction chaudronnée en acier inoxydable”, Ugine Kuhlmann – aciers spéciaux, Paris, 1969
- 3 “La pièce mécanique en acier inoxydable”, Ugine Aciers, Paris, 1973
- 4 “Les aciers inoxydables” (ouvrage collectif), éditeurs scientifiques : LACOMBE (P), BAROUX (B) et BÉRANGER (G), les Editions de Physique, Les Ulis, 1990. English translation by DAVIDSON (J.H.) and LINDQUIST (J.B.), Stainless Steels, les Editions de Physique (Publishers), les Ulis, 1993
- 5 CUNAT (P-J), « Aciers inoxydables. Critères de choix et structure (M 4 540); Propriétés. Résistance à la corrosion (M 4 541); Mise en œuvre (M 4 542); Fabrication (M 4 543) », Techniques de l'Ingénieur, traité Matériaux métalliques, Paris, 2000. English translation by Davidson (J.H.), The Euro Inox Handbook of Stainless Steel, Euro Inox, Luxemburg, 2002.
- 6 “Design Manual for Structural Stainless Steel”, Third Edition, Luxembourg: Euro Inox 2006
- 7 “Guide du collage de l'acier inoxydable / Guide to adhesive bonding of stainless steel”, Document Ugine, *La Défense*, 1996
- 8 Association Ouvrière des Compagnons du Devoir du Tour de France et la collaboration de G. Murry, coordinateur, Travailler l'Acier – Manuel de l'Artisan et du Technicien, Editions *SIRPE*, Paris, 1996 .
- 9 MOIRON (J-L) avec le concours de BONNEFOIS (B) et CUNAT (P-J), “Souder les aciers inoxydables”, *SIRPE*, Paris, 2000