



ENGINEERING-PDH.com
ONLINE CONTINUING EDUCATION

INVESTIGATION OF HIGH ENERGY BLAST SOUND PROPOGATION

Main Category:	Mechanical Engineering
Sub Category:	-
Course #:	MEC-141
Course Content:	50 pgs
PDH/CE Hours:	3

OFFICIAL COURSE/EXAM
(SEE INSTRUCTIONS ON NEXT PAGE)

WWW.ENGINEERING-PDH.COM

TOLL FREE (US & CA): 1-833-ENGR-PDH (1-833-364-7734)

SUPPORT@ENGINEERING-PDH.COM

MEC-141 EXAM PREVIEW

- TAKE EXAM! -

Instructions:

- At your convenience and own pace, review the course material below. When ready, click “Take Exam!” above to complete the live graded exam. (Note it may take a few seconds for the link to pull up the exam.) You will be able to re-take the exam as many times as needed to pass.
- Upon a satisfactory completion of the course exam, which is a score of 70% or better, you will be provided with your course completion certificate. Be sure to download and print your certificates to keep for your records.

Exam Preview:

1. Blast noise is a phenomenon unique to the military. It consists of short duration events that are rich in high-frequency acoustical energy.
 - a. True
 - b. False
2. The sound events were produced by detonation of approximately ____ lb(s) of C4 explosive, cut into two approximately equal parts, folded over, and held together by a minimum of light tape or other means, mutually acceptable to ERDC and installation staff, to satisfy both technical and safety requirements.
 - a. 1.0
 - b. 1.25
 - c. 2.5
 - d. 5.0
3. According to the reference material, the general measurement layout for all four experiments was similar. Sensors were located on three measurement arms separated by approximately ____°
 - a. 30
 - b. 60
 - c. 120
 - d. 180
4. According to the reference material, the required bandwidth of pressure waveform recordings was 20 kHz at distances less than 1 km and 5 kHz at longer distances.
 - a. True
 - b. False

5. According to the reference material, the charges were suspended ___m above the ground, and located within an accuracy of a few inches, using an apparatus (sling) supplied by ERDC.
 - a. 3
 - b. 4
 - c. 5
 - d. 6
6. The SAMS meteorological data included information for the 12-day period with 30-minute updates of the measured temperature, wind speed, wind direction, maximum gust, barometric pressure, relative humidity, precipitation, solar radiation, and any available calculated parameters.
 - a. True
 - b. False
7. According to the Sound sampling and measurement section of the reference material, the blast pressure signature of all charges detonated was measured during the data sessions using ___ pencil gauges located at 4m radius.
 - a. 3
 - b. 4
 - c. 5
 - d. 6
8. According to the reference material, the “far-field” locations were 1, 2, 4, 8, 12, 16 km from the blast site, as feasible. The A16 site was not used in this experiment as there was not a road completely up to this mountainside location.
 - a. True
 - b. False
 - c.
9. The detailed daily setup procedure provides direction and insight on the day-to-day setup and calibration of all the equipment used. According to this reference material, what operating amperage was needed to operate the Vaisala tethered weather balloons?
 - a. 15
 - b. 20
 - c. 25
 - d. 30
10. According to the reference material, the first field session took place at WSMR from 11–20 August 2007. Sensors were placed on three measurement arms, forming a “Y” shape, with the base directed approximately South-Southwest.
 - a. True
 - b. False

Contents

Abstract	ii
Figures and Tables.....	iv
Preface.....	vi
1 Introduction.....	1
1.1 Background.....	1
1.2 Objectives.....	2
1.3 Approach.....	2
1.3.1 General description of experiments.....	2
1.3.2 Selection of experimental sites.....	3
1.3.3 Sound sampling and measurement.....	3
1.3.4 Meteorology sampling and measurement.....	6
1.3.5 Measurement layout.....	8
1.3.6 Sampling schedule.....	9
1.4 Safety and security plan.....	10
1.5 Scope.....	11
1.6 Mode of technology transfer.....	11
2 First Field Session: WSMR, August 2007.....	12
2.1 Experimental layout.....	12
2.2 Sound sampling and measurement.....	12
2.3 Meteorology sampling and measurement.....	13
2.4 Acoustic equipment specifications.....	18
2.5 Calibration procedures.....	18
2.5.1 B&K outdoor microphone calibration.....	18
2.5.2 Instructions for calibration of far-field equipment.....	23
2.6 Detailed daily setup procedures.....	24
2.6.1 RION DA-20 (far-field acoustic sensors).....	24
2.6.2 Vaisala tethersonde weather balloons.....	26
2.7 Sampling schedule.....	34
3 Second Field Session: WSMR, January 2008.....	36
3.1 Experimental layout and details.....	36
3.2 Sampling schedule.....	39
4 Third Field Session: FLW, August 2008.....	40
4.1 Experimental layout and equipment details.....	40
4.2 Sampling schedule.....	43
5 Fourth Field Session: FLW, March 2009.....	44
5.1 Experimental layout and equipment details.....	44
5.2 Sampling schedule.....	44
6 Conclusion.....	45
Acronyms and Abbreviations.....	46
Report Documentation Page (SF 298).....	47

Figures and Tables

Figures

1-1	Demolition charge configuration.....	5
1-2	Demolition charge being aligned for detonation	5
1-3	Tethersonde balloon in flight.....	7
1-4	Sondes being attached to the tethersonde cable	8
1-5	Representative meteorological tower,.....	9
2-1	Layout for the first field session at WSMR (August 2007), including locations of all sensors. (Tbl. 2-1 lists exact locations.).....	14
2-2	Representative remote acoustical measurement station	19
2-3	Representative instrumentation box for remote acoustical measurement station.....	19
2-4	Calibration procedure in process. (The calibrator is the black cylinder placed on top of the tripod.)	20
2-5	Example calibration checklist for the far-field sites	20
2-6	A RION unit that has been properly setup and is ready to begin collecting data.....	26
2-7	Connection diagram for the tethersonde electronics. Beware: 9-pin control line, marked with red tape, has a short special cable section on the PC end with a very fragile connector that goes into the PC mother board through the side of the PC	29
2-8	Example shot time log.....	35
4-1	The far-field locations of the equipment for the equipment at FLW. The locations of the equipment were the same for both experiments at this location (August 2008 and March 2009).....	40

Tables

2-1	Sensor locations and equipment details for all acoustic and meteorological sensors used at WSMR in August 2007. (Fig. 2-1 shows a chart of all sensor locations.).....	15
2-2	UTM coordinates for the 4DWX weather node locations	16
2-3	Sensors at each height on the weather towers and the number of channels required in the HOBO data logger	17
2-4	Serial numbers for the sensors used on the three weather towers A924, B7, and C7. Equipment manufacturer: Onset Computer Corp, Model: HOBO Weather Station	17
2-5	Serial numbers for the equipment used at the A-line sensors in the WSMR experiment, August 2007	21
2-6	Serial numbers for the equipment used at the B-line sensors in the WSMR experiment, August 2007	21
2-7	Serial numbers for the equipment used at the C-line sensors in the WSMR experiment, August 2007	22

2-8	Serial numbers for the equipment used in the WSMR experiment, August 2007	22
3-1	Sensor locations and equipment details for all acoustic and meteorological sensors used at WSMR in January 2008	37
3-2	Model and serial numbers for the 125m microphone locations, WSMR Experiment #2, January 2008	38
3-3	Serial numbers for the sensors used on the four weather towers G0, A-WT, B-WT, and C-WT. Equipment manufacturer: Onset Computer Corp; Model: HOBO Weather Station	38
4-1	Coordinates for the sensors used in the August 2008 and March 2009 experiments at FLW	41
4-2	Specifications for the calibrators used at the FLW experiment in August 2008.....	42
4-3	Model and serial numbers for the 125m microphone locations, FLW experiment, August 2008	42
4-4	Serial numbers for the RION DA-20 4-Channel Digital Data Recorders used at each site in the August 2008 FLW experiment	42
5-1	Model and serial numbers for the 125m microphone locations, FLW experiment, March 2008.....	44

Preface

This study was conducted for the U.S. Army Public Health Command (USAPHC) as part of the Operational Noise Discrete Events: Physics Models Environmental Quality Technology (EQT) Program under Project Do48, “Industrial Operations & Pollution Control Technology,” Work Unit C43279 “Blast Propagation Data Analysis.” The technical monitor was Ms. Catherine Stewart, MCHB-IP-EON.

The work was performed by the Ecological Processes Branch (CNN) of the Installations Division (CN), Construction Engineering Research Laboratory (CERL), and the Signature Physics Branch (CEERD-RRD), Cold Regions Research and Engineering Laboratory (CRREL). The CERL Principal Investigator was Dr. Larry L. Pater. At the time of publication, Dr. Chris C. Rewerts was Chief, CEERD-CNN, and Ms. Michelle J. Hanson was Chief, CEERD-CN. The associated Technical Director was Mr. Alan B. Anderson. The Director of CERL was Dr. Ilker R. Adiguzel.

COL Bryan S. Green was Commander of ERDC, and Dr. David W. Pittman was the Director.

1 Introduction

1.1 Background

Blast noise is a phenomenon unique to the military. It consists of short duration events that are rich in low-frequency acoustical energy. These events are characterized by high energies that can be loud at distances of many tens of kilometers from the source. While the impulsiveness, intermittency of events, and large amount of low-frequency energy are typically considered to be the main factors contributing to the uniqueness of blast noise, the receiver of the noise (human, animal, structure) ultimately dictates the sound characteristics of interest.

Regardless of which characteristics of the noise one focuses on, atmospheric conditions greatly affect the propagation of sound. This is due to the long distances these sounds travel as they move through the atmosphere. Available meteorological models accurately predict vertical sound speed profiles only up to the top of the boundary layer, and little information exists regarding the amount of variation in level and spectra of blast noise that is caused by changing meteorological conditions along the propagation path. For long-range propagation, this is inadequate. There is a need to better understand refraction in the atmosphere, especially in the outer layer.

Available blast noise datasets suffer from a number of limitations. Many have inadequately defined meteorological profiles or a lack of accurate acoustic recordings of noise events, particularly of the spectral distribution of sound exposure level and the evolution of pressure waveforms. The use of modern digital instrumentation and automated procedures can overcome such limitations to obtain an extensive set of both acoustical and meteorological data, which can be used to guide and test analytical algorithms. This work was undertaken to provide a dataset —specifically, vertical sound speed profile data and resulting propagation effects— that may be used to better explain the effects of atmospheric refraction in sound propagation. Requirements for this research are based in Army Environmental Requirements and Technology Assessments (AERTA) requirement 2.4.f, U.S. Department of Defense (DoD) Instruction 4715.13, and Army Regulation (AR) 200-1.

1.2 Objectives

The objectives of this work were to measure an extensive set of high-energy impulsive pressure waveforms and simultaneous meteorological data at various distances, and to produce a definitive dataset for the effects of a wide range of meteorological conditions on long-range high-energy blast sound propagation in climate types similar to the majority of continental United States (CONUS) military installations (arid desert and temperate vegetated).

1.3 Approach

1.3.1 General description of experiments.

Technical aspects of the experiments were developed in a series of meetings and telephone calls, and, most importantly, during an acoustics workshop hosted by ERDC-CERL on 6–7 February 2007. Workshop participants designed large-scale coordinated experiments that would provide data needed by ERDC acoustical research thrusts, including battlefield acoustics, ground sensor development, and discrete blast event propagation. A list of important parameters and questions requiring measurement were prioritized to control the project scope. Consensus was obtained on the formulation of data measurement goals by the subject matter expert attendees. The required acoustic metrics and environmental data were chosen that would most appropriately support the development of the analysis products.

Workshop topic sessions included all aspects regarding measurement, instrumentation, and sound sources. In addition, the field experiment schedule; the spatial layout of sensors; the selection of experimental sites; and the methods of data analysis, archiving, and analytical calculations were also discussed. The experiments were designed to employ fail-safe equipment, to achieve redundancy in processes and supplies, to minimize complexity and potential for human error, to protect against environmental hazards, to achieve positive identification of signal vs. noise, and to eliminate weather preference bias.

Sixteen subject matter experts from several organizations participated in the workshop, including end-product users from the U.S. Army Center for Health Promotion and Preventive Medicine (USACHPPM) (now known as the U.S. Army Public Health Command [USAPHC]) Operational Noise Program, and researchers from the University of Illinois, ERDC-CERL,

and ERDC-CRREL. It should be noted that ERDC-CERL has been the lead Army laboratory for training noise research and development (R&D), ERDC-CRREL has significant capability with respect to battlefield identification and tracking of vehicles, and U.S. Army Public Health Command (PHC) provides noise management consultation to DoD installations.

Four field experiments were conducted from August 2007 through March 2009. Two of the experiments took place at White Sands Missile Range, NM (WSMR) in August 2007 and January 2008. Two field experiments were conducted at Fort Leonard Wood, MO (FLW) in August 2008 and March 2009.

1.3.2 Selection of experimental sites

The technical objective of this work was to develop a definitive experimental dataset for effects of a wide range of meteorological conditions on long-range sound propagation for pertinent climate types (arid desert and temperate vegetated). Based on the desired climate types, WSMR was chosen as the first site for this experiment. This arid region is similar to other major installations in the southwestern United States. FLW was chosen as the second site because the weather and vegetation is typical of many installations located within forested and temperate regions. In addition, a FLW data set, obtained approximately 25 years ago, was available for comparison.

1.3.3 Sound sampling and measurement

Automated digital instrumentation was used to measure the received sound pressure from a consistent and repeatable blast sound source for a wide variety of accurately documented weather conditions. The sound source was provided by the detonation of an approximately 1.25 lb C4 explosive charge yielding a pressure waveform representative of large military weapons, such as tanks and artillery. Sound pressure waveforms were recorded at distances ranging from 4m to 16 km (9.9 miles) in three azimuthal directions from the source location. The sites were chosen to take advantage of existing roads, both to facilitate the experiment and to avoid damage to environmental and cultural resources on each installation. The experiments sampled upwind, downwind, and crosswind sound propagation under a wide variety of weather conditions. Measurements were taken throughout the day and night at several times of the year to study daily and seasonal effects on sound propagation. Sound data of interest included the waveform, peak,

sound exposure level (SEL) C-, A- and flat-weighted one-third-octave-band SEL spectra, and ambient Equivalent Average Sound Level (LEQ).

The quality of the experimental data was ensured through careful planning and peer review. The procedures used in the experimental measurement of blast wave parameters conformed to national and international standards. All measurements were made using carefully set up and checked instrumentation systems and standardized traceable calibration procedures.

Blast sound events were produced according to the sampling schedules detailed in the respective sections of this report. The sound events were produced by detonation of approximately 1.25 lb (one stick) of C4 explosive, cut into two approximately equal parts, folded over, and held together by a minimum of light tape or other means, mutually acceptable to ERDC and installation staff, to satisfy both technical and safety requirements. Each C4 charge was weighed and the weight recorded to within an accuracy of 0.5 oz. A log of the time of each blast was recorded to within an accuracy of 1 minute.

The charges were suspended 3m above the ground, and located within an accuracy of a few inches, using an apparatus (sling) supplied by ERDC. Figure 1-1 shows the sling with a charge in place. Explosives are attached to a rope draped over the wire placed between the poles. Charge height was set before each detonation by aligning the charge height with a precision-length steel pipe (not shown). Figure 1-2 shows an example of a suspended charge undergoing height alignment; the block of C-4 has been split in two, folded over, and taped, and the charge height is being set using the precision-length steel pipe as a guide.

After WSMR and FLW approval was obtained, at two times during each field experiment, when atmospheric conditions were reasonably stable and conditions were otherwise favorable, the research team fired, in fairly rapid succession (intervals of a few minutes, i.e., as quickly as possible commensurate with safety) C4 charges of 2.5 and 5 lb. Firing C4 charges of 10 and 20 lb were also considered. However, it was ultimately determined the sound equipment would not be able to withstand the blast noise from these higher weight explosives.

Figure 1-1. Demolition charge configuration.



Figure 1-2. Demolition charge being aligned for detonation.



1.3.4 Meteorology sampling and measurement

Meteorological conditions were documented by a variety of techniques from ground level to about 1600m altitude above ground level (AGL) at WSMR and 2000m at FLW. Meteorology data of primary interest were temperature, wind speed, and wind direction. In addition, relative humidity, barometric pressure, precipitation, and solar radiation were documented.

Two Vaisala digital tethersonde systems were used during the data sessions. Their locations are described in the body of this report, in the respective sections for each experiment. The balloons were 9m³ with a 2 km tether. Six sondes were spaced at approximately 330m intervals on the tether wire, with the highest one as close as prudent to the balloon. The sondes were in place and taking data at least 20 minutes before the beginning of each data session. During a data session, the sondes were held on station for about 20 minutes, then reeled in on the tether until the lowest sonde was near the ground (required about 20 minutes at about 1 ft/sec, winch supply voltage about 12 volts DC), and then reeled out at the same speed to the original heights. This procedure was repeated throughout the data session. Figures 1-3 and 1-4, respectively, show the tethersonde balloon in flight and the sondes being attached to the tethersonde cable.

The sondes were also held on station with data obtained at least 20 minutes after the last blast event. This procedure allowed sampling both the temporal variation at (more or less) constant heights, and sampling the vertical profile in detail. The time-synchronized data obtained from the tethersonde included temperature, wind speed, wind direction, relative humidity, and barometric pressure. The maximum available data sample rate was used. The meteorological data was provided in electronic format. An instrument trailer was located at each tethersonde site. For the WSMR field sessions, ERDC-CERL provided one trailer and WSMR provided the second trailer. For the FLW field sessions, ERDC-CERL provided both instrument trailers.

Figure 1-3. Tethersonde balloon in flight.



Figure 1-4. Sondes being attached to the tethersonde cable.

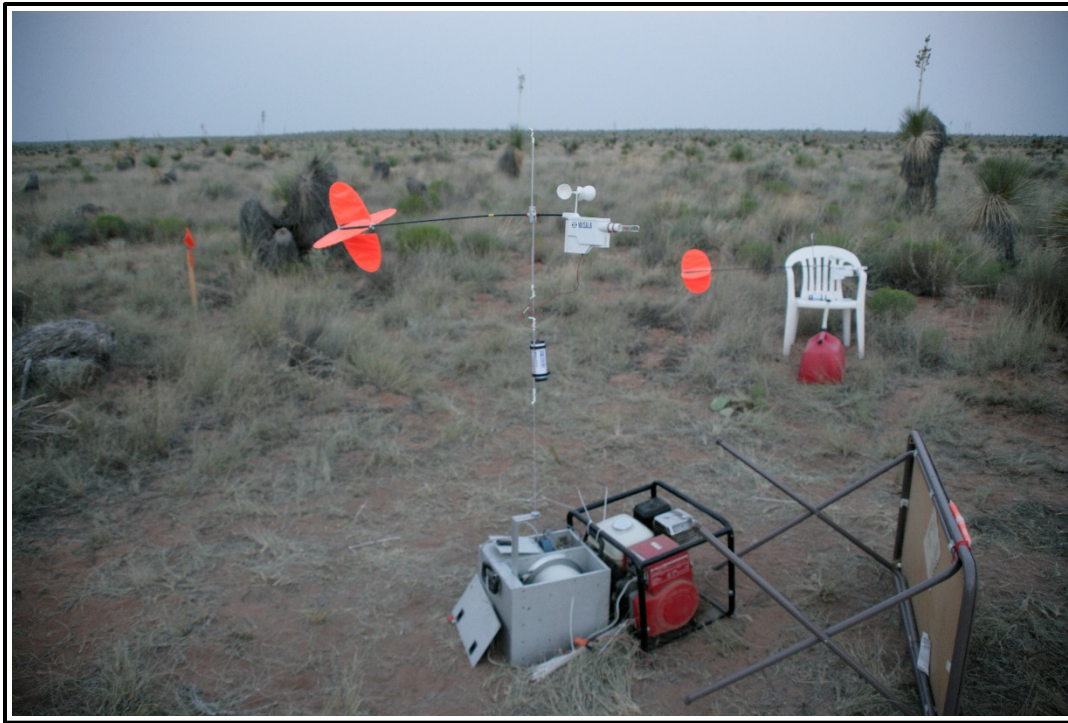

ERDC-CERL erected three weather towers for the first experiment at WSMR. For the second WSMR experiment and for both FLW experiments, an additional fourth weather tower was erected near ground zero. Figure 1-5 shows one of the towers. All the weather data gathering equipment were located on towers. If a weather sensor failed during the experiment (except those at 1m and 3m heights that were easily accessible near the ground) due to safety concerns associated with the tower height. However, any failed weather sensors were replaced prior to the next site experiment.

1.3.5 Measurement layout

The general measurement layout for all four experiments was similar. Sensors were located on three measurement arms separated by approximately 120° . Differences in each of the four particular experiments are included in the body of this report. The required bandwidth of pressure waveform recordings was 20 kHz at distances less than 1 km and 5 kHz at longer distances. Site locations for measurement equipment along roads that carried significant traffic were placed approximately 50m to 75m away from the road to minimize traffic noise interference with the sound data recordings.

Figure 1-5. Representative meteorological tower,



1.3.6 Sampling schedule

The sampling schedule for each experiment is detailed in the respective sections of this report. To obtain blast data diurnally, different time sessions throughout the 24-hour cycle were conducted. The C4 sound events, and the sound and meteorological measurements, took place during each data session.

The controlled blast sound events occurred at 20-minute intervals during each data session. Although the 20-minute time interval between charges

was not exactly accurate, the time interval did not vary by more than a minute or two, and the charges at the top of the hour were as timely as reasonably feasible.

The total available recording time, including calibration, of the RION recorders (located at ranges ≥ 1 km) at 5 kHz bandwidth exceeded 11 hours, thus 11-hour sessions were initially planned for the experiments. Timers for the recorders for the first field session at WSMR were scheduled to be turned on about 2 minutes before each data session. And the recording time was set to expire about 3 minutes after the data session ended. However, due to the human fatigue factor, the actual data sessions were shortened and this allowed the RION data recorders to gather data for $\frac{1}{2}$ hour before the start of the blasting session, and to continue for 1 hour after the blasting session had concluded. (See the “Sampling schedule” for each experiment for specific details.)

Precise timing of propagation was accomplished via Inter-Range Instrumentation Group (IRIG) time code generators at each pressure sensor location. Collection of data recordings and calibration of instruments were accomplished during daylight hours. For the first WSMR field experiment, only pre-calibration of the equipment was performed. However, with the shorter data sessions for the second WSMR experiment and both field sessions at FLW, pre-calibration and post-calibration of the equipment were performed. Field setup of the equipment was scheduled for approximately 6 days prior to the start of the data session, with the last day reserved for a dry run or as a make-up day in case rain impacted the schedule. Approximately 4 days were allocated to pack the equipment after the final data session.

To sample seasonal variations, the experiments at WSMR were conducted in August 2007 and January 2008 and the experiments at FLW took place in August 2008 and March 2009.

1.4 Safety and security plan

All activity connected with these experiments were conducted in conformance with WSMR and FLW rules, regulations, and policies. All ERDC personnel associated with the project were governed by, and complied with, installation regulations and instructions to ensure safety and security. The firing officer at each respective installation was in charge of the firing

events and all personnel on the test site. All personnel were located inside approved shelters during detonation and wore adequate hearing protective devices during the noise events.

1.5 Scope

This stage of research focused on data gathering; procedures for reduction of the data and preparation for analysis are described in:

D. Valente, L. Ronsse, R. D. Serwy, J. Barr, K. Claffey, M. J. White, and M. E. Swearingen. 2012. Data preparation procedures for the ERDC high-energy large-scale blast sound propagation experiment. ERDC/CERL TR-12-12. Champaign, IL: Engineer Research and Development Center, Construction Engineering Research Laboratory (ERDC-CERL).

1.6 Mode of technology transfer

It is anticipated that the results of this work will guide the creation of analytical models and test computational algorithms aimed at predicting blast noise level around military installations. This report will be provided directly to the Operational Noise Program of the U.S. Army Public Health Command (USAPHC) (the Army technical transfer agent for and primary user of military blast noise technology) and to other known users.

2 First Field Session: WSMR, August 2007

2.1 Experimental layout

The first field session took place at WSMR from 11–20 August 2007. Sensors were placed on three measurement arms, forming a “Y” shape, with the base directed approximately North-Northeast. Each of these arms (or “lines”) were notated with a letter (A, B, or C). The blasting site (ground zero) is labeled as Go. The sensor locations were labeled with a letter-number pair according to the line on which the sensor resided and at what distance. For example, a sensor 12 km from ground zero on the A-line is labeled as Station A12. The map in Figure 2-1 shows the experimental layout with topography, and all sensor locations.

Distances for the “near-field” sites were 4, 31, 125, and 500 m; and the “far-field” locations were 1, 2, 4, 8, 12, 16 km from the blast site, as feasible. The A16 site was not used in this experiment as there was not a road completely up to this mountainside location. For the C-line, the furthest location was just within the installation’s fenceline at 15 km (rather than 16 km) from the blast site. Table 2-1 lists the locations of all sensors, both acoustic and meteorological.

2.2 Sound sampling and measurement

Blast sound events were produced according to the sampling schedule at ground zero, located near the eastern edge of the 649 WIT* circle (Figure 2-1). Site No. 649 WIT was the area the researchers referred to whenever they communicated with range control personnel. The entire 649 WIT area was closed off as a safety zone during the blasting sessions.

The blast pressure signature of all charges detonated was measured during the data sessions using six pencil gauges located at 4m radius (Table 2-1). Digitized pressure waveform files in American Standard Code for Information Interchange (ASCII) format, registered to time, were obtained. ERDC provided a global positioning system (GPS) time mark generator of the same type as, and synchronized with, the time mark generators at the

* Warhead Impact Target (WIT); 649 WIT is a Phase 1 impact area used to test non-lethal submunitions.

acoustical measurement sites to be recorded with the blast gauges. These data were used to determine yield and directivity of the C4 charges.

2.3 Meteorology sampling and measurement

WSMR has three types of permanent weather stations on the installation that collect meteorological data, comprised of: (1) 924 MHz radar atmospheric profiler, (2) SAMS (Surface Automated Measuring System), and (3) 4DWX (Four Dimensional Weather Model). The 924 MHz radar profiler site (Site #A-924 in Table 2-1) is located near Site No. 649 WIT, which served as a primary reference point. The SAMS sites include STR#12, GRJ#8, GAP#6, and DUG#19 (Table 2-1). Table 2-2 lists the 4DWX node locations.

The 924 MHz atmospheric profiler data included measured and calculated meteorological parameters at the smallest available altitude intervals. The primary research interest was up to 2 km AGL, on a 24-hour basis, for the duration of the 10-day data session period, including the day prior and the day after the data session (a total of 12 days). These data included temperature, wind speed, and wind direction. In addition, data were obtained for any other 924 MHz systems that were installed at any site within 20 km of No. 649 WIT. Accuracy specifications for all parameters for the 924 MHz systems were recorded.

The SAMS meteorological data included information for the 12-day period with 15 minute updates of the measured temperature, wind speed, wind direction, maximum gust, barometric pressure, relative humidity, precipitation, solar radiation, and any available calculated parameters. Accuracy specifications were obtained for all parameters.

A complete set of the 4DWX model forecast data, provided at the most frequent update time interval, at each 3.3 km node within 20 km of #649 WIT was obtained. Noise Assessment and Prediction System (NAPS) sound predictions were obtained at the same times, at the measurement sites listed in Table 2-1 and also at the node locations listed in Table 2-2. Information regarding statistical reliability expectations for all parameters was also obtained.

Table 2-1. Sensor locations and equipment details for all acoustic and meteorological sensors used at WSMR in August 2007. (Fig. 2-1 shows a chart of all sensor locations.)

Site	Azimuth	Range (m)	UTM* Coordinates, Zone 13S (m)			Notes
	(Ref. Source Location)		Easting	Northing	Elevation	
G-0	0.0	0	352240	3723172	1428	Source, h = 3m
BG-A	68.0	4	N/R	N/R	1427	Note 6
BG-AB	138.0	4	N/R	N/R	1427	Note 6
BG-B	208.0	4	N/R	N/R	1427	Note 6
BG-BC	248.0	4	N/R	N/R	1427	Note 6
BG-C	288.0	4	N/R	N/R	1427	Note 6
BG-CA	358.0	4	N/R	N/R	1427	Note 6
A31	68.0	31	352269	3723184	1428	Note 3
A125	68.0	125	352356	3723219	1428	Note 4
A500	68.0	500	352704	3723359	1429	Note 5
B31	208.0	31	352225	3723145	1428	Note 3
B125	208.0	125	352181	3723062	1428	Note 4
B500	208.0	500	352005	3722731	1428	Note 5
C31	288.0	31	352211	3723182	1428	Note 3
C125	288.0	125	352121	3723211	1428	Note 4
C500	288.0	500	351764	3723327	1428	Note 5
A1	68.0	1,000	353167	3723547	1430	Note 1
A2	68.3	2,000	354098	3723913	1432	Note 1
A2T	68.3	2,000	354098	3723913	1432	Note 2
A4	69.0	4,000	355975	3724605	1430	Note 1
A4T	69.0	4,000	355975	3724605	1430	Note 2
A8	68.8	8,000	359697	3726070	1443	Note 1
A8T	68.8	8,000	359697	3726070	1443	Note 2
A12	68.8	12,221	363636	3727586	1511	Note 1
B1	211.3	1,000	351720	3722318	1427	Note 1
B2	202.0	2,000	351492	3721317	1426	Note 1
B4	207.9	4,000	350368	3719637	1427	Note 1
B8	211.3	8,000	348086	3716335	1428	Note 1
B12	208.7	12,000	346485	3712642	1425	Note 1
B16	208.4	16,000	344636	3709094	1427	Note 1
C1	285.8	1,000	351278	3723444	1428	Note 1
C2	286.7	2,000	350324	3723746	1428	Note 1
C4	293.3	4,000	348567	3724757	1427	Note 1
C8	290.0	8,000	344721	3725905	1441	Note 1

* Universal Transverse Mercator (UTM) (coordinate system).

Site	Azimuth	Range (m)	UTM* Coordinates, Zone 13S (m)			Notes
	(Ref. Source Location)		Easting	Northing	Elevation	
C12	286.1	12,008	340705	3726509	1447	Note 1
C15	288.9	15,265	337800	3728122	1452	Note 1
A-924	69.8	2,985	355042	3724202	1434	Note 9
A924WT	69.8	2,985	355042	3724202	1434	Note 8
B7T	211.1	7,000	348628	3717176	1430	Note 7
B7WT	210.7	6,903	348718	3717235	1430	Note 8
C7T	290.4	7,000	345678	3725610	1433	Note 7
C7-WT	290.7	6,910	345775	3725612	1433	Note 8
STR#12	346.1	20,601	347293	3743170	1487	Note 10
GRJ#8	301.2	8,687	344809	3727671	1453	Note 10
GAP#6	129.1	17,417	365760	3712192	1633	Note 10
DUQ#19	100.7	10,828	362880	3721164	1499	Note 10

¹ Brüel & Kjær (B&K) 4921 outdoor microphone ½ in., 1.5 m height on tripod, Rion recorder (ERDC).
² 15 m tower, five microphones, Liberty recorder (ERDC), 8 guy wires on 25 ft and 50 ft radius, stakes up to 2 ft deep.
³ 1/8-in. microphone, 1.5 m tripod, Yokagawa recorder (ERDC).
⁴ ¼-in. microphone, 1.5 m tripod, Yokagawa recorder (ERDC).
⁵ B&K 4921 outdoor microphone ½-in., 1.5 m height on tripod, Yokagawa recorder (ERDC).
⁶ Blast gauge, h = 3 m (WSMR).
⁷ Tethersonde (1 ERDC, 1 WSMR) and met ground station (ERDC).
⁸ 15 m weather data tower (ERDC), eight guy wires on 25 ft and 50 ft radius circle, stakes up to 2 ft deep.
⁹ 924 MHz atmospheric profiler (WSMR).
¹⁰ SAMS Site (WSMR).

Table 2-2. UTM coordinates for the 4DWX weather node locations.

Easting	Northing
355042	3724202
349648	3716221
346283	3726357

In addition, ERDC-CERL erected three 15m weather towers (Sites #A924WT, #B7WT, and #C7-WT). Table 2-3 lists information regarding the type of sensor and the number of data logger channels required for the weather towers. Table 2-4 lists the serial numbers of the equipment used at the weather towers.

Table 2-3. Sensors at each height on the weather towers and the number of channels required in the HOBO data logger.

Height (m)	Anemometer	Temp 12 bit	RH/Temp 8 bit	Solar Rad.	Bar. Press.	Precip.	Soil moisture	Total Channels
15	3	1						4
10	3	1	2					6
6	3	1						4
3	3	1	2					6
1		1		1	1	1		4
0							1	1
Total Channels	12	5	4	1	1	1	1	25

Table 2-4. Serial numbers for the sensors used on the three weather towers A924, B7, and C7. Equipment manufacturer: Onset Computer Corp, Model: HOBO Weather Station.

Site No. A924WT	Serial Nos.		
Loggers	725908	724625	
Barometric pressure	718076		
Solar radiation	730730		
Soil moisture	986131		
Rain gauge	668179		
	Anemometer Serial #	Temp. 12 bit Serial #	Temp, 8 bit Serial #
1 meter		732770	
3 meters	991684	732773	725372
6 meters	716311	1000055	
10 meters	713657	732766	725363
15 meters	713662	*	
Site No. B7WT	Serial Nos.		
Loggers	724608	724627	
Barometric pressure	718073		
Solar radiation	730732		
Soil moisture	1001459		
Rain gauge	668172		
	Anemometer Serial #	Temp. 12 bit Serial #	Temp, 8 bit Serial #
1 meter		732772	
3 meters	713665	732762	725365
6 meters	713658	732761	
10 meters	716310	732767	725357
15 meters	981368	*	

Site No. C7WT	Serial Nos.		
Loggers	724619	724611	
Barometric pressure	718074		
Solar radiation	730735		
Soil moisture	1001458		
Rain gauge	668170		
	Anemometer Serial #	Temp. 12 bit Serial #	Temp, 8 bit Serial #
1 meter		732769	
3 meters	981383	732765	725373
6 meters	991685	732760	
10 meters	713666	732763	725385
15 meters	965682	*	
*Equipment was on order and was not available for this first experiment.			

2.4 Acoustic equipment specifications

Tables 2-5 through 2-8 list the serial numbers of the equipment and sensitivity for the microphones used in this experiment.

2.5 Calibration procedures

2.5.1 B&K outdoor microphone calibration

Microphones were calibrated daily and fixed as soon as possible. Calibration of each microphone (with the exception of the blast pencil gauges) was conducted before and after each data session. There was no field calibration for the blast pencil gauges, as they were calibrated by the manufacturer before and after each experiment. However, field personnel tapped on each pencil gauge to test for a signal prior to each data session. The blast pencil gauges were mounted on top of a 10-ft tall, 1½-in. diameter galvanized steel pipe using a tee connector for mounting. This was then threaded onto a 2-ft diameter plate, which was weighted down with sandbags.

The following section lists the calibration procedures used for the B&K Outdoor Microphone Assembly Unit, Model No. 4921 and the B&K ½-in. diameter Microphone, Model No. 4149. These calibration procedures were for the far-field equipment (distances of 1 km or greater from ground zero). Figure 2-2 shows a representative remote station; Figure 2-3 shows the interior of the instrumentation box, and Figure 2-4 shows the calibration in process. There were no written calibration procedures for the near-field equipment. Figure 2-5 shows an example calibration checklist.

Figure 2-2. Representative remote acoustical measurement station.



Figure 2-3. Representative instrumentation box for remote acoustical measurement station.



Figure 2-4. Calibration procedure in process. (The calibrator is the black cylinder placed on top of the tripod.)



Figure 2-5. Example calibration checklist for the far-field sites.

RION Calibration Checklist											
Date	Time	Site	mV Reading	Who?	TCG light 1/sec	Charge Controller Status	Verified Rion date/time	Verified Timer day/time	Verified Trig. Setting (single)	Verified Timer on	Verified Trigger light blinking
18 AUG 2007	1429	C1	RUNNING 599mV	JEFF	YES	FULL	YES	YES	YES	AUTO	YES
18 AUG 2007	1438	C2	RUNNING 1.213mV	JEFF	YES	FULL	YES	YES	YES	AUTO	YES
18 AUG 2007	1455	C4	RUNNING 758mV	JEFF	YES	FULL	YES	YES	YES	AUTO	YES
18 AUG 2007	1512	C8	RUNNING 495mV	JEFF	YES	FULL	YES	YES	YES	AUTO	YES
18 AUG 2007	1525	C12	RUNNING 516mV	JEFF	YES	FULL	YES	YES	YES	AUTO	YES
18 AUG 2007	1540	C15	ONED FULL 605mV	JEFF	YES	FULL	YES	YES	YES	AUTO	YES

Expect 1km: 600mV; 2km: 1200mV; 4km: 750mV; 8km: 500mV; 12km: 600mV; 16km: 600mV

Form Revised 8/13/2007

Table 2-5. Serial numbers for the equipment used at the A-line sensors in the WSMR experiment, August 2007.

Site Location	A1	A2	A4	A8	A12	A31	A125	A500
RION DA-20 4-Channel Digital Data Recorders	11060617	11060616	10270723	10270720	10270729			
B&K Outdoor Microphone Assembly Unit Model No. 4921	1478069	1478056	1444361	1444354	1478047			717944
B&K ½ in. diameter Microphone Model No. 4149	1328990	1329019	1410173	1649052	1615178			1064759
B& K Microphone Power Supply Model No. 2804						1533634	1466064	
B&K Preamplifier Model No. 2639						1246193	1497489	
B&K Microphone Model No. 4149						2510332	52398	
Sensitivity @ 250 Hz (mV/Pa)	12.68	12.62	12.96	12.2	11.61	0.764 @ 251.2 Hz	3.46	
Calibration voltage	600mV	1200mV	750mV	500mV	600mV			300mV

Table 2-6. Serial numbers for the equipment used at the B-line sensors in the WSMR experiment, August 2007.

Site Location	B1	B2	B12	B4	B8	Spare	B16	B31	B125	B500
RION DA-20 4-Channel Digital Data Recorders	1106061-9	1106061-8	1027072-5	1027072-7	1027071-8	102707-19	10270-715			
B&K Outdoor Microphone Assembly Unit Model No. 4921	1167053	1444364	1395777	1395772	1395767	546456	14780-64			56256-0
B&K ½-in. diameter Microphone Model No. 4149	1410212	1227286	1649058	1329034	1756492	1152408	10648-31			10648-07
B& K Microphone Power Supply Model No. 2804								15336-32	15336-63	
B&K Preamplifier Model No. 2639								14478-42	14966-41	
B&K Microphone Model No. 4149								25158-89	41569	
Sensitivity @ 250 Hz (mV/Pa)	11.07	12.5	12.31	11.36	11.25	13	10.7	.996 @ 251.2 Hz	3.61	
Calibration voltage	600mV	1200mV	600mV	750mV	500mV		600mV			300mV

Table 2-7. Serial numbers for the equipment used at the C-line sensors in the WSMR experiment, August 2007.

Site Location	C1	C2	C4	C8	C12	C15	C31	C125	C500
RION DA-20 4-Channel Digital Data Recorders	1027072-1	1027072-8	1027072-2	1027071-7	1027072-6	1106061-5			
B&K Outdoor Microphone Assembly Unit Model No. 4921	1444346	1395773	628550	1395765	1428109	526587			562557
B&K ½-in. diameter Microphone Model No. 4149	1456754	1456771	1766858	1649059	1456779	1756473			1064813
B&K Microphone Power Supply Model No. 2804							1466048	1466063	
B&K Preamplifier Model No. 2639							1496750	1496585	
B&K Microphone Model No. 4149							2515914	36861	
Sensitivity @ 250 Hz (mV/Pa)	13.72	11.97	11.89	11.9	11.63	11.5	.805 @ 251.2 Hz	3.19	
Calibration voltage	600mV	1200mV	750mV	500mV	600mV	600mV			300mV

Table 2-8. Serial numbers for the equipment used in the WSMR experiment, August 2007.

Equipment	Serial Nos.
B&K ½-in. Microphone Model No. 4149 (Spare equipment)	1264777, 1064831
B&K Pistonphone Model No. 4228	1727315, 1727316, 1504034, 1504033
B&K Power Supply Model No. 2804 (Spare equipment)	555809, 619105, 1466091, 169100, 2424025
Dell Monitor Bar Code	5598B, 5222B, 5310B, 7045C
Yokogawa Oscilloscope Model No. DL750	27CB25900, 27E346826, 91F717002
GRAS ¼-in. Microphone Model No. 40BF	2515896, 2515897, 2515901
Norsonic Calibrator Model No. 1253	30997, 30992, 30994, 30996
B&K Preamplifier	1246187, 1496641, 1496585, 1246193
B&K Preamplifier	638024, 1447846, 1474629
Nicolet Liberty Units (used in other ERDC-CERL's experiment)	IDP0600222, IDP0600227, IDP0600229, IDP0600234, IDP0600217
PCB Piezotronics 377B11 Liberty Microphones*	105666, 105669, 105849, 105850, 105851, 105852, 105853, 105854, 105855, 105856, 105857, 105848, 105858, 106532, 106533, 106534, 106535, 106536, 106537, 106538, 106539, 106540, 106542, 106543, 106544
PCB Piezotronics 426E01 Liberty Preamplifiers*	2925, 2926, 2927, 2928, 2939, 2930, 2931, 2932, 2933, 2934, 2935, 2936, 2937, 2938, 2939, 2940, 2941, 2942, 2943, 2944, 2945, 2946, 2947, 2948, 2949

2.5.2 Instructions for calibration of far-field equipment

1. Check Channel 2 for GPS signal (approx. 7 volts), or flashing green light on Time Code Generator (TCG).
2. Check charge controller for either “Full” or “Charging” light.
3. Remove wind screen from microphone.
4. Remove *ONLY* rain cover from microphone.
5. Remove bird spike.
6. Put protective grid on microphone.
7. Place B&K Pistonphone calibrator Model No. 4228 on microphone.
8. Turn on calibrator.
9. Use multimeter to measure AC mV @ Channel 1 input to RION DA-20 4-Channel Digital Data Recorder. Record voltage daily in notes.
10. Press “Menu” on RION DA-20.
11. Select “Trigger,” press “ENT.”
12. Select “Mode,” press “ENT.”
13. Select “Free,” press “ENT.”
14. Press “Stop.”
15. Press “Rec.”
16. Let run for 20 seconds.
17. Remove Pistonphone.
18. Enunciate clearly into microphone to clearly identify the site, e.g., “Site No. A1,” “Site No. B8,” “Site No. C15,” etc. The site location is clearly marked on the pelican case.
19. Press “Stop.”
20. Replace bird spike, rain cap, and wind screen.
21. Press “Menu.”
22. Select “Trigger,” press “ENT.”
23. Select “Mode,” press “ENT.”
24. Select “Single,” press “ENT.”
25. Confirm RION DA-20 has correct date and time (within a second or so) with atomic watch. Select “Menu,” select “Date and Time.”
26. Press “Stop.”
27. Press “Rec.”
28. Confirm timer is on “Auto” (line above the word “Auto” on the timer).
29. Close and secure box.

2.6 Detailed daily setup procedures

2.6.1 RION DA-20 (far-field acoustic sensors)

The daily setup procedures for the RION DA-20 4-Channel Digital Data were:

1. Press and hold RION power button for a few seconds until unit starts. The unit will power up and test the Compact Flash (CF) card. The unit will then display the Main Screen.
2. The Main Screen shows the level meters for all four channels, the voltage settings for the ranges that are turned “on,” and “off” for the channels not being used. It also shows the frequency range, record time remaining on the CF card, then the number of triggers, power level, and time.
3. On the Main Screen, ensure that Channel 1 range is set to 10V for microphones at 1 and 2 km sites, 3V for microphones at 4 km sites, and 1V at all sites more than 4 km from the blast site. Ensure that Channel 2 range is set to 10V for all distances. To change range settings, press the “Range” button and use the up or down arrows to select the channel that needs to be changed and then press “Enter.” The current range setting will begin to flash, use the up or down arrow to set desired range and press “Enter” to save the change. Press “Range” button again to remove cursor.
4. **Menu Settings** – press “Menu” button to get to the menu list.
 - a. **Input** – use the up and down arrows to highlight “Input” and press “Enter.” Channels 1 and 2 should be set to “AC.” To change an input setting, highlight the channel and press “Enter.” A list of possible settings will appear. Highlight the setting needed and press “Enter.” Use the same method to set Channels 3 and 4 to “off.” **HPF** – high pass filter and **LPF** – low pass filter should be set to “off” for all four channels. Press “Menu” to return to the menu list.
5. **Record Parameters.** Using the same method as above, set the record parameters as follows:
 - Frequency Range: 5 kHz
 - Sample Frequency: X2.56
 - Rec. Time: Manual
 - Pre-Time: 0s
 - Voice: Off (Marker)
 - Press “Menu” to return to the menu list.
- a. **Calibration:** There are no settings in this section that need to be made.

- b. **Trig:** Using the same method to change fields, set the following parameters:
- **Mode:** Set to “Single” for data gathering and set to “Free” for calibration. After calibration, change mode back to “Single.”
 - **Type:** In “Single” mode, this field should be **external** (when set to “Free” for calibration, this field should be blank).
 - **Level:** This should be blank.
 - **Channel:** This should be blank.
 - **System:** Set parameters as follows:
 - **Play:** BNC OFF.
 - **LCD Contrast:** Set as necessary to view display.
 - **Card Format:** SELECTING THIS FIELD AND PRESSING “Enter” WILL DELETE ALL DATA ON CF CARD.
 - **Save Settings:** Selecting this field and pressing “Enter” will save a copy of the setup on the CF card. Save the setup only after all menu settings are complete.
 - **Light Auto Off:** This sets how long the backlight will be on.
 - **Date Time:** Set date and time to atomic watch date and time.
 - **ID:** Set ID number to the same number that is on the weather proof case. Numbers only (no letters) are allowed in this field. The cases are **numbered** 1-19.

Note that, as shown in Figure 2-6, the record indicator in the display should be on, and not flashing (1). The Trig indicator in the display should be flashing, indicating the unit is waiting for the external trigger (2). Channel 1 voltage should be set according to the distance you are from ground zero (see chart below). Channel 2 voltage should always display 10 volts (3). Channels 3 and 4 should be off. The number of triggers that have occurred should be 0 (4). The display should show 11 hours and a few minutes of record time remaining (5). The record light should not be flashing (6). The index number in the upper right hand corner of the display indicates the file number (7). This should read 1 before the calibration and 2 after the calibration file is saved. The input frequency (8) should always read 5 kHz.

When the RION is ready to start collecting data, the main display of the unit should resemble that shown in Figure 2-6.

Figure 2-6. A RION unit that has been properly setup and is ready to begin collecting data.



2.6.2 Vaisala tethered weather balloons

The setup and operations checklist used in the experiment for the tethered weather balloons (AIR TMT TS5A-ver 4.1) was:

2.6.2.1 Pre-deployment procedures

- 110VAC at the site? (If generated or from inverter, need 20Amp current.)
- 110VAC cord long enough to reach TMT Personal Computer (PC), Receiver, and winch?
- Tarp for the ground to protect a balloon during launch/retrieval or Inflation Shelter prepared if local launch?
- Patch kit for balloon?
- Helium tanks (1.5 per balloon inflation?).
- Wrench for helium regulator?
- Helium regulator, tubing, on-off valve? (extra tubing and tools if tubing splits?).
- Thick rubber bands and string to tie off balloon?
- Dark cloth or other block to shelter laptop screen from bright sun?
- Sufficient 9VDC batteries tested for voltage > 9VDC?

- Voltmeter to check batteries at site?
- Antenna mount on truck or tripod?
- Tie-down or weights for winch assembly?
- 2 x 4-in. 6-ft or longer to hold down balloon fins during inflation and deflation?
- Clean-up files on PC? Extra floppies for PC?
- PC with 110VAC cord, antenna cable, and both receiver cables?
- Winch with manual wrench? Motor checked?
- Sufficient sondes with balanced tails?
- Each sonde pre-checked for frequency? (Use Spectrum Scan option in software—see documentation.)
- Extra cups for sondes?
- Extra 1A 250V slow blow fuses for Receiver?
- AIR TMT manual? Review?
- Sufficient gas in truck?
- Sling psychrometer? Water? Calculator?
- Hand-held AIR barometer or aneroid barometer?
- Clipboard? Paper? Pencils? Test support plan?
- Mul-T-Flares for night operations? Banners for daytime operations?
- Inspect balloon for damage? Bring second balloon?
- Plan for data levels—static sonde levels or variable?
- Coordination with Range Control and FAA?
- Precipitation Probabilities during flight? (Sondes cannot get wet!! \$1000 boards will short out.)
- Wind speed forecasts? (Sondes are very hard to launch in speeds over 15mph.)

2.6.2.2 On-site setup procedures

2.6.2.2.1 Winch setup, including safety issues

- Locate winch at launch site free from obstructions downwind of site.
- Raise tether guide, LOCK it, set speed control to ZERO.
- Set off/on toggle OFF before plugging to 110VAC cord.
- Set off/on toggle to ON. Set up/down toggle to UP. Grab tether balloon harness hook and pull while GRADUALLY turning speed control up. After

about 6 ft of tether unwinds, turn speed control down to zero.

- Set up/down toggle to DOWN, keep tether taut while GRADUALLY turning speed control up. Test EMERGENCY Button to see if it stops the rewind. DO NOT REWIND TETHER HOOK TIGHT AGAINST TETHER GUIDE!!
- If winch motor fails, use manual wrench through covered hole in winch casing. Be prepared to wind for a long time!

2.6.2.2.2 Balloon inflation

- Set up helium tanks with regulator, valve, and hose.
- Lay out tarp on ground or arrange Inflation Shelter to avoid sharp objects touching balloon.
- Lay balloon on ground or Inflation Shelter floor pointing into the wind.
- Open fins on tail with balloon body in between two pairs of fins. If outside, hold down fins with 2x4-in. lumber.
- Attach winch tether to balloon harness coupler.
- Inflate balloon through the nose tube CAREFULLY (costs \$1200) until tail section begins to fill. Too fast injection of Helium can damage the balloon fabric. Periodically stop inflation and listen for leaks. Use patching tape if necessary.
- Continue inflation until the grey/blue tape on the balloon sides is no longer loose-fitting. Tie balloon inflation tube off by rolling material inward until only a few inches remain outside. Fold over and wrap with rubber band.

2.6.2.2.3 Antenna/receiver/PC setup:

- Fix antenna to truck or tripod.
- Locate PC and Receiver in Inflation Shelter or truck cab or equivalent.
- Connect antenna, receiver, PC to 110VAC source: two cables link receiver and PC—the control line is marked with red tape and its connectors are, too, on the receiver (marked "receiver") and PC. Met data line goes into the receiver connector marked "met" (Figure 2-7).

Figure 2-7. Connection diagram for the tethersonde electronics. Beware: 9-pin control line, marked with red tape, has a short special cable section on the PC end with a very fragile connector that goes into the PC mother board through the side of the PC.

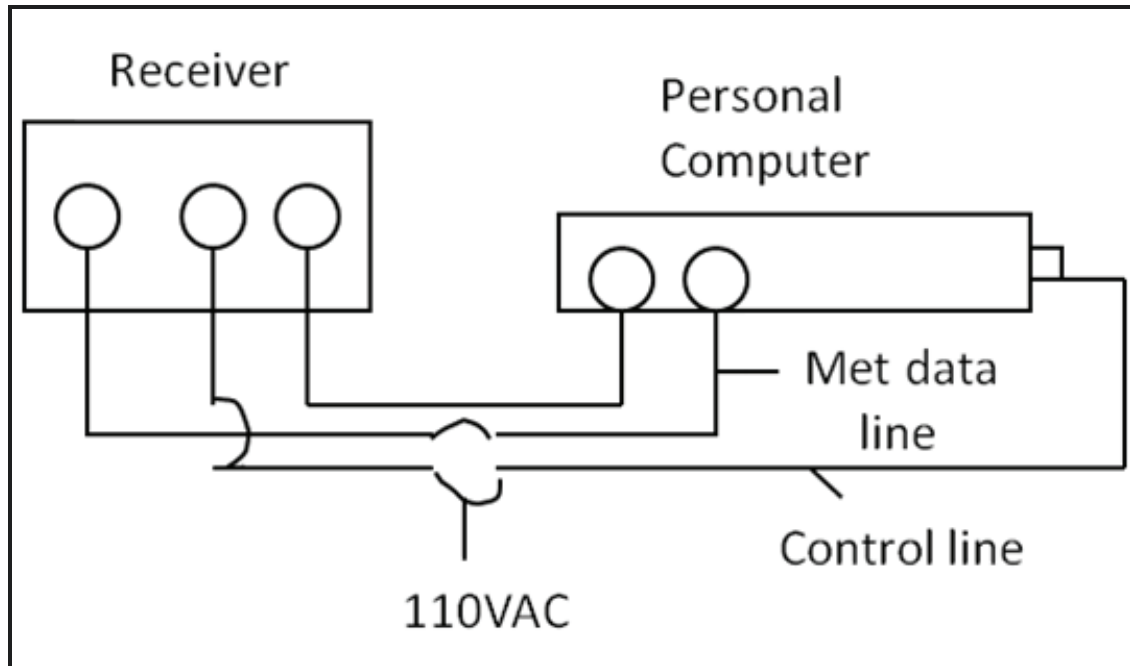

- To check radio environment for interference, use Spectrum Scan selection on MAIN MENU.
- o 1st screen: Use left-right arrow keys to select Port 2. Press F10.
- o 2nd screen: Use up-down arrow keys to select option. For each option, use left-right keys to select frequency value or signal strength. Press F10.
- o A graph of signal strength vs. frequency will appear.
- o To exit graphing, press <ENT>.
- o To return to Main Menu, press F4.

2.6.2.3 On-site launch procedures

2.6.2.3.1 Pre-launch software procedures

- Turn on PC and Receiver.
- MAIN MENU: select "TS5A DATA PROGRAM," <ENT>.
- PROGRAM TITLE screen: press any key other than F2.
- TS4 RECEIVER INITIALIZATION PROCESS screen: (automatic ... executes two cycles of six attempts to

- talk to receiver via COM1 and control line. If successful, disappears after 2-3 seconds. If not successful, reverts to MAIN MENU).
- PTU CARD INITIALIZATION screen: (automatic ... if successful, disappears after 2-3 seconds).
 - SURFACE OBSERVATIONS AND COMMENTS screen: Edit each line via F7, <ENT> with current surface observation at launch location to calibrate not the sondes, but the program's hydrostatic computation of sonde altitude. These data must be updated if they change significantly during the flight. (See next section for "how to.") In NOTES section, put test name, location, time period, date, etc., for data archive. When complete, press F10.
 - NUMBER OF SONDES FOR THIS RUN: type in number, <ENT>.
 - Individual Sonde Edit Boxes:
 - (1) Turn sondes on by ensuring batteries connected and Velcro® straps connected. On/off toggle is "on" when leaning toward outside sonde wall.
 - (2) For first box, type in full serial number "5K-nnnn," <ENT>; "TETHERSONDE CALIBRATION WINDOW" appears before you get a chance to type in sonde's frequency. You get option to accept or reject displayed frequency for the sonde (this "calibration" is only for frequency, not met parameters).
 - (3) For first box after frequency is accepted, FILE DATA ACQUISITION FOR SONDE 'n' screen appears for 2-3 seconds while frequency calibration file is read into program.
 - (4) For first box, press F6 to do preflight for a "ground check" of met parameters like we do with the DIGICORA sondes. The TETHERSONDE INITIALIZATION ERROR message box appears trying to encourage you not to do a preflight so type in "N". Next the TETHERSONDE PREPARATION MODE" screen appears, again trying to get you not to do a preflight so again type in "N". Finally, a real-time display of pressure, temperature, humidity appears.

- (5) For first box, turn sonde Off, then On so it will tell the receiver its pressure coefficients. Edit pressure, temperature, relative humidity via F7 as necessary and enter each edit with <ENT>, not F10. When done with all edits for this first sonde, accept them with F10.
- (6) Repeat steps (2)-(5) for each box corresponding to each sonde being used and write down sequence of sondes with their serial numbers starting with Box #1.
- (7) When done with Sonde Edit Boxes window, accept with F10.
- (8) A PROGRAM PROGRESS screen automatically appears for 2-3 seconds, then the real-time data acquisition window appears.
- (9) Ensure each sonde is functioning properly from real-time data acquisition display.

2.6.2.3.2 Launch procedures

- If night-time run, attach Mul-T-Flare to balloon harness assembly.
- Unwind tether to raise balloon and attach first sonde approximately 30m below balloon harness assembly to avoid sudden changes in the balloon direction from effecting the top sonde.
- Unwind tether further to raise balloon and attach sondes in the same sequence as the Sonde Edit Boxes sequence and at height separation planned on.
- If night-time run, attach second Mul-T-Flare lower down on tether.
- Notify Range Control of balloon launch and final altitude.
- On software, real-time data monitoring screen, go to VIEW, then CLEAR ALL BUFFERS, and restart data and elapsed time. Go to FILE, then START ARCHIVE (go to FILENAME if you do not want default file naming convention (C:\TMTDATA\mmdhmm.DAT)).
- On software, real-time data monitoring screen, you can opt to go to GRAPHICS to see graphs of various met parameters vs. elapsed time or, for variable sonde heights, met parameters vs. height.

2.6.2.4 On-site flight monitoring procedures

2.6.2.4.1 Battery strength

- Always monitor batteries' voltages and correlate to data gaps.
- If a sonde's "dies," disable its data acquisition by going to VIEW, then Disable Sonde (cannot re-enable until retrieval of sonde and preflight again with off/on sequence).

2.6.2.4.2 Surface observation changes

- If p, T, RH change significantly, a new observation must be entered to keep the hydrostatic altitude calculation correct:
 - (1) Go to OPTIONS, then Surface Observations, SURFACE OBSERVATIONS AND COMMENT screen re-appears from earlier pre-launch software procedures.
 - (2) Use F7,<ENT> to re-edit each line as in pre-launch. When done, press F10.
 - (3) WARNING: REINITIALIZE BUFFERS AND CLOCK? screen appears. Reinitialize Buffers option will install the observations in the altitude calculations beginning with new data. At this point you may want to turn the data archiving off (FILE, Stop Archive), reinitialize with new surface observations, turn data archiving back on (FILE, Start Archive). Cancel Reinitialize Command will not apply the new surface data to altitude calculations.

2.6.2.4.3 Mid-flight battery replacement procedures

- Turn off data archiving? (This is your choice To do it, go to FILE, then Stop Archive.)
- In proper order by serial number assignments to specific data levels, winch down, turn off sonde, dismount from tether, disconnect batteries, set aside carefully. Repeat for each sonde.
- In proper order by serial number, connect battery, turn on sonde, remount each sonde to tether, winch upward enough to properly space

next sonde on tether according to data level plan.

- Turn on archiving if it was turned off. (Go to FILE, Start Archive.)

2.6.2.5 Retrieval and dismantling

2.6.2.5.1 Sonde recovery

- Turn off data archiving? (This is your choice. To do it, go to FILE, then Stop Archive.)
- For each sonde, winch down, turn off sonde, dismount from tether, disconnect batteries, pack for transport.

2.6.2.5.2 Balloon recovery

- Disconnect and pack Mul-T-Flare.
- Move balloon over tarp, pointing into wind or move it into an Inflation Shelter.
- Remove rubber band and/or string from inflation tube on the nose of balloon, roll material back into a doughnut ring around hole, and keep it clear to deflate.
- Hold balloon by tail and let the nose rise to aid deflation.
- Pull fin rods from rod holder at tail. Lay two fins to one side and two to the other side. Pull balloon between two pairs of tails.
- After total deflation, pack balloon into plastic pouch and insert into cardboard package.

2.6.2.5.3 Support equipment recovery

- Retract tether into winch ... BE CAREFUL not to retract too far so that connector gets jammed in tether guide. Be sure speed control knob is in zero position.
- Turn on/off switch off. Unplug winch. Lower tether guide. Pack 110VAC cord and speed control knob cable.
- Disconnect PC, antenna, receiver and pack all THREE cables, making sure little cable with delicate connector of the control line is included.
- Pack all extension cords, surface observation equipment.
- Load helium tanks, regulator, hose(s) for transport.

2.6.2.5.4 Post-deployment procedures

- All equipment positioned in assigned assembly area for next flight?
- All equipment checked in Equipment Inventory?
- Each malfunctioning item reported to ETs ?
- Data files passed to meteorologists for analysis?

2.7 Sampling schedule

The initial experimental design planned for a 14-day experiment in which there would be 5 days with 11-hour data sessions from 1300-2400 hours, followed by one or two days of rest, and then followed by another 5 days of 11-hour data sessions from 2400-1100 hours. A buffer of 3 contingency days was planned for weather or schedule delays. The test plan anticipated up to 8 days would be needed before the experiment to set up the instrumentation and 3 days would be required to remove the instruments from the field.

However, it was determined that 11-hour data sessions were too long with respect to a human endurance standpoint, considering the additional time needed for testing the equipment prior to, and after the end of, each data session. Thus, the actual blasting schedule for the first WSMR experiment was:

- 11 Aug 07: 1300-2300 hours (10 hours)
- 12 Aug 07: 1300-2100 hours (8 hours)
- 13 Aug 07: 1300-2100 hours (8 hours)

- 14 Aug 07: 2100-0600 hours (9 hours)
- 15 Aug 07: 2100-0600 hours (9 hours)
- 16 Aug 07: 2100-0600 hours (9 hours)

- 17 Aug 07: Day off

- 18 Aug 07: 0500-1400 hours (9 hours)
- 19 Aug 07: 0500-1400 hours (9 hours)
- 20 Aug 07: 0400-0900 hours (5 hours)

Figure 2-8. Example shot time log.

Shot Time Log

Name BRUCE Date 8/15/07 Start Time 2:00 End Time 0600

Shot Number	Shot Time	Charge Type	Charge Weight	Notes
1	108 21:00:01	C4	1.35	File # 0036 MISSED RECORDING 1ST BLAST
2	109 21:30:01		1.35	0036 0036 ch 3 looks funny Ch 6 NOT REPORTIN
3	110 21:40:01		1.35	0037 ch 6 not reporting
4	111 22:00:01		1.35	0038
5	112 22:20:02		1.35	0039 note long neg. phase of Chan. 11
6	113 22:40:01		1.35	0040 possibly bad mic?
7	114 23:00:02		1.3	0041
8	115 23:20:02		1.3	0042
9	116 23:40:01		1.3	0043
10	117 00:00:01		1.3	0044
11	118 00:20:02		1.3	0045
12	119 00:40:01		1.3	0046
13	120 01:00:01		1.3	0047
14	121 01:20:01		1.3	0048
15	122 01:40:01		1.3	0049 0049
16	123 02:00:01		1.3	0050
17	124 02:20:01		1.3	0051
18	125 02:40:01		1.3	0052
19	126 03:00:01		1.3	0053
20	127 03:20:01		1.3	0054
21	128 03:40:01		1.3	0055
22	129 04:00:01		1.3	0056
23	130 04:20:02		1.3	0057
24	131 04:40:01		1.3	0058
25	132 05:00:01		1.3	0059
26	133 05:20:01		1.3	0060
27	134 05:40:01		1.3	0061
28	135 06:00:01		1.3	0062
29				
30				
31	END OF TEST DAY			
32				
33				
34				
35				
36				
37				
38				
39				
40				

BGC has neg phase @ ~ 1. sec

3 Second Field Session: WSMR, January 2008

In an attempt to isolate the effects of weather on blast sound propagation, the second field experiment at WSMR, conducted in January 2008, was similar to the first experiment conducted in August 2007. However, there were a few differences regarding the blast sound schedule and sensor locations. The second experiment consisted of 12 test days with a reduction in the duration of each data session to 6 hours. To obtain blast data diurnally, four different time sessions were conducted. The first 6-hour data session was conducted for 3 days and then the data session was rotated for the next 6-hour period for the next 3 days. After the first 6 days of testing, a day off was taken before the next rotation of a 6-hour data session was begun and continued for 3 days. The Martin Luther King, Jr. holiday and an extra day were taken off before the rotation to the final 6-hour data session was conducted on the final 3 days of testing.

Other changes between the first and second WSMR experiments include the addition of a second meteorological profiler, relocation of some instrumentation sites, and tethered sonde data sessions that started and ended with the 6-hour blasting session. The research team also added a weather tower near ground zero where the detonations took place. The number of sensors at distances of less than 1 km was reduced by nine sensors: three blast gauges at the 4m distance, three sensors at the 31m distance, and three sensors at the 125m distance.

3.1 Experimental layout and details

Table 3-1 lists the instrumentation layout for the sound sampling equipment and the meteorological sampling equipment. The locations can be referenced to those in the August 2007 WSMR experiment (Figure 2-1, Table 2-1). Table 3-2 lists the serial numbers for the equipment at 125m, and Table 3-3 lists the weather tower details. All other equipment was the same as those in the August 2007 experiment (Tables 2-5–2-8). In addition, the calibration procedures, acoustic equipment setup procedures, and tethered sonde procedures were identical to those used in the August 2007 experiment discussed above.

Table 3-1. Sensor locations and equipment details for all acoustic and meteorological sensors used at WSMR in January 2008.

Site #	Azimuth	Range (m)	UTM Coordinates, Zone 13S (m)			Notes
	(Ref. Source Location)		Easting	Northing	Elevation	
G-0	0.0	0	352240	3723172	1428	Source, h = 3m
BG-A	68.0	4	N/R	N/R	1427	Note 3
BG-B	208.0	4	N/R	N/R	1427	Note 3
BG-C	288.0	4	N/R	N/R	1427	Note 3
A125	68.0	125	352356	3723219	1428	Note 2
B125	208.0	125	352181	3723062	1428	Note 2
C125	288.0	125	352121	3723211	1428	Note 2
A1	68.0	1,000	353167	3723547	1430	Note 1
A2	68.3	2,000	354098	3723913	1432	Note 1
A4	69.0	4,000	355975	3724605	1430	Note 1
A8	68.8	8,000	359697	3726070	1443	Note 1
A12	68.8	12,221	363636	3727586	1511	Note 1
B1	211.3	1,000	351720	3722318	1427	Note 1
B2	202.0	2,000	351492	3721317	1426	Note 1
B4	207.9	4,000	350368	3719637	1427	Note 1
B8	211.3	8,000	348086	3716335	1428	Note 1
B12	208.7	12,000	346485	3712642	1425	Note 1
B16	208.4	16,000	344636	3709094	1427	Note 1
C1	285.8	1,000	351278	3723444	1428	Note 1
C2	286.7	2,000	350324	3723746	1428	Note 1
C4	293.3	4,000	348567	3724757	1427	Note 1
C8	290.0	8,000	344721	3725905	1441	Note 1
C12	286.1	12,008	340705	3726509	1447	Note 1
C15	288.9	15,265	337800	3728122	1452	Note 1
G0-T	127.9	524	352654	3722850		Note 4
G0-WT	259.4	135	352107	3723147		Note 5
A924	69.8	2,985	355042	3724202	1434	Note 6
A924WT	68.4	2,857	354897	3724223	1434	Note 5
B10-T	205.0	9,540	348210	3714525		Note 4
B7-WT	210.6	6,881	348733	3717252		Note 5
C3.5-924	297.2	3,522	349108	3724783	1436	Note 6
C3.5-WT	298.8	3,499	349175	3724859		Note 5
STR#12	346.1	20,601	347293	3743170	1487	Note 7
GRJ#8	301.2	8,687	344809	3727671	1453	Note 7
GAP#6	129.1	17,417	365760	3712192	1633	Note 7
DUQ#19	100.7	10,828	362880	3721164	1499	Note 7

Note 1. B&K 4921 outdoor microphone 1/2-in., 1.5 m height on tripod, Rion recorder (ERDC).
Note 2. 1/4-in. microphone, 1.5 m tripod, Yokagawa recorder (ERDC).
Note 3. Blast gauge, h = 3 m (WSMR).
Note 4. Tethersonde (1 ERDC, 1 WSMR) and met ground station (ERDC).
Note 5. 15 m weather data tower (ERDC), 8 guy wires on 25 ft and 50 ft radius circle, stakes up to 2 ft deep.
Note 6. 924 MHz atmospheric profiler (WSMR).
Note 7. SAMS Site (WSMR).

Table 3-2. Model and serial numbers for the 125m microphone locations, WSMR Experiment #2, January 2008.

Equipment	Site Location No. A-125		Site Location No. B-125		Site Location No. C-125	
	Model #	Serial #	Model #	Serial #	Model #	Serial #
Microphone power supply B&K	2804	1533634	2804	555809	2804	2424025
Preamplifier B&K	2639	1527834	2639	1496750	2639	1442842
½-in. B&K microphone cartridge	4149	41572	4149	41577	4149	41574

Table 3-3. Serial numbers for the sensors used on the four weather towers G0, A-WT, B-WT, and C-WT. Equipment manufacturer: Onset Computer Corp; Model: HOBO Weather Station.

Site No. G0-WT	Serial #		
Loggers	1221389	1190890	
Barometric pressure	718075		
Solar rad.	732721		
Soil moisture	1219683		
Rain gauge	668178		
	Anemometer Serial #	Temp. 12 bit Serial #	Temp, 8 bit Serial #
1 meter		732759	
3 meters	1109570	1206039	597215
6 meters	1166507	1206041	
10 meters	1224550	1206136	1224525
15 meters	1224547	1206134	
Site No. A-WT	Serial #		
Loggers	725908	724625	
Barometric pressure	718076		
Solar rad.	730730		
Soil moisture	986131		
Rain gauge	668179		
	Anemometer Serial #	Temp. 12 bit Serial #	Temp, 8 bit Serial #
1 meter		732770	
3 meters	991684	732773	725372
6 meters	716311	1000055	
10 meters	713657	732766	725363
15 meters	713662	1175142	
Site No. B-WT	Serial #		
Loggers	724611	724619	724611
Barometric pressure	718073		718073
Solar rad.	730732		730732
Soil moisture	1001459		1001459
Rain gauge	668172		668172

	Anemometer Serial #	Temp. 12 bit Serial #	Temp, 8 bit Serial #
1 meter		732772	
3 meters	713665	732771	725365
6 meters	713658	732761	
10 meters	716310	732767	725357
15 meters	981368	1175143	
Site No. C-WT	Serial #		
Loggers	550714	724627	550714
Barometric pressure	718074		718074
Solar rad.	730735		730735
Soil moisture	1001458		1001458
Rain gauge	668170		668170
	Anemometer Serial #	Temp. 12 bit Serial #	Temp, 8 bit Serial #
1 meter		732769	
3 meters	981383	732765	725373
6 meters	991685	732760	
10 meters	713666	732763	725385
15 meters	965682	1175145	

3.2 Sampling schedule

The blasting schedule for the January 2008 WSMR experiment was:

- 11 Jan 08: 1200-1800 hours (6 hours)
- 12 Jan 08: 1200-1800 hours (6 hours)
- 13 Jan 08: 1200-1800 hours (6 hours)

- 14 Jan 08: 1800-0000 hours (6 hours)
- 15 Jan 08: 1800-0000 hours (6 hours)
- 16 Jan 08: 1800-0000 hours (6 hours)

- 17 Jan 08: Day off

- 18 Jan 08: 0000-0600 hours (6 hours)
- 19 Jan 08: 0000-0600 hours (6 hours)
- 20 Jan 08: 0000-0600 hours (6 hours)

- 21 Jan 08: Martin Luther King, Jr. holiday
- 22 Jan 08: Day off

- 23 Jan 08: 0600-1200 hours (6 hours)
- 24 Jan 08: 0600-1200 hours (6 hours)
- 25 Jan 08: 0600-1200 hours (6 hours)

4 Third Field Session: FLW, August 2008

4.1 Experimental layout and equipment details

The layout for the experiment at FLW was similar to those at WSMR, and consisted of sound measurement sites along three lines (i.e., A, B, and C lines) approximately equally spaced azimuths from the blast site. Sensors were placed at distances of 4m, 125 m, and 1, 2, 4, 8, 12, and 16 km, as feasible. For FLW, all of these distances were either on-post or in off-post rural areas for the B and C lines. For the distances along the A-line, the 16km site was in the center of a downtown area and therefore, the site at 14 km (which was on the installation boundary) was the furthest distance used. Figure 4-1 shows the locations for each sensor used in the experiment (also listed in Table 4-1).

Figure 4-1. The far-field locations of the equipment for the equipment at FLW. The locations of the equipment were the same for both experiments at this location (August 2008 and March 2009).

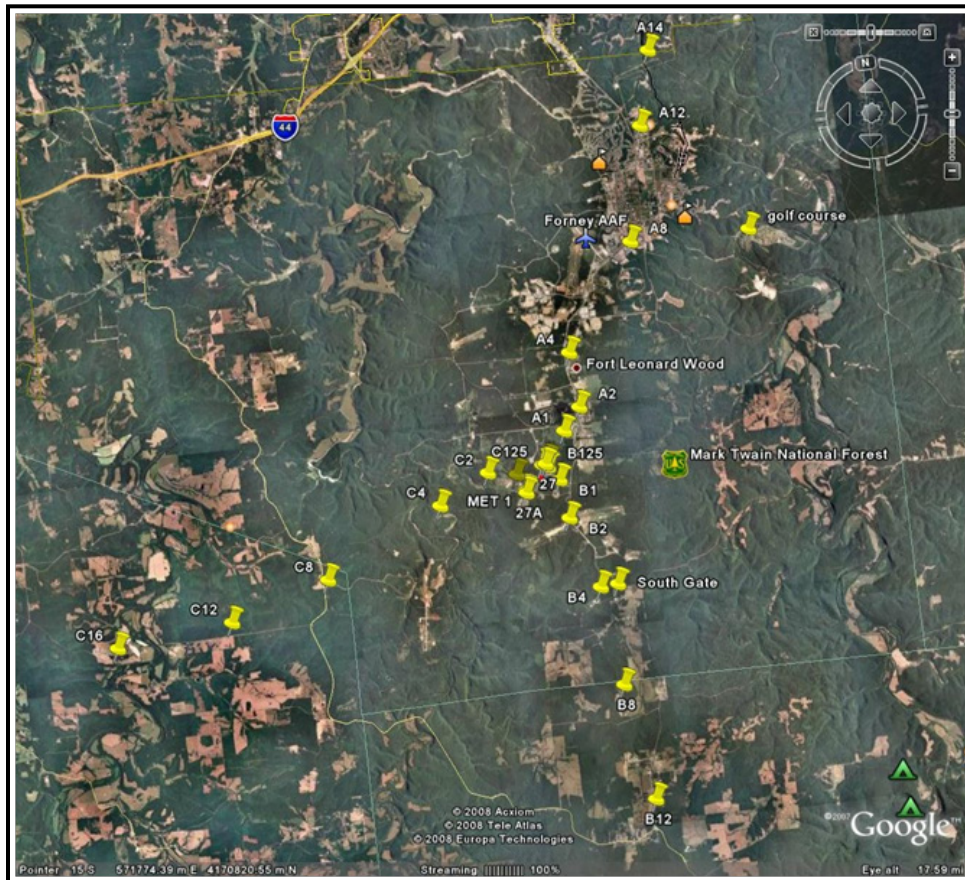

Table 4-1. Coordinates for the sensors used in the August 2008 and March 2009 experiments at FLW.

Site	Easting	Northing
G0	573264	4169543
A1	574063	4170524
A2	574703	4171289
A4	574522	4173200
A8	577063	4176740
A12	577926	4180583
A14	578451	4183197
B1	574028	4168931
B2	574204	4167772
B4	574670	4165157
B8	575025	4162028
B12	575688	4157373
B16	576882	4154107
C1	572257	4169291
C2	571268	4169451
C4	569744	4168630
C8	565465	4166712
C12	561741	4165220
C16	558096	4164927
G0-WT	573256	4169424
A-WT	575676	4175666
B-WT	574993	4162043
C-WT	568064	4166770
Tethersonde 1	572385	4168574
Tethersonde 2	574687	4165110

Tables 4-2–4-4 list the serial numbers for the equipment at used for this experiment. The weather tower equipment was identical to that listed in Table 3-3. Also, the calibration procedures, acoustic equipment setup procedures, and tethersonde procedures were identical to those used previously.

Table 4-2. Specifications for the calibrators used at the FLW experiment in August 2008.

Calibrator	Norsonic Model #	Norsonic Model #	Norsonic Model #	Norsonic Model #
A-line	1253	30993	114	1100
B-line (on-post)	1253	30997	114	1100
C-line (on-post)	1253	30997	114	1100
B-line (off-post)	1253	30994	114	1100
C-line (off-post)	1253	30994	114	1100
Near-field (< 1km)	1253	30996	114	1100
Spare	1253	30995	114	1100

Table 4-3. Model and serial numbers for the 125m microphone locations, FLW experiment, August 2008.

Equipment	Site Location No. A-125		Site Location No. B-125		Site Location No. C-125	
	Model #	Serial #	Model #	Serial #	Model #	Serial #
B&K power supply	2804	1466054	2804	2424025	2804	1466060
B&K preamp	2639	1447823	2639	1527832	2639	1496585
GRAS ¼-in. Microphone	40BF	48592	40BF	41577	40BF	41574S

Table 4-4. Serial numbers for the RION DA-20 4-Channel Digital Data Recorders used at each site in the August 2008 FLW experiment.

Site Location	Serial #
A1	11060617
A2	11060616
A4	10270723
A8	10270720
A12	10270729
A14	10770848
B1	11060619
B2	11060618
B4	10270727
B8	10270718
B12	10270725
B16	10270715
C1	10270721
C2	10270728
C4	10270722
C8	10270717
C12	10270719
C16	11060615
Spare	10270726
Spare	10270724
Spare	10770847
Spare	10770849

4.2 Sampling schedule

The schedule of events sampled a wide range of propagation (meteorological) conditions. There were 12, 6-hour sessions that occurred for a total of 72 hours. There were 12 firing “days” (which included night firing). The total duration of the testing operation was approximately 24 days, including setup and breakdown and packing of the equipment.

The blasting schedule for the FLW third field session was:

- 18 Aug 08: 1200-1800 hours (6 hours).
- 19 Aug 08: 1200-1800 hours (6 hours).
- 20 Aug 08: 1200-1800 hours (6 hours).

- 21 Aug 08: 1800-0000 hours (6 hours).
- 22 Aug 08: 1800-0000 hours (6 hours).
- 23 Aug 08: 1800-0000 hours (6 hours).

- 24 Aug 08: Day off.

- 25 Aug 08: 0000-0600 hours (6 hours).
- 26 Aug 08: Rain day—incurred approximately 3 in. of rain rendering it impossible to conduct tests. Rather than change the demolition crew’s schedule and reschedule the remainder of the range time, it was decided to eliminate this day of testing.
- 27 Aug 08: 0000-0600 hours (6 hours).

- 28 Aug-1 Sept: Days off—the extended days off were due to the effects of Hurricane Ike and the Labor Day holiday.

- 2 Sept 08: 0600-1200 hours (6 hours)
- 3 Sept 08: 0600-1200 hours (6 hours)
- 4 Sept 08: 0600-1200 hours (6 hours)

5 Fourth Field Session: FLW, March 2009

5.1 Experimental layout and equipment details

The microphone positions for this field experiment were the same as those in the August 2008 experiment at FLW. This enabled the ability to better isolate the effects of the weather on the blast sound propagation. The model and serial numbers for the calibrators and RION recorders used in this experiment were identical to those in the August 2008 experiment (Tables 4-2 and 4-4). Table 5-1 lists equipment details for the microphones at 125m.

The serial numbers of the equipment used on the weather tower in this experiment were identical to those of the WSMR 2008 and FLW 2008, with the exception of two pieces of equipment on the C-WT weather tower, the 12-bit temperature sensor at the 6m height (Serial #1206040) and the 8-bit temperature sensor at the 10m height (Serial #725358).

Table 5-1. Model and serial numbers for the 125m microphone locations, FLW experiment, March 2008.

Equipment	Site Location No. A-125		Site Location No. B-125		Site Location No. C-125	
	Model #	Serial #	Model #	Serial #	Model #	Serial #
B&K power supply	2804	2424025	2804	1466023	2804	1466052
GRAS preamp	26AB	50121	26AB	50122	26AB	50114
GRAS ¼-in. Microphone	40BF	41578	40BF	35979	40BF	35968

5.2 Sampling schedule

The blasting schedule for the FLW fourth field session was:

- 9 Mar 09: 1200-1800 (6 hours).
- 10 Mar 09: 1200-1240 (Equipment problems led to a shortened blast schedule).
- 11 Mar 09: 1200-1800 (6 hours).
- 12 Mar 09: 1800-0000 (6 hours).
- 13 Mar 09: 1800-0000 (6 hours).
- 14 Mar 09: 1800-0000 (6 hours).
- 15 Mar 09: Day off.
- 16 Mar 09: 0000-0600 (6 hours).
- 17 Mar 09: 0000-0600 (6 hours).
- 18 Mar 09: 0000-0600 (6 hours).
- 19 Mar 09: 0600-1200 (6 hours).
- 20 Mar 09: 0600-1200 (6 hours).
- 21 Mar 09: 0600-1200 (6 hours).

6 Conclusion

This work has detailed the procedures and equipment used to carry out a series of blast noise experiments at White Sands Missile Range, NM and FLW from 2007 to 2009. The experiments yielded a large data set of blast waveforms at distances up to 16km for charge sizes of approximately 1.25 lb, and several examples of blast noise generated by 2.5- and 5-lb charges. In addition, the experiment captured a comprehensive set of meteorological measurements over the duration of the experiments.

The data provided by this large-scale experiment comprise a definitive dataset for the effects of a wide range of meteorological conditions on long-range high-energy blast sound propagation in climate types similar to the majority of CONUS military installations (arid desert and temperate vegetated). It is anticipated that this unique resource for blast acoustics will be used in years to come to guide noise policy and testing/training decisions on-post, as well as contributing to the improvement of noise assessment software.

Acronyms and Abbreviations

Term	Definition
AERTA	Army Environmental Requirements and Technology Assessments
AGL	Above Ground Level
AR	Army Regulation
ASCII	American Standard Code for Information Interchange
CEERD	U.S. Army Corps of Engineers, Engineer Research and Development Center
CERL	Construction Engineering Research Laboratory
CONUS	Continental United States
CRREL	Cold Regions Research and Engineering Laboratory
DC	Direct Current
DoD	U.S. Department of Defense
EQT	Environmental Quality Technology
ERDC	Engineer Research and Development Center
FLW	Fort Leonard Wood, MO
GPS	global positioning system
IRIG	Inter-Range Instrumentation Group
LEQ	Equivalent Average Sound Level
NAPS	Noise Assessment and Prediction System
PC	Personal Computer
PHC	Public Health Command
R&D	Research and Development
SAMS	Surface Automated Measuring System
SEL	Sound Exposure Level
SF	Standard Form
TR	Technical Report
U.S.	United States
USACHPPM	U.S. Army Center for Health Promotion and Preventive Medicine (USACHPPM) (now known as the Public Health Command)
USAPHC	U.S. Army Public Health Command
UTM	Universal Transverse Mercator
WIT	Warhead Impact Target
WSMR	White Sands Missile Range