

**SURVEYING**  
**FOR**  
**BEGINNERS**

---

DAVIS

1911













# SURVEYING

FOR

BEGINNERS

---

J. B. DAVIS

1895-1911

---

SECOND EDITION  
REVISED AND ENLARGED

---

GEORGE WAHR, PUBLISHER  
ANN ARBOR, MICHIGAN  
1911

TA 545  
D4

COPYRIGHT  
BY GEORGE WAHR  
1911

11-29110

---

The Ann Arbor Press

© Cl. A 297900

No. 1

11-29110

LIST OF WORK

- I. Reading Verniers.
- II. Measuring with Steel Tapes.  
Survey of a triangle.  
Measuring the same distance eight times.
- III. Handling Instruments.  
Transit. Line Staff.  
Level.  
Leveling Rod.
- IV. Survey of a triangle with a transit.  
Twenty rod readings on the same B. M.
- V. Reading Angles. Closing the horizon.  
Peg Levels. Short circuit.
- VI. Intersections and Connections.
- VII. Passing Obstructions.
- VIII. Circular Curves with Steel Tapes.
- IX. Circular Curves with Steel Tapes and Transit.
- X. Traverse Survey. Field with seven sides.  
Peg Levels. Long circuit.
- XI. Traverse Survey. Computing and platting.  
Profile Leveling.
- XII. Profile and Grade Line.  
Staking out a grade.
- XIII. Straight Line.  
Staking out a building.





## OUTFIT. NOTICE.

### 1. Outfit required.

For each person:

Reprints and pamphlets.

Direction of a Line.

Recommended.

Leveling and Earthwork.

Field Note Book, Like Sample.

Lead Pencil, Faber, No. 5, red Hexagon.

Eraser, typewriter, small.

Cross ruled paper, for platting.

For each party:

Wire spikes, 6".

12

Wire lath nails, 3d fine.

$\frac{1}{4}$  lb.

Boy's axe, sharp.

Marking crayon.

### 2. Notice.

Once telling is enough.

Parties consist of two, or four, persons, ordinarily.

Time for each duty will be limited.

Shortcomings to be made up outside of class time, and without delay.

Do the work in the order in which it is listed.

Every person must "Figure."

Put all computations in field note book, with notes.

No loose papers allowed.

Do not come here with parts of the notes of a piece of work in different books. Every note book must contain them all.

Present all records, maps, and drawings, until given a grade.

Late comers make up all back work within three weeks, or drop out.

Instruments, apparatus and tools, are issued on the check system. Each one gets five checks for which a charge of fifty cents is made. The money will be returned at the end of the semester upon the return of the checks. A check is left for each article issued. The checks are returned upon the return of the articles in the same condition as when issued.

No playing with tools, or apparatus.

Pay for all losses or breakages.

Report at once, all losses, breakages, or defects, to have them made good in time for the next work.

When a word, or a sign, is not understood, look it up then and there, in a dictionary, or text book, or inquire of a teacher at the next opportunity.

We do not teach what may be read in a book, without aid. Learn how to do things by doing them,—same as baseball is learned. "Practice makes perfect."

Recitations are the examination, except a written examination upon the subjects of the field work.

Review Plane Geometry and Plane Trigonometry.

Surveying is learned by study, by work, and by practice,—not by merely staying 'round where surveyors, books, and instruments are.

"It is better not to know so many things than it is to know so many things that are not so."

"You can find eighteen men who can tell how to do a thing where you can find one who can do it."

—*Josh Billings.*

### 3. Not so.

When you "See it," you know it.

Something will prove useful which is written down carefully and specifically, with order, decorum, and diagrams, in a note-book, and then laid aside and forgotten.

You can "laze" around at the beginning of the semester and make up for it by cramming towards the end.

One can get along here, or elsewhere, as an engineer, without being able to write plainly, make neat figures, and use with facility, some style of plain lettering.

A surveyor can "establish" a landmark or a boundary.

A "true" meridian,—a "magnetic" meridian.

The "declination" of the magnetic needle.

"Printing" a statement in a book *makes* it true.

4. **An engineer should be able to**

Measure distance.

Measure an angle.

Keep notes.

Run a traverse.

Run a straight line.

Take levels.

Make computations.

Make maps and drawings.

Write a report.

Take care of instruments.

Use a needle compass, some.

Lay out a curve.

Oversee equipment.

5. **A survey consists of**

The field work.

The field notes.

The calculations.

The permanent record.

Unless what each of these items implies is completed in a thorough and workmanlike manner, the survey will be imperfect, and usually inadequate. Such surveys commonly prove to be both unsatisfactory and expensive.

6. **The Field Work** comprises many kinds of operations and labor.

I. Running lines, straight or curved, and marking their location with stakes, or otherwise.

2. Measuring distances, with a chain, tape, stadia, or other device.
3. Finding the direction of a line.
4. Measuring angles, with a divided circle, a steel tape, or other means.
5. Placing, and constructing, monuments, such as landmarks and station marks.
6. Getting differences of elevation, or running levels, as it is called.
7. Making bench marks for the levels.
8. Digging for old landmarks.
9. Sounding.
10. Making borings for showing materials.
11. Gauging of streams.
12. Building stations for triangulation.
13. Making astronomical observations.

This list is not exhaustive, only illustrative.

7. **The Field Notes** are made in the field. They are a plain, orderly, neat, and complete, record of the field work, and attendant conditions, circumstances, and facts, made according to the directions below.
  1. Mark name and number of party neatly and plainly, at top right hand side of first outside cover of note-book.
  2. Number leaves of note-book, if not numbered.
  3. Select a brief and comprehensive title. Enter this title at top of every new page to be used for notes.
  4. Enter the date on every page of notes, and at beginning of notes of each day's work.
  5. Note instruments used, and any special tools, or apparatus, on each leaf of note book.
  6. Record the place where work is done.
  7. Write an explanation of the object of the work, if not apparent from the title or the notes themselves.
  8. Write the name, position, and duty, of every person who does any part of the field work.

9. Make a plain, full, complete, orderly, and unmistakable, record of every thing done, every fact ascertained, and the evidence and witnesses therefor. Record what is seen, without alteration, computation, or modification. Set down every act, or fact, at once. Trust nothing whatever to memory.
  10. At the bottom of each page of notes place the signature of the recorder,—also at the end of the record of each day's work.
  11. When the notes of any work are in different parts of the book, write, at the beginning of the record at every place in the book, a reference to the place where the preceding notes ended, and at the end of every record a note of the place where the record is continued. The same applies to records contained in different books.
  12. When the note-book is filled, enter a title on the outside of the front cover, with the dates of beginning and end—the records therein.
  13. Make, and enter, an index in the book, if needed.
8. **The Calculations** are generally made in the office, though many minor ones are made in the field, especially in land and railroad surveying and in staking out works. When made in the field they should be spread on the pages of the field note-book in an orderly manner, as part of the field notes. In any case, if the calculations are relatively brief, they should be entered in the field note book immediately following, or, by cross references, immediately in connection with, the field records and the results made a part of those records. More extensive and elaborate calculations require a system adapted to the work, but, in general, the figures and results should be carefully preserved in a well kept record. What is known in the trade as the Standard Figuring Book may be useful. The page is 9" x 12" cross ruled in  $\frac{1}{4}$ " squares. The calculations must be completed in order to obtain the results and fulfill the purposes for which the survey was made.

9. **The Permanent Record** preserves the results of the previous labors as well as completes the survey. It may consist of only a field note book, suitably reviewed, indexed and marked; or there may be elaborate reports accompanied by fine maps, with detailed plans, and estimates. It all depends upon the kind, extent, and purpose of the survey.

Here should be read Appendix "G" of Johnson's Surveying, this being Professor Raymond's paper on what constitutes a survey.

10. **Maps and Plats** should contain

1. Map, or plat, properly drawn and lettered,—not a scrawl, or fragment.
2. Border.
3. Title.
4. Scale. A linear scale, if to be reproduced.
5. Direction mark. Meridian and azimuth.
6. Explanations, if needed.
7. Party who made the survey.
8. Draftsman's name.
9. Dates. Of Survey. Of map.
10. Designations of stations, land marks, and notable points of survey.
11. Line of reference.
12. Dimensions. All in one unit ordinarily. Distances. Depths. Sizes. Elevations.
13. Angles. Azimuths. Bearings.
14. Names of objects. Such are, rivers, streets, places, land owners, buildings.
15. Sketches. Illustrations.
16. Results. Such are, areas, amounts, quantities, volumes.
17. Authority for making. Often may be part of title.
18. Location; including state, or country; district or county; township, village or city; and name of locality; any, or all, of these, or similar terms, that may be necessary to designate unmistakably the position of the survey on the ground. Often may be included in sub title.



- 19 If on more than one sheet, put on each the whole number of sheets and its own number, thus,—...sheets.  
Sheet No....

The sheets should be made to be read from the bottom and right hand side.

A standard size for sheets should be used on any survey of considerable extent wherever it is practicable to employ such.

Things shown should be given proper relative prominence,—not one of them, as the title, or draftsman's name, overshadowing all the rest. This is the primary requisite of good map making. Consult; good atlases, such as the Century Atlas; U. S. Charts; Reports of U. S. Coast and Geodetic Survey; Maps of U. S. Geological Survey; published drawings; and books for the guidance of draftsmen. Note the breadths of lines used, and measure, and compare, the heights of letters.

Maps and plats should plainly show:

1. What they were made for.
2. What they represent.
3. Where the things represented are.
4. When they were made.
5. Where they were made.
6. Who they were made by.
7. What the authority was for making them, if made by the order of some official, under any Act of Congress, statute, ordinance, or order of court.

11. **Reports** should follow the same general lines as the field notes and maps. Consult the reports of notable surveys, such as that of the Deep Water Ways Commission, or the reports of individual engineers of standing relative to proposed works, as that of Mr. Joseph Ripley, U. S. Ass't Eng'r on the connection of Birmingham, Ala., with the Black Warrior River, by canal, which may be found in the Reports of the Chief of Engineers U. S. A.

## I. READING VERNIERS.

### INFORMATION.

12. A vernier, in general, is a device for indicating certain fractional parts of one of the equal spaces, or divisions of a graduated line. The graduated line may be straight, as on a scale, or leveling rod, or it may be curved, as on the plate of a transit. The vernier itself is a short scale of equal parts, straight or curved to fit the graduated line to which it applies.

See what is the value of a space on the scale, or circle, to which the vernier applies.

Place the vernier so two marks on it match, or are in exact line with, two marks on the scale or circle. Count the spaces on the vernier between these two marks.

Divide the value of a space on the scale, or circle, by this number.

The quotient will be the least reading of the vernier.

13. To read a vernier, see where the zero line, or index, of the vernier points. If this index, or line, matches a line on the scale, or circle, that line on the scale, or circle, will show the reading of the circle, or scale, at once, without the aid of the vernier. If the index of the vernier does not match a line on the scale, or circle, look along the scale, or circle, in the direction in which the reading is to be taken, and note the reading of the scale, or circle, shown by the line next preceding the index of the vernier. Look along the vernier and find a line on it which matches a line on the scale, or circle. Note the number of divisions of the vernier between this line and its index or zero line. Multiply this number by the least reading of the vernier to get that part of the whole reading which is given by the vernier. This multiplication is commonly done un-

consciously by means of the mechanical aids supplied for reading the vernier. Add, or annex, the vernier reading to the scale, or circle, reading, previously noted, to get the full reading, up to the index of the vernier.

When looking for the mark on the vernier which matches a mark on the scale, or circle, observe one or two marks on the vernier each way from the one supposed to match with a mark on the scale, or circle. These marks should mismatch the marks on the scale, or circle, equal amounts, in opposite directions, when at equal distances from the mark which is supposed to match precisely. Thus make sure which mark on the vernier it is that really matches precisely with a mark on the scale, or circle. When no mark on the vernier really matches precisely with a mark on the scale, or circle, the actual reading of the vernier may be obtained to one-half, or even one-third, of its least reading, by observing the marks on the vernier in the manner described.

Useful ways of applying and reading verniers are to be learned by experience.

## I. READING VERNIERS.

### PRACTICE.

#### 14. Directions.

Ascertain and record the least reading of each vernier.

Take and properly record twenty full readings of each.

See Sec. 50 for samples of vernier readings.

Total number of all vernier readings is 180.

Should be taken up in the order in which they are named.

Leveling Rods.

Boston. New York. Troy. Philadelphia.

Short rod and long rod,—ten readings of each.

Railroad Compass, or Transits 1884, or 1885, or the like.

Transit 1382, or 1383, or 1384, or the like.

Plate. Vertical Circle.

Transit 4838, or the like.

Plate. Vertical Circle.

## II. MEASURING WITH STEEL TAPES.

### INFORMATION.

15. A steel tape measuring set includes the articles named below:

A one hundred feet steel tape, with but a few marks on it, and its reel.

Two handles for the one hundred feet steel tape,—split sticks, 3" long, will do.

A fifty feet steel tape, divided to hundredths of a foot, in its case.

Two brass 1 lb. plumb bobs, with strings.

Eleven 6" wire spikes.

An axe.

Line staves may be needed for ranging lines.

Find where the end marks for distance are on both tapes.

This must be done before correct measurement can be made. The ends of the 100 ft. tape often do not indicate its length, there being an extra 1.25 to 1.50 of steel ribbon at each end. The zero of the 50 ft. tape may be found by turning the end of the tape back; matching the 1 ft. mark to some other foot mark on the tape; smoothing out the loose end beside the tape; and noticing on it, exactly where the next foot mark fits, at, or near, the free end.

Keep the steel tapes wound up,—as much of the time as possible, and get the work done.

Wind any steel tape so the figures are within the coils, and with the zero at the free end.

The zero end of a tape goes ahead, when measuring.

The 100 ft. tape is taken off of its reel and a handle slipped on each end of it when marking a tape length. The handle at the forward, or zero end, should not slip off from the tape of itself. The handle at the rear, or 100 ft., end, should slip off very easily, because it should be taken off when the tape is drawn forward.

If the 100 ft. tape has been mended, test the spaces between the marks on it by comparison with a standard, or with corresponding spaces marked by small wire nails in stakes driven in the ground till firm, and having their tops all at nearly the same elevation. The spaces between the wire nails may be laid off with the 50 ft. tape.

Make a table of the correct total distances from the zero of the 100 ft. tape to each of the marks on it. Use this table in recording measurements with this 100 ft. tape.

Two men make the measurements, one at each end of the tape.

Call the one at the zero end the Leader, as he goes ahead, and the other the Follower.

The follower is responsible for the correctness of all measurements.

The leader must watch and aid in every way he can to make correct measurements. Errors are not tolerated.

In following a line both should keep the line by referring its range to some object beyond the other. While measuring, both should be on the watch for other objects on the range of the line, as usually, owing to the lay of the ground, the same object cannot be used to range by for any considerable distance. Both men should know the exact range of the line at all times, if possible. When starting, the follower puts the leader exactly in line, whereupon the leader selects an object on the range and beyond the place the measurement starts from. As they move forward the follower ordinarily directs the leader on to the line as each tape length is marked, but the leader should carefully observe whether, by his own marks, he is on the line, or not.

Before beginning a measurement, the follower counts the spikes, and lays one beside the mark from which the measurement is to proceed. He hands the others to the leader and says "Ten!" The leader counts them and says "Ten!" In this way they make sure of starting with the right number of spikes, and with ten of them in the hands of the leader.

Draw out the tape the full length with the zero end ahead, and about on line.

Leader take the zero end in hand, and put on his handle.

Follower slip his handle on the 100 ft. end, and bring the 100 ft. mark about to the mark to be measured from.

Follower directs leader accurately into line, and shows the leader the mark from which the measurement is to proceed.

Leader takes the range of the line carefully, and finds some object, if possible, on the range beyond the follower. If such an object cannot be found leave a picket just back of the mark to be measured from, set exactly on the range of the line. A picket may be a stick of suitable length.

Leader draws up the tape ready to measure.

Follower holds 100 ft. mark exactly to the mark to be measured from, and directs the leader to hold the zero end of the tape exactly in line.

Leader pulls 15 or 20 lbs. on the tape.

t Follower looks once more at the 100 ft. mark on the tape and sees that it is exactly at the mark to be measured from and that the zero end of the tape is on line.

When both men are satisfied that the conditions are favorable for a trustworthy measurement,—that is, both are “Ready,”—the follower says “Ready,” “Right,” “All right here,” “Mark,” or any useful form of words.

Leader marks the place on the ground even with the zero mark on the tape, being careful not to release the tension, and to keep exactly in line. The mark may be the center of a spike stuck into the ground so as to stand firm, a scratch with the point of a spike, the point of a spike, carefully placed, or any other suitable mark.

Leader leave a spike at this mark.

Test the measurement by one or more trials after the mark at the zero end of the tape is made, until satisfied that the mark is correct for both distance and line.

Follower slips off his handle quickly, letting go the rear end of the tape, and picks up the spike at the mark from which the measurement proceeds.



Leader draws the tape forward 100 ft. on the line.

Follower advances to the spike left by the leader where he arrives about the time 90 ft. of the tape have passed the spike. He picks up the tape, lets it run through his hands till the 100 ft. end is almost in hand, when he calls "Hold," or "Halt," to the leader, and quickly slips on his handle.

Leader stops, and the tape is placed about on line.

Follower holds the 100 ft. mark to the spike and the operations for marking the first tape length are repeated till both are satisfied the work is correct.

Follower slips off his handle, takes up the spike where he is, and they proceed as before.

Thus continue until the leader has put down five spikes.

While going forward to place the sixth spike the follower counts the spikes he has and calls "Five" to the leader, who counts those he has and answers "Five." They thus verify the count without delay. Leave a mark in place of the fifth spike.

Unless each has "Five," review the work and correct the errors.

Continue the measurement as before until the leader has put down his last spike. He calls "Out" to the follower, and stands by the last spike.

Follower slips off his handle, takes up the spike where he is, and goes forward, counting the spikes he has. He hands them to the leader and says "Ten."

Leader counts the spikes given him and says "Ten."

Here the count is verified and any errors found must be corrected. For this purpose the mark left in place of the fifth spike will make it necessary to remeasure but five tape lengths instead of ten, or more.

The eleventh spike keeps the measurement while the spikes change hands, the count is verified, and errors found and corrected. The measurement proceeds from the eleventh spike and the follower takes it up only after the spike next beyond it is set,—the same as he took up the spike at the starting mark.

Record the "Tally" of ten tape lengths.

So continue until a spike is set less than 50 ft. from the mark the measurement proceeds to. This spike may come before reaching that mark or beyond it.

Follower slip off his handle, take up the spike where he is, count the spikes he then has, and call the number,—as “Three,”—to the leader.

Leader count the spikes he has and answer with the number,—as “Seven.”

Each retain the spikes he has and leave the one last set in the ground.

The sum of the numbers each has must be ten. If not, review the work and correct the errors.

The spikes the follower has show the number of tape lengths the last spike set is past tally mark, or from the place where the measurement began if less than ten tape lengths away.

Measure from the spike last set to the mark the measurement proceeds to, using the 50 ft. tape. Leader take the zero end of it and follower read the tape. Wind up this tape. Record the total number of tape lengths, or hundreds of feet, as shown by the number of tallies passed and the number of spikes the follower has.

Record the measurement made with the 50 ft. tape.

Add the latter to the former, or subtract it therefrom, on the page of the note book, and make a record of the distance between the two marks the measurement was made to obtain.

Follower take up the eleventh spike.

Follower take all the spikes, count them, place one at the mark measured to, give the others to the leader and say “Ten.”

Both must agree as to the count.

Proceed with the measurement of the next line as the first was measured.

Thus continue the work, at will.

Stand at the side of a steel tape to get distance, to read the tape, or to hold a mark on it even with another mark.

Stand on, or look along, a line, to give, or get, line.

16. All measurements must be level. Hold the two ends of the tape at the same elevation. Use the plumb bob to mark the point on the ground even with the mark on the tape. Measure down sloping ground if the descent is more than two per cent, on the best work. If the slope is too steep for the easy use of the whole tape, use it by parts, as directed below. Where there are several slopes along a line, descending in opposite directions, begin at the top of each and let the separate measurements meet in the depressions, or valleys between.
17. In measuring down a slope, draw out the whole tape along the line as if on level ground. Leader raise up the tape and, by direction of the follower lay it as nearly as may be exactly on the line. Hold the 100 ft. mark at the mark where the measurement begins, as before directed. Leader pick up the tape at any convenient place, where it will not be difficult to hold that place up at the same elevation as the 100 ft. mark. This place may not be at a mark on the tape, but it is better to use a regular mark on the tape if practicable.

Leader take his stand beside the tape so the hand and arm used to draw the tape taut will pass across the front of his body, in an easy and comfortable position, steadying himself by pulling the tape taut, and leaving his other hand and arm free to handle the plumb bob and string. The follower can easily hold against the pull of the leader, as he will be holding the 100 ft. mark at, or near, the ground. The leader will be out of line when beside the tape.

Leader hold the bob string at the exact point, or mark, on the tape to be used in this piece measurement. With this place, or mark, held at the proper elevation and on line, let the bob run down nearly to the ground and find where the mark to be made on the ground will come. Clear off the ground. Smooth the surface, if need be. Hold the place on the tape from which the bob string hangs, at different heights, and, by trial, find the height at which the piece of tape being used will mark the longest distance

on the ground. Nip the string tightly to the tape to show how much string to use.

Follower direct the leader to hold the bob exactly on line;—the place where the string is being at the proper height, found as above directed.

When both men are satisfied the conditions are favorable for a trustworthy measurement,—the tape being at a suitable tension and the plumb bob hanging steady and almost to the ground,—the leader lower his hands slightly, without releasing any of the tension, till the point of the bob touches the ground. Leader says "Right," carefully nipping the bob string at the exact place on the tape. Follower let his end of the tape move forward to give the leader some slack. Leader mark the place on the ground where the point of the bob touched.

Verify this mark by further trials, made with care, until both are satisfied the mark on the ground is correct for line and distance.

Follower slip off his handle, pick up the spike, where he is, and advance to the leader.

Leader deliver into the hand of the follower the exact place, or mark, on the tape where the bob string is. This may be done by the follower placing his thumb nail from the 100 ft. side against the thumb nail of the leader from the zero side, and nipping the tape securely, where no regular mark was used.

Follower hold this exact place, or mark, to the mark made beneath it on the ground.

Leader take up any other succeeding convenient part of the tape and measure it off on the ground with the same care, precautions, and tests, as before, for both line and distance.

Follower advance to leader.

Leader deliver his place, or mark, to follower.

Continue these piece measurements on out to the zero of the tape.

Here leave a spike as usual.

Keep the marks on the ground in any convenient way. If spikes must be used, let the leader take one from the follower for every one he puts down between the 100 ft. and zero marks of the tape, at the time he delivers to the follower the intermediate places, or marks, he uses. Another size of nails may be used to mark with between the ends of the tape length.

Both men count the spikes they have at the end of every tape length where the measuring is difficult and see that each has his proper number,—both together having ten.

Continue the measurement at will.

By the method above outlined, a tape length is laid off without any adding of pieces. The tape does the adding and will make no mistakes. It is better to use marks on the tape, if practicable, to designate the piece measurements, as they are less liable to be lost sight of, and can be easily recovered if such is the case.

Be especially particular to keep these short parts of the tape on the line. Slight linear deviations give larger errors on short measures than on the whole tape length. It is much more difficult to keep the line on rough ground.

Ground may be so steep, rough, and covered with obstructions,—rocks, logs, rubbish, hillocks,—that the measurement must be made with a board not over ten feet long, having straight parallel edges and marked with feet and half feet marks. The ground marks must be kept on stakes. The board must be kept level with a carpenter's level, or some similar device,—bubble tubes may be set in the edge of the board itself, and adjusted by reversion on two stakes driven in the ground. The line must be kept by a transit, at, or beyond, the foot of the slope, the measuring proceeding towards the transit. The mark on the lower stake may be made by a heavy, 4 or 5 lbs., plumb bob with a carefully adjusted point,—a millwright's bob might do,—or an accurate plumb rule used. There must be no wind. The piece measurement must be recorded as made, at their actual value, and added. If stakes must be set at equal intervals they must be placed by adding the proper piece measurements at the right places.

18. **Measuring up a slope** is similarly done. On the better class of work, avoid it, as it is especially liable to error. Only men of much experience should attempt it.

## II. MEASURING WITH STEEL TAPES.

### FIELDWORK.

19. **Measuring set.**

One hundred feet steel tape and reel.

Handles for same.

Fifty feet steel tape in its case.

Plumb bobs, with lines,—two.

Six-inch wire spikes,—eleven.

Axe. Stakes,—four.

Line staves may be needed for ranging lines.

Examine the articles as issued, or be liable for defects found upon their return.

20. **Inspection of Plumb Bobs.**

Look for the string,

the point,

the cap,

dents, and

evidences of abuse.

21. **Inspection of Steel Tapes,—50 ft., or short tapes.**

Unwind the tape.

See if the tape is wound wrong side in.

See if the reel works right.

Look for the box,

tape loose from reel,

breaks, splits, cracks, or kinks, in tape,

dirt,

moisture,

rust.



screw holding reel in box,  
 reel handle,  
 knob on reel handle,  
 dents, or bends, in box, and  
 evidences of abuse.

22. **Inspection of Steel Tapes**,—100 ft., or long tapes.

Unwind the tape.

See if the tape is wound wrong side in.

See if the reel works right.

Look for the reel,

breaks, splits, cracks, or kinks, in tape.

dirt,

moisture,

rust,

numbers on tape,

tape handles,

reel handle,

parts of reel,

dents, or bends, in reel, and

evidences of abuse.

23. **Inspection of Line Staves.**

Look for bends,

scratches,

damaged points, and

evidences of abuse.

24. **Reminders.**

If the 100 ft. tape has been mended, test the spaces marked on it.

Keep the tapes wound up,—figures inside.

The zero end of a tape goes ahead.

Count the spikes as directed.

Verify the count between the fifth and sixth spikes.

The spikes the follower has show the distance past the last tally mark.

Verify the count at the last spike set.

Do not pull up the last spike till the record is made.

Record the number of even hundreds of feet.

Record the distance measured with the fifty feet tape.

25. Survey of a triangle, about 450 by 250 feet.

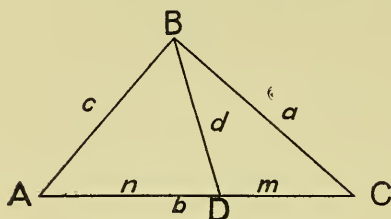

$$d^2 = \frac{(c+n)(c-n)}{b} n$$

$$+ \frac{(a+m)(a-m)}{b} m$$

$$\text{Area} = \sqrt{s(s-a)(s-b)(s-c)}$$

$$s = \frac{1}{2}(a+b+c).$$

26. Instructions.

On rough ground mark a triangle with small stakes, A, B, C, so that A C is, by estimation, about 450 feet, and B is, by estimation, about 250 feet away from A C. Set D anywhere in A C. Be particular to place D exactly on A C. Use a plumb line to range with.

Witness A, B, C, and D, following the form below.

⊙A. A nail in a stake driven flush with the ground, standing on the third prominent ridge N. of the Detroit Observatory, Ann Arbor, Mich., from which a

*Witnesses.* Hickory, 12" in diameter, bears N. about 55° E. 72.'3 to its center, and a

B. Walnut 27" bears S. about 35° E., 261.'4 to cen.

Spike in root of Sycamore 32", S. about 45° W., 47.'13.

Spike, E. face of brick wall near S. E., corner of barn, N.W'ly 34.'27.

Measure A B, B C, C D, D A, and B D. Find the value of  $d$  from the above equation. Subtract it from B D, measured, and show the error + or -. Compute the area in square feet. Reduce this to acres. Make a neat plat of the triangle to scale, on the cross ruled page of the field note book. Record all of these matters in the field note book.

27. Measure the distance, eight times, between two marks about 1000 feet apart. The cement walk on the east side of the campus is about 1000 feet long.
- Drive two stakes, by estimation, about 1000 feet apart, on a smooth piece of ground. Tops of stakes flush with surface of ground. Drive a nail in each stake. Witness each stake. Set up a line staff about two feet beyond each stake, on the line of stakes, and standing plumb.
- Measure the distance carefully between the two nails. Return, measuring the distance carefully, with the same person for leader.
- Change positions, the person acting as follower taking the lead.
- Repeat the measurement, out and back, with the new leader
- Change positions.
- Repeat the measurement out and back.
- Change positions.
- Repeat the measurement out and back.
- Record the measurements as they are made, showing in the book who is leader and who is follower for each one.
- Add the eight measurements. Divide by 8 to find the average measurement.
- Subtract each measurement from the average measurement and write the difference, with its sign, opposite each measurement, forming a column of "Errors."
- Add the errors. See if the sum equals zero. If not, review the calculations and correct the figures.
- Record all these matters in the field note book.

### III. HANDLING INSTRUMENTS.

#### INFORMATION.

#### 28. Transit.

Observe with certainty how it is packed in its box, so it can be properly returned to its place. Do not unpack it and take it from its box until sure it can be put back precisely as found.

Examine the tripod. See that no parts are missing. See that all the shoes on the free end of the legs are tight. See that the wing nuts that clamp the legs to the top casting all have washers, and will clamp the legs firmly to the casting. If a tripod is set up to receive an instrument for use in making observations, the legs will be properly clamped by the wing nuts, in most cases, when they are tight enough so as to just be held in position at the usual slope, without dropping, if the tripod is raised, by its top, off the ground. In a windy time, they may be clamped tighter to steady the instrument. See that the screw on the neck of the top casting is in good order. The tripod being in order set it up on the ground, to receive the transit when unpacked.

Many common transits are screwed on to a board which slides into the transit box with the transit on it. Lift the transit by its base, or its plates, not by its standards, transit axis, or telescope. Set the board in a secure place,—on top of the box will often do, but do not let go of the transit in such a place. Release the spindle clamp. Start the screw that connects the transit to the board. Hold the transit with one hand to keep it from falling, and with the other on the leveling screws, unscrew the transit from the board by turning the base to the left. In this manner separate the transit from the board without danger of it receiving a fall.

In the manner described, or any other method, adapted to the way the transit is packed, take it from the box.

Release the spindle clamp. Release the transit axis clamp.

See that the plumb bob chain hangs central and free from beneath the base plate.

Place the transit on its tripod. With one hand hold of the side of the transit to keep it from falling, and with the other hold of the leveling screws so as to turn the base, screw the base on the tripod. At the last take hold of the base with both hands and make sure the transit is screwed down firmly. If the screw thread in the base plate of the transit does not engage readily with the thread on the tripod, steady the instrument with both hands so the screws bear fair and turn the transit slowly and carefully to the left till the screws drop together. Turn to the right and screw on the instrument.

Take off the cap to the objective of the telescope. Put on the shade. Put the cap in the box where the shade was.

Take the reading glass. Put it in a pocket handy to reach and where it cannot get lost. Some good instrument men tie the reading glass about their necks with a strong string, like a watch.

Take the plumb bob. Tie it on to the chain with a sliding horse knot, tied with a bow, so the bob can easily, and quickly, be set at any required height.

Put the board in the box. Close and fasten it. Set it away in its place.

Turn the telescope straight up and clamp slightly.

Release the spindle clamp if not released.

Put the plumb bob in a pocket.

Take hold of the tripod by two of its legs,—one in each hand,—with the third towards one side of the body. Lift the instrument and draw the legs together with one motion, raising and inclining it to rest, nearly balanced, on the shoulder. Let go of the leg in the hand that is on the same side of the body as the shoulder on which the transit rests, holding the instrument securely with the other. Pass the free hand between the two free legs and grasp the one the other hand holds, releasing that hand. By so doing the instrument always will be held securely.

**29. Setting up Transit. Making a Pointing.**

Take the instrument to the work.

To set the transit down, grasp two tripod legs,—one in each hand,—holding one vertical, and steadying the instrument with the other.

Set the vertical one in its place on the ground, if the transit is to be set up over a mark,—as a nail in a stake.

Grasp the other two legs,—one in each hand,—and spread them out to such a position that the base plate, on which the leveling screws stand, appears to be level when these legs also stand on the ground. The tripod legs should be spread apart far enough so the transit will not only be in no danger of an upset, but so it will stand steady while observing with it.

Take the plumb bob from the pocket and let it hang beneath the transit.

If the transit does not stand over the mark on the ground it is to be set up over, lift it by the tripod, bodily, and move it so it will.

Force the tripod legs into the ground, or spread them apart, or place their feet, so the plumb bob hangs nearly over the mark, and the tripod will stand firm. Instruments are often set up too insecurely to permit of good work being done with them. On a hard surface like rock, or a street pavement, the shoes on the feet of the tripod must be tight or the tripod will wobble on them. Besides they must be set where there is no danger that they will slip.

Release the wing nuts at the tops of the tripod legs. Tighten them again.

Release all the leveling screws, or other device, that permits the use of the shifting center. Shift the transit on its base plate, or shifting center, till the point of the plumb bob hangs exactly to the mark over which the transit is being set up.

Release the clamp to the transit axis.

Release the clamp to the spindle axis, if not already released.

Release all the leveling screws, if not released.

Turn the transit on its spindle, by taking hold of the edge of the plate, or the feet of the standards (not the telescope), so the bubble tubes will stand parallel to opposite leveling screws.

Operate the leveling screws parallel to the transit axis till the bubble tube they control reads level, leaving the screws loose.

Operate the other pair of leveling screws till the bubble tube they control reads level, leaving them a little tight.

Operate the first pair again till the bubble tube they control reads level, leaving them a bit tighter.

Operate the other pair again as before, leaving them tighter.

Operate the first pair again as before, leaving them tighter.

A few touches more and both levels should read level, and the leveling screws be bearing firmly enough so the transit will not turn on the base plate. They must be considerably tighter when there is much wind.

See if the point of the plumb bob hangs exactly to the mark.

If not release the leveling screws, center the transit carefully, and level again. The transit is now "Set up."

Turn the transit on its spindle by taking hold of the edge of the plates or the feet of the standards, not the telescope, or the tops of the standards.

To turn the telescope on the transit axis take hold of the eyepiece end of the body tube, not the eyepiece itself. To reverse the telescope turn the eye end down, take hold of the body tube above the transit axis, not the shade, and complete the reversion.

The leveling screws should always turn with the same resistance, and smoothly, if the instrument is leveled as directed. If this is not the case, clean them, and the hollow screws they work in. When the instrument is leveled the leveling screws should be bearing evenly and firmly,—all alike in every respect.

Place the tripod on the ground, if practicable, so the instrument man will stand between the feet of two of the tripod legs, ordinarily, while at work, and not astride of one of them.



To direct the telescope toward an object, release the spindle clamp and the transit axis clamp, if both are not released. turn the transit on the spindle with one hand to the edge of the plate, and turn the telescope with the other hand to the eyepiece end of the body tube, until when looking over or under, the telescope it appears to be pointed in the right direction.

To find the cross wires, first release the clamps to the transit axis and spindle.

Open the peep hole to the eyepiece.

Direct the telescope to the sky or a light colored object.

Look through the telescope.

Operate the device for moving the eyepiece until the cross wires appear clear, distinct, black lines across the field of view. Make them appear as sharp and well defined as possible.

To focus the objective direct the telescope to look at any object.

Look through the telescope.

Bring the object into the field of view by some slight movements of the transit, if needed.

Move the focussing ratchet to the objective until the object appears as clear, sharp and distinct, as it is possible to make it.

Move the head slightly but still be able to look through the telescope.

See if the cross wires appear to slip about on the object. and it should not be possible to change their relative position by the motion of the head. The view of either the object, or cross wires, or both, may not be quite so perfectly distinct and clear as before these final changes in the setting of the objective, or eyepiece, but should be,

When the objective and eyepiece are both properly focused the cross wires should appear to be painted on the object, and it should not be possible to change their relative position by any motion of the head. The view of either the object, or cross wires, or both, may not be quite so perfectly distinct and clear as before these final changes in the setting of the objective, or eyepiece, but should be.



After the telescope is in proper focus, clamp the spindle and plate.

By means of the slow motion screw to the spindle, make the vertical cross wire cover, or bisect, the object, or mark, sighted to.

This is "Making a pointing."

If the plate must be set at any given reading for a designated pointing, do this by the plate clamp and slow motion screw, before making the pointing.

Make the pointing by means of the spindle clamp and slow motion screw as above.

Read the plate verniers. See if the readings are correct. If so, the pointing is finished. If not, repeat the work till they are.

### 30. Line Staves. Pickets. Sight Marks.

Line staves are used in transit work. A common one is made of  $\frac{1}{2}$ " wrought iron pipe, one end closed, the other steel pointed, about 7 feet long, painted white, with the second, fourth, and sixth foot from the top, or closed end, painted red, or black. A line staff should be straight, true, and the point exactly in the axis of the body of the rod. Set the point of the rod on a board. Twirl it in a vertical position. It should revolve true and not wobble. Watch it at the place where the steel point is welded on. This makes a practical staff for general use. On some city and bridge work a  $\frac{1}{2}$ " solid steel rod, about five feet long, turned true and its point centered in a lathe, painted the same as the pipe, is found to be very satisfactory.

The line staff is held on a point, or mark, from which line is to be taken, or to which an observation is to be made, and used as a mark to sight to. It is also used to find where any line comes by being set in line by the transit.

To hold a line staff, stand squarely behind it as viewed from the instrument; face the instrument; settle the body firmly on the legs with the feet apart, alike on both sides; let the staff pass centrally along the body from the nose down, the person having a sense that the body is plumb; and

hold the staff with both hands brought together at the same place on it, the ends of the fingers and thumbs embracing it, and with the elbows extended alike on both sides. Practice this in calm weather, and there will be less trouble in holding the staff plumb when the wind blows. Sight as near as possible to the point of a line staff. Never trust the line when only two or three feet of the top can be seen.

Many other things are used for marks to sight to in transit work. A plumb bob string, a small nail, or the point of a lead pencil, are suitable marks up to 300 ft. or so; a lead pencil, or one of the 6" spikes from the measuring set, from 100 to 500 or 600 feet. From thence on for a couple of miles the line staff, made of  $\frac{1}{2}$ " pipe is suitable. These distances are subject to modification according to the conditions of seeing. The line staff is used within short distances from the transit. The tendency is to use much too large marks to sight to. Neither is there always sufficient care bestowed in selecting and placing them so the pointing on them will be precise.

One of the more useful marks in transit work is a picket. Where there is timber, cut a stick 1" to 2" thick, about a foot longer than the height of the transit as usually set up. Make a straight blaze along about two feet of its top about  $\frac{3}{4}$ " wide for sights from one to three thousand feet long. Choose the lightest colored wood, as hickory or basswood. Cut the top square across the blaze with a slant back from the blaze. Sharpen the bottom end to go in the ground. Before moving the transit turn its telescope on to the mark where the next set up is to be. Stick up this picket with the straight blaze set to look plumb from the forward set up place, so it will stand firm with the blaze close up to the eyepiece. Range the blaze fairly behind the telescope. If the telescope is inverting, look through it from the objective end. If the picket is not too close the blaze may then be set in the middle of the opening. If the telescope is erecting sight over it, or beneath it and on each side of it. At the new set up set the verti-

cal cross wire to bisect the blaze on the picket at the place that was at the eyepiece. This picket is better than a line staff held up on the mark and dispenses with one man. Any other kind of a stick may be used, as a piece of board.

Short sights should be avoided. Sometimes this cannot be done. Then use a plumb bob string, a fine nail, a pencil point, the back of a pocket knife blade, or some similar small object. In sighting to a plumb bob string, set the cross wire on it as near the place from which it is suspended, as practicable. Often the plumb bob string may be held in the hand grasping a line staff, or long stake, stuck into the ground to one side of the line of vision, and inclined till the point of the bob is exactly to the mark it is desired to sight to. This will steady the hand holding the string.

A picket,—long or short,—of suitable thickness may be stuck in the ground back of a mark and inclined over the mark till a plumb bob string held to the center of its top brings the point of the bob to the mark. Sight to the top of a picket set in this way, where the plumb bob string was.

A very useful mark to sight to, both for short sights and those up to a thousand feet, or more, is made by sticking a nail, fine, or thicker, as may be needed, twice through a piece of white paper so that the paper will form a background for the nail when set in line. Fold the paper, or cut it, into a rectangle. Stick the nail exactly central in the paper and parallel to the sides of the rectangle. This mark is often used by first setting the cross wire on the line where it is to be set by reference to a mark on that line by some other means, as a line staff, or a plumb line, and then setting the nail on line with the transit. Drive the nail plumb. After the nail has been set test the steadiness of the transit by again sighting to the reference mark. The person with the line staff or plumb line can then be released for other duty, the nail being used for reference. If prepared and set as directed, this mark can be referred to for line, from any place where the paper can be distinctly seen.

In sighting to a stick or mark of any kind, set to show a line, use the very spot that was set on the line, not the other part.

### 31. Locating a Mark.

To locate a mark on a designated line, set up the transit at a mark on that line, and set the line of sight (vertical cross wire), on another mark on that line, as above directed.

Turn the telescope on the transit axis to look to the place where the new mark is required. Set a line staff in line at this place. Drive a stout stake, or plug, where the staff stood till flush with the ground. While the stake, or plug, is being driven, see that the point of the plumb bob is to the mark, that the plate levels read level, and that the vertical cross wires strike the other mark on the reference line. When the plug is down, and the transit exactly set, and standing so, set the staff precisely in line on top of the plug,—the staff being plumb. Look again to the stability of the transit, and, finding it secure, signal "All right." Drive a small wire nail at the mark in the plug made by the point of the staff, leaving the head up a little. There are many other ways of marking points.

Measure and record, distances from the nail in the plug to three, or more, of the nearest and most permanent objects, such as trees, foundations, hydrants, lamp posts, or pumps, with their directions from the plug and plain descriptions of them. Also measure and record the distance from the nail in the plug to some other mark on the same line.

### 32. Signals.

Stand squarely behind the transit when giving signals. Make the motions slowly, especially if they are to be read at some distance. It is usual to move too quickly in giving signals. To say "Move the line staff to the right," stretch out the right hand and arm level.

To say "Move the line staff to the left," stretch out the left hand and arm level.

Let one down by the side before raising the other.

To say "All right," raise both hands above the head and with the arms fully extended, bring them slowly down to the sides.

To say "Hold up the line staff," throw the weight onto one foot and extend the opposite hand and arm as high as they will reach.

To say "Plumb the line staff," incline the head in the direction the top of the staff should go.

To say "Come here," beckon with the hat, or head covering. The transit man should not "move up" until called in this way.

Many additional special signals will grow up in any party working for some time on the same work.

The signals with a handkerchief, a flag, or the like, are based on those given.

To the right,—show the flag to the right.

To the left,—show the flag to the left.

All right,—wave the flag slowly back and forth, aloft.

Hold up staff,—stretch up the hand with the flag in it.

Plumb the staff,—stretch up the hand with the flag in it and incline the flag in the direction of the top of the staff should go.

Come here,—raise the flag staff with the head cover on its top.

A whistle is very useful for signalling. It is made of tin, with a "barrel" about one inch in diameter. Most tanners know how to make one.

To the right,—one blast.

To the left,—two blasts.

All right,—three blasts.

Hold up the staff,—one long blast.

Plumb the staff,—one rather long blast followed by one toot for top to the right, or two toots for top to the left.

Come here,—two long blasts.

Something in the way,—repeated short toots.

Come back and clear out the line,—short toot, then a blast, repeated as the axeman comes back till he is brought to the spot. He may get too far back.

Go ahead,—a blast, then a short toot. So bring him to the spot. Then signal him right, or left, as above, and also Up,—two toots and a blast.

Down,—a blast and two toots.

So it is possible to bring his hand to the thing that makes the trouble. When he has the line clear, give him,—All right,—Go ahead.

All hands this way,—four blasts.

The above are illustrations which may be greatly extended if occasion requires.

Right and left must always mean with respect to the direction in which the line is going and not the direction in which the telescope on the transit may chance to be looking.

### 33. Putting away Transit.

Bring in the transit when through work.

See that it is in good order for immediate use. If not, make it so.

Put it in its box at once. Do not leave it standing around on its tripod.

The place for an instrument is in its box, when not in use.

The place for the box, with the instrument in it, is where the temperature is steady and where it will be let alone.

Keep in the box with the instrument a fine camel's hair brush and a piece of the softest chamois skin for the lenses.

keep there another camel's hair brush, such as painters use, about an inch wide, for dusting off the instrument; also soft cloths for wiping it.

Take off the plumb bob, wind up its string neatly, and put it in its place in the transit box.

Put the reading glass in its place in the box.

Release the spindle and transit axis clamps, if not released.

Take off the shade and put it in its place in the box.

See if the objective and outside eyepiece lens need dusting off. If they do, dust them off with the lens brush. They may need slight wiping with the chamois. Beware of scratching them.

Close the cap to the eyepiece.



Cover the objective with its cap after seeing that the cap is clean.

Dust off all parts of the instrument with its brush, if it needs dusting. Wipe it with cloths if required.

Release the leveling screws.

Place the transit central on its base plate.

Tighten the leveling screws rather firmly, making them all even so the plates between which they work will be parallel.

Unscrew the instrument from its tripod.

Screw it on to its sliding board, if there is one.

Clamp the spindle and release the plate clamp.

Slide the board into the box carefully with the instrument on it and in its proper position.

By trial and examination set the telescope and other parts so as to be as clear of the box as possible.

Clamp the plate and transit axis but not very hard.

See that the door of the box shuts freely,—no crowding.

Close the box. Fasten it. Lock it. Put the key away. Set the box in its place. Close and strap the tripod. Put it away in a safe place.

If there is no sliding board, place the transit in its box in its proper position, so the spindle clamp and transit axis clamp are accessible. When the instrument is securely placed clamp those clamps slightly, also the transit axis clamp. See that the box closes freely. Close and lock it, and set in its place.

If an instrument comes in wet wipe it off with soft cloths and brush the moisture off the outside of the objective and eye lens with the lens brush, or wipe them with the chamois, or both.

Unscrew the instrument from its tripod, and set it in a warm (not hot) place to dry, where it will not be touched.

If there is water between the glasses of the objective, or within the eyepiece, or inside of the tubes, or between the plates, let the instrument stand in a warm place for some time (say over night) and it may come out. Do not make haste to be taking things apart to get it out. While waiting for the transit to dry, put the reading glass, plumb

bob, and shade in their places in the box. Leave the cap off of the objective and the eyepiece cap open till the instrument is dry. When it is dry, dust and clean it, if it needs it. See that the parts are working freely. Put it away in its box.

If an instrument has to be transported, have a packing case well upholstered within on all six sides to set the instrument box in. It should fit snug.

For the reading of an angle see 50.

### 34. Level.

For information relating to the following subjects read what is said regarding them under Transit. There should be no difficulty in applying the statements to the handling of a level.

Packing in its box.

Tripod.

Screwing to tripod.

Cap over objective, and shade.

Setting box away.

Carrying on shoulder.

Setting down. Does not have to be set up over a mark.

Finding crosswires.

Focussing objective.

Lift the level by its base or by the bar upon which the telescope is mounted,—not by the telescope.

In leveling this instrument, turn the bar to stand over a pair of leveling screws.

Operate this pair till the bubble tube reads nearly level, leaving the screws loose.

Turn the bar over the other pair of leveling screws.

Operate this pair till the bubble tube reads level, leaving them a little tight.

Turn the bar back over the first pair,—do not reverse it.

Operate this pair again till the bubble reads level, leaving them a bit tighter than the other pair.

Turn the bar back over the other pair,—do not reverse it at any time while leveling this instrument.



Operate this pair till the bubble reads level and they are as tight as will be needed.

Turn the bar back over the first pair.

Operate them till the bubble reads level, and they are tight enough.

A few touches more and the bubble should read level in both positions. The bubble tube is much more sensitive than those in the plate levels of a transit and correspondingly more difficult to set to read level.

The leveling screws should bear evenly, not too tight, and turn by the application of the same force to each. They need be only tight enough to hold the bubble level. When there is no wind at all they may be entirely loose, the level standing upon their bottom ends, with no pressure on the ball and socket joint in the base plate.

The level is then ready for observing, although may be the bubble will not read level if the bar should be reversed.

It is now said to be set up.

### 35. Leveling Rod.

There is used with a level, a leveling rod.

This is an accurately divided wooden rod. The unit of division may be anything, but the foot and the meter are probably the most used.

There are target rods and speaking rods,—so-called.

On the target rod is a target, or two in some cases, to which the pointing of the level is made. After the target has been set by direction of the leveler, the rodman reads the distance of the sight line on it from the zero of the divisions, or graduations, usually with the aid of a vernier.

The speaking rod has no target. The leveler reads the rod without assistance from the rodman, by noticing where the horizontal cross wire appears to lie on the graduations.

The target rods in most common use in the United States are the Boston Rod, the New York Rod, the Philadelphia Rod, and the Troy Rod. There is some choice in the kind and plan of a rod for different kinds of work.

The targets in common use are of a pattern which introduces a considerable uncertainty into the rod readings, especially when at some distance from the level. These patterns can be easily improved by using central white spaces on the target, of increasing width towards the sides of the target, these spaces to be bisected by the horizontal cross wire, using the wider ones on distant sights. These spaces should be rectangular in form.

Speaking rod patterns are of a very great variety of forms. avoid those containing oblique lines, points and sharp angles. The pattern should be made up of rectangles, painted alternately white and black. The pattern should be so arranged that the horizontal cross wire will always lie on a white surface, except at the edges of the black rectangles. The rectangles may be one-tenth of a foot high, or a half a tenth of a foot, the hundredth of a foot, where needed, being estimated by the leveler.

Do not infer because a target rod is read to thousandths of a foot by a vernier, while the hundredths of a foot on a speaking rod are "Guessed at," and the thousandths "Thrown away," that the target rod is either more precise or more trustworthy.

Target rods are made in more than two pieces, for obtaining a longer extension, or a shorter length when closed.

Speaking rods are hinged, or jointed, for compactness. They are also made in the form of a broad tape, to be fastened to a board for use, and rolled up when not in use,—the "Flexible" rod. For many uses, take a strip of wood of any suitable length,  $\frac{7}{8}$ " x 2", and tack on to it a piece of a metallic tape measure. Mark off, on the stick, the even feet from the steel tape, and tack on the tape so its foot marks fit these. This rod may be of any length, up to fifteen feet. It is very useful on rough work.

The leveling rod is used for measuring the vertical distance between the line of sight of the level and any object. The object may be below the line of sight of the level, as is commonly the case in surveys upon the surface of the ground, or above it, as in overhead work, which may be

met with in tunnels, mines, setting of steel beams, or in leveling shafting.

The rod is used by holding it vertical, or waving it slightly, so as to measure the shortest distance from the line of sight of the level to the object upon which the foot of the rod is held. In leveling shafting, a large hook is sometimes screwed into the foot of the rod and the rod hung from the shafting by this hook. A hook with a square turn is used, also one with a circular curve of a larger radius than the shafting. The latter can be used on shafting of any size smaller than the curve of the hook, while the hook with the square turn sets lower on the smaller shafting and requires a correction to the rod reading in addition to that for the size of the shafting when the axis of the whole line, it may be containing different sizes, must be placed at the same height.

When using a target rod, the rodman should move the target as directed by the leveler, with an uniform, steady, even, motion, not by jerks, and spurts.

When using a speaking rod the rodman should be very particular to hold it plumb. Read the suggestions for holding a line staff plumb.

When using any rod the rodman should stand squarely back of the rod and face the level.

### 36. Signals.

Target to be moved down, leveler lowers his hand and shows the back of it to the rodman, who keeps the target going down with an even motion until stopped by a signal from the leveler.

Target to be moved up, leveler raises his hand and shows the inside of it to the rodman, who keeps the target going up with an even motion until stopped by a signal from the leveler.

As the sight line on the target approaches the horizontal cross wire the leveler quickly throws his hand and arm out to a horizontal position in time to catch the target with its sight line on the cross wire. This he will soon learn

to come very near doing. The rodman seeing this signal, as quickly stops the target and holds it from slipping. A slight adjustment of the target will bring it exactly to place.

The leveler extends both arms to say "All right."

To say "Plumb the rod," the leveler inclines his head the way the top of the rod should go.

To say "Wave the rod," the leveler raises his hand above his head and waves it back and forth towards and away from the rod.

To say "Hold up the rod," the leveler throws his weight on to one foot and raises his opposite hand as high as he can reach.

To say "Clamp the target" or "Clamp the rod," the leveler whirls his hand around as if turning a crank.

In a wind the rodman may not be able to make the leveler hear distinctly his call of the figures in the reading of a target rod. It is quite easy to mistake "five" for "nine." The rodman lays his rod on the ground and stands facing across the levelers line of vision. He extends his arms wide apart vertically and brings the palms of hands together, not too quickly, as many times as there are units in the figure he wishes to communicate,—as seven times for figure seven. He makes a short pause. He makes the next figure in the same way, and so on till the leveler signals "All right," that he understands them all.

To say "Repeat the rod reading," the leveler waves his hand with jerks and mixed movements, signifying confusion.

A rod is "Read" by repeating the figures of the entire reading, speaking the feet (or other units) first,—as "Eleven,"—pausing slightly, and following with the figures in their order in the decimal part of the reading.

Shouting, noise, and racket, are no part of surveying. Keep as quiet as possible, and give undivided attention to the work. It takes this to avoid errors, mistakes, and blunders.

"Short rod" means a movement of the target within the length of the foot piece, or bottom piece, of the rod.

"Long rod" means a movement of the target beyond the length of the foot piece of the rod.

For long rod with the "New York" or "Philadelphia," rod set the target exactly to the short rod reading at which the long rod reading begins,—as at 6,500, on some New York rods. Be particular about this, or the long rod readings will be wrong.

For long rod with the "Boston" simply invert the rod and take the reading from the other vernier.

For long rod with the "Troy" rod, the leveler sights to the upper target and adds the distance,—as 6 ft.,—between the sight lines of the targets, to the reading from the vernier.

### 37. Taking a Rod Reading.

Hold the rod vertically with its foot on the object upon which a rod reading is to be taken.

Direct the telescope to look at the rod.

Focus the objective sharply on the rod.

See if the bubble reads level. If not, start the leveling screws that are nearest parallel to the level tube slightly and set them so the bubble will read level and stand at that reading.

By directions from the leveler, the rodman sets the target so its sight line precisely matches the horizontal cross wire.

Clamp the target.

See if the bubble still reads level. If not, repeat the work, till it does.

Wave the rod slowly back and forth, towards and away from the level, past the vertical both ways, if the rod reading is over six feet. If there is much wind wave the rod for a reading of over four and a half feet.

See if the target is set to match its sight line precisely to the cross wire once in its path, as it is waved, and passes below the wire each way from that one place.

See if the bubble reads level.

When satisfied read the rod.

Do not wave the rod for a short reading,—say up to two or three feet,—or the reading will be wrong.

Always be sure the bubble reads level for every rod reading whether the level is in adjustment, or not.

The above directions provide for a rod reading having all the precision possible, with the instruments used. Such rod readings should be taken on all Bench Marks, Turning Points, or other objects, upon which the transfer, continuation, or preservation, of the levels depend.

In placing pegs, or other marks, for construction it is customary to read the rod to hundredths of a foot, and not to use quite the extreme care above outlined.

In taking rod readings on the surface of the ground merely to get its elevation, it is customary to seek to obtain their correct value to the nearest tenth, or half tenth, of a foot, and much less care is needed.

The above directions for the target rod may be adapted to the use of the speaking rod.

### 38. Putting away Level.

Bring in the level and rod when through work.

See that the level is in good order for immediate use. If not, make it so.

Put it in its box at once. Do not leave it standing around on its tripod.

The place for an instrument is in its box, when not in use.

The place for the box, with the instrument in it, is where the temperature is steady and where it will be let alone.

Keep in the box with the instrument a fine camel's hair brush and a piece of the softest chamois skin for the lenses.

Keep there another camel's hair brush, such as painters use, about an inch wide, for dusting off the instrument; also soft cloths for wiping it.

Take off the shade and put it in its place in the box.

See if the objective and outside eyepiece lens need dusting off.

If they do, dust them off with the lens brush. They may need slight wiping with the chamois. Beware of scratching them.

Close the cap to the eyepiece.



Cover the objective with its cap after seeing that the cap is clean.

Dust off all parts of the level with its brush if it needs dusting. Wipe it with cloths if required.

Release the leveling screws.

Tighten them rather firmly, making them all even so the plates between which they work will be parallel.

Unscrew the level from its tripod.

Put the level in its box.

See that the box closes freely,—no crowding.

Close the box. Fasten it. Lock it. Put the key away. Set the box in its place.

Close and strap the tripod. Put it away in a secure place.

In case a level comes in wet follow the instruction given for the transit when wet.

If a level has to be transported, have a packing case well upholstered within on all six sides to set the instrument box in. It should fit snug.

### 39. Putting away Leveling Rod.

See that the leveling rod is in good order for immediate use.

If not, make it so.

Put it away in its place at once. Do not leave it standing around.

Dirt and damage from use, or abuse, make a rod worthless.

Clamp screws can be cleaned. Leave no oil when done.

Clamps can be refitted.

Metal parts can be fastened better.

Fixed targets, as on the Boston Rod, can be fastened on more securely.

Common hard soap will lubricate clean wooden parts.

If the rod is dim to read from dirt, wash it with soap and water.

## III. HANDLING INSTRUMENTS.

## PRACTICE.

Setting up, and putting away instruments.

## 40. Transit.

Outfit.

Transit.

Axe, stakes, and nails.

Line staff.

Examine the articles as issued or be liable for the defects found upon their return.

## 41. Inspection of Transits.

Try all clamps and slow motion screws.

Try all rotary motions.

Spindle axis.

Plate.

Verniers.

Transit, or telescope axis.

Try focussing motions.

Objective slide.

Eye piece.

Try leveling screws.

If not on center of base plate with leveling screws even and firm, return to user.

Look for cross wires,  
plumb bob chain,  
reading glass,  
plumb bob,  
shade,  
cap over objective,  
screw driver,  
adjusting pins,



camel's hair brushes,  
damage to box,  
broken, or cracked, bubble tubes,  
scratches on the objective,  
cap on eyepiece, and  
evidences of blows, upsets, or abuse.

Examine all circles and their verniers for scratches,  
dents, and injuries of any kind.

#### 42. Inspection of Tripods.

Look for shoes,  
loose shoes,  
wing nuts,  
bolts,  
breaks, or splits, in legs,  
damage to top screw,  
cover cap,  
dents, or bends, in top casting, and  
evidences of misuse or abuse.

#### 43. Reminders.

Observe narrowly how the transit is packed in its box.  
See that the shoes on the tripod are tight, and the screw on  
it in good order.  
Lift the transit by its plates, or base,—not by the transit axis  
or standards.  
Put the cap in the box.  
Put on the shade.  
Take the plumb bob and reading glass.  
Put the box away.  
Release all the leveling screws before beginning to level the  
transit.  
Focus the telescope carefully.  
Make pointings with precision. Bisect the mark accurately.  
Sight to the bottom of the line staff, if practicable.  
Use good stakes,—no splinters.  
Use good plugs,—4" or more, across the top,—driven flush  
with the ground,—not stakes. These for instrument points.

Make good notes. They cannot be too good.

Watch all the stuff all the time, or some of it will get lost.

Each person be responsible for certain articles.

Before moving away from a work place, find all of the outfit and account for every article.

When through work, put everything away, in order for immediate use, and in its place.

44. **Take a transit out of doors.** Set it up properly over a nail in a stake, or plug. Learn and operate the different motions and parts. Find the cross wires. Set the line of sight on a mark. Locate a new mark, as a nail in a plug, on the line to the mark sighted to. Take down the transit, repack it in its box properly, and put it away.

45. **Level.**

Outfit.

Level.

Leveling Rod.

Axe, and stakes.

Examine the articles as issued or be liable for the defects found upon their return.

46. **Inspection of Levels.**

Try clamp and slow motion screw.

Try rotary motions.

Spindle axis.

Telescope in wyes.

Try focussing motions.

Objective slide.

Eyepiece.

Try leveling screws.

If not even and firm, return to user.

Look for cross wires,

shade,

cap over objective,

screw driver,

adjusting pins,

camel's hair brushes,  
damage to box,  
broken, or cracked, bubble tubes,  
scratches on objective,  
cap on eyepiece, and  
evidences of blows, upsets, or abuse.

#### 47. Inspection of Leveling Rods.

Try the clamps.

Try the slide.

Look for clamp screws,—bent, broken, or lost,—  
loose target, on Boston, or Troy, Rods,  
scratched, or bent, target, dirt,  
scratches on scales, or face of rod, dirt,  
damaged, or lost, verniers,  
splits, or breaks, in tongue and groove, and  
evidences of blows, falls, or abuse.

#### 48. Reminders.

See how the level is packed in its box.

Examine the tripod.

Lift the level by its base or bar.

Put the cap in the box:

Put on the shade.

Put the box away.

Release all the leveling screws before beginning to level the instrument.

Focus the telescope carefully.

Set the target accurately.

See that the bubble reads level for every rod reading.

Hold the rod plumb.

Watch all the stuff all the time, or some of it will get lost.

Each person be responsible for certain articles.

Do not set a leveling rod where it is liable to fall down and be broken. This is too common. Lay it on the ground.

When through work, put everything away, in order for immediate use, and in its place.

49. Take out of doors, a level and rod. Set up the level. Learn and operate the different motions and parts. Having set it up firmly and leveled it carefully, take a rod reading on a B. M. Find H. I. Take other rod readings on various places and find their elevations. Take down the level, repack it properly in its box, and put it away. Put the rod away.
- Learn to use both the target rod and the speaking rod.

## IV. SURVEY OF A TRIANGLE.

### INFORMATION.

#### 50. Reading an Angle.

Set up the transit over the mark at the vertex of the angle.

Clamp the plate. Set the line of sight on the object which marks the left hand side of the angle, using the spindle clamp and slow motion screw. See that the plate levels read level.

Read the plate. Record the readings.

See that the line of sight still strikes the object on which it was set.

By repeated examinations make sure the transit is stable, level, the line of sight on the object, and the plate readings recorded correctly.

Release the plate clamp.

Set the line of sight on the object which marks the right hand side of the angle, using the plate clamp and slow motion screw.

See if the plate levels read level. If much out repeat all the previous work and adjust these levels if necessary. So make sure of the setting of the transit for the second object.

Read the plate. Record the readings.

See that the line of sight still strikes the object upon which it was last set.

Release the plate clamp.

Set the line of sight again on the left hand object, using the plate clamp and slow motion screw.

See that the plate levels read level.

Read the plate. Record the readings.

See that the line of sight still strikes the left hand object.

See if the first and last readings are alike, or nearly so. If not, repeat the work till they are

Follow the form herewith.

Reduce the value of the angle by one of the methods shown.







1897-10-26

Reading the Angles of a Triangle.

Temperature unseasonably high.  
Sun shining with a burning heat.  
Moisture in air bad. Seeing poor.  
Instrument affected by the heat.

A. B. C. Designate the vertices of this tri

o A Is a nail in a stake driven flush  
ridge S. of Detroit Observatory, Ann  
Hichory 12" in diameter bears N. about  
B. Walnut 27" in " " S. "

o B Is a nail in a stake driven flush  
Spring St. & Chubb Road, Ann A  
corner fence post. Other witnesses

o C Is an iron pipe 3/4" x 36" driven  
in S. W. corner of the field next S. E.  
about 20' from fences.

Witnesses. Cen. B. O. 18" N. 30°?  
Cen. Hich. 13" S. 65°?

To see how near to 180° 00' 00" their sum  
would come.

Transit 1641.

Party. Alcibiades Drynoodle.

Antiochus P latitude.

Both read the angles independently.  
Each recorded for the other.

angle.

with the ground on the first prominent  
n Arbor, Mich., from which a  
55° E. 73.3 to its center, and a  
35° E. 261.4 " " "

with the ground in the S. E. angle of  
Arbor, Mich. about 4:0 N. W'ly from the  
should be taken.

flush with the ground, on the high ground  
of Freeman's Park, Ann Arbor, Mich.

W. 113.6

W. 217.9

A. Platitude.

To p. 30.





From p. 29  
1897-10-26

# University of Michigan.

## Angles of Triangle A. B. C.

At  $\odot A$ .

Ver. A.	Ver. B.		
16° 20' 30"	196° 21' 00"	20' 45"	
77° 13' 00"	257° 12' 45"	12' 52".5	12' 52".5
16° 20' 00"	196° 20' 00"	20' 00"	20' 22".5 60° 52' 30"

At  $\odot C$ .

221° 16' 30"	41° 16' 15"	
256° 23' 00"	76° 24' 00"	
221° 17' 00"	41° 16' 30"	
16' 45"	16' 22".5	
35° 06' 15"	35° 07' 37".5	35° 06' 56".25

At  $\odot B$

347° 22' 15"	167° 21' 45"	
71° 22' 00"	251° 22' 30"	
347° 22' 15"	167° 22' 30"	
83° 59' 45"	84° 00' 45"	
83° 59' 45"	84° 00' 00"	
59' 45"	00' 22".5	
		84° 00' 03".75
		179° 59' 30"
		180° 00' 00"
		+ 0° 00' 30" Error

# Department of Engineering.

Ann Arbor, Mich.

A. Dymnoodle Inst.  
A. P. Platitude Rec.

S. W'ly to  $\odot C$ .  
 N. W'ly to  $\odot B$ .  
 S. W'ly to  $\odot C$ .  
 W'ly Angle.

N'ly to  $\odot B$ .  
 N. E'ly to  $\odot A$ .  
 N'ly to  $\odot B$ .  
 N. E'ly Angle.

S. E'ly to  $\odot A$ .  
 S'ly to  $\odot C$ .  
 S. E'ly to  $\odot A$ .

S. E'ly Angle.

A. Platitude.



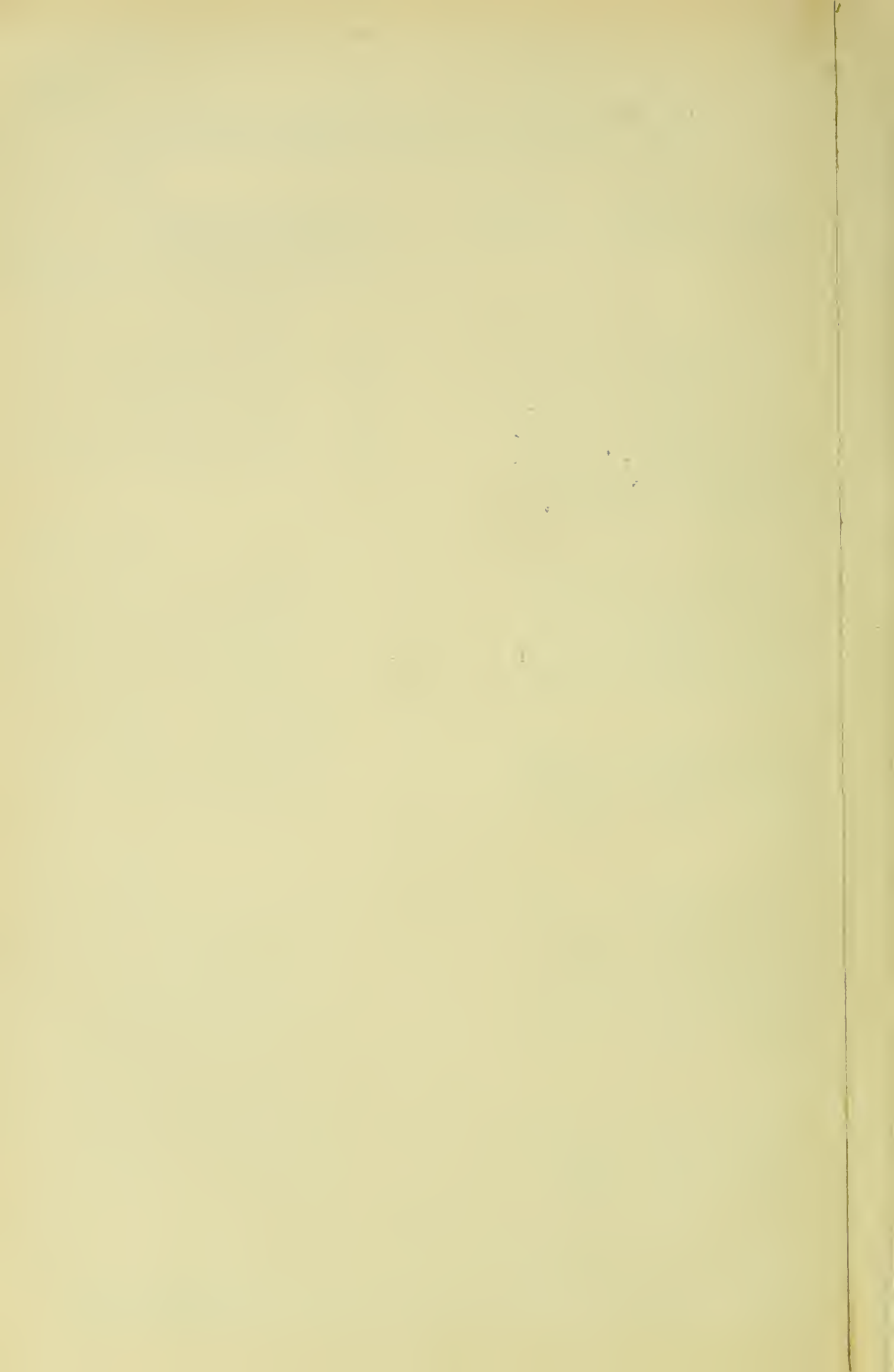

## IV. SURVEY OF A TRIANGLE.

### FIELDWORK.

#### 51. Outfit.

Transit.

Measuring set.

Axe, stakes, and nails.

Examine the articles as issued, or be liable for defects found upon their return.

#### 52. Stake out a triangle with sides about 500 ft. long. Estimate their length.

Designate the stakes by A, B, C.

Record a description of each stake, and its general location, under its letter, in the note book. Take four, or more, witnesses to each stake. Record these witnesses with the description of the stake.

⊙A. Is a nail in a stake 1" x 2" driven flush with the ground in the S.W. corner of the second field N.W. of John Smith's house on the N.E. side of the South Ypsilanti Road about  $1\frac{3}{4}$  miles S.E.'ly from State St. in Ann Arbor, Mich., from which a  
*Witnesses.* Swamp Oak 14" in diameter, bears N. about  $50^\circ$  W. 8'.45 to its center, and a  
Pear tree 6" bears N. about  $25^\circ$  E. 184'.7 to cen.  
Spike in root of Soft Maple 20" S.  $86^\circ$  ? E. 42'.19.  
4'.3 W'ly to range of E'ly corner of barn about 10 rods S'ly, and the peak of the N.E'ly gable of the next dwelling S.E'ly from said barn on S.W'ly side of highway, above named.

Similarly for ⊙B and ⊙C.

Read, record, and reduce, the angles of this triangle, following the instructions and form, given above.

Use small marks to sight to,—a nail, a spike, or a pencil.

Measure the sides of this triangle, with the steel tapes.

Record these measurements.

Verify the work by adding the angles, and by the sine equation,  $b \sin A = a \sin B$ , &c. Record the discrepancies.



## IV. TWENTY ROD READINGS

On the Same B. M.

## . FIELDWORK.

53. **Outfit.**

Level.

Leveling Rod,—target rod.

Axe, and a stake.

Examine the articles as issued, or be liable for defects found  
Upon their return.

54. **Directions.**

Set up the level firmly and level it carefully.

Drive the stake 350 or 400 ft., estimated, away from the  
level, about flush with the ground.

Rodman take leveler's notebook.

Rodman hold up the rod on top of the stake.

Set the target as precisely as possible. Be sure the bubble  
reads level.

Rodman record the reading of the rod in the leveler's book  
according to the form below, without calling off the same.

Leveler start the leveling screws sufficiently to throw the  
bubble away from its level reading. Do not disturb the  
level otherwise.

Level the instrument again carefully.

Take a second rod reading as precisely as possible.

Rodman record the reading as before.

Start the leveling screws again.

Repeat these operations, using the utmost care, until there  
are twenty rod readings recorded in the leveler's book.

Change places, and do the same work again.

Add the twenty rod readings.

Divide the sum by 20.

Subtract each rod reading from the quotient, or average  
reading.

Record the discrepancies, each with its proper sign.

Add them. See if their total sum is zero.

This is a device sometimes used to check the average result.

It is not a very safe check, as it does not verify the various  
steps in the process.



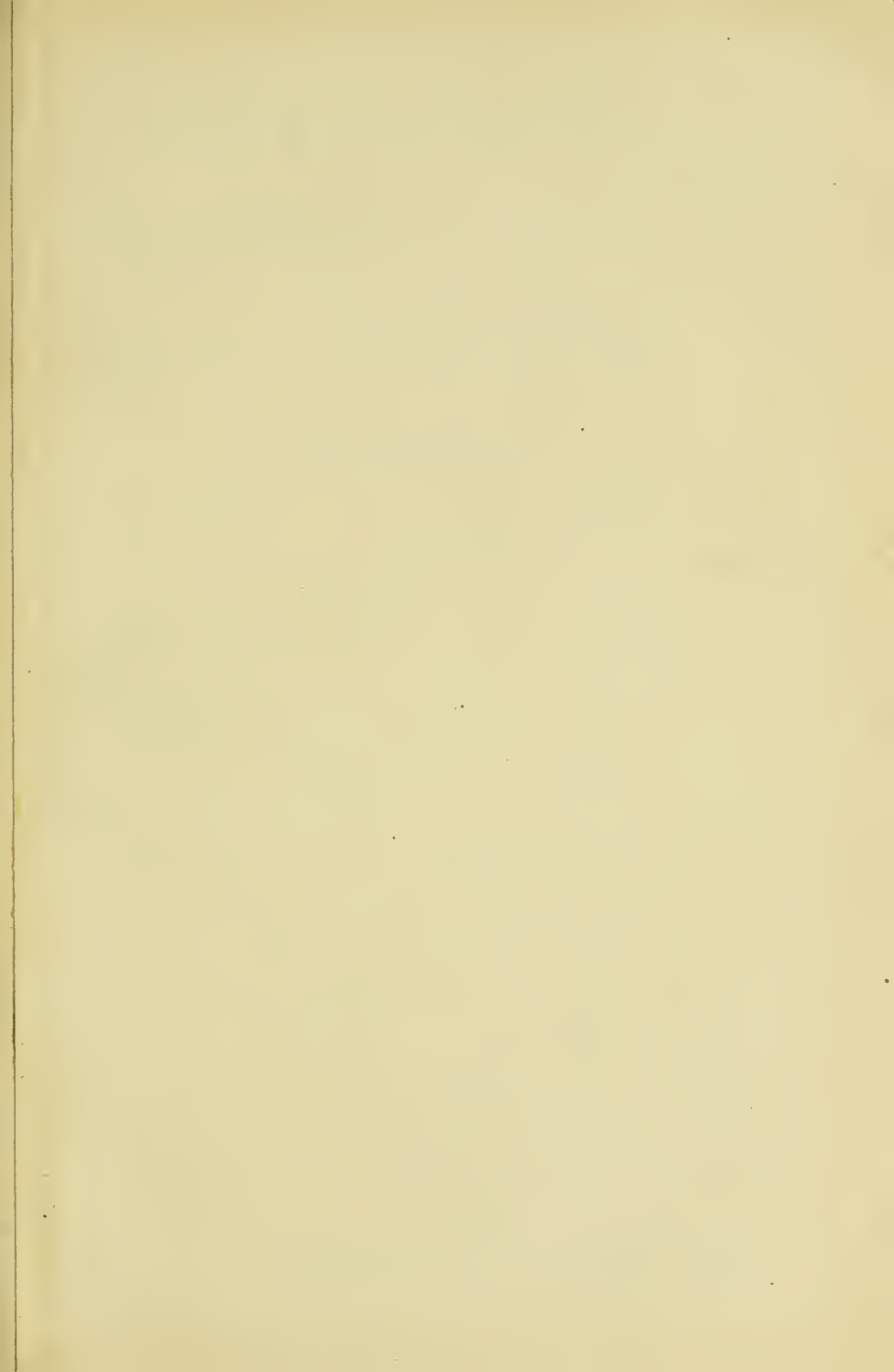



1909-9-8

University of Michigan.

I wenty rod readings on the

Both took twenty rod readings.

Rod.	Discrepancies.	
	+	-
1. 6.398	.00165	
2. 6.407		.00735
3. 6.405		.00535
4. 6.397	.00265	
5. 6.395	.00465	
6. 6.400		.00035
7. 6.402		.00235
8. 6.396	.00365	
9. 6.398	.00165	
10. 6.399	.00065	
11. 6.401		.00135
12. 6.400		.00035
13. 6.398	.00165	
14. 6.396	.00365	
15. 6.395	.00465	
16. 6.399	.00065	
17. 6.404		.00435

Department of Engineering.

same B.M.

Level 413.

Party. Bascule Bumpus

Makepeace Warworm.

Each recorded the other's readings.

Rod	Discrepancies.	
	+	-
18. 6.401		.00135
19. 6.402		.00235
20. 6.400		.00035
20) 127.993		
6.39965		
	.02550	.02550

Makepeace Warworm. Rec.

10 11

## V. READING ANGLES. CLOSING THE HORIZON.

### FIELDWORK.

#### 55. Cut 7<sup>+</sup>.

Transit.

Axe, and a stake and nail.

Examine the articles as issued, or be liable for defects found upon their return.

#### 56. Directions.

Take the transit to a place commanding a view around the horizon.

Drive the stake flush with the ground and drive the nail in its top.

Set up the transit firmly. Level it carefully.

Select five, or more, objects at distances away of from half a mile to two miles, so as to divide the space around the horizon into five, or more, angles.

Read, and record, each of these angles separately.

Each person read each angle independently.

Do not set the plates to read zero.

For the nearer objects use a joint in the brick work of a chimney, a sash bar in a window, or some similar small object to sight to. At a greater distance the corner board on a house, the post on a porch, the finial on a cupola, or some similar somewhat larger object that can be bisected precisely, make suitable marks to sight to.

Reduce the angles.

Add them. See if the sum equals  $360^\circ$ .

Record the discrepancy.

## V. PEG LEVELS. SHORT CIRCUIT.

## FIELDWORK.

## 57. Outfit.

Level.

Leveling Rod.

Axe. Pegs. Piece of chalk.

Examine the articles as issued, or be liable for defects found upon their return.

## 58. Directions.

To find the difference in elevation between two objects not far apart. Involves three or four settings of the level. Done to learn the process. Follow the form, given below, for the record.

Set up the level firmly, not over 350 ft. away from the place from which the leveling is to proceed, and where it will be convenient to continue towards the place the levels are to run to. Level the instrument carefully.

Take a rod reading with precision on B. M.

Record it in the + S column.

Rodman find a suitable place for a turning point not over 350 ft. from the level and where it will be convenient for continuing the leveling. Such places are tops of stones fast in the ground, tops of curbs, cement, or stone, walks, cross walks, or tops of hydrants. On a large surface like a curb or cross walk mark the place the rod is held up on with chalk, or otherwise, so it cannot be mistaken, and can be found again. If no such place is found, drive a peg in the ground till it stands firm and is nearly flush with the surface. Use the top of this peg for a turning point.

Take a rod reading with precision on T. P. (turning point).

Record it in the — S column on the next line below the last rod reading in the + S column.

Take up the level,—after the record is made, not too quickly. Set it up not over 350 ft. beyond the T. P. on the way the levels are to go.

- Take a rod reading with precision on the T. P.  
Record it in the + S column on the same line as the last rod reading in the - S column.  
Rodman, find, or make, the next T. P.  
Take a rod reading on it, as before.  
Record this in the - S column on the next line below the last rod reading in the + S column.  
Move the level, as before.  
Continue the work in this manner until a rod reading is taken on the place to which the levels run and is recorded in the - S column.  
Let the level stand.  
Continue the record as above outlined, and as per form.  
Leveler take the rod. Rodman take the level.  
Repeat the rod reading on the place the levels were run to, preparatory to returning on the same pegs.  
Record this in the second + S column on the same line as the previous rod reading on the same place in the first - S column.  
Repeat the rod reading on the last T. P.  
Record this in the second - S column on the next line above the last rod reading in the second + S column.  
Move the level.  
Continue the work back to the starting place, until a rod reading is taken on the B. M. where the levels began.  
Record the successive rod readings in the second + S and - S columns, proceeding up the page as in the form.  
Add the rod readings in each + S column.  
Add the rod readings in each - S column.  
Add, with their signs, each pair of these sums, that is, find the algebraic sum of the rod readings taken on the way out, and of those taken on the way back.  
See if these results have opposite signs and are nearly equal.  
If not, repeat the work and correct the errors. There is no way of finding an error in such work except by repeating the work. A plus result shows the place at the end of the run to be higher, and a minus result, lower, than the starting place.

Add the rod readings, with their signs, in pairs, that were taken at each setting of the level, as  $+ 6.381$  and  $- 11.592$ , giving  $- 5.211$  as the distance the first T. P. is below the B. M. Enter these sums, with their signs, in columns, beside the rod readings that gave them, both going and returning. For convenient comparison the figures may be arranged as in the form. There may be found greater discrepancies in the figures showing the difference in elevation between the same two T. P.'s going, and returning, than appears for the entire circuit. In the form, the discrepancy for the circuit is  $1.764 - 1.760 = 0.004$ , while between the first and second T. P.'s the discrepancy is  $7.835 - 7.829 = 0.006$ . It may also be noticed that these discrepancies are in opposite directions. Such comparisons show the so-called "Closing error" of a leveled circuit to have only a general value, and that discrepancies in such work are compensating.

If it is impracticable to use the same T. P.'s, going and returning, the two lines of levels will have no connection except at their ends and the above comparison cannot be made.







University of Michigan.

Department of Engineering.

1909-9-9

Peg Levels. Short circuit

B. & B. Level 183.

Party      Sereus Skipper  
                  Active Trimmer

between U. S. Geol. Survey B. M. at Mech. Lab.  
 Univ. of Mich.

To find the difference in elevation  
 and top of watertable at West Hall,

B. M. to Watertable.      Watertable to B. M.

+S	-S	Peg to Peg.		+S	-S.
6.391					2.234
0.986	11.592	-5.211	+5.208	7.442	1.318
1.114	9.815	-7.829	+7.835	9.153	1.736
11.322	0.516	+0.598	-0.600	1.136	11.323
19.803	0.644	+10.678	-10.683	0.640	16.611
	21.567	-1.764	+1.760	18.371	

Returned on the same pegs.

On B. M.

On W. I.

1.762      Watertable below B. M.

Active Trimmer.



## VI. INTERSECTIONS AND CONNECTIONS.

### 59. Intersection of Two Straight Lines.

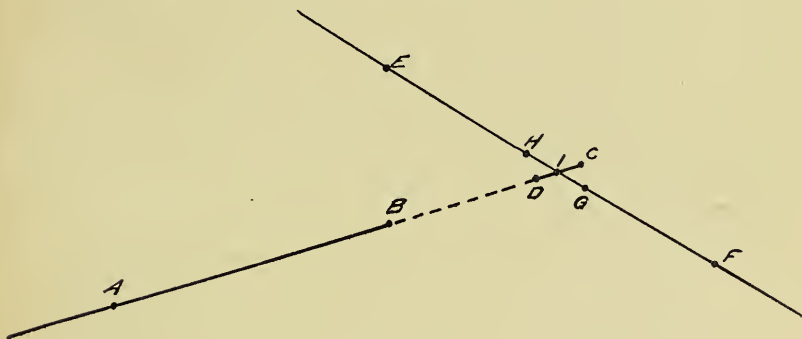

Lines given by plugs at A, B, E and F.

To find their intersection on the ground.

Set up the transit at B. Backsight to A. By the back and foresight reversion method locate two marks on each of two plugs at C, and D. Set C first, a little beyond where the line EF is supposed to pass. Set D on the other side of EF. Set both plugs at the same pointing of the telescope. Give line for first marks on both at one pointing. Give line for the second marks at one pointing, after the instrument has been reversed. This takes but about half the instrument work that would be required to set and mark each plug separately. Mark each plug by a third mark equidistant from the other two.

Move the transit and set it up at E. Stretch a string from C to D. Sight from E to F. By the foresight revision method locate two marks on each of the two plugs at G and H, one on each side of CD. Mark each plug by a third mark equidistant from the other two.

Stretch a string from G to H. Drive a fifth plug at the intersection of the two strings. Mark the intersection of the strings on the plug.

The above is the five plug method. It is useful when digging has to be done, as in looking for a landmark, or in setting a monument. The plugs C, D, G and H can be set back from the intersection far enough to be safe from disturbance. If digging is to be done, first mark the intersection, and measure its distance accurately from all four marks, C, D, G and H. Also measure CG, GD, DH and HC. Record all these measurements.

On rough ground it is easy to place the plugs C and D, first set, both on the same side of EF. After setting G and H, and marking them, the transit may be set up at C or D, and by sighting to B, one, or more, additional plugs can be set in the proper position with respect to GH.

The ground may be so rough that there will be difficulty in making the strings CD and GH touch. The fifth plug may be driven so as to receive the intersection by holding a plumb line so as to touch both strings when selecting the place for that plug. The line of each string may be transferred to the fifth plug, below the strings, by sighting past a plumb line and the string down to the top of the plug while an assistant marks two places, one on each edge of the plug, jointing the marks on the same range. Mark their intersection.

Should the ground be much higher at the intersection than at C, D, G and H, so strings cannot be stretched, set up the transit on C and sight to D, or better, to B, and mark a line on the ground for the fifth plug. Do the same on GH, with the transit. Mark GH on top of the plug after it is driven. Set up the transit again at C. Mark CD on the top of the plug. Mark the intersection of these lines on the plug.

The transit may be used in a similar manner to transfer the lines into a hole between C, D, G and H.

On comparatively smooth ground, and in many cases, three plugs are enough. After setting and marking C and

D, stretch a string on CD. Set up at E. Sight to F. Drive a third plug on EF and beneath the string CD. Mark this third plug on both edges of its top just as G and H were marked. Drive a nail at the intersection of the string with the line GH drawn on the top of the third plug this is the three plug method.

With the transit set up on each line a stake, plug, or an iron, can be driven at the intersection by taking line from both transits at once. To be nice about it a mark should be made at D, and H, near the intersection, so the line can be easily verified at almost any instant. The transit men should direct the driving of the stake, or iron, plumb.

After the intersection is found and marked, measure to it on both lines, AB and EF, and record these measurements. Set up the transit at the intersection and read, and record, the angle between the lines AB and EF, Unless these three items are obtained and recorded the work will be incomplete.

In general, it may be said that the intersection of any two lines is incomplete until the position of the intersection on both lines is ascertained by measurements, or distances, on those lines; the angle between the lines measured; and all the data recorded.

60. Connection of a point, P, with a straight line, AB.

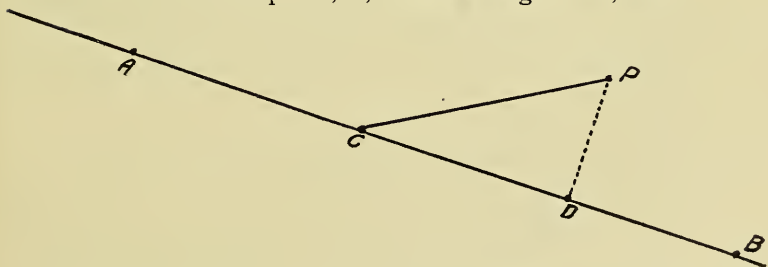

If practicable, set up the transit at some point, C, on the line AB, from which P can be seen. Read and record the angle ACP, or PCB. Measure and record the distance CP, and a distance to C on AB.

$$CD = CP \cos PCB.$$

$$PD = CP \sin ACP.$$

The coordinates of P with respect to AB thus become known. If P cannot be seen from any point on AB run a traverse C, E, F, P, from some point, C, the location of which on AB is known, making AB the reference line for this traverse. Compute the traverses of CE, EF, and FP. Sum these

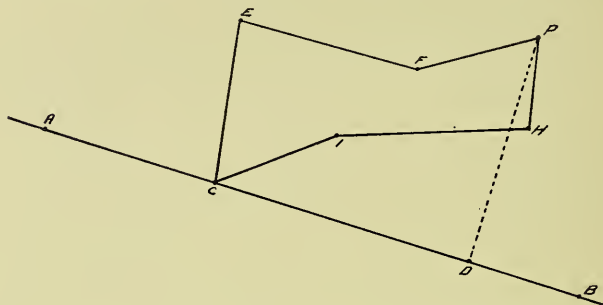

traverses. These sums will be the values of CD and DP, but with no check on the result. The sum of the sine traverses from C to P will be DP, and the sum of the cosine traverses from C to P, will be CD. If a check on the work is required, continue the traverse C, E, F, P, on round to H, I, and C, closing it. Compute the traverses of the closed figure. Sum these traverses. Correct the work, or balance the traverses, the same as in any closed survey. Compute the coordinates of E, F, P, H, and C. The coordinates of P will be  $x = DP$  and  $y = CD$ , from C as an origin.

#### 61. Connection of a point, P, with a circular curve, C.

Curve marked by equally spaced stakes.

If practicable set up the transit at some station, S, on the curve, from which P can be seen. Sight to a distant station, V, with the plates set at the readings for V. Release the plate clamp. Make a pointing on P using the plate clamp and slow motion screw. Read the plates. Record the readings. Release the plate clamp. Make a pointing on V using the plate clamp and slow motion screw. Read



the plates. Record the readings. See if the first and last readings agree. If not, repeat the work till they do. Measure the distance SP and record it.

If the position of P, with respect to the chord SV, is required, subtract the readings for V from the readings for P. The result will be the angle DSP, or  $360^\circ - \text{DSP}$ .

$$DP = SP \sin \text{DSP}$$

$$SD = SP \cos \text{DSP}$$

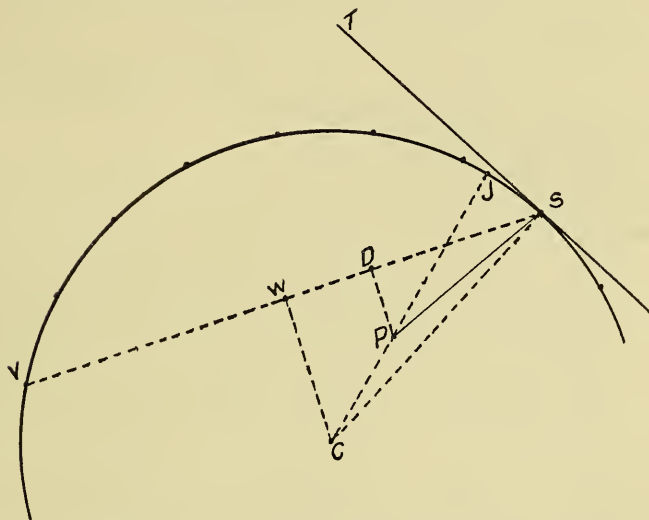

The difference between the readings for S and for V is the angle WCS.  $CS = R$ .

$$SW = R \sin \text{WCS}$$

$$CW = R \cos \text{WCS}$$

$$\text{Tan } \text{WCP} = \frac{SW - SD}{CW - PD}$$

$$CP = (CW - PD) (1 + \text{exsec } \text{WCP})$$

If CP be produced to meet the curve at J,

$$\text{JCS} = \text{WCS} \approx \text{WCP}.$$

Reading for J = readings for S  $\pm \frac{1}{2}$  JCS, according to which side of S, J comes, and whether the curve is running to the right or to the left.

If the position of P, with respect to the tangent ST, is required, subtract the readings for S from the readings for P. The result will be the angle PST, or its supplement. SP multiplied by the sine and cosine of PST will be the co-ordinates of P from S with respect to ST.

$$\text{Tan PCS} = \frac{\text{SP cos PST}}{\text{R} - \text{SP sin PST}}$$

Readings for J are then found as before.

P may be either side of CS and either inside or outside of the curve. All these details are not shown as they present no especial difficulty.

If P cannot be seen from any station or other point on the curve, lay out a tangent ST, or a radial line CS, on the ground. With one of these lines as a reference line connect P with S by means of a traverse, making it a closed traverse if the work requires it. Figure this traverse and compute the coordinates of P from S as directed in connecting a point with a line by traverse. Having the coordinates of P from S, the above computations can be made and the position of P, with respect to the curve, fully determined.

When the position of P with respect to the curve is determined any survey involving them can be made.

P can be made the center of a curve tangent to the given curve.

A circular curve can be passed through P and tangent to the given curve at any point.

The tangent point of a right line tangent to the given curve that will pass through P can be located, when P is outside of the given curve.

These are but examples of which there are more.

## 62. Connection of two straight lines.

When the lines cannot be intersected, join a point on each by a third line, or by a succession of lines.

Lines given by plugs at A, B, C and D.

To connect these lines by a survey, and get their relative position.

The given marks might ordinarily be connected, but the figure represents the case where other marks are used.

Locate the mark  $E$ , on  $AB$ , and the mark  $F$ , on  $CD$ , to be connected.

Connect  $E$  with  $F$  by a direct line if practicable. Measure  $EF$ , and the angles  $AEF$  and  $DFE$ . Also locate  $E$  on  $AB$

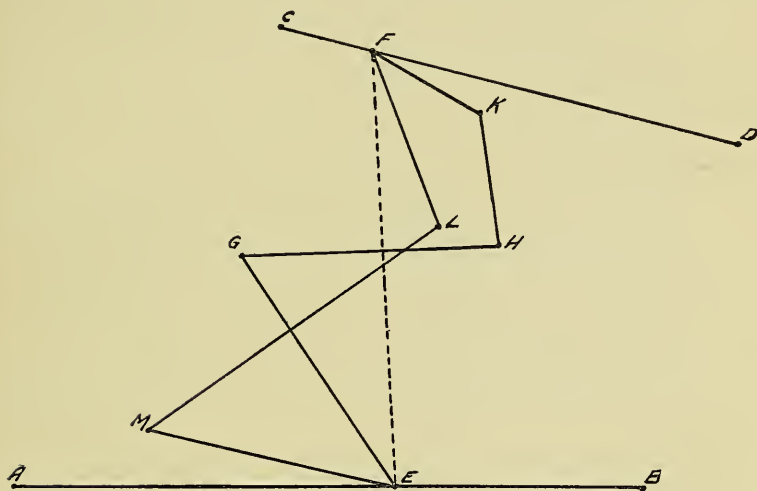

and  $F$  on  $CD$ , by measurement. Record all this information. Notice that a connection of this kind calls for five items,—three linear measurements and two angles.

When a direct line cannot be run, connect  $E$  with  $F$  by a succession of lines as  $EGHKF$ . Measure the angles at  $E$ ,  $G$ ,  $H$ ,  $K$  and  $F$ . Measure all lines. Measure the positions of  $E$  on  $AB$ , and of  $F$  on  $CD$ . Record all this in full. Notice that the number of angles is one more than the number of lines between  $E$  and  $F$ , and that the number of linear measurements is two more.

To add to the trustworthiness of the information repeat the

angles at E and F and all the linear measurements when the one line, EF, is used. To increase the trustworthiness of the work in the other cases repeat the work, or run a traverse from one line as AB, starting at E; thence to G, H, K, F,—at which place take readings on CD, repeated if necessary,—L, M, E., and to AB again, closing the traverse completely on that line. Record all these items.

Leave out the readings on AB and CD, and compute the traverses for the closed figure E, G, H, K, F, L, M, E. Balance the traverses, and compute the coordinates of the angles. From the coordinates of E and F, compute the traverse angle and length of EF. From the readings on AB and CD, and the traverse angle of EF find the angles AEF and EFD.

With the distance EF and the angles AEF and EFD, the positions of E on AB and of F on CD having been measured, the relative positions of AB and CD can be computed and thence problems relating to AB and CD, solved.

If  $\angle AEF = \angle EFD$ , AB and CD are parallel.

If  $\angle AEF > \angle EFD$ , AB and CD intersect toward D.

If  $\angle AEF < \angle EFD$ , AB and CD intersect toward A.

The Difference between  $\angle AEF$  and  $\angle EFD$  is the angle between AB and CD.

Let  $\angle AEF = E$ ;  $\angle EFD = F$ ;  $\angle AEF \sim \angle EFD = K$ .

Let  $EF = k$ ; the distance from E to the intersection of AB and CD =  $f$ ; and the distance from F to the intersection of AB and CD =  $e$ .

$e = \frac{k}{\sin K} \sin E$ ,  $f = \frac{k}{\sin K} \sin F$ ; and the proof equation is

$$ef = \frac{k^2}{\sin^2 K} \sin E \sin F$$

Having the distances from E and F to the intersection of AB and CD, and the angle between them, the data is in hand for solving any problem with respect to these lines. The connection is completed and computed.

## 63. Intersection of a straight line and a circular curve.

To find where a straight rail in a railway track intersects a rail of another, curved track, set up the transit on the gauge side of the straight rail and produce the line of the gauge side of that rail to intersect the gauge side of the curved rail. Mark this intersection. Measure and record the distance on the transit line to this intersection. Set up at this intersection. Measure from the intersection any number of station distances, or other equal distances, mark-

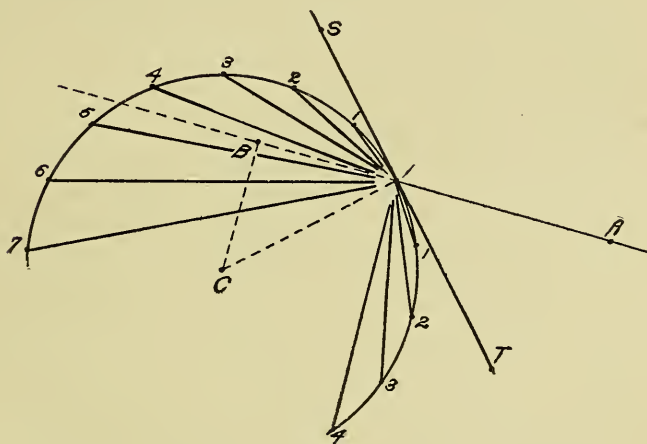

ing points, equally spaced, on the gauge side of the curved rail. Backsight along the straight transit line. Record the plate reading on this line. Release the plate clamp. By means of the plate clamp and slow motion screw take pointings and readings on all the equally spaced marks on the gauge side of the curved rail, recording the same, and make and record a final pointing and reading on the straight transit line as a check. Be careful to make a good record of all this information. The radius of the curved rail and the position of its center with respect to the straight rail can be computed.

Radius,  $R = \frac{1/2 c}{\sin d}$  where  $c$  is the chord used in spacing

the marks on the curved rail, and  $d$  is the average difference between the successive readings taken on those marks. Find the difference between the readings on the straight transit line and the reading to each of the equally spaced marks on the curved rail, to get the angles from the straight line to the chords from the intersection, above described, to each of the marks in succession. Subtract from, or add to, the first angle,  $d$ , the second,  $2d$ , the third,  $3d$ , and so on, obtaining values for the angle between the straight line and the tangent to the curve at their intersection. Take the average of these values for the angle,  $A$ , between said line and tangent.

If the upper marks in the figure are used,  $A = \text{convex AIS}$ , if the lower,  $A = \text{AIT}$ .

$$IB = R \sin A$$

$$CB = R \cos A$$

Having thus ascertained the relative positions of the two lines, various problems relating to them can be solved, such as joining these two rails by a curved rail tangent to them both or crossing either, or both, of them at a given angle.

If the curve is marked on the ground by the usual stakes, and not by a continuous line like a rail, the intersection of it by a straight line must be found in another way.

In some cases a tangent to the curve may be run, as  $OE$  from  $O$ ; intersected with the straight line  $AE$ , at  $E$ ; the distance  $OE$ , and the angle  $AEO$ , and the distance  $AE$ , measured and recorded.

$$\text{Let } E = AEO. \quad CB = R \cos E + OE \sin E.$$

$$\cos BCI = CB/R$$

$$ICO = E - BCI$$

$$I'CO = E + BCI$$

$$EOI = 1/2 ICO$$

$$EOI' = 1/2 I'CO$$

$$OI = 2R \sin EOI$$

$$OI' = 2R \sin EOI'$$

Or the plus distance from  $1$  to  $I$ , or from  $6$  to  $I'$ , can be computed and  $I$  located from  $1$ , or  $I'$  from  $6$ , the transit being at  $O$ . The line  $AE$  when extended should strike  $I$  or  $I'$ . Measure  $EI$  or  $EI'$ . Compute  $II' = 2R \sin BCI$ .

Check:  $-\overline{OE}^2 = \overline{EI} \times \overline{EI}'$ .

In case the tangent method cannot be used, connect some point, A, on the straight line AE, with O, and by taking the plate readings at O from OA to the successive stations on the curve ascertain the angle  $AOE = O$ . Measure AO,  $OAE = A$ , and the position of A on AE.

$$AEO = E = 180^\circ - (A + O)$$

$$CB = R \cos E + AO \sin A.$$

$$AE = AO \frac{\sin O}{\sin E} \quad OE = AO \frac{\sin A}{\sin E}$$

$$\cos BCI = BC/R$$

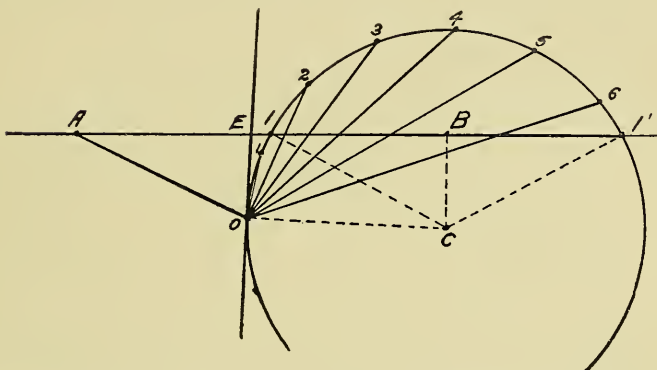

$$ICO = E - BCI$$

$$AOI = O + EOI$$

$$I'CO = E + BCI$$

$$AOI' = O + EOI'$$

$$EOI = \frac{1}{2} ICO$$

$$OI = 2R \sin EOI$$

$$EOI' = \frac{1}{2} I'CO$$

$$OI' = 2R \sin EOI'$$

Or the plus distance from 1 to I, or from 6 to I', can be computed and I located from 1, or I' from 6, the transit being at O.

The line AE produced should strike I or I'.

Measure AI or AI'. Compute  $II' = 2R \sin BCI$ .

Find  $EI = AI - AE$ , and  $EI' = AI' - AE$ ,

$$EI' - EI = II' \text{ as before.}$$

Check:  $-\overline{OE}^2 = \overline{EI} \times \overline{EI}'$

**64. Connection of a straight line and a circular curve which do not intersect.**

In some cases a radial line, as  $OF$  from  $O$ , perpendicular to the tangent  $OE$ , can be run; intersected with the straight line  $AE$ , at  $F$ ; the distances  $AF$  and  $OF$ , and the angle  $OFE = F$ , measured and recorded.

$$FB = (R + OF) \cos F. \quad CB = (R + OF) \sin F.$$

Having  $FB$  and  $CB$ , the relations of the circular curve and the straight line become known, and various problems relating to them can be solved.

$BCF = 90^\circ - F$ , and the point  $G$ , on the curve, nearest to  $AE$  can be located. Measure  $GB$ . See if it equals  $CB - R$ .

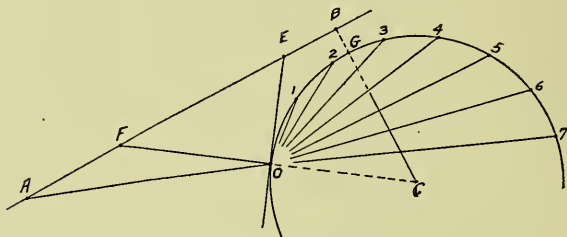

Sometimes the tangent at  $O$ , as  $OE$ , can be run; intersected with  $AE$ , at  $E$ ; the distances  $AE$  and  $OE$ , and the angle  $AEO = E$ , measured and recorded.

$$EB = OE \cos E - R \sin E. \quad CB = OE \sin E + R \cos E.$$

In case neither of the above methods can be used, connect some point,  $A$ , on the straight line  $AE$ , with  $O$ , and by taking the plate readings at  $O$  from  $OA$  to the successive stations, or equally spaced marks on the curve, get the angle  $AOE = O$ . Measure and record  $OA$  and  $OAE = A$ .

$$E = 180^\circ - (A + O)$$

$$AB = R \sin E + AO \cos A. \quad CB = R \cos E + AO \sin A.$$

**65. Intersection of two circular curves.**

Both may be marked by stations, or one by a continuous line, as a rail. Because the position of the intersection,  $I$ ,



should be verified by angle and distances, both curves will be regarded as marked by stations, or some system of equally spaced marks, the latter to be used on a rail.

Join  $A_1$ , some mark, or station, on the curve,  $C_1$ , with  $A_2$ , some mark or station, on the curve  $C_2$ . Set up the transit at  $A_1$ . Take readings on  $A_2$ , on 1, 2, 3, 4, etc. on the curve  $C_1$ , and back on  $A_2$ . Make a full and careful record of these readings. Move the transit and set it up at  $A_2$ . Take and record as before, readings on  $A_1$ , on 1, 2, 3, 4, etc. on the curve  $C_2$ , and back on  $A_1$ . Measure and record  $A_1A_2 = k$ . As  $A_1A_2$  is the reference line for the work it

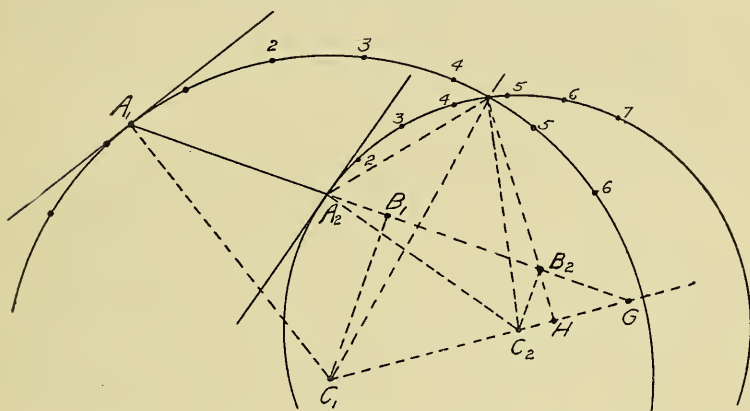

should be as long as practicable, and  $A_2$  be taken at station 10, or a similar station, on curve  $C_2$ , to accomplish this.

From the readings at  $A_1$  and the distance from  $A_1$  to 1, 1 to 2, 2 to 3, etc. compute the radius,  $R_1$ , of the curve  $C_1$ . From these readings and those on  $A_2$  find the angle  $EA_1A_2 = A_1$ .

From the readings at  $A_2$ , and the distance  $A_2$  to 1, 1 to 2, 2 to 3, etc. on curve  $C_2$ , compute the radius,  $R_2$ , of this curve. From these readings and those on  $A_1$  find the angle  $FA_2A_1 = A_2$ .

If  $A_1A_2$  is on the concave side of the curve, as at  $A_1$ , the angle  $A_1$  must be reckoned to the inside of the tangent  $A_1E$ .

If  $A_1A_2$  is on the convex side of the curve, as at  $A_2$ , the angle  $A_2$  must be reckoned to the outside of the tangent  $A_2F$ .

The angles  $A_1$  and  $A_2$  will both be reckoned to the outside of the tangents at  $A_1$  and  $A_2$  when  $A_1A_2$  lies outside of both curves. As they may be reckoned from either side of  $A_1A_2$ , there will be four ways in which they may be taken, only two of which are correct.

These angles will both be reckoned to the inside of the tangents when  $A_1A_2$  meets both curves on the concave side. There will be four ways of taking them, as before, only two of which are correct. There are four ways of taking them in the figure, only two of which are correct. It is therefore necessary to carefully observe the directions.

If  $A_1$ , or  $A_2$ , is reckoned to the inside of the tangent, as at  $A_1$ , find,

$$K_1 = 90^\circ - A_1 \text{ or } K_2 = 90^\circ - A_2, \text{ for } A_1 \text{ or } A_2 < 90^\circ.$$

$$K_1 = A_1 - 90^\circ \text{ or } K_2 = A_2 - 90^\circ, \text{ for } A_1 \text{ or } A_2 > 90^\circ.$$

If  $A_1$ , or  $A_2$ , is reckoned to the outside of the tangent, as at  $A_2$ , find,

$$K_1 = 90^\circ + A_1 \text{ or } K_2 = 270^\circ - A_2, \text{ for } A_1 \text{ or } A_2 < 90^\circ$$

$$K_1 = 270^\circ - A_1 \text{ or } K_2 = 270^\circ - A_2, \text{ for } A_1 \text{ or } A_2 > 90^\circ.$$

If  $A_1$  is reckoned to the inside of the tangent, and  $A_2$  to the outside, as in the figure, find the corresponding values of  $K_1$  and  $K_2$  in the above groups. Similarly for the reverse case.

In the figure  $K_1 = A_2A_1C_1$ , and  $K_2 = A_1A_2C_2$ .

$$\text{Find } \tan A_1GC_1 = \tan \beta = \frac{R_1 \sin K_1 - R_2 \sin K_2}{k - R_1 \cos K_1 - R_2 \cos K_2}$$

Observe all signs.

$$C_1C_2 = a = (k - R_1 \cos K_1 - R_2 \cos K_2) (1 + \text{exsec } \beta)$$

$$N_1 = A_1C_1C_2 = 180^\circ - (\beta + K_1) \text{ for } R_1 \sin K_1 > R_2 \sin K_2.$$

$$N_2 = A_2C_2C_1 = 180^\circ - (K_2 - \beta) \text{ for } R_1 \sin K_1 > R_2 \sin K_2.$$

$$N_1 = A_1C_1C_2 = 180^\circ - (K_1 - \beta) \text{ for } R_1 \sin K_1 < R_2 \sin K_2.$$

$$N_2 = A_2 C_2 C_1 = 180^\circ - (\beta + K_2) \text{ for } R_1 \sin K_1 < R_2 \sin K_2.$$

$$\text{Check: } -N_1 + N_2 + K_1 + K_2 = 360^\circ.$$

In the triangle  $C_1 C_2 I$ , compute all the angles.

$$s = \frac{1}{2} (R_1 + R_2 + a). \quad \text{Tan } \frac{1}{2} I = \sqrt{\frac{(s - R_1)(s - R_2)}{s(s - a)}} \\ \cdot I =: C_1 I C_2.$$

$$\text{Tan } \frac{1}{2} C_1 = \sqrt{\frac{(s - R_1)(s - a)}{s(s - R_2)}} \quad C_1 = I C_1 C_2.$$

$$\text{Tan } \frac{1}{2} C_2 = \sqrt{\frac{(s - R_2)(s - a)}{s(s - R_1)}} \quad C_2 = I C_2 C_1.$$

$$\text{Check: } -\frac{1}{2} I + \frac{1}{2} C_1 + \frac{1}{2} C_2 = 90^\circ.$$

$$\frac{1}{2} N_1 - \frac{1}{2} C_1 = \frac{1}{2} A_1 C_1 I. \quad \frac{1}{2} C_2 - \frac{1}{2} N_2 = \frac{1}{2} A_2 C_2 I.$$

$$\text{Chord } A_1 I = 2R_1 \sin \frac{1}{2} A_1 C_1 I$$

$$\text{Chord } A_2 I = 2R_2 \sin \frac{1}{2} A_2 C_2 I$$

With  $\frac{1}{2} A_1 C_1 I$  the readings for  $I$  from  $A_1$  can be found, and the short chord from  $4$  to  $I$  computed. The intersection,  $I$ , can then be located with respect to the curve  $C_1$ , with the transit at  $A_1$ , using the long chord,  $A_1 I$ , or the short chord from  $4$  to  $I$ . Or the transit can be set at any station, by using the short chord from  $4$  to  $I$ .

With  $\frac{1}{2} A_2 C_2 I$  the readings for  $I$  from  $A_2$  can be found and the short chord from  $4$  to  $I$  computed for the curve  $C_2$ . The intersection  $I$ , can then be located with respect to this curve.

The two locations should give the same mark at  $I$ . Set up the transit at  $I$ . Take readings to the marks, 1, 2, 3, 4, etc., on both curves, using the same backsight, say  $A_1$ . From these readings get the angle between the tangents to both curves at  $I$ . See if this equals  $I$ , as computed above, or  $180^\circ - I$ .

If the checks indicate erroneous work, review it and correct the errors.

66. **Connection of two circular curves which do not intersect.** Make the connection as in the previous case, taking the same readings, making the same measurements, records and computations. By this process the angles  $A_1$ ,  $A_2$ ,  $K_1$ ,  $K_2$ ,  $N_1$ , and  $N_2$  and the radii  $R_1$ , and  $R_2$  are found; the distance,  $k = A_1A_2$  is measured; and  $C_1C_2 = a$ , computed. With these quantities known, problems relating to the two curves can be solved.

If the common external tangent,  $T_1T_2$ , is required it may be located as follows:

$$\text{Find } \sin S = \frac{R_1 - R_2}{a}$$

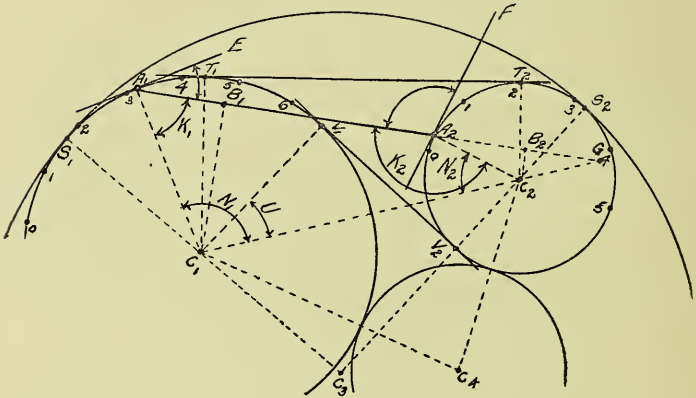

$$T_1T_2 = a \cos S.$$

$$A_1C_1T_1 = N_1 - 90^\circ + S. \quad A_2C_2T_2 = 90^\circ + S - N_2.$$

Locate  $T_1$  and  $T_2$  by means of these last angles; the radii,  $R_1$  and  $R_2$ , and the necessary calculated quantities. Measure  $T_1T_2$ , and see if it equals the above computed value.

For the internal common tangent  $V_1V_2$ , find

$$\cos U = \frac{R_1 + R_2}{a}$$

$$V_1V_2 = (R_1 + R_2) \tan U = a \sin U.$$

$$A_1C_1V_1 = N_1 - U. \quad A_2C_2V_2 = N_2 + U.$$

Locate  $V_1$  and  $V_2$  by means of these last angles, the radii,  $R_1$  and  $R_2$ , and the necessary calculated quantities. Measure  $V_1V_2$  and see if it equals the computed value.

For circular curve tangent to the two given curves. Assume its radius,  $R_3$ . Find the sides and compute the angles in the triangle  $C_1C_2C_3$ .

$$A_1C_1S_1 = 180^\circ - N_1 - C_1. \quad A_2C_2S_2 = 180^\circ - N_2 - C_2.$$

With these angles locate  $S_1$  and  $S_2$ .

## VII. PASSING OBSTRUCTIONS.

### 67. Passing Small Objects on a Straight Line by Similar Triangles.

#### Alignment.

With the transit set up at B, locate E in the line a little way from the object. Take points F and G at equal distances from E on lines making such equal angles with AB that they will pass the object. Locate H and L on BL and beyond the object, taking L as far away as convenient. Locate K and M so that  $FK = GH$  and  $KM = HL$ . Find P and N, or R and Q, equidistant from H and K, and L and M. Find, if necessary,  $BP = BK \cos KBP$ .

Seek to get G and F in such positions that they may be used instead of H and K. This may be done by making the

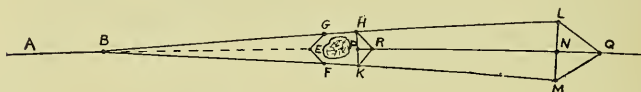

angles at B sufficiently large. The angles at B should always be small. In laying off the angles if the telescope is reversed about the transit axis the instrument should be reversed after laying off the first angle and before laying off the second. If this is done the error of adjustment will be practically eliminated from the work. Since the sines of angles are proportional to the angles to four places of decimals up to  $2^\circ$ , the results of this method may be easily tested in any case.

The sine of one minute is .0002909. Therefore  $HK = .00058 BK$  times the number of minutes in  $KBP$ .  $LM$  may be found similarly. It may be noticed that the location of two points beyond the object requires no figures at all. In measuring the distance  $EG$  and  $EF$ , as also the other distances that admit of it, use a stick with blazed ends and a pencil mark on each end. This will insure *equality* of the distance.

68. Passing an Object on a Straight Line by Triangulation. Measurement.

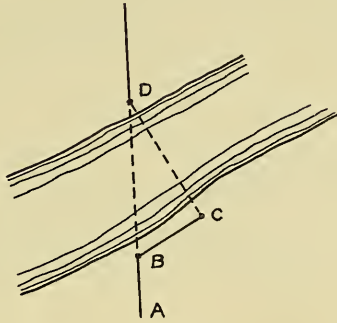

Take a point B in AB a little distance from the object. Take a second point, D, in the line produced beyond the object so that a third point, C, not in AB, can be seen from B and D. Choose C. Measure BC, DBC and BCD. Move the instrument to D. Measure BDC. Compute  $180^\circ = \text{BCD} + \text{BDC} + \text{DBC}$ .

$$\text{Also } BD = \frac{BC \sin BCD}{\sin BDC}.$$

If DBC be taken  $60^\circ$ , BCD  $90^\circ$ , and D located at the intersection of AB and CD,  $BD = 2BC$ . C may be taken on either side of the object.

69. Passing an Object on a Straight Line by Transversals. Measurement.

Let the object be one that cannot be measured round. Set out the work as indicated in the figure, if possible, making  $BC = \text{one-sixth of the estimated value of } CH$ ,  $BCD = 90^\circ$ ,  $CBD = 60^\circ$  and the triangle DGE equal in every respect to the triangle BCD. Locate H at the intersection of AC and EG. Find  $CH = 6.464 = 2BG - BC$ . Check:—  $BD = DE = 1.155$  ( $CD = DG$ ). This test can be applied to these triangles when laid out.

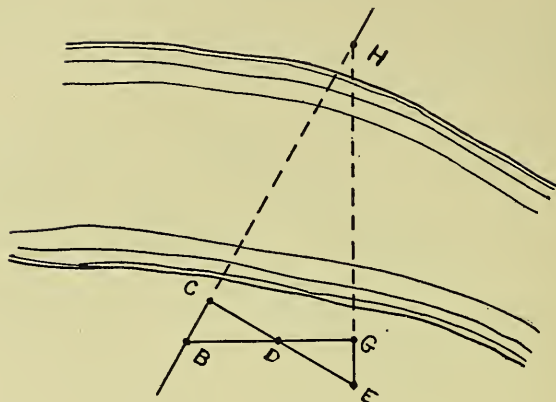

70. Passing an Object on a Straight Line by Approximate Length of Circular Arc. Measurement.

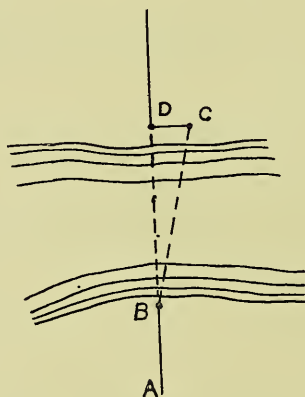

Let the object be one that cannot be measured round. Locate a mark, B, in AB near the object, and a mark, D, in AB, beyond the object. Set up the instrument at B. Turn off some small angle,  $DBC = \theta$ , and locate a mark, C, on one side of BD so that BDC is an estimated right angle. Or make  $BDC = 90^\circ$  with the chain. Measure DC precisely with a tape, a rule, or with the level rod if it is handy.



$$\text{Compute } BD = \frac{DC}{\theta^\circ} 57.296.$$

The notation  $\theta^\circ$  signifies that the angle  $\theta$  is to be used in degrees and decimals of a degree. This method is considered as accurate as ordinary chaining when  $BD$  is less than  $600'$  and  $\theta$  is read to minutes. The angle  $DBC$  should not exceed  $1^\circ 30'$  and  $DC$  should be but a few feet and very carefully measured. When possible take  $DBC$  some simple fraction of  $1^\circ$ .

### 71. Passing an Object on a Straight Line with the Instrument Alone.

Alignment.

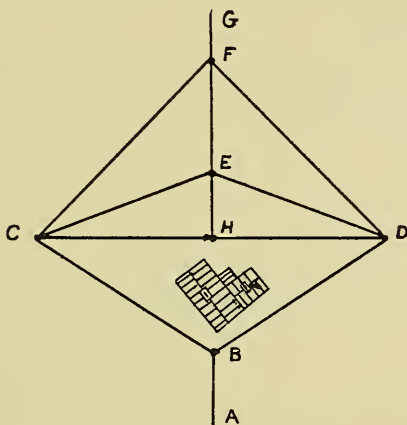

Set up the instrument at  $B$ . Locate  $BC$  and  $BD$ , lines making such equal angles with  $AB$  that they will pass the object. Mark a point,  $C$ , in  $BC$  so that  $CD$ , perpendicular to  $AB$ , will pass the object. Also mark two points in  $BD$  near the estimated position of  $D$ , preparatory to finding the intersection of  $CD$  and  $BD$ , if possible before moving the instrument from  $B$ . Move the instrument to  $C$ . Turn off  $BCD = ABC - 90^\circ$  and mark two points near  $D$  for finding the intersection of  $CD$  and  $BD$ . Start the lines

CE and CF towards AB produced, measuring and recording BCE and BCF. If possible mark points in these lines near E and F for intersection purposes. Find and mark D, the intersection of CD and BD. Set up the instrument at D. Turn off  $BDE = BCE$  and  $BDF = BCF$ . Find and mark E and F at the intersections of CE and DE, and of CF and DF.

Check:—Measure FEC or CFE.  $BCE + HBC = FEC + CFE = ABC - BCF$ . Also CFE should equal DFE and  $CEF = DEF$ .

In turning off the first angles use ABC and ABD and not HBC and HBD if starting from a backsight towards A. A number of points may be located in a similar manner to that given for E and F. They should lie in the same straight line.

## 72. Passing an Object on a Straight Line by Using Natural Tangent of $0^\circ 34'$ .

Distance.

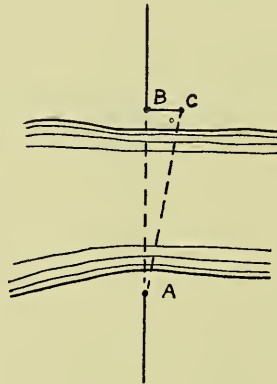

Set up the instrument at A. Locate a mark, B, on the line beyond the object. Turn off  $0^\circ 34'$  either way from AB and locate a mark, C, making ABC an estimated right angle. Measure BC to hundredths. Multiply this distance by 101 and add .1 for every hundred in the result.

Example:—BC measures 9.89.

$$\begin{array}{r}
 989 \\
 989 \\
 \hline
 998.89 \\
 1.00 \\
 \hline
 999.89
 \end{array}$$

This shows an error of 0'.11 in 1000'.

Care must be taken in laying off the angle and in reading the distance, as a difference of 0'.01 in the length of BC makes a difference of 1'.01 in the result, no matter what the length of AB may be.

## VIII. CIRCULAR CURVES WITH STEEL TAPES.

### 73. Notation.

- P. I. = Point of intersection of the tangents.  
P. C. = Point of curvature, or beginning of curve.  
P. T. = Point of tangency, or end of curve.  
 $\Delta$  = The angle subtended by the curve, or the angle between the tangents.  
R = The length of the radius of the curve.  
T = The length of the tangents, or the distance from the P. I. to P. C., or from P. I. to P. T.  
D = The angle at the center of the curve subtended by a chord, the length of which is a station distance, or  $D$  = the degree of the curve.  
 $c$  = The chord the length of which is a station distance.  
 $c_0$  = The length of the short cord preceding P. C. on the curve produced backward.  
 $c_1$  = The length of the short chord following P. C. on the curve.  
 $c_2$  = The length of the short cord preceding P. T. on the curve.  
 $c_3$  = The length of the short chord following P. T. on the curve produced.  
 $t$  = The tangent offset for a station distance.  
 $2t$  = The chord offset for a station distance.  
 $t_0$  = The tangent offset for a distance  $c_0$ .  
 $t_1$  = The tangent offset for a distance  $c_1$ .  
 $t_2$  = The tangent offset for a distance  $c_2$ .  
 $t_3$  = The tangent offset for a distance  $c_3$ .  
 $d$  = The angle at the center of the curve subtended by  $c$ .  
 $d_0$  = The angle at the center of the curve subtended by  $c_0$ .  
 $d_1$  = The angle at the center of the curve subtended by  $c_1$ .  
 $d_2$  = The angle at the center of the curve subtended by  $c_2$ .  
 $d_3$  = The angle at the center of the curve subtended by  $c_3$ .  
 $a$  = The length of the chord offset for a distance  $c_2$ .

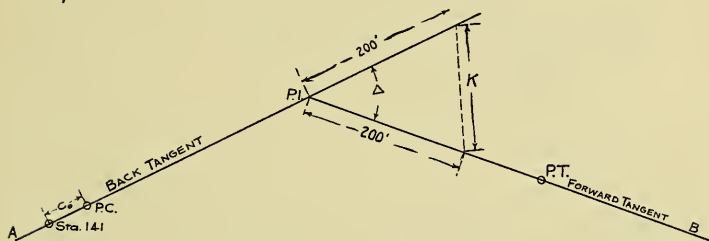
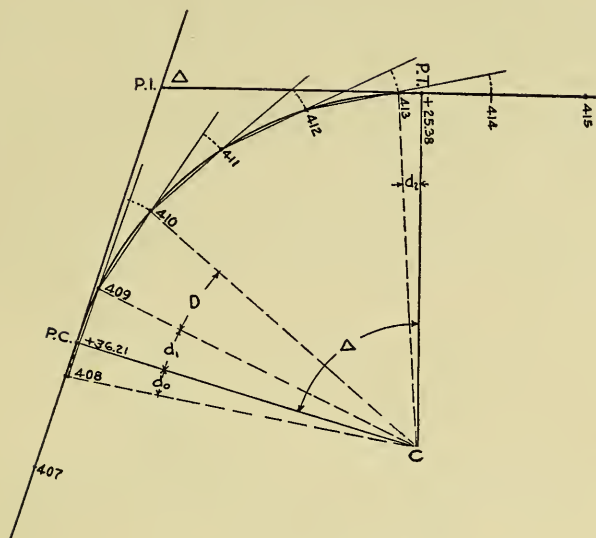

Decide upon a site for P. I. Mark this point by a nail in a stake. Witness this point.

Assume the direction of the tangents and mark a point on each by a nail in a stake.

Measure from P. I. along the back tangent produced 200'.

Mark the end of this distance. Measure from P. I. along the forward tangent 200'.

Mark the end of this distance. Measure between the two points last set. Call this distance k.

Find  $\Delta/2$  by  $\sin \Delta/2 = k/400$ , and

$$T = R \tan \frac{\Delta}{2}$$

Assume  $D$  to give curve of desired length, and find  $R$  in Table IV, Searle's.

Measure from P. I. along the forward tangent a distance  $T$  and mark the end of this distance by a nail in a stake. Witness this point. Call this P. T. Be sure to get this point exactly on line.

Measure from P. I. along the back tangent a distance  $T$  and mark the end of this distance by a nail in a stake. Witness this point. Call this P. C. Be careful to get it exactly on line.

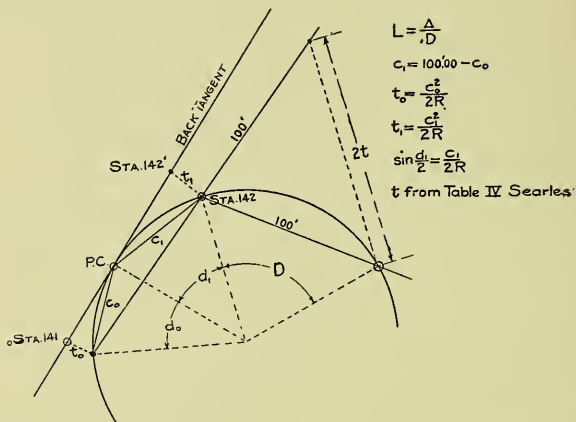

Mark a point on the back tangent less than 100' beyond the P. C. from P. I. by a nail in a stake. Call this a regular station on the line and give it a number as 141. Measure the distance from this point to P. C. This =  $c_0$ .

Compute  $c_1$ ,  $t_0$ , and  $t_1$ .

With sta. 141 and P. C. as centers and  $t_0$  and  $c_0$  as radii, strike arcs intersecting on the inside of the tangent. Mark this point accurately. Call it sta. 141'.

Measure forward from P. C. along the tangent a distance  $c_1$  =  $100' - c_0$ . At the end of this distance mark a point exactly on line. Call this sta. 142'.

With P. C. and sta. 142' as centers, and  $c_1$  and  $t_1$  as radii, strike arcs intersecting inside the tangents. Mark this intersection by a nail in a stake. This is sta. 142.

Produce the line through sta. 141' and sta. 142 for a distance = one station (100') beyond sta. 142 . Mark a point here . Call it sta. 143' .

With sta. 142 and 143' as centers, and 100' and 2t as radii, strike arcs intersecting on the side away from the tangents. Mark this point by a nail in a stake. This is sta. 143 .

Produce a line through sta. 142 and sta. 143 for 100' beyond sta. 143 . Mark this point . Call this sta. 144' . With sta. 143 and sta. 144' as centers, and 100' and 2t as radii, strike arcs intersecting on the side away from the tangent. mark this point by a nail in a stake. This is sta. 144 .

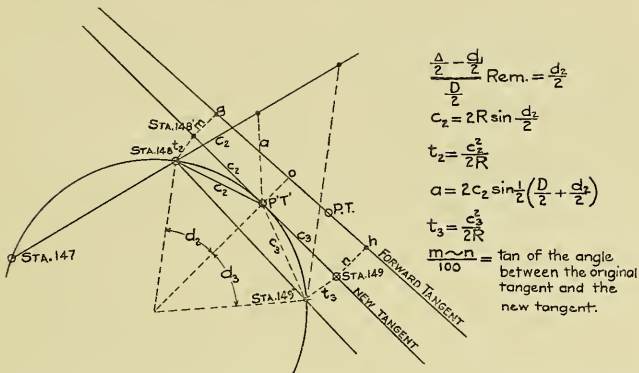

Continue in this manner until one station beyond P. T. is set.

Call the last station preceding P. T. 148 .

Measure forward from sta. 148, along the chord from sta. 147 through sta. 148, a distance  $c_2$ . Mark this point .

With sta. 148 and point last set as centers, and  $c_2$  and  $a$  as radii, strike arcs intersecting on the side away from the tangent . Mark this intersection with a nail in a stake. This is P'T' .

With P'T' and sta. 148 as centers, and  $c_2$  and  $t_2$ , as radii, strike arcs intersecting on the side toward the tangent. This intersection will be another point on the new tangent through P'T' . With P'T' and sta. 149' as centers and  $C_3$  and  $t_3$  as radii strike arcs intersecting on the side towards the tangent. This intersection will be another point on the new tangent through P'T' . The two points last set and P'T' should lie on a straight line.

If the work could be accurately done the new tangent and the original one would coincide, as would also P. T. and P'T'.

To get the angle between the original tangent and the new one, measure the perpendicular distance between the two at sta. 148' and at sta. 149'. If these latter points are on the same side of the original tangent find the difference between them and divide it by one hundred.

This gives the natural tangent of the angle.

If the two points are on opposite sides of the original tangent, divide their *sum* by one hundred.

Find also the distance P'T' is inside or outside of the original tangent, and how far back, or ahead, of P. T., P'T' comes.

Make a complete record of all these items in the order in which the different parts were done.

The lining in can be best done by using two plumb bobs and a line staff. Always have the line staff marking the point farthest away from the eye.

At the P. C. and P. T. witness, or reference, stakes should be set.

These should be about 1' x 2' x 2'.5, and should be driven about one foot to the side of the hub which marks the P. C. or P. T., facing the hub, and with the top slightly inclined away from it. On the face of the stake should appear the station and plus of the hub, the letters P. C. or P. T., and L or R according as the curve is to the right or left. On the reverse side should appear the degree of the curve and the value of  $\Delta$ .



© 141+63.84  
P.C.R.

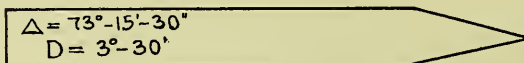

$\Delta = 73^{\circ}-15'-30''$   
D = 3°-30'



## IX. CIRCULAR CURVES WITH THE TRANSIT.

### 74. Notation.

The same as in the circular curve with steel tapes and

$K$  = the middle point of the curve

$E$  = the distance from P. I. to  $K$

$c_k$  = the length of the short chord preceding  $K$

$d_k$  = the angle at the center of the curve subtended by  $c_k$

### 75. Directions.

Decide upon a site for P. I. Mark this point by a nail in a stake. Witness this point.

Assume the direction of the tangents and mark a point on each by a nail in a stake.

Set the transit up at P. I. and measure the angle P. C. — P. I. — P. T. =  $180^\circ - \Delta$ . Record in the usual way.

Assume  $D$  to give a curve of the desired length, and compute  $T$  as in the previous case.

Measure from P. I. along the forward tangent a distance  $T$  and mark the end of this distance by a nail in a stake.

Witness this point. Call this P. T.

Compute  $E = T \tan \Delta/4$ .

Measure from P. I. along the bisector of the angle P. C. — P. I. — P. T. a distance  $E$ . Mark the end of this distance by a nail in a stake. Call this point  $K$ .

Measure along the back tangent a distance  $T$ , from P. I., and mark the end of this distance by a nail in a stake.

Witness this point. Call this P. C.

Mark a point on the back tangent less than 100' beyond P. C. from P. I. by a nail in a stake. Call this a regular station on the line and give it a number, as 141.

Measure the distance from this point to P. C. 100' minus this distance =  $c_1$ .

Compute  $\sin d_1/2 = c_1/2R$ , and find  $d_1/2$  in the tables.

Compute  $\frac{\Delta/4 - d_1/2}{D/2}$ . The remainder =  $d_k/2$ .

$$c_k = 2R \sin d_k/2$$

$$\frac{\Delta/2 - d_1/2}{D/2}. \text{ The remainder} = d_2/2.$$

$$c_2 = 2R \sin d_2/2.$$

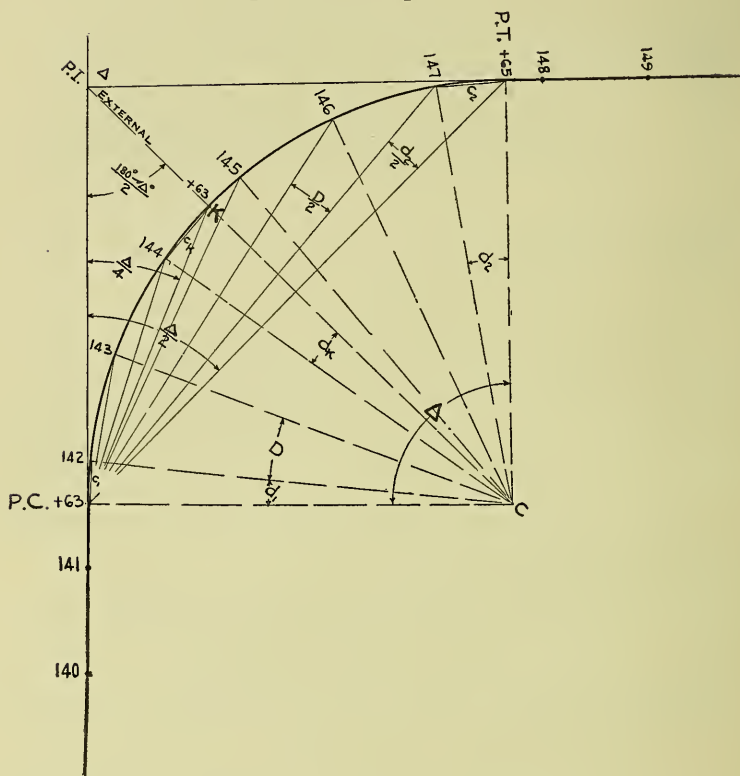

The plate readings for the P. C. will be  $0^{\circ}00'00''$  on Ver. A, and  $180^{\circ}00'00''$  on Ver. B. For the plate readings for the next station add  $d_1/2$  to the reading of each vernier. Add to these  $D/2$  for the readings for the next station, and so on until the readings for the station preceding K have been found.

To find the plate readings for K, add to the readings for the last station preceding it,  $d_k/2$ . Add  $D/2$  to the readings for the station preceding K, to find the readings for the

station following K. By adding  $D/2$  for each station distance find the readings for the stations preceding P. T. To the readings for the last station preceding P. T. add  $d_2/2$  to find the readings for P. T.

The reading for Ver. A for K should  $= \Delta/4$ , and that for P. T. should  $= \Delta/2$ .

Set the transit up at P. C. Set the plates to read  $0^\circ 00' 00''$  and  $180^\circ 00' 00''$ . Set the line of sight on P. I. Release the plates. Set the plates at the readings for the first station on the curve.

Measure from P. C. along the line thus indicated the length of the first short chord  $= c_1$ . Mark this point by a nail in a stake. The stake should bear the number of the station, and a line mark, if necessary.

Lines are often designated by letters, as Line L.

Release the plates and set them at the readings for the next station. Measure forward from the station just set  $100'$  and set a station on the line of sight, marking as before.

Continue in this manner around the curve. Note in the field Note book the check at K and at P. T.

If considerable time is consumed in running the curve, backsights should be taken from time to time upon P. I. to be sure that the instrument is steady. If the levels show disturbance, level up and backsight before setting any more points.

If for any reason it becomes necessary to move up on the curve, that is, to move the transit forward along the curve, be especially sure that the point to which it is moved is correctly set.

Move the transit and set it over the new point. Backsight to any other point on the curve *with the plates set at the readings for the point sighted to.*

Continue setting points on the curve using the plate readings as prepared if the points to be set are on the same side of the transit as the backsight. If the points to be set are on the opposite side of the transit from the backsight, exchange the vernier readings.

Care should be exercised to see that the same tension is applied to the tape at all times.

UNIVERSITY OF MICHIGAN

1909—XI—18.

Practice survey:—Laying out a Circular Curve with  
Transit.

Location:—Hamilton Park, Ann Arbor, Mich.

Decide upon a site for P. I. and mark it by a nail in a stake  
driven flush with the ground near the house occupied  
the Keystone Club. Witnesses:—

Elm 6" S 45° ?E, 70.56 to center  
Elm 5" N 80° ?E, 42.37 to center  
Soft Maple 4" N'y, 72.40 to center  
S. E. corner of ice-house S. 60° ?W., 25.93

Assumed direction of tangents and marked  
a point on each by a nail in a stake.

At P. I.

Ver. A.	Ver B.		
273° 38' 30"	93° 38' 30"	38' 30"	
73° 39' 30"	253° 39' 30"		39' 30"
273° 38' 30"	93° 38' 30"	38' 30"	<u>38' 30"</u>
		180° — Δ =	160° 01' 00"

672.'96 Measured along forward tangent 672.'96.

Marked the end of this distance by a nail in a stake. Ca  
this point P. T. Witnesses:—

Elm 7" N 10° ?E 25.'28 to center  
Tel. pole 12" N 40° ?W 32.'86 to center  
Elm 11" N 50° ?E 102.'14 to center  
Fence post 4" S 5° ?E 48.'39 to center

# DEPARTMENT OF ENGINEERING

Instruments:—  
 Transit No. 8333  
 100' Tape No. XX.  
 50' Tape No. 21.

Part:— II.  
 H. L. Wright  
 R. R. Roem  
 H. C. Walker  
 C. W. Wright

1g back tangent	180°00'00"
1g forward tangent	160°01'00"
1g back tangent	<u>19°59'00" = Δ</u>

le  
 $\Delta/2 = 9^{\circ}59'30''$                        $\Delta/4 = 4^{\circ}59'45''$

Assumed D = 1°30'00"

T = R tan Δ/2 .                      E = T tan Δ/4

$\Delta/2 = 9^{\circ}54'30''$	log tan	9.249491			
R = 3819.'83	log	R = <u>3.582044</u>			
T = 672.'96	log	T = <u>2.827993</u>			
$\Delta/4 = 4^{\circ}59'45''$	log tan	<u>8.941587</u>			
E = 58.'83	log	E = <u>1.769580</u>			

# UNIVERSITY OF MICHIGAN

1909-XI-18.

Practice Survey:—Laying out a Circular Curve with the Transit.

Location:—Hamilton Park, Ann Arbor, Mich.

at P. I.

Ver. A.	Ver. B.		
338° 54' 30"	158° 54' 30"	54' 30"	N'ly to P. T.
55° 55' 00"	238° 55' 00"		55' 00" E'ly along
338° 54' 30"	158° 54' 30"	54' 30"	54' 30" N'ly to P. T.
<hr style="width: 20%; margin: 0 auto;"/>			
80° 00' 30"			N'ly angle.

58.'83 Measured along external 58.'83 from P. I. and set

672.'96 Measured along back tangent 672.'96. Marked

Witnesses:—

Elm 5" W'ly 123.'17 to center.

Apple 5" S 80° ?W 121.'34 to center.

Maple 28" S 65° ?E 251.'37 to center.

Maple 6" N'ly 120.'62 to center.

Set a nail in a stake on tangent less than 100' beyond P. I. sta. 100.

43.'45 Measured from sta. 100 to P. C. 43.'45 =  $c_0$ .

Made up plate readings as follows:

DEPARTMENT OF ENGINEERING.

Instruments:—  
 Transit No. 8333.  
 100' Tape No. XX.  
 50' Tape No. 21.

Party:—II.  
 R. R. Roem.  
 H. C. Walker.  
 H. L. Wright.  
 C. W. Wright.

ernal to set K.

$$\frac{180^\circ - \Delta}{2} = 80^\circ 00' 30''$$

arked K by a nail in a stake.

of this distance by a nail in a stake. Called this point P. C.

in P. I. to mark last regular station on tangent. Called this

$$100.00 - c_0 = 56.55 = c_1. \quad \sin d_1/2 = c_1/2R.$$

$$\begin{array}{rcl} c_1 & = & 56.55 \quad \log \quad 1.752433 \\ 2R & = & 7639.66 \quad \text{colog} \quad 6.116926 \\ & & \hline \end{array}$$

$$d_1/2 = 0^\circ 25' 27'' \quad \log \sin \quad 7.869359$$

$$\Delta/4 - d_1/2$$

$$\text{Remainder from } \frac{\Delta/4 - d_1/2}{D/2} = 04' 18'' = d_k/2.$$

# UNIVERSITY OF MICHIGAN

1909—XI—27.

Practice Survey:—Laying out a Circular Curve with  
Transit.

Location:—Hamilton Park, Ann Arbor, Mich.

9°59'30"	189°59'30"	113	+	75.65	P'T'.	Found
9°25'27"	189°25'27"	113				
8°40'27"	188°40'27"	113				
7°55'27"	187°55'27"	111				
7°10'27"	187°10'27"	110				
6°25'27"	186°25'27"	109				
5°40'27"	185°40'27"	108				
4°59'45"	184°59'45"	107	+	09.56	K'.	Found K'
4°55'27"	184°55'27"	107				
4°10'27"	184°10'27"	106				
3°25'27"	183°25'27"	105				
2°40'27"	182°40'27"	104				
1°55'27"	181°55'27"	103				
1°10'27"	181°10'27"	102				
0°25'27"	180°25'27"	101				
0°00'00"	180°00'00"	100	+	43.45	P. C.	1°30' C.R.



DEPARTMENT OF ENGINEERING.

Instruments:

Party:—II.

Transit No. 8333.  
100' Tape No. XX.  
50' Tape No. 21.

R. R. Roem.  
H. C. Walker.  
C. W. Wright.  
H. L. Wright.

$$\text{Remainder from } \frac{\Delta/2 - d_1/2}{D/2} = 34'04'' = d_2/2.$$

$$c_k = 2R \sin d_k/2 \qquad c_2 = 2R \sin d_2/2.$$

$$2R = 7639.66 \log 3.883074.$$

$$d_k/2 = 04'18'' \log \sin 7.097195.$$

$$c_k = 9.56 \log 0.980269.$$

behind and .17 inside of P. T

$$2R = 7639.66 \log 3.883074.$$

$$d_2/2 = 34'04'' \log \sin 7.995836.$$

$$c_2 = 75.67 \log 1.878910.$$

nd and .23 inside of K.

$$\Delta = 19^\circ 59'00''.$$

$$T = 672.96.$$

$$E = 58.83.$$

$$L = 1332.22.$$

$$= 19^\circ 59'00''.$$

## X. TRAVERSING.

### FIELDWORK.

#### 77. Outfit.

Transit.

Measuring set.

Two line staves.

Axe, stakes, and nails.

Examine the articles as issued, or be liable for defects found upon their return.

#### 78. Directions.

A field with seven sides, and one reentrant angle. No side less than 500 feet. To enclose from 30 to 40 acres.

#### 79. Stake out the field.

Designate the stakes by A, B, C, D, E, F, and G.

Record a description of each stake, and its general location, under its letter, in the notebook. Take four, or more, witnesses to each stake. Record these witnesses with description of stake.

#### 80. Forms of record.

Field of seven sides situated between Packard street and the Ann Arbor railroad south of Hill street, and north of the E. & W.  $\frac{1}{4}$  line of Section 32, T. 2 S. R. 6 E. Mer. of Mich. A, B, C, D, E, F, G, designate the vertices of the angles in the boundaries of this field.

⊙ A. Is a nail in a stake driven flush with the ground, standing on the third prominent ridge N. of the Detroit Observatory, Ann Arbor, Mich., from which a

*Witnesses.* Hickory, 12" in diameter, bears N. about  $55^{\circ}$  E., 72'.3 to its center, and a

B. Walnut 27" bears S. about  $35^{\circ}$  E. 261'.4 to cen.

Spike in root of Sycamore 32'', S. about 45° W. 47'.13.  
 Spike E. face of brick wall near S.E. corner of barn, N.W'ly  
 34'.27.

*Field notes of traverse to read from bottom of page  
 upward.*

### 81. Measure the sides.

Measure down hill.

As each measurement is made enter it in the sixth column of the record on the line with the note in the third column, showing in which direction the measurement proceeded. See form of record following.

### 82. Instrument work.

Set up the transit at any station, as A.

Backsight to G by means of either clamp and show motion screw, the other clamp being clamped.

Read both plate verniers. Record these readings in the two left hand columns of the field notes at the bottom of the page, with a note in the third column that the pointing is from A to G,—all as shown in the form of notes.

Take another look at the verniers and backsight, to make sure the pointing is exact and the vernier readings correctly recorded.

Release the plate clamp.

Set the line of sight on the mark at B by means of the plate clamp and slow motion screw.

Read both plate verniers. Record these readings in the fourth and fifth columns of the notes on the next line above the last entry, with a note in the third column that the pointing is from A to B.

Release the plate clamp. Set the line of sight again on A G by means of the plate clamp and slow motion screw.

Read both plate verniers. See if these readings agree sufficiently well with those when the first pointing A to G was made. If not, repeat the work till they will. Record these

- readings in the two left hand columns of the notes on the line next above the last entry, with a note, in the third column that the pointing is from A to G.
- Again direct the telescope to B, and set up a picket behind the eyepiece, facing B,—if pickets are used.
- Move the transit and set it up at B.
- Set the plate verniers at the same readings they had when the pointing was from A to B,—each vernier at its original reading,—do not exchange them.
- Set the line of sight on A, by means of the spindle clamp and slow motion screw.
- Read both plate verniers. Record these readings in the first and second columns of the notes, with a note in the third column showing the pointing to be from B to A.
- Leave one space blank between these and the last previous entries.
- Compare these entries in the first and second columns with the last previous ones in the fourth and fifth columns. If they are not the same, or as nearly so as can be, repeat the setting of the plate verniers and the pointing from B to A, till these records agree.
- Look once more at the verniers, and be sure they read correctly. Also notice the pointing and make sure it is exact.
- Release the plate clamp.
- Set the line of sight on C, by means of the plate clamp and slow motion screw.
- Read both plate verniers. Record these readings in the fourth and fifth columns of the notes on the next line above the last entries, with a note in the third columns showing the pointing to be from B to C.
- Release the plate clamp. Set the line of sight again on A by means of the plate clamp and slow motion screw.
- Read both plate verniers. See if these readings agree sufficiently well with those when the first pointing B to A was made. If not, repeat the work till they will. Record these readings in the two left hand columns of the notes on the line next above the last entry, with a note in the third column that the pointing is from B to A.





University of Michigan.

1903-10-29 Traverse Survey of Seven Sides of Field.  
 See pp. 65 to 70 for records of corners.  
 Backsights. Point-Foursights. Distances  
 Ver. A Ver. B ings. Ver. A Ver. B. in fact.

259°44'00". 79°44'30" E to D ✓  
 E to F 47°36'30" 227°36'00" 600.00

259°44'00". 79°44'30" E to D

39°57'30" 219°57'30" D to C ✓  
 D to E 259°44'00" 79°44'00" 499.91

39°57'00" 219°57'30" D to C

348°59'00" 168°59'00" C to B ✓  
 C to D 39°57'00" 219°57'30" 499.87

348°59'00" 168°59'00" C to B

244°17'00" 64°16'30" B to A ✓  
 B to C 348°59'30" 168°59'00" 500.00

244°17'30" 64°17'00" B to A 499.92

54°29'30" 234°29'00" A to G. ✓  
 A to B. 244°17'30" 64°17'00"

54°29'30" 234°29'00" A to G 1149.65

Department of Engineering. 71.

Party. Andrews, R. E.  
 Lathy, C. B.  
 Murdock, C. E.  
 Shober, M. R.

Transit B. & B.  
 1382.

C. E. Murdock.







University of Michigan

Department of Engineering.

1903-10-29 Traverse Survey of Seven Sided Field.

Party, - p. 71

Transit  
B.F.B. 1382.

Backsights	Point-	Foresights.	Distances
Ver A	Ver B	ings.	Ver A Ver B in feet.
184° 01' 00"	4° 01' 00"	G to F	✓
		G to A	234° 29' 00" 54° 29' 00" Closing error + 0° 00' 15"
184° 01' 00"	4° 01' 00"	G to F	
47° 36' 00"	227° 36' 00"	F to E	✓
		F to G	184° 01' 00" 4° 01' 00" 499.90
47° 36' 00"	227° 36' 00"	F to E	

C. E. Murdoch.





Again direct the telescope to C, and set up a picket behind the eyepiece, facing C,—if pickets are used.

Move the transit and set it up at C.

Repeat the same operations there, using first the plate readings obtained when sighting from B to C. Proceed in this way around the field until the transit is set up at G. When the plate readings for the pointing G to A are recorded, they should be the same as the plate readings when the pointing A to G was taken, with the readings exchanged between the verniers. If this is not the case review the work and correct the errors.

In a field with an even number of sides the readings will not be exchanged between the verniers.

## X. PEG LEVELS. LONG CIRCUIT.

### FIELDWORK.

#### 83. Outfit.

Level.

Leveling rod.

Axe. Pegs. Piece of chalk.

Examine the articles as issued, or be liable for defects found upon their return.

#### 84. Directions.

Run peg levels from the U. S. Geol. Sur. B. M.—El. 874.976. —in the south door of the Mechanical Laboratory and find the elevation of some other B. M. a mile, or so, away, and involving from 18 to 30 settings of the level, due to the distance, or difference in elevation. Make the record show the closing error, and the discrepancies peg by peg, if practicable. Follow the instructions for peg levels given under V.

## XI. COMPUTING AND PLATTING TRAVERSE.

### OFFICE WORK.

#### 85. Outfit.

Field notes of traverse survey.

#### 86. Traverse Angles.

Beginning in the central part of the notes, check off either vernier reading for the traverse angle of the side along which the forward pointing was made, that is, in those columns marked "Foresights." Proceeding each way from this traverse angle check off vernier readings, alternately in "Ver. A" column and "Ver. B" column, for the forward pointings along the several lines, till a traverse angle is marked for each side of the survey.

#### 87. Prepare book.

Make eight columns, about an inch and a quarter wide, across the open field note, book, using the following headings:

Trav. Ang. Dist. +  $s$  —  $s$  +  $c$  —  $c$   $x$   $y$ .

#### 88. Enter notes in above form.

Enter in the first column the traverse angles checked off in the field notes, and in the second column on the same line with each traverse angle, the length of the side to which it belongs. Leave a blank above each entry.

#### 89. Compute the traverses, $s$ and $c$ .

$A$  = traverse angle of any side.

$d$  = length of the side  $A$  belongs to,—always plus.

Signs of  $\sin. A$  and  $\cos. A$  are according to the quadrant in which  $A$  ends.

Compute  $\pm s = d \sin. A$ .

and  $\pm c = d \cos. A$ .







University of Michigan.

Department of Engineering.

1903-10-30 Traverse Survey of Seven Sided Field.  
Computations.

Party, - p. 71.

Trav. Dist.

	Ang.	+ S	- S	+ C	- C	X	Y	
A to B	244° 17' 15"	499.92	4150.46	450.46	216.88	- 450.46	- 216.88	B
			<del>450.42</del>		<del>216.89</del>			
		95.46			490.77			
B to C	168° 59' 15"	500.00	95.51		490.77	- 355.00	- 707.65	C
			<del>95.51</del>		<del>490.77</del>			
		320.96		383.13				
C to D	39° 57' 15"	499.87	321.00	383.13		- 34.04	- 324.52	D
			<del>321.00</del>	<del>383.13</del>				
		491.86		89.12				
D to E	79° 44' 00"	499.91	491.91	89.10		+ 457.82	- 235.40	E
			<del>491.91</del>	<del>89.10</del>				
		443.05		404.56				
E to F	47° 36' 00"	600.00	443.10	404.54		+ 900.87	+ 169.16	F
			<del>443.10</del>	<del>404.54</del>				
		34.98		498.68				
F to G	4° 01' 00"	499.90	35.02	498.67		+ 935.85	+ 667.84	G
			<del>35.02</del>	<del>498.67</del>				
			935.85		667.84			
G to A	234° 29' 00"	1149.65	935.75	667.87		000.00	000.00	A
			<del>935.75</del>	<del>667.87</del>				
		1386.31	1386.31	1375.49	1375.49			
		<del>1386.31</del>	<del>1386.31</del>	<del>1375.49</del>	<del>1375.49</del>			
	$\Sigma \alpha = 4249.25$	<del>1386.54</del>	<del>1386.17</del>	<del>1375.43</del>	<del>1375.55</del>			
		+ 0.37 = $\Sigma S$		$\Sigma C =$	- 0.12			

R. E. Andrews.





University of Michigan.

Department of Engineering. <sup>74.</sup>

1903-10-30 Traverse Survey of Seven Sided Field.  
Computations.

Party, - p. 71.

+ Double Areas. - Double Areas.

$-x_n(C_n + C_{n+1})$

318768.0190

38212.2000

16075.3900

226016.5776

813701.8188

158308.3860

174383.7760

1396698.6154

174383.7760

2) 1222314.8394

611157.4197 Square feet

+ Double Areas.

- Double Areas.

$+y_n(S_n + S_{n+1})$

76992.4000

294679.6130

263776.3464

220077.8140

80863.5548

601637.0208

157855.9548

1380170.7942

157855.9548

1222314.8394

C. B. Lathy.





Sample computation.

s		c
2.528274	337.50	2.528274
9.820774	41° 26' 30"	9.874847
2.349048		2.403121
+223.38		+253.00

Take out the results to the second decimal place, only.

Enter these values of  $s$  and  $c$  in their proper columns against the values of  $d$  from which they came.

Find  $\Sigma s$  and  $\Sigma c$ . Both should equal zero.

### 90. Errors.

In case the difference from zero of  $\Sigma s$  and  $\Sigma c$  is large, review all the figures from the checking off of the vernier readings, and correct all errors found.

If the difference from zero is still large, review, and verify, the work in the field.

When the errors are found and corrected  $\Sigma s$  and  $\Sigma c$  will nearly equal zero.

### 91. Balancing traverses.

Find and correct all errors that can be found, and bring  $\Sigma s$  and  $\Sigma c$  as nearly to zero as practicable before applying any corrections.

Compute the corrections for any traverse by the following equations:

For the sine traverses,

$$\pm Cs = \frac{\Sigma s}{\Sigma d} d$$

For the cosine traverses,

$$\pm Cc = \frac{\Sigma c}{\Sigma d} d$$

Use the different values of  $d$  in succession to obtain the corrections for the traverse of the various sides. Subtract these corrections from the traverses to which they apply, observing all signs.

Enter the corrected values of the traverses in the blank spaces above the traverses as first computed. Draw neat pencil marks through the former values.

Find  $\Sigma s$  and  $\Sigma c$  anew, using the corrected traverses. They may still not quite equal zero. In this case apply any small remaining errors to the traverses of one or more of those sides the field data for which is most open to suspicion of being erroneous. In case there are no such sides apply the final corrections to the traverses of the longest side, or sides.

By repeating the first corrections a second or even a third time, in the case of some very poor work, and by distributing the small remaining errors as above directed, finally bring  $\Sigma s$  and  $\Sigma c$ , both to actual zero.

## 92. Computing coordinates, $x$ and $y$ .

$$x = \Sigma s \qquad y = \Sigma c.$$

Observe all signs carefully.

Find the sum of the sine traverses to the end of each side of the field in succession, for the values of  $x$ . Similarly, sum the cosine traverses for the values of  $y$ . The last  $x$  and the last  $y$  must be zero.

## 93. Prepare book.

Make four columns about two inches wide, two on each page of the open field note book, using the following headings:

$$+ D. A. \quad - D. A. \quad + D. A. \quad - D. A.$$

$D. A.$  means double area.

Compute:

$$\begin{aligned} D. A. &= \Sigma -x_n (c_n + c_{n+1}) \\ &= \Sigma +y_n (s_n + s_{n+1}) \\ &= \Sigma -c_n (x_n -_1 + x_n) \\ &= \Sigma +s_n (y_n -_1 + y_n) \\ &= \Sigma +x_n (y_n +_1 - y_n -_1) \\ &= \Sigma +y_n (x_n +_1 - x_n -_1) \end{aligned}$$







COMPUTATIONS RELATING TO A CLOSED SURVEY.

SYMBOLICAL TABLE

TRAV ANGLE	DIST.	TRAVERSES		COORDINATES		DOUBLE AREA	DOUBLE AREA	DOUBLE AREA	DOUBLE AREA	DOUBLE AREA	DOUBLE AREA
		$s = d \sin A$	$c = d \cos A$	$X = \Sigma s$	$Y = \Sigma c$						
$A$	$d$	$s = d \sin A$	$c = d \cos A$	$X = \Sigma s$	$Y = \Sigma c$	$-X_n \left( \frac{c+c}{n \ n+1} \right)$	$Y_n \left( \frac{s+s}{n \ n+1} \right)$	$-c \left( \frac{x+x}{n \ n+1} \right)$	$s \left( \frac{y+y}{n \ n+1} \right)$	$-X_n \left( \frac{y-y}{n \ n+1} \right)$	$Y_n \left( \frac{x-x}{n \ n+1} \right)$
$A_1$	$d_1$	$s_1 = d_1 \sin A_1$	$c_1 = d_1 \cos A_1$	$X_1 = s_1$	$Y_1 = c_1$	$-X_1 \left( \frac{c_1+c_2}{1 \ 2} \right)$	$Y_1 \left( \frac{s_1+s_2}{1 \ 2} \right)$	$-c_1 \left( \frac{x_1+x_2}{1 \ m+1} \right)$	$s_1 \left( \frac{y_1+y_2}{1 \ m+1} \right)$	$-X_1 \left( \frac{y_2-y_1}{1 \ m+1} \right)$	$Y_1 \left( \frac{x_2-x_1}{1 \ m+1} \right)$
$A_2$	$d_2$	$s_2 = d_2 \sin A_2$	$c_2 = d_2 \cos A_2$	$X_2 = X_1 + s_2$	$Y_2 = Y_1 + c_2$	$-X_2 \left( \frac{c_2+c_3}{2 \ 3} \right)$	$Y_2 \left( \frac{s_2+s_3}{2 \ 3} \right)$	$-c_2 \left( \frac{x_1+x_2}{2 \ m+1} \right)$	$s_2 \left( \frac{y_1+y_2}{2 \ m+1} \right)$	$-X_2 \left( \frac{y_3-y_1}{2 \ m+1} \right)$	$Y_2 \left( \frac{x_3-x_1}{2 \ m+1} \right)$
$A_3$	$d_3$	$s_3 = d_3 \sin A_3$	$c_3 = d_3 \cos A_3$	$X_3 = X_2 + s_3$	$Y_3 = Y_2 + c_3$	$-X_3 \left( \frac{c_3+c_4}{3 \ 4} \right)$	$Y_3 \left( \frac{s_3+s_4}{3 \ 4} \right)$	$-c_3 \left( \frac{x_2+x_3}{3 \ m+1} \right)$	$s_3 \left( \frac{y_2+y_3}{3 \ m+1} \right)$	$-X_3 \left( \frac{y_4-y_2}{3 \ m+1} \right)$	$Y_3 \left( \frac{x_4-x_2}{3 \ m+1} \right)$
$A_4$	$d_4$	$s_4 = d_4 \sin A_4$	$c_4 = d_4 \cos A_4$	$X_4 = X_3 + s_4$	$Y_4 = Y_3 + c_4$	$-X_4 \left( \frac{c_4+c_5}{4 \ 5} \right)$	$Y_4 \left( \frac{s_4+s_5}{4 \ 5} \right)$	$-c_4 \left( \frac{x_3+x_4}{4 \ m+1} \right)$	$s_4 \left( \frac{y_3+y_4}{4 \ m+1} \right)$	$-X_4 \left( \frac{y_5-y_3}{4 \ m+1} \right)$	$Y_4 \left( \frac{x_5-x_3}{4 \ m+1} \right)$
etc	etc	etc	etc	etc	etc	etc	etc	etc	etc	etc	etc
to	to	to	to	to	to	to	to	to	to	to	to
$A_m$	$d_m$	$s_m = d_m \sin A_m$	$c_m = d_m \cos A_m$	$X_m = X_{m-1} + s_m$	$Y_m = Y_{m-1} + c_m$	$-X_m \left( \frac{c_m+c_1}{m \ 1} \right)$	$Y_m \left( \frac{s_m+s_1}{m \ 1} \right)$	$-c_m \left( \frac{x_{m-1}+x_1}{m \ m+1} \right)$	$s_m \left( \frac{y_{m-1}+y_1}{m \ m+1} \right)$	$-X_m \left( \frac{y_1-y_{m-1}}{m \ m+1} \right)$	$Y_m \left( \frac{x_1-x_{m-1}}{m \ m+1} \right)$
		When corrected		If $X = a$	If $Y = b$	Sum of entries in any double area column					
		$\Sigma s = 0$	$\Sigma c = 0$	$X = a \cdot \Sigma s$	$Y = b \cdot \Sigma c$	equals double area of piece. Use two columns.					
		Observe all signs		Plat is made							
				by coordinates.							



Observe all signs carefully.

Use two of these forms.

Enter the results obtained by the two different forms, on the two different pages, the + results in the + *D. A.* columns and the — results in the — *D. A.* columns.

Do not use logarithms in these computations of *D. A.*, but natural numbers. Take both decimals in all the values of *s*, *c*, *x*, and *y*, thus giving four decimals in each product.

Sum the products on each page for the double area of the field. These sums must be identical out to the last right hand figure.

Divide the double area by 2 to get the area of the field. Reduce the area to acres.

#### 95. Directions. Platting.

Each person make a plat of the traversed field, on cross ruled paper. See Sec. 10.

Select the origin and axes of coördinates. Assume a scale. Count off the coördinates of A, B, C, &c., and mark them on the paper.

Measure A to B, B to C, &c., to scale on the paper. See if these measures agree with those made on the ground. If not, correct the platting.

Join A and B, B and C, &c., by plain black lines, not too broad.

Complete the plat according to the instructions in Sec. 10. Fasten the plat in the field note book to the stub of a cut out leaf.

The axis of Y is the reference line and the + direction is  $0^\circ$  for the traverse angles. If the plate readings that were not checked had been taken as the traverse angles the  $0^\circ$  would have been in the opposite direction.

## XI. PROFILE LEVELING.

FIELD WORK. PARTY OF FOUR PERSONS.

### 96. Outfit.

Transit.

Measuring set.

Two line staves.

Axe. 30 or 35 stakes. 3 or 4 plugs. Nails. Marking chalk.

Levels,—2.

Leveling measuring rods, 2.

Axe. Pegs,—about 50.

Examine the articles as issued, or be liable for defects found upon their return.

### 97. Directions.

On rough ground select a place where a straight line about 3000 ft. long can be laid out, and either end of it seen from the other.

Drive a plug with nail in same, to mark the end of the line where the measuring is to begin,—or zero end.

Witness this plug. Record full information about it.

Mark a stake with the line mark and the numeral 0.

Drive this stake about a foot to the right of the plug, as the line will run, with the marks facing away from the other end of the line.

Set up the transit over the nail in this plug.

Drive another plug with nail to mark the line near its other end.

Witness this plug. Record full information about it.

Hold up a line staff on the nail in this plug.

Set the line of sight of the transit on the line staff.

Take away the line staff.

Set a picket in line beyond the distant plug,—or any suitable mark to keep the line by,—or find some object in exact line to be used to sight to for line.

Hold up the line staff again, on the nail in the distant plug. See if the cross wire bisects it exactly. If not, review the work and correct the errors, till sure the distant mark is in exact line.

Call back the line staff.

Watch the transit while laying out the line; by frequent references to the distant mark for line; by looking at the plate levels to see that the bubbles read level, especially the one parallel to the transit axis; and occasionally examining the plumb bob to see if it keeps exactly over the nail in the plug.

Measure 100 ft. from the nail under the transit in the direction the line is to go.

Get line at the end of the 100 ft. with the line staff.

Mark a stake with the line mark and the numeral 1.

Drive this stake at the end of the 100 ft. on the line, and with the marks facing the plug where the transit stands.

Drive the stake so it stands plum and is firmly set.

Test it for line and distance. Correct it for either, or both, by pounding the ground close beside the stake, but leave it plumb and firm. Move it if necessary.

Measure again and mark 100 ft. on top of the stake.

Get line on the stake at the end of the 100 ft.

Drive a small nail in the top of the stake to mark station 1 at just 100 ft. from station 0,—the nail under the transit,—and in line.

Measure on 100 ft. beyond 1 and set and mark 2 with the same care and precautions used at 1.

Continue setting stakes in this manner until the whole line is marked or some place is reached where it becomes necessary to move up the transit in order to see to give line for the stakes.

Choose a place for a new transit plug from which the distant line mark can be seen and also the succeeding stakes to be set.

Look over the transit and see that it is over the nail, is level, and the line of sight is on the distant mark.

Give line for the new plug.

While the plug is being driven look the transit over again for position, level, and line, and be ready to give line at once.

Get line on the plug with the line staff.

Mark the place.

Take away the line staff.

See that the line of sight strikes the distant mark.

If not, review the work and correct the errors until it will.

Signal "All right."

Drive a nail, not quite down, at the mark on the plug.

Call up the transit.

While the transit is coming, measure the plus from the preceding stake and record this plus and any other information about the plug.

Mark a stake with the line mark and station number and plus for this plug, and drive it about a foot to the right of the plug.

Set up the transit over the nail in the new plug.

Set its line of sight on the distant mark.

Measure 100 ft. from the last regular station set, not the transit plug, if at a plus, and continue setting stakes, as before.

Continue marking the line somewhat beyond the last distinctive depression, or rise, on the line, even if it is a few hundred feet more than 3000 ft. long.

This is the manner of marking what is called a "Located line" in Leveling and Earthwork.

Divide into parties of two persons.

Find, or make, a B. M. at each end of the line.

Record full description of these benches.

Find, by peg levels, the elevation of one of them, say the one at the zero end of the line, or assume an elevation for it.

With one of the levels begin leveling from the B. M. at the zero end of the line, following the instructions given in Leveling and Earthwork in sections 1 to 13. Section 10 gives special instructions about Location Levels, such as these should be.



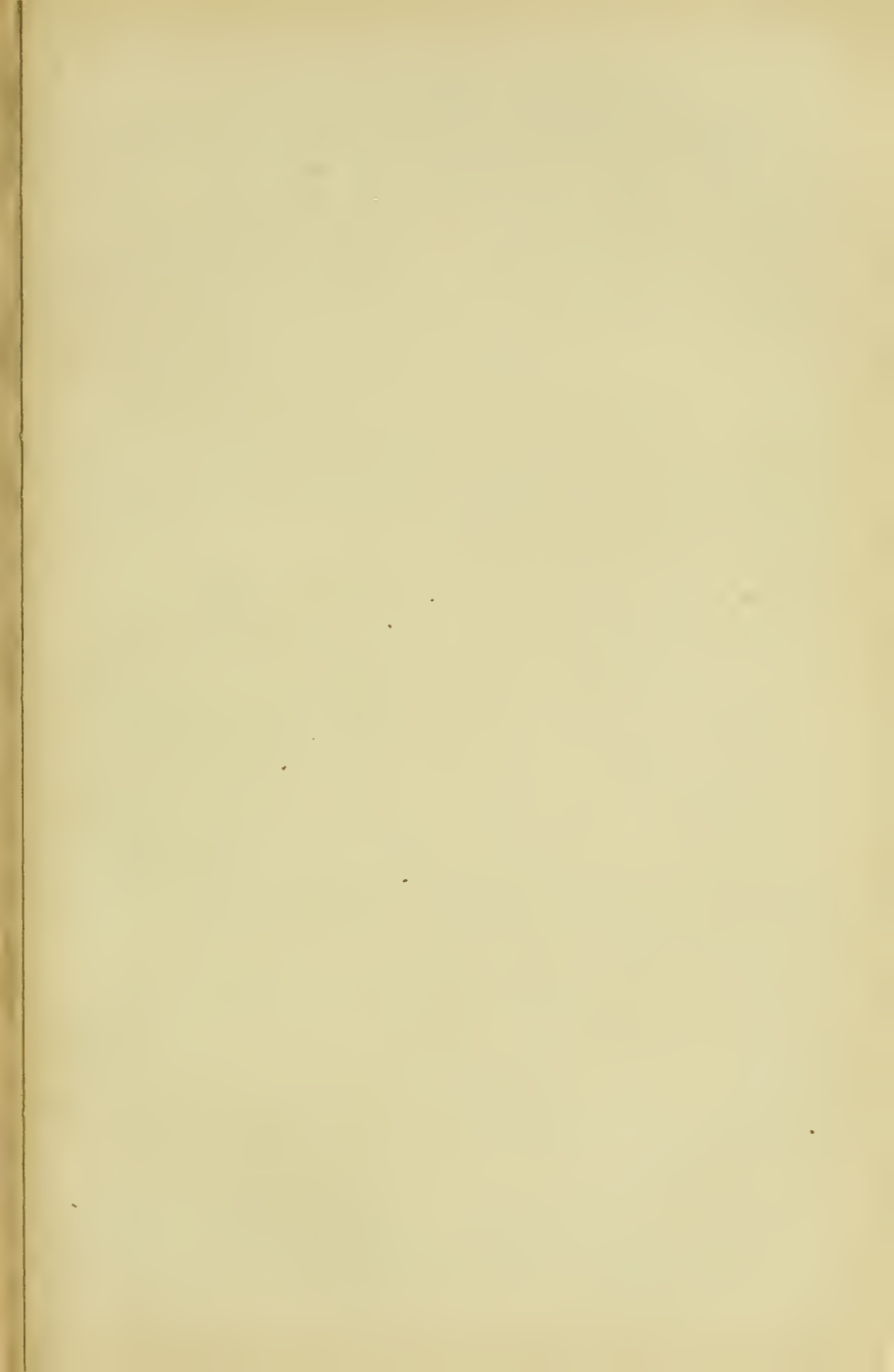



Continuous Level Notes  
 Jumper Hill and Sunny Grove R. R.

Rodman's Book.  
 Line L. Location. 1890-7-14.

Maple Bough Township.

+ S.	xc. I	- S.	El.	Ch.
			104.632	B.M. Root of a
4.785	109.417			
		5.931	103.486	3+45 I.P.
6.421	109.907			
		10.432	99.475 o.k.	B.M. Root of a
		10.365	99.542	I.P.
0.861	100.403			
		11.170	89.233	11+50 I.P.
0.417	89.650			
		10.978	78.672	I.P.
0.396	79.06			
		9.294	69.774	11+70 I.P.
		8.437	70.631 o.k.	B.M. Root of
		10.496	68.572	11+95 Edge of

F. Walker, leveller  
 S. Pohe, rodman.  
 16" Beech, 65 ft Left of 748+75, Line B  
 14" Hard Maple, 80 ft R. of 7+70 where line leaves woods  
 Proof 104.63 Proof. 99.475  
 4.785 10.432  
 6.421 5.931 0.861 10.365  
 10.432 0.417 11.170  
 99.475 0.396 10.978  
 115.838 115.838 8.437  
 70.631  
 27" Elm 75' L. of 11+75. 111.581 111.581  
 water in Crystal Lake Water level

Round soft marsh

4.633	4.557
3.741	3.817
4.692	4.713
13.066	13.087

Proof

+ S	- S
79.068	
4.633	4.557
3.741	3.817
4.692	4.713
	0.368
	78.679
92.134	92.134

79.047	0.021		
10.477	68.570	18+48.	Edge of
0.368	78.679	B.M. x	on a
	o.k.		

water in Crystal Lake Water level.  
 6' boulder, 2' out of ground, 80 R. of Sta. 19.













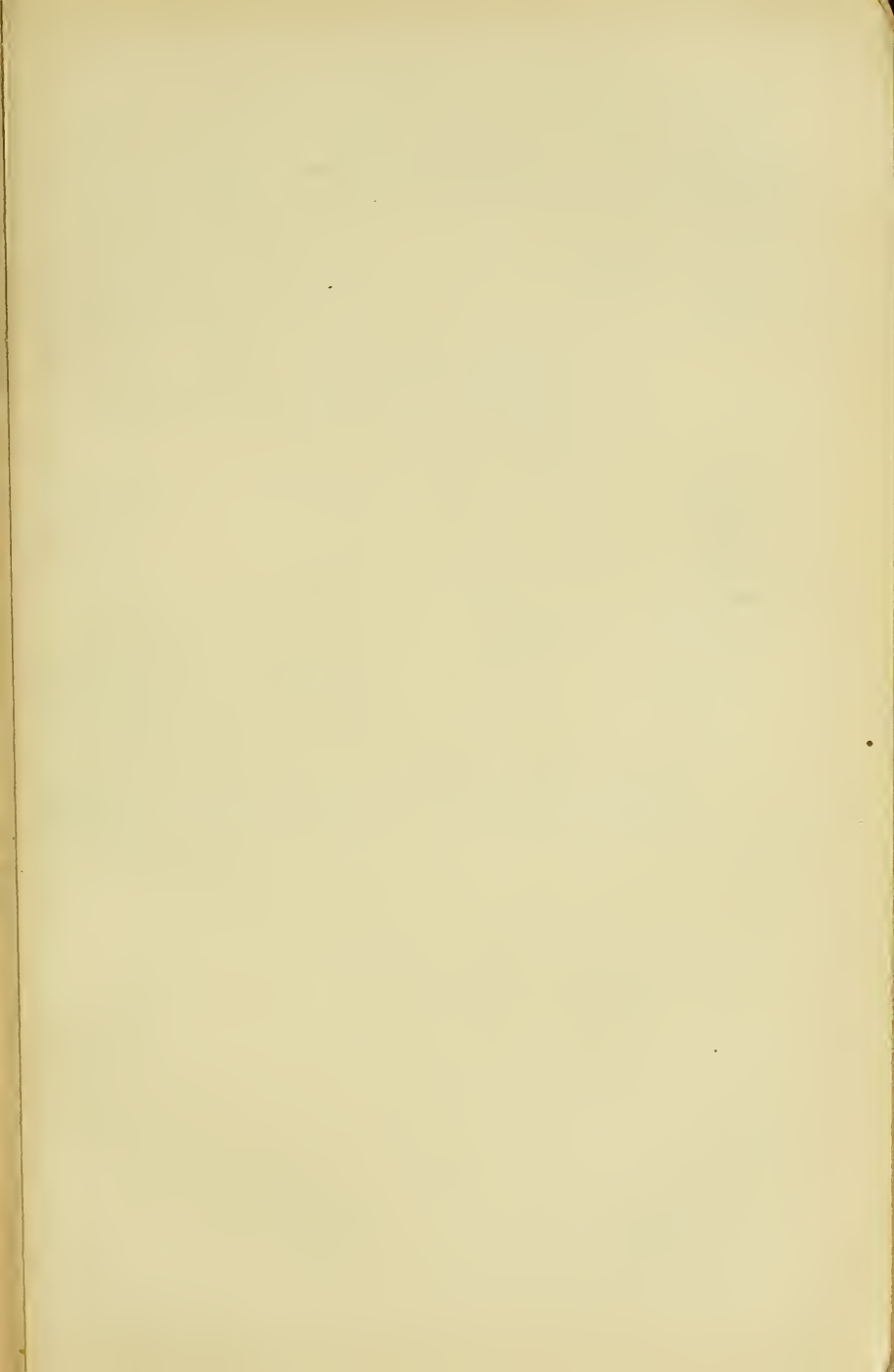



	J.	J-C	f	S.	g	R	R.	Line L	
+ S	H I	- S.	8l	6b		F. Walker,	Lev.	S. Poke. Rod	1890-7-14

109.197

0 973 108.2240.K B.M. Root of 38" White Pine, 75' R. Sta. 42.

Proof

End of these levels

		+ S	- S
	Proof	137.355	
	+ S	1.978	
			10.307
	119.218		
	0.371		0.527
	0.363	10.755	9.281
		0.973	<u>119.218</u>
		<u>108.224</u>	139.333
	<u>119.952</u>	<u>119.952</u>	139.333

This line was continued by S. Eye and S. Toe in 1898 See next page





	J.	H.	V.	S.	G.
+ S.	H. I.	- S.	El.	B.M.	p. 42.
0.741	108.965	11.424	97.541	43	I.P.
0.749	98.290	11.723	86.567	43+60	I.P.
0.521	87.088	11.682	75.406	43+85	I.P.
0.674	76.080	11.593	64.487 0.1k.	44+30	B.M. X
0.479	64.966	11.462	53.504		I.P.
-6.740					
+6.272					
-0.468	53.036	10.335	42.701 0.1k.	44+70	B.M. X
-6.740					
+0.776					
-5.964	36.737	11.630	25.107 0.1k.		B.M. X top of ledge, 65' L of Sta. 45.
0.652	25.759	5.121	20.638	45+35	I.P.
0.499	21.137	11.311	9.826	45+50	I.P.
0.501	10.327	5.390	4.937	0.1k.	B.M. Root of twisted white pine 100' L.
		11.483	-1.156 0.1k.	45+85	I.P.

R.	R.	Line	L.	Lev. - B level 149.
S. Eye.	Lev.	S. Tol. Rod.		1898-6-1.
			+ S. Proofs.	- S.
		Brow of steep descent.	108.224	
			0.741	
			0.749	11.424
			0.521	11.723
			0.674	11.682
				11.593
		top of step in granite ledge on line.	110.909	64.487 110.909
		Top of stake.	64.487	
			0.479	
		edge of shelf of rock, on line.		11.462 0.468 10.335
				42.701
		Prominent projection.	64.966	64.966
			+ S Proof - S	
			4.937	11.483
			5.390	42.701
			- 1.156	5.964
			10.327	11.630
			10.327	25.107
				42.701
		45+50. No other pine near.		42.701



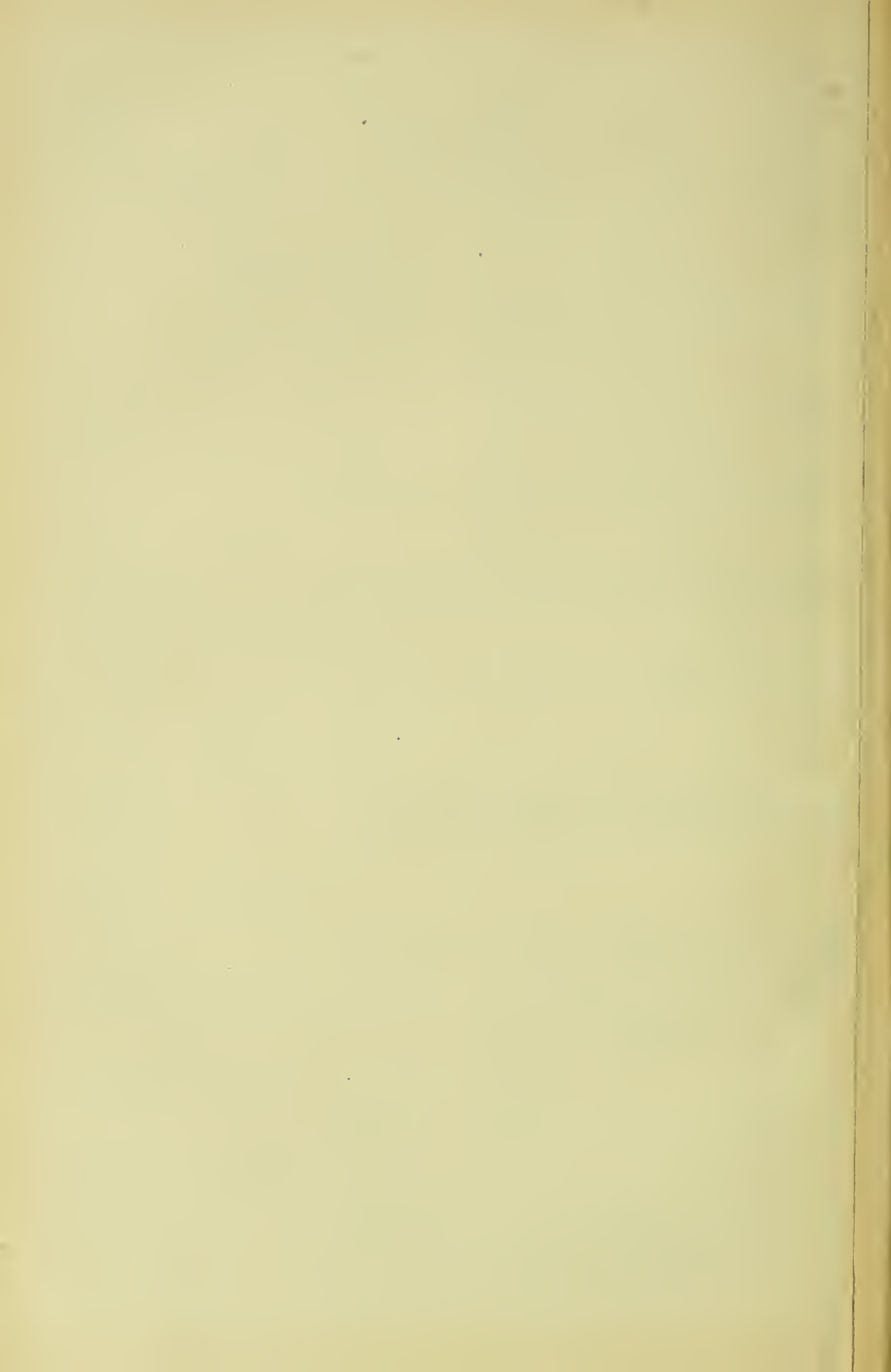



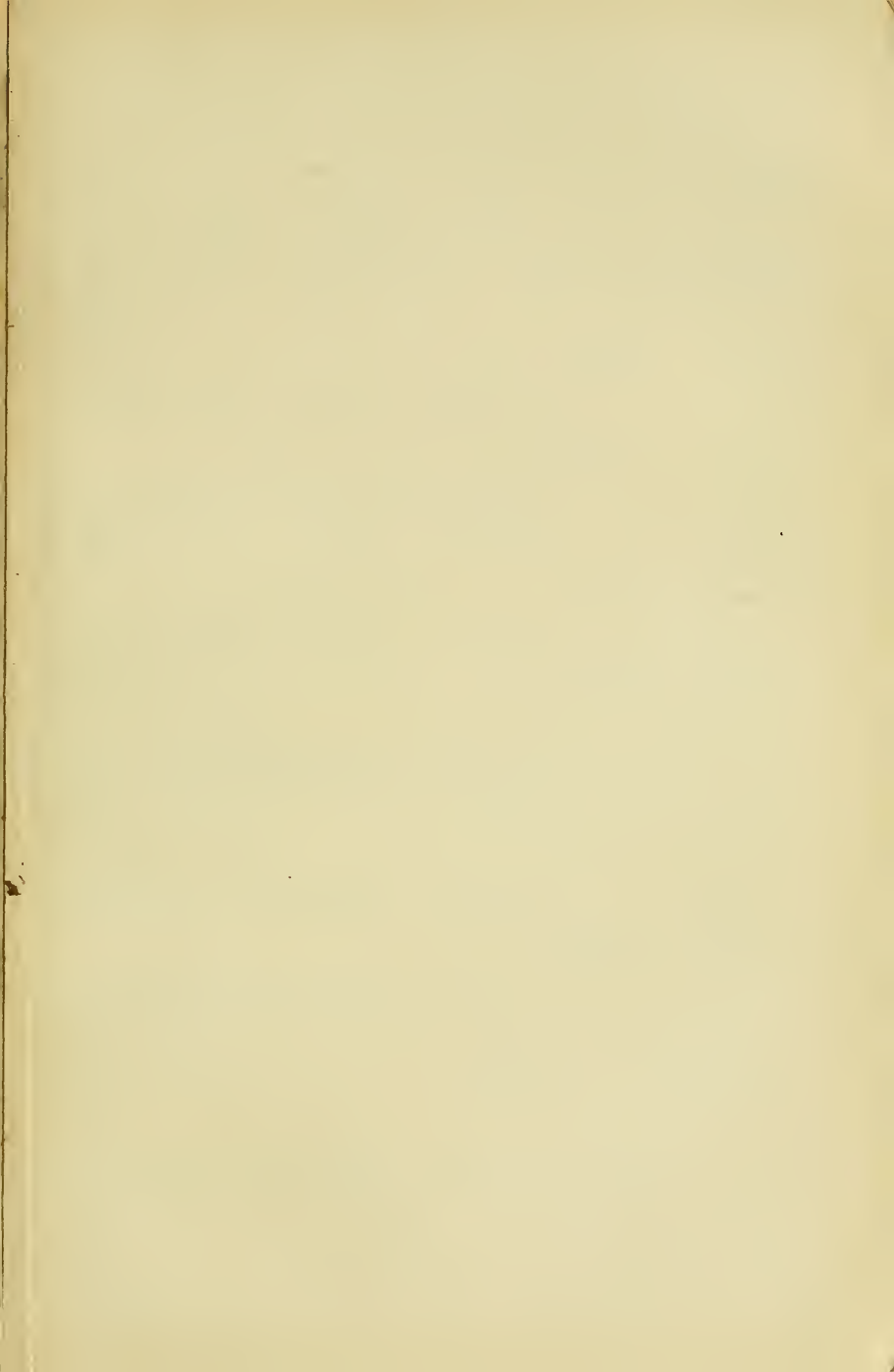



	J.	H.	I.	S.	E.	R.	R.	Line L.	
+ S	J.C. I.	- S.	Bl.	Al.		S. Eye. Lev.	S. Tol. Rod.	Lev. - Blunt 149.	
			-1.156		T.P. last page.			1898-6-1.	
0.636	- 0.520							+ S Proofs.	- S
		11.326	- 11.846	46+10	T.P.			0.636	1.156
0.577	- 11.269.							0.577	11.326
		3.492	- 14.761	O.K. B.M. X	on st	ep	on side of large detach-	<u>14.761</u>	<u>3.492</u>
		11.333	- 22.602	46+50	T.P.		ed fragment of rock, 15'	15.974	15.974
0.482	- 12.120						thick, near middle, about		
		11.510	- 33.630	46+75	T.P.		2' above ground on side	3.492	14.761
0.431	- 33.199						next to spring which is	0.482	11.333
							75' L. 46+25.	0.431	11.510
		2.277	- 35.476	O.K. B.M. X	on st	ep	of limestone ledge, about	<u>35.476</u>	<u>2.277</u>
							4' above ground, 75' R. of	39.881	39.881
							46+75.		
0.615									
0.778		0.782	- 33.981		T.P.		Top of stake. Sta. 50.	2.277	35.476
- 0.163	- 34.144								0.782
		0.222	- 34.366	O.K. B.M. X	on pro	jection	of limestone ledge,		0.163
							about 10' above ground, 150'	<u>34.366</u>	<u>0.222</u>
							R. of 55+50.	36.643	36.643

For connection with B.M. Line C. see next page.





J. H. & S. G.

R. R.  
S. Eye. Lev.

Line L.  
S. Tol. Rod.

Lev. - Blunt 149.  
1898-6-1.

Connection of B.M. 150' R. Sta. 55+50 Line L, with  
B.M. 70' L. Sta. 245+60 Line C.

+S	-S.	
0.222	34.366	B.M. Line L. p. 44.
3.926	8.471	
4.781	2.216	
1.466	5.311	
	9.987	

700.219 El. B.M. Line C. Root of 40" Sycamore 70' L. 245+60 C. on L. bank of  
Clam Creek.

750.000 Datum for Line L. above datum for Line C.

760.395 760.570

+0.175 Apparent error.

760.570 760.570

S. Tol, Rodman.







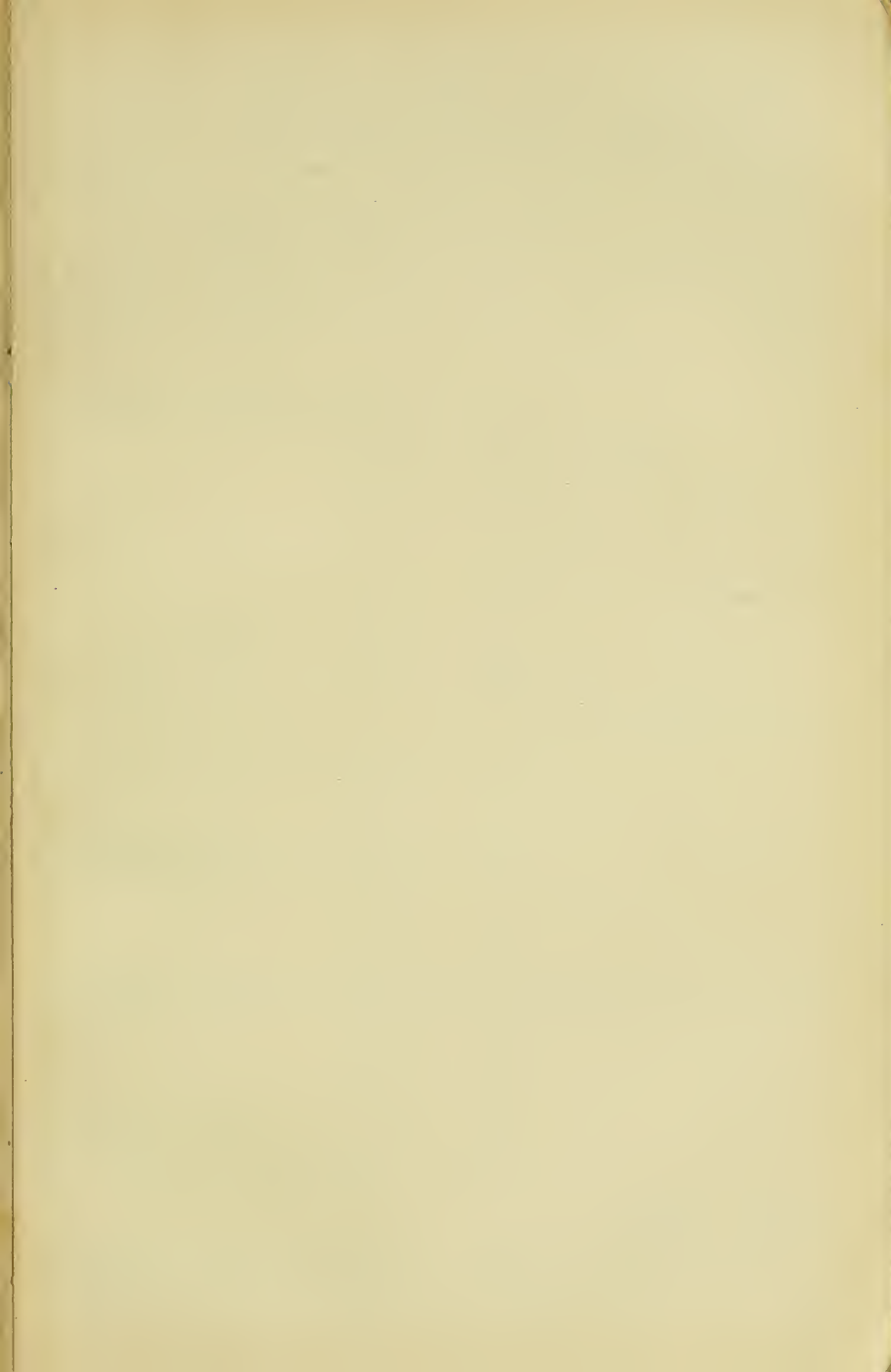



Continuous Level Notes.

Leveller's Book.

Juniper Hill and Sunny Grove R.R.

Line L.

Location.

1898-7-14.

Maple Bough Township.

F. Walker, leveller S. P. P. rodman.

+S. H. I. - S. Elevations Objects.

104.632 B.M. Root of 16" Beech Left of 748+75, Line B.

4.785 109.417

3.16 106.26 Sta 0 Line L = Sta 745 + 67.8 Line B.

4.78 104.64 1

6.32 103.10 2

5.46 103.96 + 40

9.27 101.15 3

6.24 103.18 + 25

5.931 103.486 + 45 T.P.

6.421 109.907

6.21 103.70 4

7.42 102.39 5

10.68 99.23 + 60 Bend of Phacid River (200' wide) 275' L.

9.31 100.60 6

9.24 101.68 7

10.432 99.475 B.M. Root of 14" Hard Maple 80' R. of 7+70 where line leaves woods

7.28 102.63 8

6.38 103.53 9

7.84 102.07 + 40 Center of highway.

10.365 99.542 O.K. 10 T.P.

0.861 100.403

8.26 92.14 + 75 Top of bank of small stream, running to R.

Proof

+ S - S

4.785

6.421 5.931

10.365

104.632 99.542

115.838 115.838



6  
6  
8.

h

~

	J.	H.	F	S.	G.	R.	R.	Line I.	
+ S	H. I.	- S.	El.	Ob.		F. Walker, Lev.		S. Poke, Rod.	1890-7-14.
	100.403								
		10.4	90.00	+76	Bottom of	bank.			Proof.
		11.3	89.1	+78	Center of	channel. Water 1.9 deep.		+ S.	- S
		10.6	89.8	+81	Bottom of	bank.		0.861	
		8.42	91.98	+83	Top of	bank.		0.417	11.170
		7.84	92.56	11				0.396	10.978
		8.32	92.08	+30				13.066	13.087
		11.170	89.233	+50	T. P.	Top of bank of Crystal Lake.			0.368
0.417	89.650							<u>99.542</u>	<u>78.679</u>
		10.978	78.672		T. P.			114.282	114.282
0.396	79.068								
		9.284	69.774	+70	T. P.	Bottom of bank.			
		8.437	70.631	B.M.	Root of	27" Elm 75' L of 11+75.			
		10.496	68.572	+95	Edge of	water. Water level.			
		11.1	68.0	12	Bottom of	lake. Sand. Firm.			
Round soft marsh.									
		4.633	4.557	60.7	14	7.9	"	"	"
		3.741	3.817	57.9	15	10.7	"	"	"
		<u>4.692</u>	<u>4.713</u>	60.5	16	8.1	"	"	"
		13.066	13.087	62.0	17	6.6	"	"	"
	79.047	0.021	66.0	18	2.6	"	"	"	"
		10.477	68.570	+48	Edge of	water. Water level.			
		9.20	69.8	+60	Bottom	of bank.			
		0.368	78.679	0.K.B.M.	X on a	6ft boulder, 2ft out of ground, 80' R. Sta. 19.			







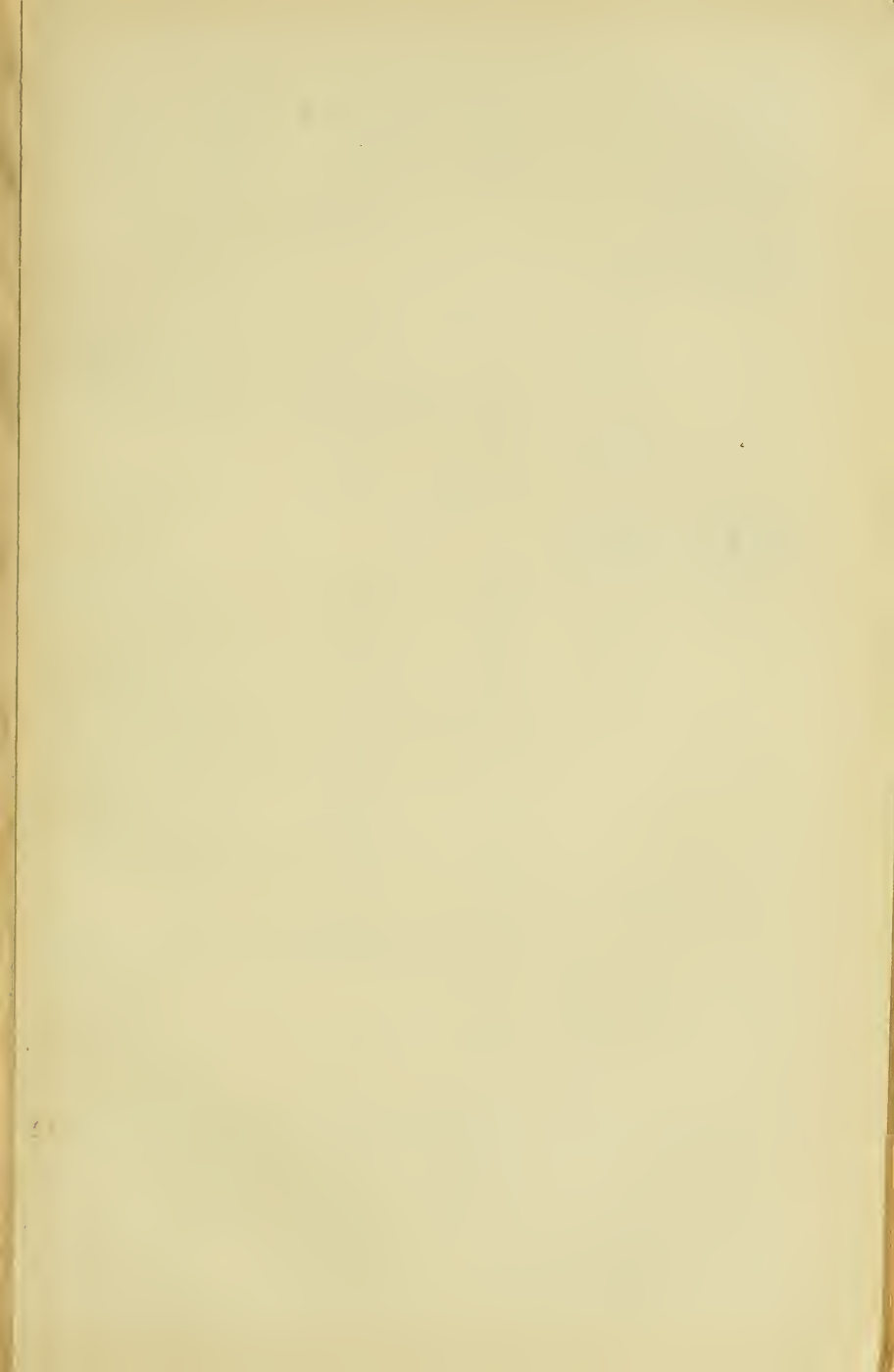



	J.	H.	H	S.	G.	R.	R.	Line I.	
+ S.	H.I.	-S.	El.	Alt.		F. Walker, Lev.		S. Poke, Rod.	1890-7-14.
			78.679	B.M.					
9.433	88.112								Proof.
		7.83	80.28		19				+ S      - S
		4.69	83.42	+ 35	Top of	bank, Crystal Lake.			9.433
		6.657	81.455	B.M.	Root of	10" Red Oak, 75 L. 19+50.			8.472      0.896
		3.73	84.38	+ 75					10.661      0.000
		0.896	87.216	20	T. P.				11.014      0.318
8.472	95.688								<u>78.679</u> <u>117.045</u>
		7.22	88.47	21	In edge	of corn field.			118.259      118.259
		5.72	89.97		22				
		5.21	90.48	+ 30					
		4.32	91.37	+ 80					
		6.61	89.08		23				
		7.51	88.18	+ 40					
		5.66	90.03	+ 55					
		3.97	91.72		24				
		0.000	95.688	+ 45	T. P. Peg	driven to elevation of cross wire.			
10.661	106.349								
		6.64	99.71	+ 65					
		4.73	101.62		25				
		3.627	102.722	B.M.	Top of W. T. stone fdn	S. E. cor. brick dwelling, 200' R Sta. 15.			
		3.07	103.28	+ 12					
		0.318	106.031	+ 35	T. P.				
11.014	117.045	0.14.							

1

11.



J. H.L. S. E.  
 H.I. -S. S.L. Ob.  
 117.045

R. R. Line L.  
 F. Walker, Lev. S. Poke, Rod.

1890-7-14.

7.62 109.42 +55  
 4.71 112.34 26  
 1.42 115.63 +55  
 0.000 117.045

Peg T.P.

Driven to elevation of cross wire.

Proof.

+ S. - S.  
 11.026 0.000  
 11.262 0.000  
 1.978

11.026 128.071

10.79 117.28 27.  
 10.07 118.00 + 15.  
 7.10 120.97 + 40.  
 3.60 124.47 + 60.  
 1.80 126.27 + 65.  
 1.01 127.06 28  
 0.000 128.071

Peg T.P.

Driven to elevation of cross wire.

117.045 137.355  
 139.333 139.333

11.262 139.333

10.47 128.86 + 25  
 8.66 130.67 29  
 3.71 135.62 + 90  
 3.61 135.72 30  
 3.02 136.31 + 33  
 1.83 137.50 + 50  
 1.80 137.53 + 70  
 2.11 137.22 31  
 2.15 137.18 + 55

Summit.

1.978 137.355  
 0.14.

B.M. Top of

cap stone (S.W. cor.), bridge seat, E. and highway bridge, over Roaring Creek, about 800ft W. of J. Smith's house.











1890-7-14

	J.	H.	f	S.	g.
+S.	H. I.	- S.	El.	at.	
	0.14				

3.25	136.08	32
5.14	134.14	+70
4.96	134.37	33
4.02	135.31	+62
5.23	134.10	34
7.51	131.82	+60
11.17	128.16	+80

Transit @ in fence at N. E. side of cornfield. Enter brush pasture

Boston Rod.

+ 6.100
<u>- 6.627</u>
- 0.527
128.499

10.307	129.026	
11.40	127.93	35
2.23	126.27	+70
4.64	123.86	+75
6.23	122.27	36
8.16	120.34	+50
9.63	118.87	37
9.281	119.218	

T. P. Top of stake at Sta. 35.

Proof

	+ S	- S
	139.333	10.307
		0.527
	0.371	9.281
	0.363	10.755
	<u>          </u>	<u>109.197</u>
	140.067	140.067

B.M. Root of 18" Rock Elm, 80' L. of 36+50.

0.371 119.589

11.62	117.97	+18
10.755	108.834	+70

T. P.

0.363 109.197 0.14.

1.08	108.12	38
4.12	105.08	39
4.17	105.03	+45





	J.	H.	f	S.	g.	R. R.	Line L.	
+ S	H. I.	- S.	El.	Ob.		F. Walker, Lev.	S. Poke, Rod.	1890-7-14.
	109.197	0.1k.						
		2.71	106.49	40				Proof.
		2.02	107.18	41				+ S            - S
		1.24	107.96	+ 60			109.197	0.973
		1.44	107.76	42				<u>108.224</u>
	0.973		108.224	0.K. B.M.	Root of W. Pine 38", 75ft R. of 42.		109.197	109.197

End of these levels.

Continuation of above levels.

S. Eye, Lev.    S. Toe, Rod.    Lev. - Blunt, 149.  
1898-6-1

	108.224	B.M. above.						
0.741	108.965							Proof.
		2.58	106.48	40				+ S            - S
		1.76	107.20	41			108.224	
		1.16	107.80	42			0.741	
		2.80	106.16	+ 35			0.749	11.424
		6.68	102.28	+ 55				11.723
		9.82	99.14	+ 80				<u>86.567</u>
	11.424		97.541	43	T. P.	Brow of steep descent.	109.714	109.714
0.749	98.290							
		6.13	92.16	+ 25				
		10.31	87.98	+ 50				
		11.723	86.567	+ 60	T. P.			
			0.K.					







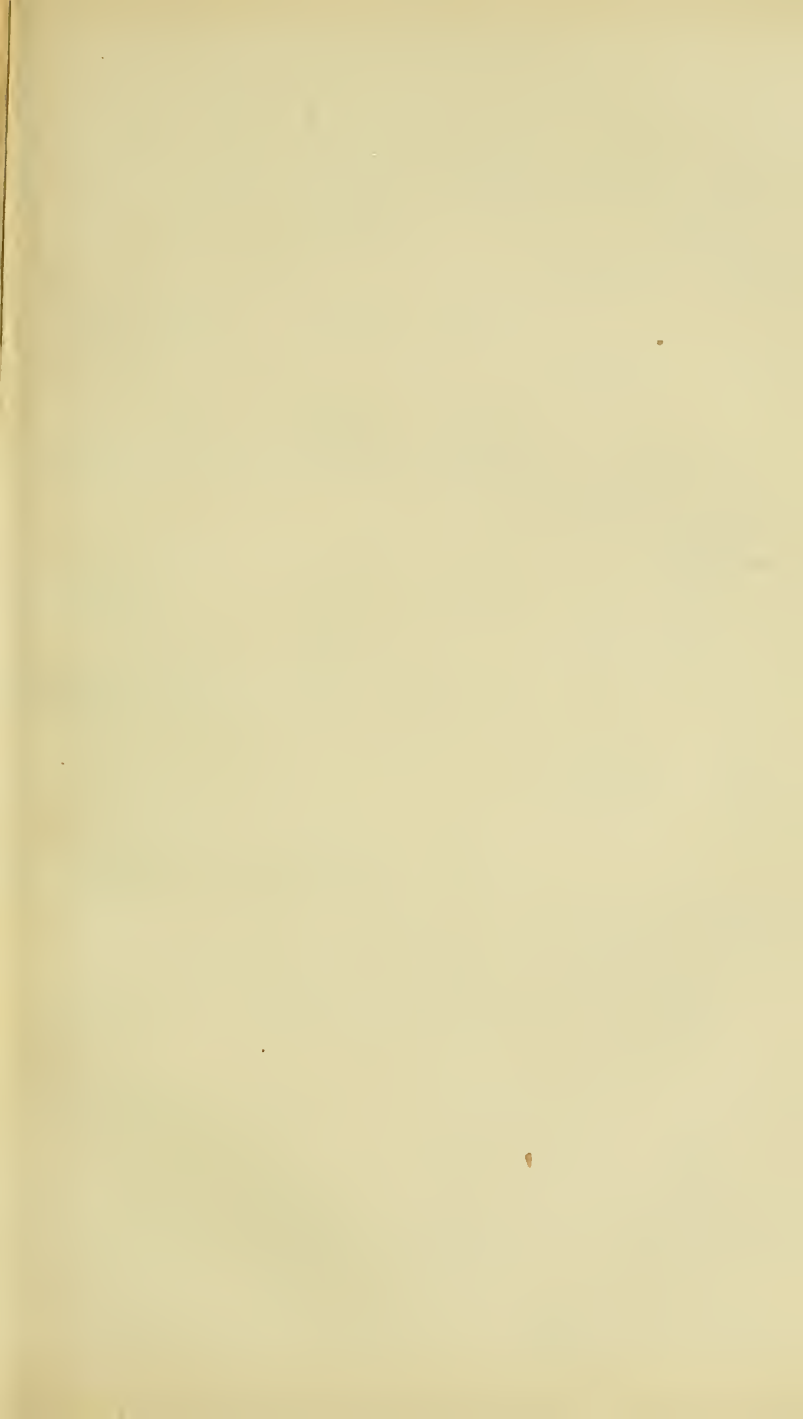



	J.	H.	f	S.	g.
+s	H.I.	-S.	El.	Al.	
			86.567	+60	T.P
0.521	87.088				
		11.682	75.406	+85	T.P.
0.674	76.080				
		8.21	67.87		44
		11.593	64.487	+30	B.M. X on top of step in face of ledge of syenite on line.
0.479	64.966				
- 6.740		8.21	56.76	+35	
+ 6.272		11.462	53.504		T.P. Top of stake.
- 0.468	53.036		52.00	+50	
- 6.740		10.335	42.701	+70	B.M. X Edge of shelf of rock, on line.
+ 0.776					
- 5.964	36.737				
		7.01	29.73		45
		11.630	25.107		B.M. Top of ledge, 65 ft L. of Sta. 45. Prominent projection.
0.652	25.759				
		2.34	23.42	+15	
		5.121	20.638	+35	T.P.
0.499	21.137				
		11.311	9.826	+50	T.P.
0.501	10.317				
		5.390	4.937		o.k. B.M.
		11.483	- 1.156	+85	T.P.
0.636	- 0.510				
	o.k.				

R. R. Line L.  
 S. Eye, Lev. S. Toe, Rod. Lev. - Blunt 149.

1898-6-1.

Proof.

+s	-s
4.937	
5.390	
0.636	11.483
<u>0.520</u>	
11.483	11.483

Proof

	-s
	11.682
	11.593
	11.462
	0.468
	10.335
	5.964
	11.630
	5.121
	11.311
	5.390
	<u>4.937</u>
	89.893
+s	
86.567	
0.521	
0.674	
0.479	
0.652	
0.499	
0.501	
	<u>89.893</u>

Root of twisted white pine 100 ft L. of 45+50. No other pine near.







J. H. I. H. I. - S. of El. S. @. S. S. R. R. Line L.  
 + S H. I. - S. El. @. S. S. S. Eye, Lev. S. Tol, Rod. Lev. - Blunt, 149.  
 - 0.520 1995-6-1

10.87 - 11.39 46  
 11.326 - 11.846 + 10 T.P.

0.577 - 11.269 0.14.  
 3.492 - 14.761 B.M. X  
 11.333 - 22.602 + 50 T.P.

0.482 - 22.120  
 11.510 - 33.630 + 75 T.P.

0.431 - 33.199 0.14.  
 2.277 - 35.476 B.M. X  
 3.33 - 36.53 47  
 4.12 - 37.32 + 20

5.10 - 38.30 + 80  
 3.02 - 36.22 48

Troy Rod  
 Upper target, 2.11 - 35.31 + 45

0.615 1.06 - 34.26 49

0.778 0.782 - 33.981

-0.163 - 34.144 0.14. 1.40 - 35.38 50

3.11 - 37.25 + 60

6.26 - 40.40 51

9.87 - 44.01 52

10.16 - 44.30 53

10.04 - 44.18 + 40

7.74 - 41.88 54

large  
 X on step on side of detached fragment of rock  
 15 ft thick, near central part, about 2 ft above  
 ground, on side next to spring which is 75 ft  
 L. of 46 + 25.

X on step of limestone ledge, in place, about 4 ft  
 above ground, 75 IR. of 46 + 75.

Proof.

Proof.

+	S	-	S	+	S	-	S
			0.520				0.520

	0.577	11.326		0.577	11.326
--	-------	--------	--	-------	--------

	14.761	3.492		0.482	11.333
--	--------	-------	--	-------	--------

T.P. Top of stake at Sta. 50.      0.431      11.510

	15.338	15.338			0.782
--	--------	--------	--	--	-------

Proof.

+	S	-	S		
				34.144	-----

	0.782	33.981		35.634	35.634
--	-------	--------	--	--------	--------

	<u>35.476</u>	<u>2.277</u>
--	---------------	--------------

	36.258	36.258
--	--------	--------

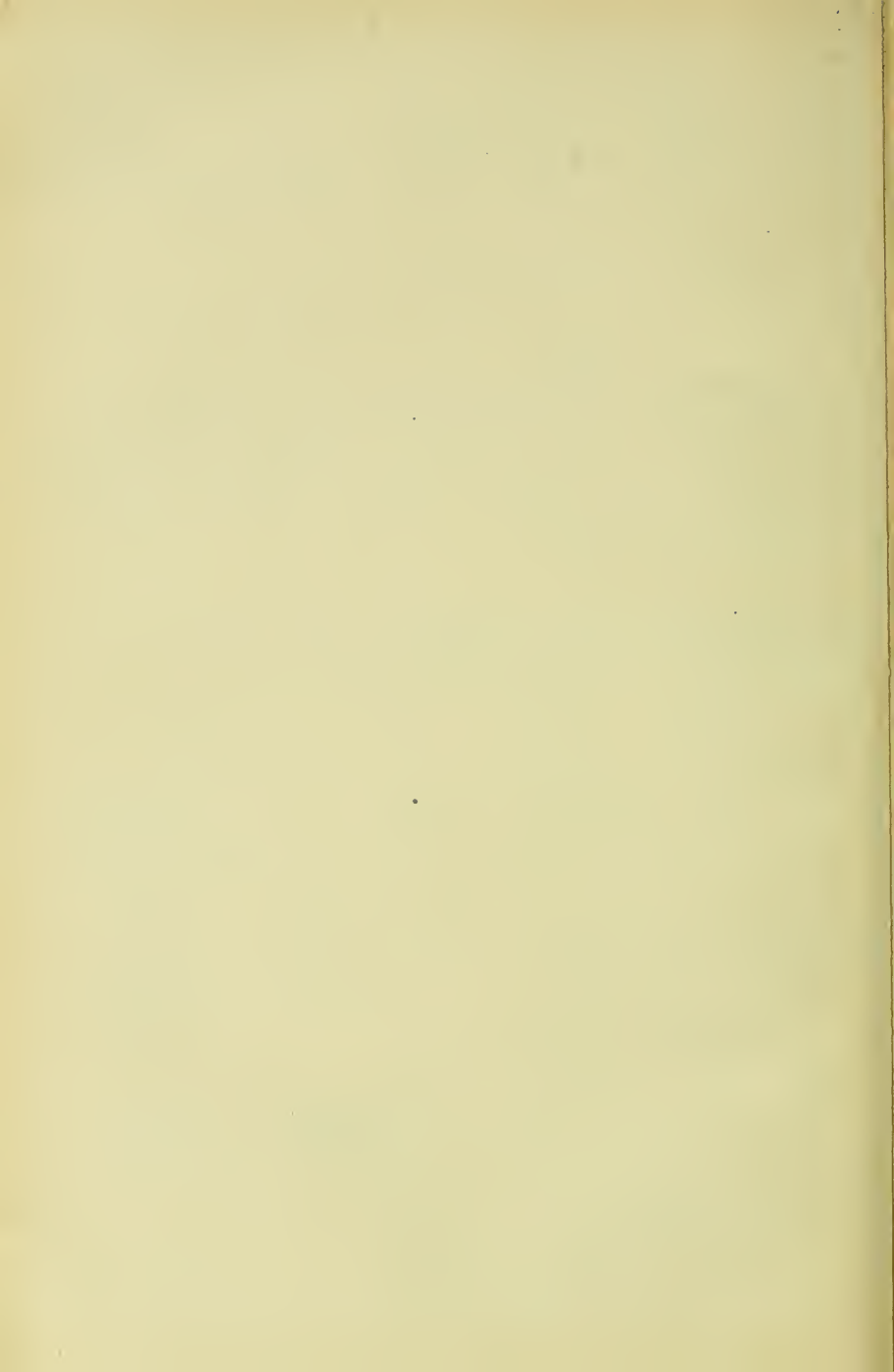







	J.	H.	V	S.	g.	R.	R.	Line L.
S.	H. I.	-S.	El.	Ob.		S. Eye, Lev	S. Toe, Root	Lev. - Blunt. 149
	-34.144							1898-6-1
		6.06	-40.20	+ 65				
		5.91	-40.05	55				
<hr/>								
Line C.	New El. from Line C Datum.	0.222	-34.366	B.M.	X	on projection of limestone ledge, in place, about 10ft above ground, and 150ft R. of 55+50.		
El.			0.14.					
		4.37	-38.51	55+37.6 =		271+59.3	of Line C	
712.90	712.70	3.16	-37.30	269C.				Proof.
712.82	710.64	5.22	-39.36	270C.				+ S - S
709.87	709.75	6.11	-40.25	271C.				34.144
707.33	707.17	8.69	-42.83	272C.				<u>34.366</u> <u>0.222</u>
708.25	708.09	7.77	-41.91	273C.				34.366 34.366

From above B.M. to B.M. on Line C Root of 40" Squamox 70ft L of 245+60 C. on L. bank of Cham Creek.

0.222	34.366
3.926	8.471
4.781	2.216
1.466	5.311
	9.987

750.000 Datum for Line L. above datum for Line C.  
700.219 El. B.M. Line C above noted.  
 760.395  
 760.570  
+ 0.175  
 760.570  
760.570

Apparent error of the levels.

S. Eye, Leveller.



With the other level, begin leveling from the B. M. at the other end of the line following the same instructions except omitting all elevations.

When the two levelers meet, the leveler from the far end of the line take a precise rod reading on some T. P. or B. M. whose elevation has been found by the party that began at the zero end of the line.

Party No. 2 work out all of their elevations.

Both parties continue leveling till each has covered the whole line and all the benches.

Both parties run "Check Levels" between all the benches,—see section 13 of Leveling and Earthwork.

Taking the B. M. at the zero end of the line to be correct, both parties reduce the corrected elevations for all the benches.

Take the half sum of these elevations of bench marks found by each party as their corrected elevations.

Correct all the elevations of stations, plusses, and turning points, between benches to conform to the corrected elevations of the benches.

Agree upon the corrected elevations of every place where a rod reading was taken. If unable to agree at first, both repeat enough of the work on the ground to reach an agreement.

The result will be the corrected levels for this line from which the profile is to be made.

## XII. PROFILE AND GRADE LINE.

### OFFICE WORK.

Each person prepare a profile of the 3000 ft. line of levels. With advice of teachers, each person fix upon a grade line on profile and work out all elevations of grade, including vertical curves.

Follow the instructions in sections 14 to 22 of Leveling and Earthwork.

## XII. STAKING OUT A GRADE.

### 98. Information.

If the last mentioned survey, profile, and grade line, were for a railway, highway, or similar construction, follow Leveling and Earthwork, from section 23 on.

For a canal the work of staking out is similar to that for a railway but the cross sections may be more extended, especially where the canal is enclosed by banks, or where the spoil banks are staked out. However no additional principles are involved more than are given in Leveling and Earthwork.

In making surveys for any excavation over a considerable area, as for a large building, an artificial pond, or for grading, follow the instructions for Borrow Pits given in sections 41 and 45 in Leveling and Earthwork. For filling a piece of ground the work is similar. Stakes, or poles, should be set over the area to be filled, as needed, with tops sufficiently above the finished grade to allow for settlement, see Sec. 57 in Leveling and Earthwork.

A survey for a dam, or a similar structure, involves a contour map of the site, as well as a survey similar to that for a railway for a short distance, namely, along the dam itself. If an earth, or rock fill, dam, is to be built the slope on the upstream side may be as flat as 1 on 3, while the slope on the face may be 1 on 2. The whole site for the dam should be covered by borings close enough and carried deep enough, not only to reveal suitable materials for supporting the dam and that will hold back the water from beneath it, but also to reveal any pockets there may be of materials that may prove dangerous. The borings may need to be extended much beyond the site of the dam itself. Frequently not enough borings are made. This is true for any heavy structure. Such should not be undertaken until the knowledge of the materials below ground is as complete and as trustworthy, as the knowledge of those on the surface. The borings may have to be as close as 5 ft. by 5 ft., in extreme cases. Borings should be surveyed and mapped. Then profiles of any materials below the surface can be made out and grades, or sub-grades, fixed upon. In the case of the dam, the contour survey and map may be extended up stream as far as the pond will reach to give the pondage.

For a heavy building, the remarks about borings apply.

The same is true for chimneys, towers, bridge abutments or piers, and any similar structure.

Men do not always remember that the load on any structure, as well as the weight of the structure itself, must at last rest on the ground, and that the ground will not in all instances carry "anything." Still more frequently is it forgotten or disregarded, that the load on each square foot of the materials beneath a structure should be proportioned to the carrying capacity of these materials, if uniform settlement is to be expected. Especially is this true in building where footings beneath posts and piers are made too large for those under the walls. The walls settle more than the piers, floors go out of level, and machines and shafting are thrown out of level. All this may require the

various materials upon which a structure of considerable extent is to rest to be uncovered so as to be examined by the engineer and perhaps tests made by applying actual loads to ascertain the amounts and rates of settlement.

In staking out a grade, set the stakes where they will be convenient for reference by the workmen, where they will not be dug up or covered, where they will stand firm, and be secure from disturbance. The same stakes can sometimes be used for both line and grade, as the "Track centers" on a railway, or those set for a ditch or pipe trench.

On any kind of a ditch, or pipe trench, decide upon which side of it the excavated materials shall be placed, so as to leave the other side clear, for access of men, for materials, and for any work that may be required. Fix upon a berm, or the width of a space, between the excavated materials and the side of the ditch or trench. The berm will depend upon the nature of the materials to be moved, the depth of the digging, the side slope of the work, the weather to be expected, and whether curbing is to be used, or not. Set the grade stakes within this berm,—near its outer edge; If practicable. If the same stakes are used for both line and grade the transit work and leveling must go on together. Decide upon a distance between the center line of the work as marked on the ground, and a line parallel thereto where stakes are to be set by the transit with nails in their tops to mark this parallel line for the use of the workmen. Make this distance even feet, or some simple number, whenever practicable. Give the workmen sticks cut to this distance. This distance may have to be different on different parts of the work.



## XII. STAKING OUT A GRADE.

FIELD WORK. PARTY OF FOUR.

### 99. Outfit.

Transit.

Measuring set.

Line staff.

Axe. 2" x 2" stakes.  $\frac{7}{8}$ " x 2" stakes. Nails. Marking chalk.

Level.

Leveling rod.

Axe. Pegs.

Examine the articles as issued or be liable for defects found upon their return.

### 100. Directions.

A tile drain, a pipe trench, a ditch, or a walk.

Stakes to be set for both line and grade.

Square out a line with the transit from the center line at some station, or transit plug, on it.

Drive a 2" x 2" stake on this squared out line at the distance of the parallel line from the center line.

Drive this stake till it stands plumb and firm.

Drive a small nail in the top of the stake at exact line and distance.

Mark this stake with the number of the transit point, or mark another  $\frac{7}{8}$ " x 2" stake with this number and drive it about a foot to the right of the first.

Set another 2" x 2" stake, measured, lined, and marked, in the same way from some other station or transit plug on the center line.

Run, measure and mark, with 2" x 2" stakes and nails, giving the stakes the same numbers as the stations on the center line opposite which they stand, a line parallel to the center line, based on the two stakes and nails first set.

Check the measurement from one of these stakes first set, by measuring the closing distance to the other. If the measurement is not near enough correct, review the work and correct the errors.

Set up the level. Find H. I. by taking a rod reading on a B. M.

Decide how high above grade the top of any 2" x 2" stake on the line parallel to the center line shall be.

Add this height to the elevation of grade at that place.

Subtract this sum from H. I. for rod reading on the 2" x 2" stake.

Drive the 2" x 2" stake till the rod gives this reading when held up on it. The target may be set at once at the reading, if a target rod is used.

Use the same distance above grade for as long a run as practicable.

Use numbers that will reduce to simple terms in feet and inches.

Reduce the decimal of the rod reading to inches.

Mark the height in feet and inches of the top of the 2" x 2" stake above grade, on that stake, or on the witness stake beside it.

Do the same for each 2" x 2" stake at the time it is being set by the transit party.

Sometimes on a marsh all the grade stakes for a ditch can be set at the same height above grade. Do this where practicable, and give the workmen sticks cut to this height.

## XII. STAKING OUT A GRADE.

### 101. Information.

In grading or paving, a street, stakes must be set as needed and not too many set at one time. Enough of them must be set to define the cross section of the street plainly for the workmen. This may mean as many as seven lines of grade stakes to be carried along the street.

In some street gutters four or five lines of grade stakes may be needed on a seemingly narrow strip of ground.

Grade stakes for curbs, either on streets or elsewhere, are troublesome to keep in place because they must be set close to the curb trench, and be used for line also. Drive two long stakes a little back from the trench, if practicable, and securely nail to them a strip of wood pointing cross wise of the curb and extending to its work edge, face, or corner. Make the end of the stick line and the bottom of it grade. Some times pieces of iron pipe 4 ft. long, or more, can be used for curb grades. Set the top to grade and the outer side parallel to line of curb.

Sidewalk grades in a built up district in a city oftentimes may be marked on watertables, stone steps, window sills, or by spikes or nails in the joints of brick work.

Grade stakes for concrete floors may be small and left in the concrete. They should be set as needed, with their tops to grade.

For grades for buildings, see XIII.

### XIII. STRAIGHT LINE.

#### INFORMATION.

- 102. Rem.** A straight line may be run by fore sights or by back and fore sights. By fore sights marks are set in line with the instrument point and another before it. By back and fore sights marks are set in line with the instrument point and another back of it. This last is much the better way and is one commonly used.

The plate must be level. Keep sharp watch of the plate level parallel to the transit axis.

- 103. By Fore Sights.** Set up the transit over a mark on the line. Set the line of sight on a mark on the line in the direction in which the line is to go. Give line for a mark, as a nail in a plug, beyond the sight mark where it can be seen from the sight mark. While the plug is being driven see if the point of the plumb bob hangs to the mark beneath the transit, see if the plate levels read level, and see if the line of sight strikes the sight mark. Correct the setting of the transit in any, or all, of these particulars, and be ready to give line as soon as the plug is driven. With one more look at the plate level parallel to the transit axis and to see that the line of sight strikes the sight mark, give line for a mark on the plug. See if the line of sight strikes the sight mark. If not, repeat these operations until it will. Give the signal "All right." Release the spindle clamp. Reverse the transit on its spindle and transit axis. Level it if needed. Set the line of sight upon the sight mark. Locate a second mark beside the first with the same tests. Drive a small nail equidistant from the two marks located. The nail will be on the line.

Set up transit over the sight mark. Use the new mark as a sight mark, and continue the line as before.

104. **By Back and Fore Sights.** Set up the transit over a mark on the line. Set the line of sight on a mark on the line in the direction opposite to that in which the line is to go. Reverse the telescope on the transit axis and give line for a mark in advance, as a nail in a plug. While the plug is being driven, see that the point of the plumb bob hangs to the mark under the transit, see if the plate levels read level, and reverse the telescope on the transit axis and see if the line of sight strikes the back sight mark. Correct the setting of the transit in any, or all, of these particulars, and be ready to give line as soon as the plug is driven. With one more look at the plate level parallel to the transit axis and to see that the line of sight strikes the back sight mark, reverse the telescope on the transit axis and give line for a mark on the plug. Reverse the telescope on the transit axis. See if the line of sight strikes the back sight mark. If not, repeat these operations until it will. Give the signal "All right." Release the spindle clamp. Reverse the transit on its spindle. Level it if needed. Reverse the telescope on the transit axis. Set the line of sight on the back sight mark. Reverse the telescope on the transit axis and locate a second mark beside the first, with the same tests. Drive a small nail equidistant from the two marks located. The nail will be on the line.

Set up the transit at the new mark. Use the one where it stood for a back sight mark and continue the line as before.

If the two marks located by either of these methods, as above directed are not at the same distance from the transit, the nail must be driven midway between them. By doing this the first two marks may be at some distance apart along the line, and in case the second mark comes off of the plug set to receive them, a stake may be driven to receive it far enough back, or forward, of the plug, to admit another plug between, without disturbing either, and the nail be driven therein. This will sometimes save considerable time.

If the transit is considerably out of adjustment it may take a wide plug to receive both of the first marks.

If the second of the first two marks comes off of the plug but so close to it that the nail will come on the plug, shove a stout peg into the ground beside the plug, to receive the second mark. This saves time.

- 105. Rem.** In running a straight line use pickets, or sight marks of some kind, for back sighting to. This is better than a line staff, held by a "Back flag man" and may save the services of such a person.

Where a short sight cannot be avoided use a nail, point of a plumb bob, a pencil point, or some similar small thing to sight to, either forward or backward. The nail and paper mark is a good one, only use a small nail.

When sights must be short and obstructions in the way use a plumb line, of suitable length and fineness to sight to. It may be held steady by sticking the line staff, or a long stake, in the ground obliquely, and grasping it high enough up with the hand holding the plumb line. By changing the inclination of the staff the bob may be held over a mark or brought into line from the transit.

When running a straight line, set one pair of opposite leveling screws on the line. The other pair will then stand across the line, and in the best position for keeping the plate level tube parallel to the transit axis reading level. This level tube is the more important of the two, in this work. It should be closely watched and kept reading level. After using the leveling screws for this purpose the reference sight must be repeated.

### XIII. STRAIGHT LINE.

#### FIELD WORK.

- 106. Outfit.**  
 Transit.  
 Line staff.  
 Axe. 6 plugs. 5 pickets. Nails.

Examine the articles as issued, or be liable for defects found upon their return.

#### 107. Directions.

Select a place open to the sky, where a straight line can be run for from a half a mile to a mile, and all the pickets be seen from the last plug, as across a valley.

Set five or six plugs, not less than 500 ft. apart.

Use the Back and Fore Sight method.

If possible refer the line to some distant mark, or object, in the rear.

Set up the transit where it is proposed to place the first plug. Back sight to the distant mark.

Reverse the telescope on the transit axis and see if the line of sight ranges along the ground where it is proposed to lay out the line.

If not, shift the transit until it fits this range.

Drive the first plug and nail in it accordingly. Leave a picket there.

Set up the transit over this first nail.

Back sight to the distant mark, or place one 500 ft. or more, to the rear for this purpose.

Set the second plug and nail not less than 500 ft. ahead on line by the back and foresight method. Leave a picket at the station over which the transit stands.

Set up the picket behind the eyepiece, so it will stand firm.

Put the plumb bob in a pocket, and draw away the transit without disturbing the picket.

Set up the transit over the second nail.

Back sight to the picket at the first plug, and set a third plug and nail not less than 500 ft. ahead on line, as before. Leave a picket there.

Set up the picket at the second plug behind the eyepiece and move the transit to the third nail.

Set up the transit over the third nail.

Continue the line as before until five or six plugs and nails have been set in the manner indicated, always backsighting to the last picket even if all the others can be seen.



Set up the transit over the last nail.

Back sight to the most distant picket, or mark.

See how near, by estimation, the vertical cross wire comes to bisecting each picket in the order of their numbers, 1, 2, 3, 4, &c. Focus the objective sharply on each picket.

Record the distance, as estimated, that the line of sight strikes away from the line of each picket, showing whether it is to the right (R) or left (L) as the line was run.

See if the line of sight still strikes the most distant mark.

If not, repeat the observations till it will and correct the record to conform to the final result.

Release the spindle clamp.

Reverse the transit on its spindle.

Reverse the telescope on its transit axis.

Level the transit, if needed.

Set the line of sight on the most distant mark, and repeat the observations, as before.

Record the results of these observations beside those first obtained.

Calling deviations to the R. +, and those to the L. —, add with their signs the results of both observations at each picket, divide by 2 to get the actual deviation of the line of sight at each picket.

Record these final results, showing which is R. and which L., beside the other records for each picket.

This gives a demonstration of the trustworthiness of the method and the precision with which the whole work has been done.

### XIII.. STAKING OUT A BUILDING.

#### INFORMATION.

#### 108. Rem.

A building of any considerable size, or of an irregular plan, can be more accurately, and cheaply, staked out with a transit and measuring set and a level and leveling rod than in any other way. Besides the work will be more trustworthy.



Examine the plans critically for errors in dimensions,—all of the plans, not merely the foundation plan. See that the sum of the interior dimensions plus the thickness of walls equals the exterior dimensions, everywhere, and in every way, across every part of the building. Record, in full, the results of this examination in the note book, whether errors and omissions are found, or not. If errors, or omissions, are found report them and refuse to begin staking out until the errors are corrected, and all omissions supplied so all the dimensions can be fully verified.

Examine the elevations and sections for the location of all grades, such as sub foundations, footings, watertables, ground surfaces, or any other thing whose height must be known. See if the figures agree. Record, in full, the results of this examination. Report all defects, deficiencies, errors, or discrepancies, and refuse to begin staking out until they are all properly taken care of.

Ask for all needed explanations. On any important building all corrections, changes, additions, or explanations should be given in writing, or be made on the plans. If this is not done, enter in the note book, at once, all such verbal information, with the date, and source, or authority.

Be particular not to begin staking out until all the plans, and such parts of the specifications as relate to the location, levels for, and dimensions of, the building are fully and completely understood. The specifications and plans should agree, or be made to agree, upon these matters.

Too frequently not enough care is taken to make certain regarding the matters above referred to.

Too frequently the engineer is asked to stake out a building in a "Rush." This he should refuse to do, unless he knows the plans and specifications thoroughly before hand, or is relieved of all responsibility for the results of his work by a written and signed release. An engineer should never forget that the word "Rush" stands for mistakes, blunders, trouble, and dissatisfaction, and act accordingly.

Some line on the building should be designated as the one to be staked out. In a masonry building this may be the

brick line, the face of the water table, the face of the foundation wall above ground, or any similar one. In a wooden building it may be the face of the foundation wall, the outside of the frame, or a similar one. There should be room enough on the line boards for laying off spaces for lines for everything outside of the line staked out. Such are watertable, foundation walls, and footings. The same should be true on the inside of the building. There should be room for the thickness of walls, for footings and the like.

Some line on the building should be designated as the one for which the leveler will give the elevation. In a frame building this is commonly the top of the foundation wall. In a masonry building the top of the first floor joists is used, also the top of the water table, the top of the finished foundation wall, or some similar line. The builder can be accommodated in making this selection but there should be a record to show unmistakably what line was used, and its relation to other lines on the building.

### XIII.. STAKING OUT A BUILDING.

#### FIELD WORK.

#### 109. Outfit.

Transit.

Measuring set.

Line staff.

Axe. Short stakes. Nails, 3d, 8d, 10d, and 20d. Mason's line.

2" x 4" scantling.  $\frac{7}{8}$ " x 6" or 8" boards, surfaced and with one edge of each straight.

Carpenter's level. Hand saw. Sledge, maul, or stone hammer.

Shovel or spade. Pick axe, or grub hoe,—surveyor's style. Level.

Leveling rod.

Axe. Pegs. Spikes.

Examine the articles as issued, or be liable for defects found upon their return.

#### 110. Directions.

Mark all of the corners of the buildings by nails in short stakes driven in the ground till firm. Verify the measurements and angles till no more can be done to make sure all of the nails are correctly set.

Stretch a mason's line from nail to nail, taking a turn around each.

See if anything wrong can be found. If so, correct it. Repeat the work till no fault can be discovered.

Set 2" x 4" scantling, as stakes, in the ground, high enough, where practicable, to reach up to, or a little above, the elevation to be given with the level. They should be far enough back from the excavation so as to be in no danger from caving, but at about the same distance from the building. They should stand firm. Drive them with a sledge, or stone hammer. In some ground holes may have to be dug for them. There must be at least two, and may be three, or more, in a group. About a convex corner three or more stakes are set so that boards nailed to them will be about parallel to the faces of the walls meeting there. Similarly for a reentrant corner. No stakes should be set within the limits of the excavation, as a rule. Stakes may be set to hold a board about at right angles with a wall to receive the line for that wall on its projection beyond the stakes.

Nail boards diagonally from near the top of one stake to where another goes in the ground. Tie the stakes together securely in this manner.

With the level and rod mark, on at least one stake in a group, the elevation of the reference line for the levels for the building, as the top of the foundation wall, the top of the water table, or the top of the first floor, joists, or whatever line is used. Check these levels fully.

Find, or make a good B. M. to which the levels for the building are referred. Have this B. M. entirely outside of the work where by no possibility it can be disturbed. Connect this B. M. with another B. M. entirely away from the locality. Record all of these matters.

Nail the straight edge of a board to the level mark on a stake, straight edge up, and set this edge level with the carpenter's level. Nail the board to another stake, and complete the nailing with four nails in a stake. Thus do every where. Saw off the tops of stakes even with the tops of the boards.

Transfer the lines of the building with the transit from the nails in the short stakes in the ground to the top edges of these boards.

Make a slight cut with the saw across the top of the boards at the line marks, only just deep enough to take a mason's line.

While transferring the lines to the boards, extend one, or more, of these lines each way of the building to distant marks that cannot be disturbed, for future reference. Measure carefully from the nails in the stakes first set on any line, each way to these reference marks on that line. Witnesses for the corner marks of the building, accurately measured, may also be used. Record all these matters fully, so the position of the building on the ground, or any line of it, can be quickly replaced.

With a rule draw out a witness mark from each saw cut on the surfaced side of the line boards and plainly write thereon a brief designation of what line of the building the saw cut is on, as "Brick Line."

Look over the tops of all the line boards and see if they are all in the same plane.

Stretch a mason's line in the saw cuts for every line of the building they mark.

Look over these lines with the utmost care for any mistakes, or faults of any kind. They should all lie in the same plane. Measurements anywhere between them should agree with the plans.

Having done everything that can be thought of to insure the correctness and security of the work, including good records of everything whatever, the building must be left for others. If the sills of a wooden building go on the finished foundation walls and fit, or the first course of cut stone work in a masonry building goes on and fits, the anxiety of the engineer should leave him.

### XIII.. STAKING OUT A BUILDING.

#### INFORMATION.

111. **Rem.** On small buildings, projections which are rectangular, polygonal, or circular, and of no great size may be conveniently laid out by templates, it being necessary only to mark the points where the templates join the main structure.

Circular, or polygonal, forms of considerable size may be sometimes laid out by marking their centers within the limits of the excavation and marking the points where they join the rest of the structure. Such centers should be marked in a most substantial manner. An old boiler flue, or piece of 2" or 3" iron pipe, may be driven plumb, the top to the proper elevation, and a plug put in the top on which the center may be marked, and closely witnessed by measurements to other marks as references. Even this may not answer in some cases.

Large, and especially irregular buildings may be laid out by coördinates. This is a satisfactory way because of the numerous checks it furnishes, and they are needed. Select convenient axes of reference. These may be lines of the building itself, or frequently one of them may. In place of axes of coördinates the building may be surrounded by a rectangle that can be laid out on the ground, and points on the plan referred to the sides of this rectangle,—really coördinates. Number all the points on the plan that are to be marked on the ground. Select the principal axis of

reference, anywhere across the building in any convenient direction, or entirely without it, and also the origin of coördinates, or measurements, on this line. Record these facts. From the plans compute and fully verify, beyond a question, the coördinates of every point thereon which is to be laid out. Record the numbers of all of these points with their coördinates against those numbers. Lay out the principal axis of reference on the ground and mark the origin of measurement. Measure off on this line the coördinate along that line of each point of the plan and mark the measurement by a nail in a stake in succession, and lay out a line at right angles with the principal axis. On this line measure the other coördinate of the designated point and mark that point by a small nail in a stake numbered for it. Measure between these nails along the lines of the building. Record the results, and compare them with corresponding dimensions on the plan. They should agree with the plan. This gives one, or more, checks on every line. This method can be used with success to keep a building on a lot barely large enough to receive it, without staking out much, if any, of it.

In the simpler structures the work may be verified as follows: Lay out the controlling angle, or angles, with the transit. Locate the various marks by measurement. Use the transit to test the angles thus obtained. Or, lay out various lines with the transit and locate marks thereon by measurements. Verify the work by measuring closing distances between the marks set in this manner, the same as if the points had been laid out by coördinates, as above outlined.

## TRANSIT ADJUSTMENTS AND TESTS

---

### XIV. PLATE LEVELS.

If found much out, partially adjust the worse one first.

#### 112. Preparation.—

Set up the transit firmly and level it carefully.

#### 113. Test.—

Reverse the transit about its spindle. See if the bubbles read level. Reverse the transit back to its first position. See if the bubbles again read level. Repeat these trials, making the necessary corrections in the setting, or leveling, of the transit, till the bubbles will surely read level again when the transit is returned to its first position. Then reverse the transit, as at first, and note the deviations of the bubbles from level readings.

#### 114. Correct,

by estimation, one-half the deviation of a bubble by means of the screws that fasten the level tube to the plate.

Level the transit carefully again. Test the adjustment as at first. Repeat the corrections and tests, in this manner, till no deviation appears when the test is made.

Check screws upon the adjusting screws of the level tube (sometimes placed in the end plugs of the level tubes) must be released before making the correction. These check screws keep the level tubes longer in adjustment, but may give annoyance in making the adjustment. Do not screw them too tight. Test the adjustment and see that it is correct after the screws are set.



The vernier plate and the limb plate may not be parallel in their motions. This may be tested by first adjusting the plate levels about the spindle with the plates clamped; then releasing the plates and clamping the spindle; and finally testing the adjustment of the plate levels about the axis of the vernier plate. If found out of adjustment with respect to the motion of the vernier plate, after carefully repeated trials, it shows that the two plates do not revolve about the same axis. Leave the plate levels in adjustment with respect to the spindle if the principal work is running straight lines, and reversion on the spindle. If reading angles is the principal work, leave the plate levels in adjustment with respect to the motion of the vernier plate. In case this defect is serious the transit should go to its maker and be recentered.

Should it be found impossible to adjust the plate levels, after repeated careful trials, about either axis of motion, it shows that axis of motion with respect to which this difficulty exists, to be badly damaged. Usually the maker must fix it. Make this test after the transit has had a fall.

## XV. LINE OF SIGHT. CLOSED WYES.

A place to set the transit in is needed where well-defined fixed marks can be readily found on opposite sides of it at a distance away as great as the telescope will show them clearly. It is well to have the marks at about the same angular distance, above on one side and below on the other, from the place chosen. The plate levels should be in adjustment, and the reversions of the transit made about the axis they are adjusted for.

### 115. Preparations.—

Set up the transit firmly in a suitable place. Level it carefully. Set the line of sight on a distant, well-defined,



fixed mark. Reverse the telescope about the transit axis and find a similar mark in apparent line. Turn the telescope back and see if the line of sight strikes the first mark. Repeat these pointings, making the necessary corrections in the setting and leveling of the transit till the line of sight will surely strike the first mark again when the telescope is turned back.

#### 116. Test.

Release the unnecessary clamps and reverse the telescope about both axes. Level the transit if the levels show a slight disturbance. Set the line of sight on the first mark. Reverse the telescope about the transit axis and see if the second mark is in apparent line. Turn the telescope back to the first mark, as before, and, by the same means, make sure the line of sight will strike the mark. Then reverse the telescope, as at first, and note the deviation of the line of sight from the second mark.

#### 117. Correct,

by estimation, one-fourth of the deviation of the vertical cross wire by means of the screws at right angles with it that hold the cross wires in the telescope tube. Whether the telescope shows objects right side up, or not, turn these screws as if to increase the apparent deviation. Loosen the screw permitting the desired movement before turning the other. Leave the screws under a gentle, even, strain. If the deviation is large, loosen the other pair of screws slightly, but have a care not to get the vertical cross wire inclined.

Set the line of sight again upon the first mark, as at first. Repeat the tests, corrections, and tests till no deviation appears when the test is made.

This adjustment is required theoretically in reading angles, but not in running straight lines. It conforms to the best working conditions, however, both optically, and in the field practice.

## XVI. STRIDING LEVEL.

## 118. Adjusting Vertically.

## 119. Preparation.

Set up the transit firmly. Level it carefully by the plate levels, or disc level. Bring the transit axis over a leveling screw. Clamp the spindle. Place the feet of the striding level on the bearings for them on the transit axis. Level the striding level with the leveling screws to the transit. See that it stands freely on its feet, and remains level.

## 120. Test.

Carefully lift up the striding level, reverse it, and replace its feet to the bearings, without jar. In the same manner return this level to its first position. See if the bubble again reads level. Repeat these reversions, making the necessary corrections in the setting or leveling of the transit till the striding level bubble will surely read level again when returned to its first position. Then reverse the striding level as at first, and note the deviation of the bubble from a level reading.

## 121. Correct,

by estimation, one-half of the deviation by means of the adjusting screw, or screws, at one end of the level tube, provided for a vertical adjustment.

Set the striding level, by means of the leveling screws of the transit, to read, and stand, level again. Test adjustment as at first. Repeat the corrections and tests, in this manner, until no deviation is shown by the test.

In making this adjustment stand the striding level vertically over the bearings. Do not incline it. If inclined it may show this adjustment apparently imperfect. This requires a second adjustment sidewise to bring the axis of the level tube into a plane parallel to the line of the points of support of the feet of the striding level.

122. Adjusting sidewise.

123. Peperation.

Make the last adjustment as perfect as practicable.

124. Test.

Incline the striding level slightly on its feet. Return it to its first position. See if the bubble again reads level. Incline it in the opposite direction about the same amount. Return it again to its first position. See if the bubble again reads level. Repeat these trials, making the necessary corrections in the setting or leveling of the transit, till the bubble will surely read level again when returned to its first position, and stand at the same reading when inclined. Then incline the striding level, as at first, and note the deviation of the bubble from a level reading. Incline it a like amount in the opposite direction and note the deviation.

125. Correction.

By means of the screws for a sidewise adjustment set the level tube so it will show the same deviation in the same direction for the same inclination either way from its vertical stand, when tested as above described.

The bubble should read level in all three positions. If it does not the bore of the glass tube is not uniform, and it should be replaced by a perfect one at the first opportunity. In using such a striding level be very careful to stand it plumb on its feet.

This adjustment, and the preceding, need to be made alternately together when first the bubble tube is attached to its base.

If, for any reason, the bubble tube has to be disconnected from its base, loosen but one of the sidewise screws and notice how tight it is. Likewise, if there is a check screw to the vertical adjustment, leave it alone,—only unscrew the adjusting screw. When the bubble tube is again restored to its connections with its base it can be set almost in its proper place by bringing the loosened screws to their bearings again, and not require so much adjustment.

## XVII. TRANSIT AXIS TRUNNIONS. ROUNDNESS.

## 126. Preparation.

Separate the transit axis from the telescope. Clean its trunnions and their bearings in the wyes of the transit. Set up the transit firmly in a place of an even temperature. Level the transit carefully. Clamp the spindle so the transit axis will stand over a leveling screw. Place the transit axis in its wye bearings. Stand the striding level on the transit axis with its feet on the trunnions. Level the striding level carefully with the leveling screws to the transit. Reverse it and put it in adjustment. Level the striding level carefully again and see that everything is stable, and steady, so the striding level will stand level.

## 127. Test.

Lift the striding level off. Replace it carefully. See if it reads level again. Repeat this test, making any corrections that may be needed in the setting or leveling of the transit, or adjustment of the striding level, or otherwise, till the bubble of the striding level will surely read level again when replaced, and stand level.

Lift the striding level off. Turn the transit axis slightly in its bearings. Replace the striding level as before,—do not reverse it. Notice if it still reads level. Remove the striding level; turn the transit axis back to its first position; replace the striding level, as before; and see if it again reads level. Repeat this test; make sure of the stability of the apparatus, and of the reading of the bubble of the striding level after the transit axis is turned.

So test the transit axis by turning it a little more at each trial till it has been examined entirely round its trunnions and returned to its first position.

Whenever the striding level fails to read level in these tests it shows that the trunnions are not round.

Theoretically, this method will not show which trunnion is not round, but in practice a marred trunnion is easily

found by looking for the defect shown by the striding level. In any case this method may be used to prove the trunnions to be round. By providing a support for one foot of the striding level while the other rests on a trunnion, that trunnion can be examined separately. Usually the transit axis must go to the maker to be refitted, and the transit may have to go with it. The finest transits must always go to the maker for this defect to be removed. The trunnions of the transit axis of a transit of not as fine a grade have been smoothed and made of the same size by soft wood clamps, oil, flour of emery, and turning the transit axis by hand, while a trunnion was held in the clamps where the oil and emery had been applied. This was so successfully done that the striding level in use with the transit would show no difference of any kind between the two trunnions. Such a thing is not recommended for general practice, but may serve when nothing better can be done, except at a great loss of time and much expense. When emery is used in any form about an instrument, the utmost care must be taken to get rid of it all. It is so liable to do most serious injury to the moving parts that its use is prohibited by many persons and tripoli, or even pumice, substituted. Nothing coarser than flour of emery should ever be used.

## XVIII. TRANSIT AXIS TRUNNIONS. EQUAL SIZE.

### 128. Preparations.

Open the wye clips; take out the transit axis; and clean the trunnions and their bearings in the wyes. Set up the transit firmly. Level it carefully. Clamp the spindle so the transit axis will stand over a leveling screw. Place the transit axis in its wye bearings. Stand the striding level on the transit axis with its feet on the trunnions. Level the striding level carefully, with the leveling screws of the transit. Reverse it and put it in adjustment. Level the striding level again as at first. See that everything is stable, and steady, so the striding level will stand level.

**129. Test.**

Set the striding level off. Lift out the transit axis carefully, reverse it, and replace it in the wyes without jar. Replace the striding level without reversing it. Notice if it still reads level. Remove it as before. Restore the transit axis to its first position without jar. Replace the striding level. See if it again reads level. Repeat these trials. Make sure of the stability of the apparatus and of the reading of the level when the transit axis is reversed.

If the level does not read level when the transit axis is reversed it shows the trunnions to be of different sizes. They must usually be fitted by the maker, but may be treated as noted in XVII. This method tests for differences in size. Should a difference be shown, the trunnions are not made with precision enough for the striding level, or the level is too sensitive for the transit.

Professor Durand's three-point calliper may be made to give still more delicate tests for roundness and differences in size.

Theoretically this test will show whether the two trunnions have a common axis. Practically, this defect would have to be so large as to be a disgrace to shops of the present day, for it to appear. Trunnions are turned to the same size, even when using the term size with rigid precision. That is, the trunnions are so nearly of a size that if the tests appear to show a difference, that difference is quite likely due to the errors of the test (observation, apparatus, temperature, etc.), instead of to the difference in size of the trunnions. Some very elaborate tests would seem to confirm this view.

A level bubble can be read with as much more precision, with a reading glass than without, as the graduations of the plate can.

## XIX. LEVELING THE TRANSIT AXIS.

Set up the transit and level it carefully with the plate levels.

Stand the striding level on the transit over a leveling screw. Level the striding level carefully with the leveling screws of the transit. Reverse it and put it in adjustment. Level the striding level as at first. See that everything is steady so the striding level will stand level. Turn the transit one-quarter round on its spindle axis and level the striding level again. Turn the transit back to its first position,—do not reverse it. Level the striding level. By repeated trials set the transit, by means of the leveling screws, so the striding level will stand level in either position of the transit. Test the striding level again for its adjustment. Repeat these operations till the striding level shows the transit axis to be level in both positions of the transit and itself is in adjustment at the final test.

The transit axis will then be level, but the spindle axis will not be vertical unless these axes are in adjustment. This adjustment is given in XXII. It may be tested and made at the time of leveling the transit axis by the second method given for this adjustment in XXII. Then the transit will be completely leveled by means of the striding level. It will be much more precisely set than any plate levels can set it. In the better grades of transits, the plate levels are for approximate setting only.

## XX. LINE OF SIGHT. OPEN WYES.

Select a place for making this adjustment in, from which a well-defined, fixed mark can be seen when the telescope is pointed level, or nearly so, and as far away as the telescope will show it plainly. Use the striding level to the transit axis. The trunnions of the transit axis must be round, of the same size, and centered on the same axial line.



**130. Preparations.**

Set up the transit firmly in a suitable place. Open the wyes. Level the transit axis carefully with the striding level as directed in XIX. Set the line on a distant, well-defined, fixed mark, with the transit axis leveled. Remove the striding level.

**131. Test.**

Carefully lift the telescope from the wyes; turn it over, the objective directed towards the mark, and replace it in the wyes without jar. Replace the striding level and see if the transit axis still stands level. Remove the striding level. Restore the telescope to its first position. Replace the striding level. See if the line of sight again strikes the mark and the transit axis is level. Repeat these trials, making the necessary corrections in the setting or leveling of the transit, or the adjustment of the striding level, till sure that the transit axis stands level in both positions, and the line of sight strikes the mark in its first one. Leave the telescope in its second position. Notice the deviation of the line of sight from the mark.

**132. Correct**

one-half of this deviation by means of the cross wire screws at right angles with the vertical cross wire, as directed in XV.

Set the line of sight again upon the mark, as at first. Repeat the preparations, tests, corrections, preparations and tests, till the test shows no deviation.

This adjustment can be made in the way described in XV for closed wyes, when the telescope can be reversed on the transit axis.

**XXI. AXES. CLOSED WYES.**

The plate levels should be in adjustment. The line of sight should be in adjustment. The objective slide should be



in good line. If the transit has a telescope level, or other delicate level, it should be leveled by it as directed in XXII or XXIII. In making this adjustment, the telescope should be turned through a vertical angle of about  $90^\circ$ ,—from about  $45^\circ$  above, to about  $45^\circ$  below, the horizon.

### 133. Preparations.

Set up the transit firmly near some high, well-defined, fixed mark, so that when the telescope shall be directed to it the elevation will be about  $45^\circ$ . Level the transit carefully, as above noted. Set the line of sight on the high mark. Read, or estimate, the angle of elevation. Direct the telescope at the same angle below the horizon, on the same side of the transit. Find, or fix, a mark in apparent line. Turn back to the upper mark and see if the line of sight again strikes it. Repeat the pointings at both marks, making the necessary corrections in the setting and leveling of the transit, and in the position of the lower mark, till sure the line of sight will strike both marks with the transit carefully leveled.

### 134. Test.

Release the necessary clamps. Reverse the telescope about both axes. Set the line of sight upon the upper mark. Notice if the transit is still level. If not it must be reset, the levels adjusted if need be, and the whole preparation repeated. Having made sure of the setting of the transit and the pointing of the line of sight, direct the telescope downwards, as before, and find, or fix, a second mark in apparent line, with the same care, and tests, used in locating the first mark. See if the two lower marks are the same, or in exact line. Leave the telescope so as to show this.

### 135. Correction.

Move the vertical cross wire over one-fourth of the apparent distance between these two lower marks, by raising, or lowering, one end of the transit axis, by the device provided.

Prepare for and make a test of the adjustment, as at first. Repeat these tests, corrections, and tests, till the test shows the lower marks in the same line, or as one.

This adjustment sets the axes at right angles with each other. It, theoretically, enables one to measure correctly the angle between the vertical planes of lines having very different angles of elevation.

## XXII. AXES. OPEN WYES.

The axes may be adjusted in the way given for closed wyes in XXI. This process involves leveling the transit with the striding level independently of the adjustment of the axes, which adjustment is involved in the usual process of thus leveling the transit. If the striding level feet do not stand on the transit axis trunnions, use the process for adjusting the axes given below. If the transit has a delicate level attached it may be leveled by that, according to the next paragraph, or according to XXIII.

### 136. Leveling with the Transit Axis Striding Level.

Set up the transit firmly and level it carefully with the plate levels. Place the striding level in position. Turn the transit on its spindle so the striding level will stand over a leveling screw. Level the striding level carefully with the leveling screws to the transit. Turn the transit one-quarter round and level the striding level again. Turn the transit back to its first position,—do not reverse it. Level the striding level again. Turn the transit to its second position,—do not reverse it. Level the striding level again. By repeated trials set the transit by means of its leveling screws so the striding level will read level in either of these positions.

Reverse the transit on its spindle. Notice the reading of the striding level. Reverse back again and see if the striding level now reads level. Repeat these reversions, making the necessary corrections in the setting or leveling of

the transit, till the striding level will certainly read level in the first position and return to the same reading always in the reversed position of the transit. Leave the transit reversed. Note the deviation of the bubble of the striding level from a level reading.

### 137. Correct

one-half this deviation by the vertical adjusting screw of the striding level tube.

Repeat the leveling as first noted above, then the reversions, and make any further correction that may be needed in the setting of the striding level tube by its vertical adjusting screw, as before.

Continue these operations till the striding level will read level in both positions of the transit when it is reversed.

By the same means set the striding level so it will read level when the transit is turned one-quarter round, and reversed, as before.

Proceed with these experiments till the striding level is set to read level in any position of the transit when turned around on its spindle, or, speaking theoretically, till the striding level will stand level during a complete revolution of the transit on its spindle.

The spindle will then stand plumb. The striding level will be adjusted to the spindle and not to its feet by this process. Any such delicate level on the transit may be treated and used to level the transit by. The telescope level or the vernier level, being provided with a slow-motion screw, may be set by that instead of an adjusting screw as above described. This is detailed in XXIII.

### 138. Adjusting the Axes. First Method.

### 139. Preparations.

Set up the transit firmly near some high, well-defined, fixed mark, so that when the telescope shall be directed toward it the elevation will be about  $45^{\circ}$ . Level the transit as directed above or in XXIII. Set the line of sight on the high

mark, noticing the level to see that the transit stands steady. Read or estimate the angle of elevation. Direct the telescope at the same angle below the horizon, on the same side of the transit. Notice the level again and see that it reads level. If not, repeat these operations till it does, and both transit and level work satisfactorily. Then find, or fix, a mark in apparent line. Turn back to the upper mark and see if the line of sight again strikes it. Notice the level again and see that it reads level. Repeat the pointings at both marks, noticing the level, and making the necessary corrections in the setting and leveling of the transit, also in the position of the lower mark, till sure the line of sight will strike both marks with the transit carefully leveled.

#### 140. Test.

Release the necessary clamps. Reverse the telescope about both axes. Set the line of sight upon the upper mark. Notice if the transit is still level. If not, it must be reset and leveled as directed above or in XXIII. Having made sure of the setting of the transit and the pointing of the line of sight, direct the telescope downwards as before, and find, or fix, a second mark in apparent line, with the same care, and tests, used in locating the first mark. See if the two lower marks are the same, or in exact line. Leave the telescope so as to show this.

#### 141. Correction.

Move the vertical cross wire over one-fourth of the apparent distance between these two lower marks, by raising or lowering one end of the transit axis by the device provided. Prepare for, and make a test of the adjustment, as at first.

Repeat these tests, corrections, and tests, till the test shows the two lower marks in the same line, or as one.

These processes will reveal defects of construction that can be shown by the striding level. For this reason the examinations noted in XVII and XVIII should be the first made. Leveling with the striding level will not show a difference in size of the transit axis trunnions.

## 142. Adjusting the Axes. Second Method.

### 143. Preparations.

Set up the transit firmly and level it carefully with the plate levels. Place the striding level in position. Turn the transit on its spindle so the striding level will stand over a leveling screw. Level the striding level carefully with the leveling screws to the transit. Remove the striding level, reverse it, and replace it, as in adjusting it. See if it is much out of adjustment. If it is, adjust it approximately.

Level the striding level carefully with the leveling screws to the transit. Turn the transit one-quarter round and level the striding level again. Turn the transit back to its first position,—do not reverse it. Level the striding level again. Turn the transit to its second position,—do not reverse it. Level the striding level again. By repeated trials set the transit, by means of its leveling screws, so the striding level will read level in either of these positions.

Adjust the striding level by the process of XVI, as perfectly as possible.

Level the transit again, as above directed. Test the adjustment of the striding level. Repeat these operations till sure the transit stands steady, the striding level is in nice adjustment, and that it reads level in either position of the transit.

### 144. Test.

Reverse the transit on its spindle. Notice the reading of the striding level. Reverse back again and see if the striding level still reads level. Repeat these reversions, making the necessary corrections in the setting, or leveling of the transit, or adjustment of the striding level, till the bubble will certainly read level in the first position of the transit, and always return to the same reading in the reversed position. Leave the transit reversed. Note the deviation of the bubble of the striding level from a level reading.

**145. Correct**

one-half this deviation by raising, or lowering, one end of the transit axis, by the device provided.

Prepare for and make a test of the adjustment, as at first. Repeat these tests, corrections, and tests, till the test shows the striding level always to read level. Last of all try the striding level for adjustment on its own feet. If not in adjustment repeat the work.

This is the usual way of leveling the transit; leveling the transit axis, adjusting the axes; and adjusting the striding level, all at one time.

**XXIII. TELESCOPE LEVEL TUBE.**

Telescope level tubes are attached by nuts permitting a vertical motion at each end of the level tube, and without any sidewise adjustment, such as is commonly seen on the wye level, and on striding levels. This makes it important that these level tubes be carefully set by the maker, and that the glass bubble tube be placed, and fastened, in its brass case with every care. Striding levels are used, fitting on collars turned on the body tube of the telescope. These may be adjusted in every particular. They are very easily attached and detached, will not fall off, and can be left on the telescope when it is either side up. The ability to completely adjust them makes them more desirable than the old form, even if provided with a double ground bubble tube, reading either side up, which is protected by a loose brass shell outside the brass case of the bubble tube. All such bubble tubes should be scaled directly on the glass itself, not by a brass scale standing over it.

This adjustment is for the purpose of setting the level tube, or the horizontal cross wire, so the bubble will read level when the line of sight is horizontal. With the level tube attached to the telescope body tube, as first above noted, the level tube is adjusted and there is no very good way of setting the horizontal cross wire in its best position in



the telescope. With the striding level no aid is required—one can make the adjustment alone.

To adjust the attached telescope level there are three principal steps. First, leveling the transit with the telescope level. Second, setting the line of sight horizontal. Third, setting the level tube and testing the adjustment. This method of leveling the transit is necessary or the adjustment of the delicate telescope level would be made to depend upon the plate levels.

#### 146. Leveling the Transit.

Set up the transit firmly. Level it carefully with the plate levels. Set the telescope level tube to read level by means of clamp and slow motion screw to the transit axis. Reverse the transit on its spindle. Notice the telescope level reading. Reverse back. See if the telescope level reads level again. If not, set it to read level again. Reverse the transit again and notice the telescope level reading. Continue these reversions, making the necessary corrections in the setting of the transit and the telescope level, till it will certainly read level in the first position of the transit, and return to the same reading always when the transit is reversed. Leave the transit reversed. Note the deviation of the bubble of the telescope level from a level reading.

#### 147. Correct

one-half of this deviation by the slow-motion screw to the transit axis.

Level and reverse the transit again, as before.

Repeat these operations till the telescope level will read level in either the first, or reversed position, of the transit.

Turn the transit one-quarter round and level it again, as above set forth.

By repeated trials, making the necessary corrections in the setting of the transit and the telescope level, as above directed, make this level read level for any position of the transit when turned on its spindle.

**148. Setting the line of sight level.**

Level the transit as above directed. Leave the telescope clamped. Measure off, each way from the center of the transit, the same distance, say 150' or 200', and drive a stake till firm, at the end of each measurement. Number these stakes  $1$  and  $2$ . See that the transit is level and stands steady. Take accurate rod readings on the tops of the stakes. Subtract the reading on  $1$  from the reading on  $2$  and preserve the sign of the result,  $+$  or  $-$ . Call this result  $k$ .

Move the transit to a place, a short distance, say 30', beyond stake  $1$ , carrying the telescope clamped as last used. Set up the transit here and level it as before. Take a rod reading,  $r_1$ , on stake  $1$  and another  $r_2$ , on stake  $2$ , just as the first ones were taken. Record these with their numbers. Find  $r_2 - r_1$ , noting the sign. Call this  $k'$ . See if  $k = k'$ . Make sure of the whole work.

If  $k = k'$  the line of sight is horizontal and the level tube in adjustment. If  $k'$  does not equal  $k$ , measure the distances from the transit's center to stake  $1$ ,  $d_1$ , and to stake  $2$ ,  $d_2$ . Find a rod reading,  $R_2$ , for stake  $2$  by the following equation, observing all signs:

$$R_2 = r_2 + \frac{k - k'}{d_2 - d_1} d_2 \dots \dots \dots (1)$$

Hold up the rod on stake  $2$  (set at this reading,  $R_2$ , if a target rod), and by means of the slow-motion screw to the transit axis, set the line of sight so it will give the rod reading,  $R_2$ , on stake  $2$ .

Test by taking a new rod reading,  $R'_1$  on  $1$ . Find  $R_2 - R'_1$  observing the sign of the result. See if the result equals  $k$ .

Proceed with these trials and tests till the line of sight is set so that  $R_2 - R'_1$  at a test, equals  $k$ , or so near it that the experiments show it to be useless to try further.

**149. Setting the level tube.**

Set the level tube to read level by means of the nuts at one end of it. Start that nut first that will permit the desired movement. Leave the nuts under a gentle even strain.



**150. Test**

the level tube adjustment by additional rod readings and finally set it so that  $R_2 - R'_1 = k$  when the bubble stands level,—or as near this condition as can be.

If the ground is near enough level, drive the stakes so the first rod readings on them will be equal. Then  $k = 0$ . Proceed as above directed after that, but use the equation below instead of (1) observing all signs.

$$R_2 = r_2 - \frac{k'd_2}{d_2 - d_1} \dots \dots \dots (2)$$

With some experience in making this adjustment, probably the equations will be dispensed with.

**151. Double ground level tube.**

Adjust as directed above, using but one side. Release the necessary clamps; reverse the telescope about both axes; and set the line of sight horizontal by means of the rod reading on stakes 1 and 2. See if the bubble of the telescope level reads level. Repeat the observations and rod readings sure the line of sight is level, the transit steady, and the bubble gives the same reading. Note the deviation of the bubble from a level reading.

Set the bubbles to read level by means of the slow-motion screw to the transit axis. Take a rod reading on stake 2,—the distant stake.

Move the horizontal cross wire by means of the screws at right angles with it, that hold the cross wires in the telescope tube, and set it so the rod reading at stake 2 will equal the half sum of the former rod readings on this stake,—the one when the line of sight was level, and the one when the bubble read level. Whether the telescope shows objects right side up or not, turn these screws as if to increase the apparent deviation of the second rod reading from the first. Loosen the screw permitting the desired movement before turning the other. Leave the screws under a gentle, even strain. If the difference be-

tween the two rod readings is large, loosen the other pair of screws slightly, but be very careful not to turn the cross wire ring. Be certain the transit stands steady and the rod readings are correct.

Set the line of sight again level by means of rod readings on both stakes.

Set the level tube to read level by means of the nuts at one end of it. Start the nut first that will permit the desired movement. Leave the nuts under a gentle even strain.

Test the level tube adjustment by additional rod readings and finally set it so that  $R_2 - R_1 = k$  when the bubble stands level, or as near this condition as may be.

Release the necessary clamps, and reverse the telescope about both axes. Set the line of sight level by rod readings on both stakes. See if the bubble of the telescope level (now the same side up again as at first adjusted), reads level. Repeat the observations and rod readings till sure the line of sight is level, the transit steady, and the bubble gives the same reading. Note the deviation of the bubble from a level reading.

If this is considerably less than before, for the other side of the bubble tube, make the same observations and adjustments for this side, as above detailed for the other.

Release the necessary clamps, reverse the telescope about both axes and make the test just above noted, anew for the side of the bubble tube which is again uppermost.

Repeat these trials, adjustments, and tests, till the telescope level, and the horizontal cross wire, are so set that the line of sight will be level when the bubble reads level whichever side up the bubble tube may be, as shown by rod readings on both stakes.

If persistent trial under favorable conditions of light, seeing, temperature, and steadiness, does not complete these adjustments so they will bear the test imposed or very nearly so, repeat the work and make these adjustments so the two sides of the bubble tube will read the same (not a level reading), when the line of sight is level. Record this reading, and fasten it in the transit box.

By these last adjustments the horizontal cross wire is set nearer its proper place in the telescope tube, if not at that place. The trouble of these adjustments shows the value of such a level tube in such a place. Once the level tube is proven to be ground alike on both sides it makes matters somewhat easier. Even with a perfect level tube there can be no sidewise adjustment and the device is not nearly as perfect as that of a striding level standing on collars turned on the body tube of the telescope.

#### XXIV. HORIZONTAL CROSS WIRE. STRIDING TELESCOPE LEVEL.

##### 152. Preparations.

Set up the transit firmly. Level it carefully with its plate levels. Clamp the spindle so that the telescope will stand over a leveling screw. Clamp the telescope level,—as shown by its striding level. Adjust the striding level as directed in XVI. Level the transit by means of the telescope level as directed above. See, at the last, that the striding telescope level remains in adjustment with respect to its own feet.

Direct the telescope to some object and find a mark on it in line with horizontal cross wire when the transit is carefully leveled by the telescope level, and that level is in good adjustment. Prove the steps and make sure the conditions are favorable.

##### 153. Test.

Release the necessary clamps. Reverse the telescope about both axes, and set it level as before. Be sure the striding level keeps its adjustment. Note the deviation of the horizontal cross wire from the mark it covered before.

##### 154. Correction.

Move the horizontal cross wire by means of the screws at right angles with it, that hold the cross wires in the teles-

cope tube, and set it so it will cover a place midway between the two marks above noted, when the telescope is level. Test the adjustment as at first. Repeat the test, correction, and test, till the horizontal cross wire will cover the same mark with the telescope either side up, and level. This arrangement of a telescope level is the best for general use. The same striding level may be made to fit the transit axis also.

## XXV. VERTICAL CIRCLE VERNIER.

If the telescope is provided with a level, as above noted in XXIII or XXIV, it may be put in adjustment, or the horizontal cross wire adjusted, as directed in XXIV; the line of sight set horizontal; and the vernier of the vertical circle set to read zero when the line of sight is level. This is best, when practicable.

Some transits have a vertical arc in the place of a full circle. Some have two opposite verniers to the vertical circle, some but one. Some transits have two opposite verniers and two opposite sectors of a vertical circle fitting these verniers. With opposite verniers an examination should be made to ascertain if the verniers given readings at  $180^\circ$  apart, or sufficiently near so,—that is within a reasonable limit of instrumental precision, temperature, perfection of construction, and closeness of reading considered. This will be ascertained by taking numerous readings on different parts of the circle, or opposite sectors, both direct and reversed, and comparing them.

If the transit has no telescope level, and but one vernier to its vertical circle, or the verniers and circle, or opposite sectors are not well centered, and in good working order, this adjustment must be made by the peg method given for the telescope level in XXIII,—the leveling being done by the plate levels. This adjustment then must depend upon

the least sensitive of the plate levels,—the one parallel to the telescope. To provide against this, a delicate level is attached to the bar carrying the opposite verniers, on transits having such, which is controlled by a slow motion screw similar to the one used for the transit axis. This level may be used to level the transit with, as directed in XXIII. These conditions call for several forms of this adjustment, as was the case with the telescope level. These are indicated above, except the one given below.

**155. Full vertical circle. Opposite verniers.**

**156. Preparations.**

Set up the transit firmly. Level it carefully by the plate levels. Complete the leveling by the level for the verniers of the vertical circle, if there is one, as directed in XXIII. Set the vertical circle to read, Vernier A,  $0^{\circ}00'00''$  and Vernier B,  $180^{\circ}00'00''$ . Turn the transit on its spindle; direct the telescope to some object; and find a mark in line with the horizontal cross wire. See that the transit is steady and the levels to be trusted.

**157. Test.**

Release the necessary clamps, reverse the telescope about both axes; see that levels show the transit to be steady and leveled, and set the vertical circle to read Ver A,  $180^{\circ}00'00''$  and Ver. B,  $0^{\circ}00'00''$ . Note the deviation of the horizontal cross wire from the mark at first in range with it. Repeat the steps of this process till sure of the result shown. Leave the transit so the telescope shows the deviation.

**158. Correction.**

Set the line of sight midway between its two pointings, by means of the slow motion screw to the transit axis. Set the verniers by means of their slow-motion screw or such other device as is provided, to read  $0^{\circ}00'00''$  and  $180^{\circ}0'00''$ , or one at  $0^{\circ}00'00''$ , and record the readings of both. Fasten these last readings in the transit box.

Set the level to the verniers to read level, if there is one, after setting to read  $0^{\circ}00'00''$  and  $180^{\circ}00'00''$  as above.

Test the adjustments as at first. Repeat the preparations, tests, corrections, preparations, and tests, till the line of sight will strike the same mark whichever side up the telescope may be when the verniers are set for a level line of sight, and the transit carefully leveled, or as nearly as can be to these conditions.

## XXVI. LINE OF SIGHT.

If a transit has a telescope level attached to its body tube, it being in adjustment in respect to the line of sight and it is necessary to adjust the vertical cross wire, as in XV, some work may be saved by leveling the transit for that adjustment with the telescope level, setting the line of sight level, and observing some mark in line with the horizontal cross wire, before beginning the adjustment of the vertical wire. After the vertical wire is adjusted set the horizontal wire on the same mark, first seeing that the transit is as well leveled as before, and adjust the telescope level to read level again, in case it needs it.

The same is true for the vernier, or verniers, to the vertical circle.

It is especially easy to derange the cross wires whenever all four cross wire screws are loosened.

If the telescope level is a striding level it is so little work to adjust the horizontal cross wire that it had better be done instead of depending on any such device as here given.

## XXVII. CENTERING THE EYE-PIECE.

This is for the purpose of clear vision, as one might center a magnifying glass more carefully over an object to be viewed. Frequently there is no way provided for making this adjustment, and none is needed.

Set up the transit where the telescope can be directed to the light,—artificial light will do. By means of the four screws like, or similar, to the cross wire screws, that hold the ring in the body tube of the telescope, in which the inner end of the eye-piece slides, set that ring so the cross wires divide the field of view symmetrically.

### XXVIII. THE OBJECTIVE SLIDE.

No adjustment of the objective slide should be needed. At this point the skill of the maker should be manifest. A test is given below instead of an adjustment. This test will indicate how perfectly the slide is fitted, if the objective is well mounted, or how well the objective is mounted if the slide is well fitted. Two imperfections may be present, or but one of them. An adjustment does not correct the difficulty. It partly hides it.

Set the transit where a row of stakes can be lined by it without a motion of any kind except changing the focus of the objective. Clamp the telescope securely with respect to all its motions. Line out a row of stakes, at measured intervals of fifty feet, to 1,000 or 1,500 feet away. Use a foresight, either at the end of the line, or beyond it, to keep the transit steady by. Mark points on these stakes precisely in line, and at the measured distances apart.

Move the transit to the other end of the line and by trial set it so the line of sight covers the end marks, with no motion but focussing the objective. Leave the telescope so clamped. Line a new set of points at the same places as before. Note their deviations. There should be none, theoretically.

This test is with respect to line. A similar test with respect to level may be made by setting points on the sides of tall stakes in the line of the horizontal cross wire. The horizontal cross wire cannot be easily set to cover the end marks in the second position of the transit. Set the telescope, by means of the slow motion screw to the transit ax-



is, so the line of sight, by the horizontal cross wire, will pass at equal distances from, and on the same side of, the end marks. Make a new line of marks. Measure the spaces between these and the former marks. They should be equal, theoretically.



## TOWN, CITY AND VILLAGE PLATS

### INSTRUCTIONS RELATIVE TO MAKING AND FILING IN THE STATE OF MICHIGAN.

The following suggestions, forms, and extracts from the laws governing the making and filing of land plats are compiled for the information and benefit of surveyors and other interested parties. Act. No. 309 Laws of 1887 (§3372 and §3373 C. L. of 1897) §3372 as amended by act 114 of the P. A. 1909, took effect September 1st, 1909, and all plats made on or after that date must be in conformity therewith.

1. In making the SURVEY it is required that PERMANENT MONUMENTS shall be located in the ground at all angles in the boundaries of the land platted, and at all the intersections of streets or streets and alleys as shown on the map or plat, and when there are permanent objects in the vicinity of such monuments the bearings and distances of such objects shall be noted. The character and dimensions of the monuments and the bearings and distances of such witness points or objects shall be distinctly given in the most convenient manner on the plat. The exact position of the monuments should be indicated on the plat by a small circle "O" or cross "X" and such monuments MUST NOT BE OF WOOD. They are to be PERMANENT.

2. If the plat be of a town, city or village, the full name of such town, city or village must appear as the title or name of the plat; if the land platted be an addition to or a subdivision of a town, city or village already platted, then let the title of the plat include, with the name of such addition or subdivision, the name of the town, city or village, as the case may be, of which such platted land is a subdivision, or to which it is an addition. The name of the county in which land platted is situated should appear under the title.

3. The plat must be on a scale showing not more than two hundred feet to an inch, and on good muslin-backed paper 18x24 inches in size; ALL CERTIFICATES MUST BE WRITTEN OR PRINTED ON THE PAPER ON WHICH THE PLAT IS MADE, AND ON THE SAME SIDE OF THE SHEET.

4. The sections and parts of sections platted must be designated by lines with appropriate letters and figures. In case of a subdivision of lots or blocks of a previous survey, the outlines of the original or previous lots or blocks so subdivided must be designated by lines, which must be marked with appropriate letters and figures. This must be done in such a manner as to show without reference to the written description, the starting point and the course and length of each of the outlines. Where any of the outlines are identical and coterminus with the lines of a previous survey or plat, it will be sufficient to give the destination of such outlines as given in such previous survey or plat.

5. The land platted is to be fully described IN WRITING OR PRINTING upon the paper on which the plat is drawn. This description must be so complete that from it, without reference to the plat, the starting point can be determined and the outlines run. In connection with the description should be a short and simple form of dedication, which must be signed by the proprietors and their wives, whose signatures must be witnessed, and whose execution of the dedication must be acknowledged as deeds conveying land are required to be witnessed and acknowledged.

6. There must be drawn upon the plat a plain designation of the cardinal points and a correct scale.

7. Where all the lots in a block have the same dimensions, it shall be sufficient to mark the precise length and width upon one tier thereof, but all gores, triangles, or other lots, which are not either squares or parallelograms, shall have the length of their sides defined by figures.

8. The streets must be named or numbered and their course and width designated. All public grounds and alleys must be properly designated.

9. The surveyor must certify that the plat is a correct one and that the monuments described in it have been planted as therein described.

10. Detached parcels cannot be included in one plat, nor can more than one plat be made on one sheet. Contiguous parcels owned by different parties may be embraced in one plat, all joining in the execution and acknowledgement; it is not necessary to specify the particular parcels belonging to each.

11. Before a plat shall be forwarded for approval, and before any copies are made therefrom, there must be INSCRIBED upon the ORIGINAL the County Treasurer's tax certificate required by law. Also a certificate of approval of the city or village council, or township board, as the location of lands platted may require.

12. For the purpose of approval and recording, an exact copy is to be made from the ORIGINAL after certificates above referred to are INSCRIBED thereon, and said ORIGINAL and COPY forwarded to the Auditor General of the State for approval and record, together with \$4.00 fee required by the statute. When the ORIGINAL plat has been approved by the Auditor General the same will be forwarded from the Auditor General's Department to the Register of Deeds of the county in which lands are platted, for recording, together with fee required by statute, while the COPY will be filed in the office of the Auditor General. Should proprietor wish to retain a COPY, two copies of the ORIGINAL should be forwarded at the time of forwarding the ORIGINAL plat, one copy of which may be made on tracing linen, if so desired, which second copy will be returned to proprietor with proper certificates thereon.

13. The fee of \$4.00 to accompany the original plat, as above required, covers a fee of \$1.00 to the Register of Deeds for recording, and a fee of \$3.00 to the Auditor General for the benefit of the State.

14. The foregoing is not intended to be a perfect manual containing all that is embodied in the law, but to call attention to points in which plats are most likely to be defective.

15. Every plat sent to the Auditor General, either for approval or for filing in his office, should be accompanied by the name and postoffice address of the person sending it, to insure proper return.

16. The law of 1887 as amended by Act 114 of P. A., 1909, is appended for convenient reference; IT SHOULD BE CAREFULLY STUDIED AND ALL ITS REQUIREMENTS OBSERVED.

17. Observe the requirements of Section 135, General Tax Law of 1893, as amended by Act 154 of P. A. 1895, which is hereto appended.

18. In response to frequent requests for forms of Dedication, Description and Surveyor's Certificate to be observed in making plats, the following has been prepared. While they are short and simple, it is believed they meet the requirements of law.





The attorney general advises that if the proprietor is a widower or bachelor the fact should be stated in the dedication to account for the absence of signature of the wife.

DEDICATION.

KNOW ALL MEN BY THESE PRESENTS, That we..... as proprietor, and..... his wife, have caused the land embraced in the annexed plat to be surveyed, laid out and platted, to be known as..... and that the streets and alleys as shown on said plat are hereby dedicated to the use of the public. (Insert title of plat)

SIGNED AND SEALED IN PRESENCE OF

..... [L. S.]
STATE OF MICHIGAN }
County of..... } ss. .... [L. S.]

On this..... day of..... 19... before me, a Notary Public in and for said county, personally came the above name..... and..... his wife, known to me to be the persons who executed the above dedication, and acknowledged the same to be their free act and deed.

My Commission expires..... Notary public..... Co., Mich.

DESCRIPTION OF LAND PLATTED

The land embraced in the annexed plat of..... is described as follows:
.....

SURVEYORS CERTIFICATE.

I hereby certify that the plat hereon delineated is a correct one, and that permanent monuments, consisting of..... have been planted at points marked (Clearly describe the monuments.) thus..... as thereon shown at all angles in the boundaries of the land platted, and at all intersections of streets or streets and alleys. (Using some symbol such as a small circle (o) or cross (x) or letters or numbers to indicate the exact location.)

NOTE: THE MONUMENTS MUST NOT BE OF WOOD. Surveyor.





## COUNTY TREASURER'S CERTIFICATE RELATING TO TAXES.

Section 135 of Act 154 of the Laws of 1895 requires that when any deed, land contract, plat of any town site, village, or addition to any town site, village plat or city, is presented to the register of deeds for record of filing in his office, he shall require to be furnished at the same time a certificate from the county treasurer that there ARE NO TAXES unpaid on the land covered by the plat and no Tax Liens against it.

You will see that such tax certificate, in the county treasurer's usual form for deeds and other instruments, is stamped, or inscribed upon the ORIGINAL plat before copies are made thereof and before forwarding to the Auditor General.

## SUGGESTIONS TO BE CLOSELY OBSERVED.

1. The term "as proprietor" or "proprietors" should appear after the name, or names of the owners, in the dedication.
2. Do not use rubber stamp for signatures.
3. All names in the body of dedication, acknowledgment and certificates should agree to the letter with signatures, as appended. A full name should not be used in one place and an abbreviation or initial substituted for it in another.
4. If the plat is made by a corporation, the corporate name should be used, followed by the names of its president and secretary and have impressed the seal of the corporation; if by an association, then president and secretary should sign with scroll seals after their signatures.
5. Building restrictions, franchise rights, and the like, have no place in the dedication. It is held that no "reversions" can be reserved in streets and other parcels dedicated to the public, even though an attempt is made to do so in the dedication.
6. It is desirable that the trustee should state his authority; similarly for an attorney-in-fact.

7. The caption should agree exactly with the title as printed in certificates. Correct spelling is very desirable in caption and title.

8. The law requires that in the drawing and in writing there shall be provided two separate, complete and independent descriptions of the land platted, which must be consistent with each other. This means that many items must be repeated, and of course it requires exact agreement in all cases where two recorded items signify the same thing. If the boundaries are described by bearings and distances, the "place of beginning" must be noted on the drawing and the bearings and distances noted on the drawing must agree exactly with those given in the written description.

9. The numbering of lots and blocks in every plat must be regular and continuous commencing with lot 1, block 1, dividing into blocks may be omitted (but not preferable).

10. Distinguish old survey lines, old lot and block numbers, preferably in ink of some other color than black.

11. Numerical dimensions should agree fairly well with scaled values. The length recorded on any boundary line should agree exactly with the aggregate of lot and street dimensions along that line.

12. The boundary of the platted portion should be represented by a continuous line, dotted if desired where it crosses streets.

13. Curved boundaries should be adequately surveyed and their curve elements recorded on the drawing.

14. A lot cannot be divided by road or another lot.

15. Fully describe all "excepted" parcels.

16. All alleys, public walks and the like should be plainly designated as such.

17. The law requires that the plat be made by a competent person. This implies a workmanlike execution of the plat in every detail. Freehand linear drawing should not be attempted, nor should other principles of good surveying and draftsmanship be offended.

18. No plat will be examined at this Department that does not contain all certificates required by the statute.

19. No plat should be forwarded to this department for ex-

amination without the name and address of proprietor or surveyor or accompanying the same.

20. No plat will be examined or considered until statutory fee of \$4.00 is received.

21. The examination of a plat by the Auditor General's Department does not presume to discover all mathematical errors, nor even to provide suggestions for remodeling the descriptive matter. All who submit plats should, at least, carefully review them when returned for correction. Sometimes errors are carelessly introduced in the very act of correction. If a similar error appears a number of times on the same plat only one mention may be made of its occurrence; but the sender of the plat should make sure that the correction is made wherever necessary.

22. Following the law are resolutions adopted by the Michigan Engineering Society at their annual meeting held at Ann Arbor in January, 1886, which are worthy of attention as expressing the views of the association composed of the most intelligent and competent surveyors of the State.

23. No plat can be approved that includes a replat of a part or of the whole of a former plat and land not previously platted. In such cases, the previous plat or that portion included in the new plat must first be vacated.

SECTION 3372 AS AMENDED BY ACT 114 OF THE PUBLIC ACTS OF 1909, AND SECTIONS 3373-3957, COMPILED LAWS OF 1897.

SECTION 1. Whenever any town, township or subdivision thereof, city, village or addition thereto shall be laid out or shall be altered or vacated as hereinafter provided, within this State, the proprietor or proprietors thereof shall cause a survey and a true map or plat thereof to be made by a civil engineer, surveyor or other competent person. Such map or plat shall in every case be made on a scale showing not more than two hundred feet to an inch, on sheets of good muslin-backed paper, eighteen inches by twenty-four inches in size, and more than one plat shall not be made on one sheet. There shall be written or printed upon the

paper on which said map or plat shall be made a full and detailed description of the land embraced in said map or plat, showing the township and range in which such land is situated and the sections and parts of sections platted, and containing the name of the town, city, village or addition platted, the name or names of the proprietor or proprietors thereof, and of the engineer, surveyor or person making said map or plat, with the date. The same shall be signed by such proprietor or proprietors and their wives, and engineer, surveyor or person making the same, and shall be witnessed and acknowledged by the owners, as deeds conveying lands are required to be witnessed and acknowledged. The sections and parts of sections platted shall also be designated by lines drawn upon such map or plat, with appropriate letters and figures, and in case of a subdivision of lots or blocks of a previous survey, the outlines of the original or previous lots or blocks so subdivided shall be designated by lines drawn upon said map or plat, and shall be marked with appropriate letters and figures. There shall also be on such map or plat a plain designation of the cardinal points and a correct scale. Before such map or plat shall be approved by the Auditor General and before such map or plat shall be recorded by the register of deeds, the proprietor or proprietors thereof shall cause to be attached to said map or plat a certificate from the county treasurer whether there are any tax liens or titles held by the State or by any individual against such piece or description of land described in such map or plat, and whether all taxes due thereon have been paid for the five years preceding the date of such certificate, and in the absence of such certificate the Auditor General shall not approve said map or plat until such certificate is secured and presented; and before such map or plat shall be approved by the Auditor General, and before such map or plat shall be recorded by the register of deeds, the proprietor or proprietors thereof shall cause to be attached to said map or plat a certificate of approval from the township board, or the city council, or the village council having jurisdiction over the lands so described in the said map or plat. For the purpose of such approval by the Auditor General and recording with the register of deeds, the proprietor or proprietors shall cause to be made by a civil engineer, surveyor or other competent person, on

the same scale and on paper of the same size and quality as that on which the map or plat is required to be made, an exact copy of said map or plat with detailed description or descriptions, signatures, witnesses, acknowledgment and certificate of county treasurer; and it shall be the duty of the proprietor or proprietors to cause said map or plat to be forwarded to the Auditor General for his approval, together with said copy thereof, and to deposit with the Auditor General a fee of four dollars for approving, filing and recording said map or plat. It shall be the duty of the Auditor General of the State to approve said map or plat when same shall conform in his opinion to the requirements of this act, and pay over three dollars of said sum to the State Treasurer to be credited to the general fund and to forward the remaining sum of one dollar to the register of deeds as the registration fee as hereinafter provided. In case such map or plat is approved by the Auditor General of the State, he shall immediately forward said map or plat, approved, with certificate and date of approval inscribed thereon to the register of deeds in the proper county, and shall pay over to said register of deeds the one dollar fee herein provided for at such time when said register of deeds shall have furnished the Auditor General of the State a proper certificate of recording said map or plat. In case said map or plat is not approved by the Auditor General the sum of one dollar herein specified as registration fee shall be returned to the proprietor or proprietors of said map or plat; but in no case shall the three dollars which has been turned into the State treasury and credited to the general fund be returned. If for any reason the Auditor General of the State does not approve the said map or plat, he shall notify the proprietor or proprietors and give his reason therefore. It shall be the duty of the Auditor General of the State to compare the copy of said map or plat with the map or plat, and transcribe on said copy a certificate of the recording of said map or plat forwarded by the register of deeds in the county where said map or plat is recorded, and inscribe on said copy of said map or plat a certificate of the Auditor General of the State, giving the date of filing of said copy and that the same is a true copy of the said map or plat forwarded to the register of deeds

for recording: *Provided*, That in case the said proprietor or proprietors of said map or plat desire to retain a copy of said map or plat, the said proprietor or proprietors shall forward a second exact copy of said map or plat upon paper of the same kind and quality or upon tracing linen, and otherwise in all respects as heretofore provided for the forwarding of the first copy of said map or plat, to the Auditor General who shall return the same to said proprietor or proprietors without additional cost, with a certificate inscribed thereon that the said copy is a true and exact copy of the said map or plat forwarded to the register of deeds for record, and that there is also a true copy of said map or plat on file in the office of the Auditor General of the State as provided by this act: *Provided further*, That all plats hereafter made in this State including plats of land owned or controlled by summer resort associations, and all other plats made by any other person, association or corporation shall be approved, filed and recorded in the manner provided in this section. The Auditor General shall keep an index in which he shall enter alphabetically the name of every town, city, village and addition, a copy of record of the map or plat of which shall be filed in his office, the date of filing the same, and whatever else he may think necessary to facilitate reference thereto. The said register, upon receipt of said map or plat from the Auditor General of the State, shall fasten the said map or plat in a book of the proper size for such paper so that it shall not be folded, which book shall be strongly bound in leather and provided at the expense of the said county, and such copy so fastened in said book shall be held and taken to be a record of the said map or plat, with like effect as if the said map or plat had been actually transcribed by said register in a book in his office, and for any wilful violation of this provision by a register of deeds he shall be liable to a penalty of ten dollars, and shall also be liable to pay all damages which any person may sustain by reason thereof, to be recovered in an action of trespass on the case. The register shall certify on such map or plat the time when it was recorded as aforesaid with a reference to the book or page where recorded. He shall note on the record the time when made, and shall keep a separate index of maps or plats, in which he shall enter alphabetically the name of every



town, city, village or addition, the map or plat of which shall be recorded by him, with a reference to the book and page where the same shall be recorded. The register of deeds, after recording said map or plat as herein provided, and before he shall be entitled to the one dollar registration fee to be forwarded by the Auditor General of the State as herein provided, shall cause to be furnished the Auditor General of the State a proper certificate of the recording of said map or plat upon such blank form which may be forwarded by the Auditor General of the State. The map or plat, with the certificate of record endorsed thereon, the record thereof made as aforesaid, or a properly certified transcript of such record, shall be received in all courts in this State as *prima facie* evidence of the making and recording of such map or plat in conformity with the provisions of this act, and the copy of such recorded map or plat filed or in the Auditor General's office, or a properly certified transcript thereof, shall be received in all courts of the State as *prima facie* evidence of the above matters, and also the filing of said copy in the Auditor General's office. If any person or persons shall sell and convey any lot or lots within any such town, city, village or addition, by reference to such plat before the map or plat thereof shall be recorded and the copy of the record thereof filed as aforesaid, he or they shall forfeit and pay the sum of ten dollars for each lot so sold. For all services by this act required to be performed by a register of deeds in respect to any such map or plat brought into his office for record, the said register shall be entitled to receive the sum of one dollar, which shall be paid as herein provided: *Provided*, That in all cases where the proprietor or proprietors of any piece or pieces of land shall have caused the same to be laid out and platted as a city, town or village, or as an addition to a city, town or village or where the proprietors have caused such city, town or village lots to be deeded by metes and bounds and courses and have failed or neglected to have a plat thereof made and recorded as provided by this act, the supervisor or assessor of the township, city or village in which such land is situated shall, when authorized by the township board of such township or by the common council or the board of trustees of such city or village, cause a map or plat of said city, town village or addition to be made

under his hand and seal, properly acknowledged by him and in every way following the provisions of this act, except as to the certificate of the county treasurer relating to tax titles and tax liens as provided by this act, and showing by reference to this act the authority for the same. Such plat or map, when recorded and filed as herein provided by this act, shall be treated in respect to the assessment, collection and return of taxes and the sale of said lands for delinquent taxes, as if the same had been made by the proprietor or proprietors: *Provided*, That such proceedings shall not interfere with vested rights: *Provided further*, That the expense of making said plat or map, when done by the supervisor or assessor according to the provisions of this act, shall be paid by the township, city or village in which such plat is located.

SECTION 3373. That such maps or plats as are by this act required to be recorded shall particularly set forth and describe such portion of the government survey as is intended to be platted, and when said premises are not included in the legal subdivisions of the government surveys then the boundaries to be defined by metes and bounds and courses. Said maps or plats shall also particularly set forth and describe all the public grounds, except for streets and alleys by their boundaries courses, and extent and all streets and alleys by their courses, lengths, widths, names or numbers, by writing or figures upon that portion of the map or plat intended for those uses. And all the lots intended for sale may be numbered, either by progressive numbers, or, if in blocks, progressively numbered in each block, and the blocks progressively numbered or lettered. Where all the lots of any block are of the same dimensions it shall be sufficient to mark the precise length and width upon one tier thereof; but all gores, triangles, or other lots which are not either squares or parallelograms, shall have the length of their sides plainly defined by figures.

Permanent monuments shall be located in the ground at all angles in the boundaries of the land platted, and at all the intersections of streets, or streets and alleys, as shown on the map or plat, and when there are permanent objects in the vicinity of such monuments the bearings and distances of such objects shall be noted. The character of the monuments and the bearings and



distances of such witness points or objects shall be distinctly given in the most convenient manner on the plat. The surveyor or engineer making such plat shall certify that the plat is a correct one, and that the monuments described in it have been planted as therein described. The map so made and recorded in compliance with the provisions of this act shall be deemed a sufficient conveyance to vest the fee of such parcels of land as may be herein designated for public uses in the city or village within the incorporate limits of which the land platted is included, or if not included within the limits of any incorporated city or village, then in the township within the limits of which it is included in trust to and for the uses and purposes therein designated, and for no other use or purpose whatever.

SECTION 3957. When any deed, land contract, plat of any town site, village, or addition to any town site, village plat or city, or any other instrument for the conveyance of title to any real estate, is presented to the register of deeds of any county in this State for record or filing in his office, he shall require from the person presenting the same a certificate from the Auditor General, or from the county treasurer of the county, whether there are any tax liens or titles held by the State, or by any individual, against such piece or description of land sought to be conveyed by such instrument, and that all taxes due thereon have been paid for the five years preceding to the date of such instrument, and in default of the presentation of such certificate he shall not record the same until such certificate is secured and presented. The register of deeds shall note the fact upon said deed that said certificate has or has not been presented to him when such instrument is presented for record, and in case the person presenting such instrument shall refuse to procure such certificate, he shall endorse that fact upon said instrument, over his official signature, and shall refuse to receive and record the same: *Provided*, That the provisions of this section shall not apply to the filing of any town or village plat for the purpose of incorporation, in so far as the land embraced therein is included in a plat already filed in the office of the register of deeds, or in so far as the description of lands therein is not changed by such plat, nor to the filing of any copy of the town, village or city

plat in case the original plat filed in the office of such register of deeds has been lost or destroyed, nor to any sheriff's or commissioner's deed executed for the sale of lands under any proceeding in law, or by virtue of any decree of any of the courts of this State, nor to any deed of trust by any assignee, executor or corporation executed pursuant to any law of this State; nor to any quit claim deed or other conveyance containing no covenants of warranty; nor to any land patent executed by the President of the United States, or the Governor of this State, nor to any tax deed made by the Auditor General; nor to any deed executed by any railroad company conveying its right of way, provided such deed is accompanied by a certificate of the Auditor General showing that all specific taxes due from said railroad company have been paid, to and including the year in which such deed is executed. A violation of the provisions of this section by any register of deeds shall be deemed a misdemeanor, and upon conviction thereof he shall be fined not to exceed one hundred dollars, and he shall further be liable to the grantee of any instrument so recorded for the amount of damages sustained, to be recovered in an action for debt in any court of this State.

## RESOLUTIONS OF THE MICHIGAN ENGINEERING SOCIETY.

Recommending the following points in connection with and supplementary to the instructions contained in the circular from the Auditor General's office of May 29, 1885:

*First*, That the written description of the land platted should be clear and distinct, describing it in as brief a manner as is consistent with accuracy, so that there shall be no misunderstanding as to what land the plat is intended to cover; that the outlines of the plat itself shall be marked with appropriate letters and figures corresponding with the written description indicating the courses and length of those lines; that if any lots lying within the outlines of the plat are not intended to be considered a part of the plat they should not be numbered or lettered, and the fact that they

are excepted be noted in the written description. The courses and length of the lines of such lots should be marked on the plat by appropriate letters and figures, and the lots themselves marked on the plat as accepted.

*Second,* Use a short and simple form of acknowledgment. \* \* \*

*Third,* Use but one unit of measurement in the plat. Make a diagram on the plat of the scale used, with appropriate letters to show what the scale is.

*Fourth,* The four cardinal points be indicated in a simple manner by an arrow or *fleur de lis*, with appropriate letters. This we understand to be intended merely to indicate in a general way the points of compass on the map. Whenever practicable, give the courses in the written description and on the plat from the true meridian, and also, when practicable, that the angle of intersecting lines be given on the plat.

*Fifth,* That it should be remembered that Sec. 3373 is to be considered in connection with the fifth clause of Sec. 3374.

*Sixth,* That we esteem it of the first importance that permanent monuments be located in the ground at all important points in the plats, and the character and location of such monuments, by their bearing trees or points, be distinctly given on the plat.

## REFERENCES.

- Gillespie's Surveying, 1851 to date. Revised by Cady Staley 1887.  
Published by D. Appleton & Co. New York, N. Y.
- Surveying. Daniel Carhart, C.E. Western University of Pennsylvania. 1887.  
Published by Ginn & Co. Boston, Mass.
- Theory and Practice of Surveying. J. B. Johnson, C.E. Washington University, St. Louis, Mo. 1886 to date. Chapter on Geodesy.  
Published by John Wiley & Sons. New York, N. Y.
- Plane Surveying. Wm. G. Raymond, C.E. 1896.  
Published by American Book Co.
- Field Engineering. Wm. H. Searles, C.E. Railroads. Pocket-book. Excellent tables.  
Published by John Wiley & Sons. New York, N. Y.
- Topographic Surveying. Herbert M. Wilson, C.E. 1900 to date. Part V, Geodesy. Chapter XLI, Camera Surveying.  
Published by John Wiley & Sons. New York, N. Y.
- Plane Surveying. P. C. Nugent, C.E. Syracuse University, 1902.  
Published by John Wiley & Sons. New York, N. Y.
- Surveying. Breed & Hosmer. 1907.  
Published by John Wiley & Sons. New York, N. Y.
- Advanced Surveying. Breed & Hosmer. 1908.  
Published by John Wiley & Sons. New York, N. Y.
- Plane Surveying. J. C. Tracy, C.E. 1908. Pocket Manual.  
Published by John Wiley & Sons. New York, N. Y.

- Manual of Land Surveying. F. Hodgman. Pocket book. Legal subjects.  
Published by the author, Climax, Mich.
- Manual of U. S. Land Survey. Instructions for original surveys.  
Published by General Land Office, Washington, D. C.
- Photographic Surveying. E. Deville, Surveyor General of Canada, 1889 to date.  
To be obtained of the Superintendent of Stationery, Department of Public Printing and Stationery, Ottawa, Canada.
- Photographic Instruments and Methods. J. A. Flemer. 1906.  
Published by John Wiley & Sons. New York, N. Y.
- Law of Operations Preliminary to Construction. John Cassan Wait. Very useful to surveyors and engineers.  
Published by John Wiley & Sons. New York, N. Y.

## DO ANY OF THESE THINGS FIT YOU?

**Stop!**

Going out to work without a note book and pencil.

**Stop!**

Going out to work without all the information to be had.

**Stop!**

Taking instruments out to work without first knowing their condition.

**Stop!**

Taking instruments out to work without all necessary accessories,—as tripod, plumb bob, reading glass, shade, or adjusting pin.

**Stop!**

Sighting at the top of a line staff, or station pole.

**Stop!**

Plumbing up with a line staff. Use a plumb bob and line.

**Stop!**

Using splinters, and twigs, to mark stations with. Use stakes, or plugs.

**Stop!**

Using stakes for plugs. Use plugs, four inches, or more, across, driven flush with the ground.

**Stop!**

Pulling up plugs till through with them.

**Stop!**

Leaving any stakes, plugs, or other marks, temporarily in use while making a survey, to be mistaken for the real marks the survey was made to obtain, or perpetuate. Knock out every thing else,—but not till done with them.

**Stop!**

Removing land marks, to plant others, except in the presence of witnesses, and with a complete record of every one present, and every thing found, done, and planted.

**Stop!**

Being so particular to read the leveling rod to thousandths where it is not needed, while misreading the tenths and feet. The thousandths do not really amount to so very much when the feet, or tenths, or both, are read wrong.

**Stop!**

Making hasty jots and calling it a record. Make a record to be read, understood, and not mistaken, by a stranger. Do it when the work recorded is done,—not leave it to be guessed at afterwards.

**Stop!**

Making scattered, confused, or mixed up notes. Use a form, or write in full.

**Stop!**

Using an instrument the instant any of its parts work hard. Find out what the matter is and fix it, or have it fixed.

**Stop!**

Leaving things around on the work, and forgetting them. This delays not only the careless person who forgets, but others,—perhaps stopping the whole work.

**Stop!**

Leaving things around at all,—to be picked up afterwards.

**Stop!**

Putting things away in any kind of disorder.

**Stop!**

Putting instruments, or tools, of any kind, away, unfit for immediate use.

**Stop!**

Depending on others to make good any careless practices.  
Strive to do things as well as they can be done.

**Stop!**

Doing things "Good enough." Do them so no man can better them.

**Stop!**

Trying to work without judgment,—endeavoring to mechanically follow a process. Strive to become able to make such things as processes. Processes, methods, learning, attainments, are properly tools, or servants,—not masters.

**Stop!**

Being satisfied with the attainments acquired in any direction. What has been accomplished is but a step stone to something more, or better.



## EXAMINATIONS.

Outfit.

To write with ink.

Triangles.

Scale.

Pencil dividers.

Pencil eraser.

Pencil,—No. 3.

Write all of the subjects for examination, with their numbers, on the first leaf of the blue book.

Write with ink. Write plain,—or print.

Use well drawn diagrams.

No reports of examinations given out.

## CONDITIONED STUDENTS.

To continue their work until able to write correctly on all of the subjects in the following list:

Measuring with steel tapes.

Reading an angle.

Intersections and corrections.

Passing obstructions.

Circular curves.

Traversing.

Setting up a transit and a level.

Peg levels.

Verniers.

    Least reading.

    Reading a vernier.

Profile leveling.

Running a straight line.

Adjusting instruments.

Town, city, and village plats.





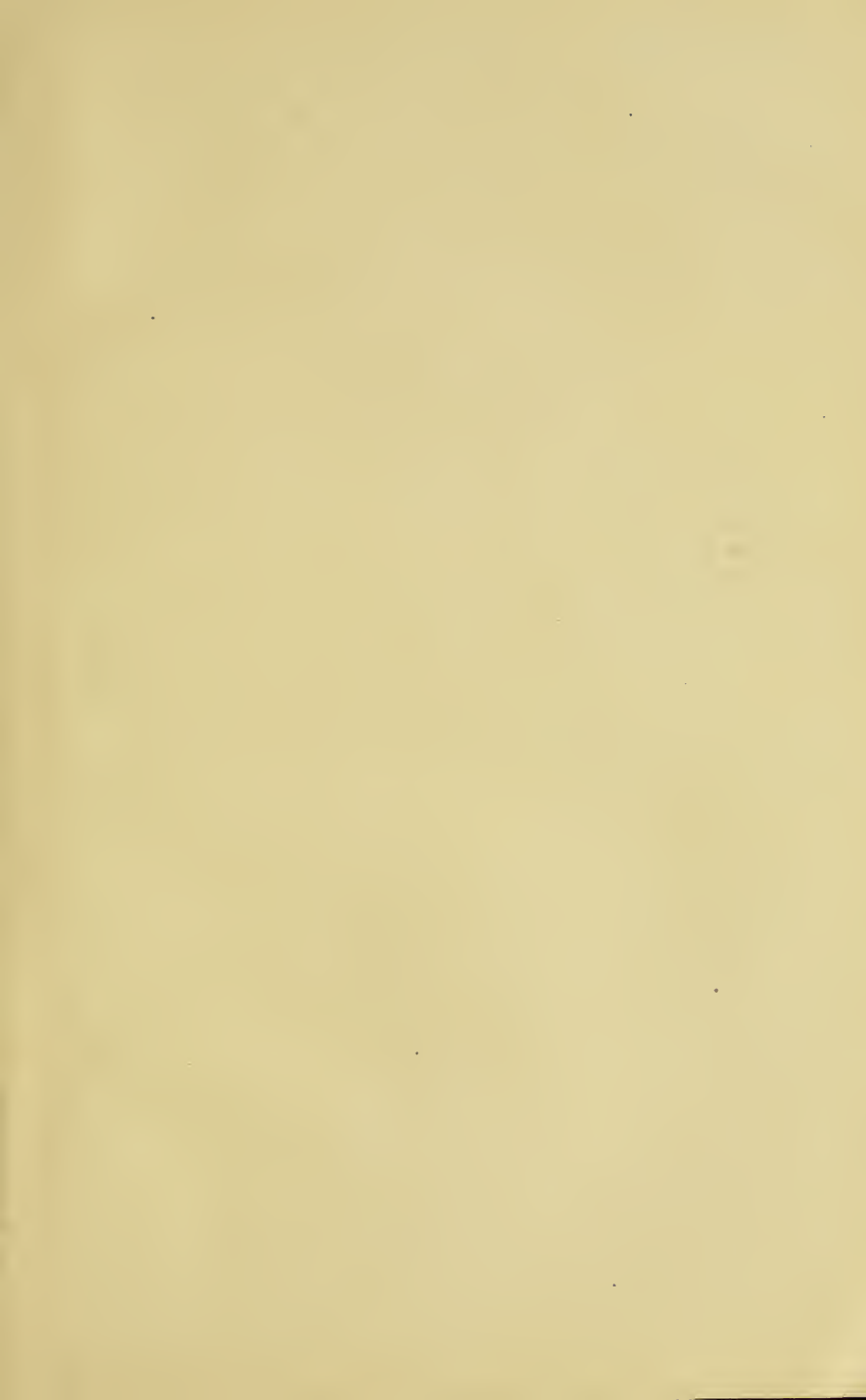

NOV 3 1911









LIBRARY OF CONGRESS



0 020 365 748 1