

# HARVEST<sup>TM</sup> INTERNATIONAL INC

A FRIESEN COMPANY

## **INTRODUCING THE LASERPRO 1: A NEW GENERATION OF ROW UNIT.**

LASER FORGED, HIGH TENSILE STEEL OFFERS A MAXIMUM DURABILITY ROW UNIT FOR PRECISION & HIGH SPEED PLANTING. WHEN IT COMES TO DURABILITY, CONSISTENCY, & SERVICEABILITY, THE LASERPRO 1 IS THE GROUNDBREAKING CONTENDER

## **LASERPRO 1**

\*NARROW & TWIN ROW LPIN MODEL AVAILABLE



Designed for Precision

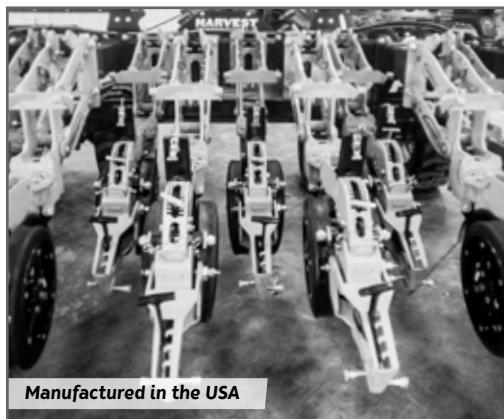

Manufactured in the USA



QuickRelease™ Closing Mount

AMERICAN MANUFACTURED



# LASERPRO 1

PATENT PENDING

## FEATURES

- 1 **TAPERED ULTRADUTY BUSHING ADJUSTMENT**  
*Self lubricating polymer; adjusts in seconds*
- 2 **LASER CUT HIGH-TENSILE STEEL**  
*Unparalleled consistency & durability*
- 3 **PARALLEL LINK BATTLEARMS™**  
*Supported by 1" high yield pivot shaft*
- 4 **BUILT-IN DOWNPRESSURE BRACKETS**  
*DeltaForce & AgLeader down pressure support*
- 5 **BUILT-IN GAUGE WHEEL CAMBER ADJUSTMENT**  
*Quickly adjust wheel angle to remain true to discs*
- 6 **LATERAL GAUGE WHEEL ALIGNMENT**
- 7 **QUICKRELEASE™ CLOSING WHEEL MOUNT**  
*Replace closing wheels (not included) in seconds*
- 8 **LATERAL CLOSING WHEEL ALIGNMENT**
- 9 **POWDERGUARD PLUS™**  
*Superior powdercoat coverage & durability*
- 10 **STANDARD NON-METRIC SERVICE BOLTS**
- 11 **STANDARD GAUGE WHEELS**  
*Narrow spoked MudSmith upgrades available*
- 12 **INDUSTRIAL CHROME SEED TUBE PROTECTOR**
- 13 **MINI-HOPPER SUPPORT OPTION**  
*Seed box brackets & hoppers available*
- 14 **OPTIONAL VAPPLY HD BRACKET**

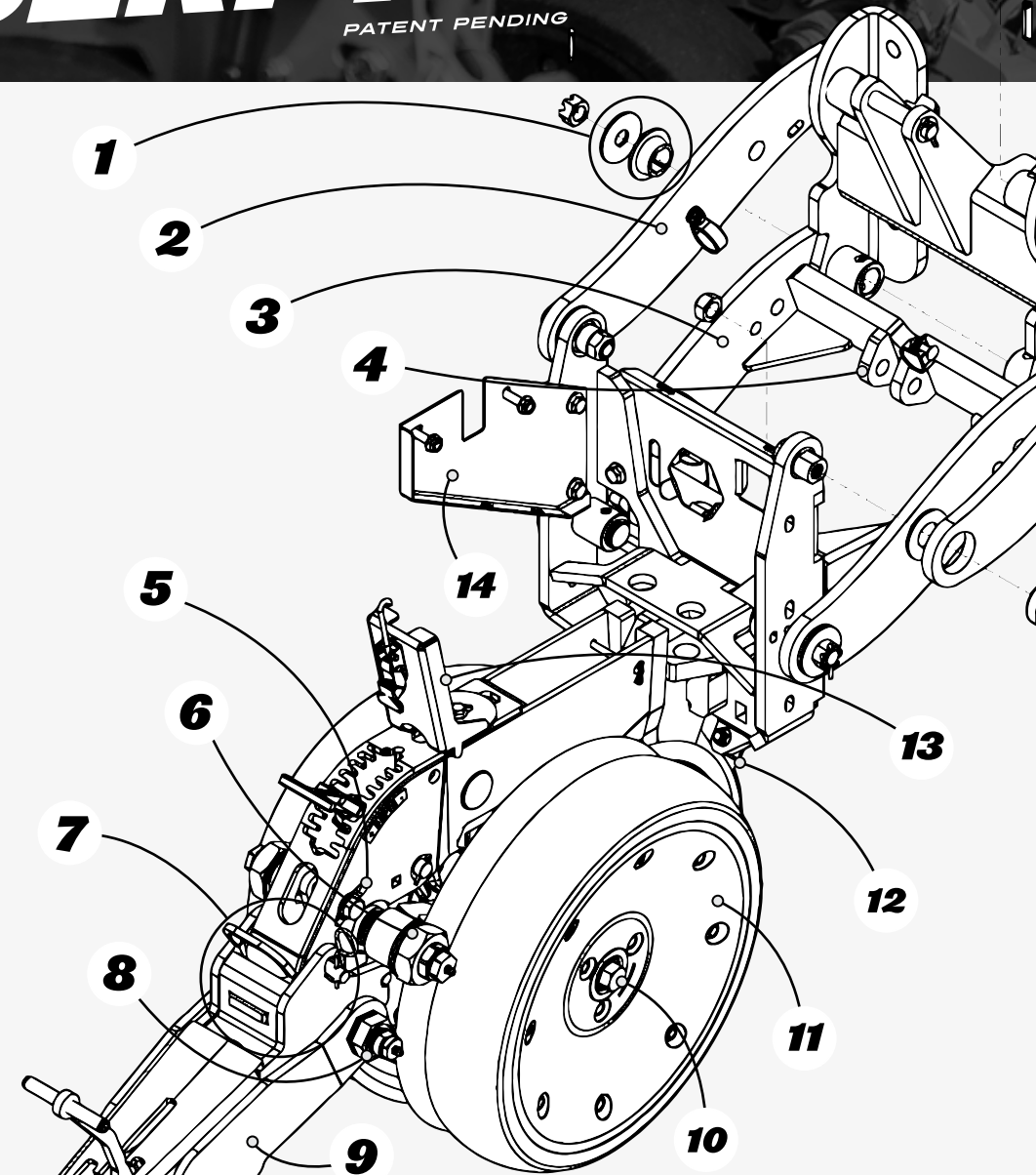

**QUICKRELEASE™ CLOSING WHEEL MOUNT**  
Pull a pin for fast service or swapping mounts w/ different style wheels

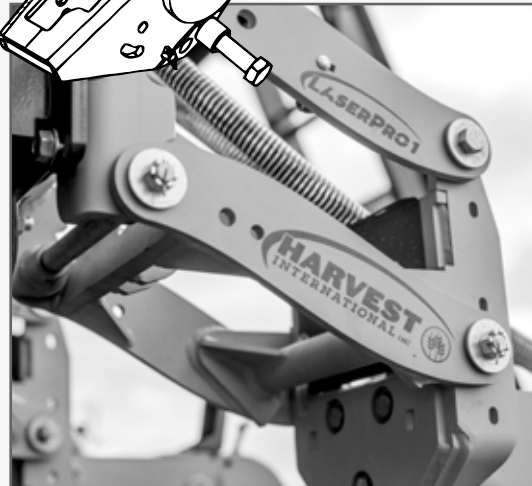

**ULTRADUTY PARALLEL LINK BATTLEARMS™**  
Tapered service-free bushings & solid steel anti-twist shaft.



10" narrow row spacing LASERPRO1N





# ENGINEERED FOR ENDURANCE, READY FOR PRECISION PLANTING

DESIGNED TO INTEGRATE WITH THE LATEST PRECISION SEED METERS & PLANTING TECHNOLOGY

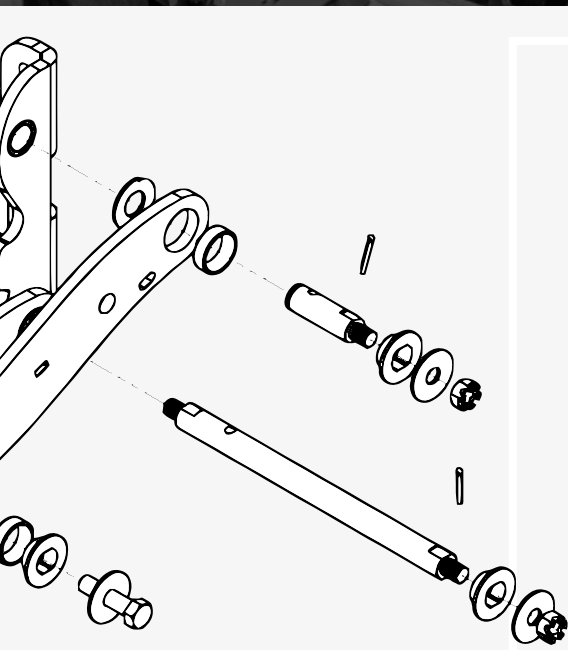

**THE LASERPRO1 ROW UNIT WAS** developed from the ground up as an answer to many of the challenges voiced by progressive growers in a market where precision planting technology outpaced the equipment that moved it through the field. Now the LASERPRO1 is ready to outlast & outperform.

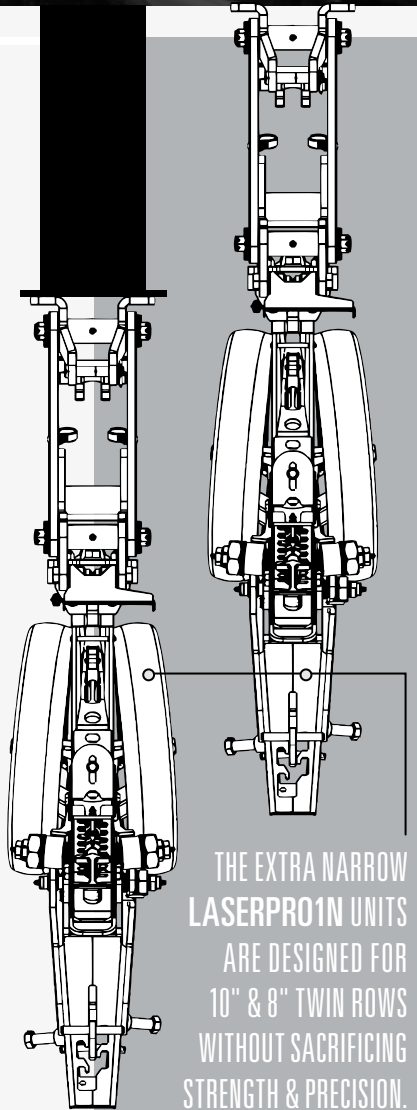

THE EXTRA NARROW LASERPRO1N UNITS ARE DESIGNED FOR 10" & 8" TWIN ROWS WITHOUT SACRIFICING STRENGTH & PRECISION.



**LASERPRO1 w/ vDrive insecticide boxes**  
Integrated with FurrowJet.



**LASERPRO1 w/ 3bu seed boxes**  
Configured on a 20' Harvest International dual frame rigid bar on 15' rows.



PowerPlant Model: RB1010



**Lateral & Built-In Camber Gauge Wheel Adjustment**  
Standard tungsten carbide disc scrapers offer extended wear



**Designed for custom configuration**  
Dealer-installed vSet seed meters, SureDrive, & fertilizer openers.

**"BUILT SO TOUGH, THEY'RE GROUNDBREAKING"**



# ROW SPACING

15"

12" SETBACKS CONFIGURED ON EVERY OTHER ROW.

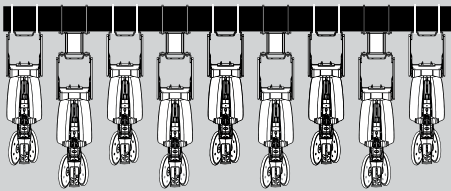

20"

12" SETBACKS CONFIGURED VARIABLY BEHIND WHEEL MOUNTS.

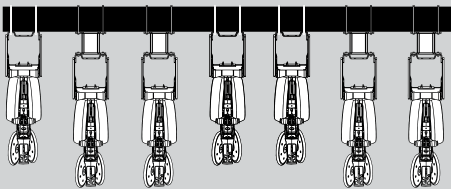

30"

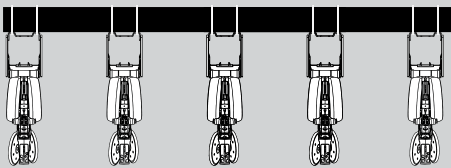

10"

20" NARROW SETBACKS CONFIGURED ON EVERY OTHER NARROW ROW.

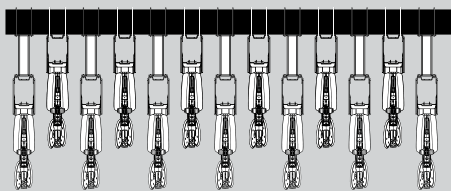

## LASERPRO 1

Can be configured individually on any row spacing 14" & wider. Mini-hoppers or seed boxes.

## LASERPRO 1N

Can be configured individually on any row spacing narrow as 8", ideal for twin row. Mini-hopper only.

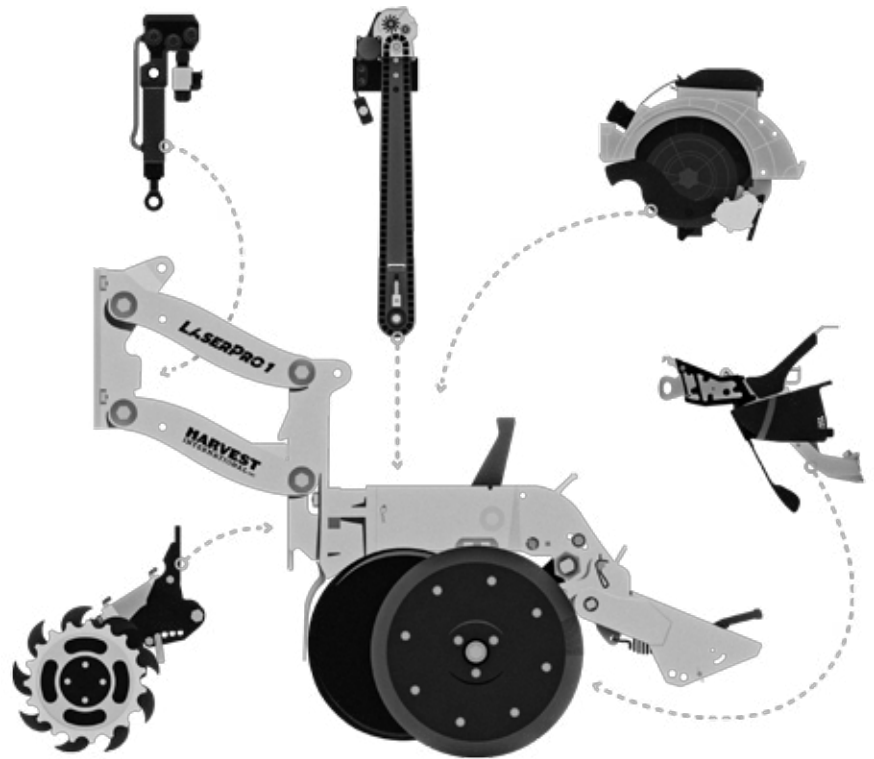

LASERPRO1 ROW UNITS DO NOT INCLUDE, BUT ARE DESIGNED TO FACILITATE\*, DELTAFORCE OR AGLEADER HYDR DOWN PRESSURE, VSET CLASSIC/2/SELECT, 1.6/1.9/3BU SEEDBOXES, FURROWJET, SPEEDTUBE, MULTI-HYBRID, VDRIVE INSECTICIDE, VAPPLY HD, A WIDE VARIETY OF CLOSING WHEEL & ROW CLEANER SYSTEMS, & MORE.

\*NOTE: NOT ALL PRODUCTS WILL WORK TOGETHER ON ALL LASERPRO1 MODELS. LASERPRO1 ROW UNITS ARE NOT DESIGNED FROM THE FACTORY TO FACILITATE ALL 3RD PARTY ROW UNIT ATTACHMENTS. CONSULT WITH YOUR LOCAL DEALER TO FIND A CONFIGURATION THAT WILL WORK FOR YOU.



401 W 20TH STREET · STORM LAKE, IA 50588  
 TEL: 712.213.5100 · TOLL: 888.218.5373 · FAX: 712.213.5109  
 WWW.HARVEST-INTERNATIONAL.COM

MADE  
 IN THE  
 USA

