

HARVEST™ INTERNATIONAL INC

A FRIESEN COMPANY

INTRODUCING THE **ULTRALIFT**: THE FUTURE OF STACK FOLD PLANTING

INNOVATIVE DESIGN FEATURES UNDER-BAR **ULTRALIFT™** CYLINDER, CAPABLE OF INDUSTRY LEADING 18° UPWARD FLEX, BULK FILL OR SEED BOX ON NARROW, WIDE, & TWIN ROW SPACINGS, READY FOR PRECISION & HIGH SPEED PLANTING.

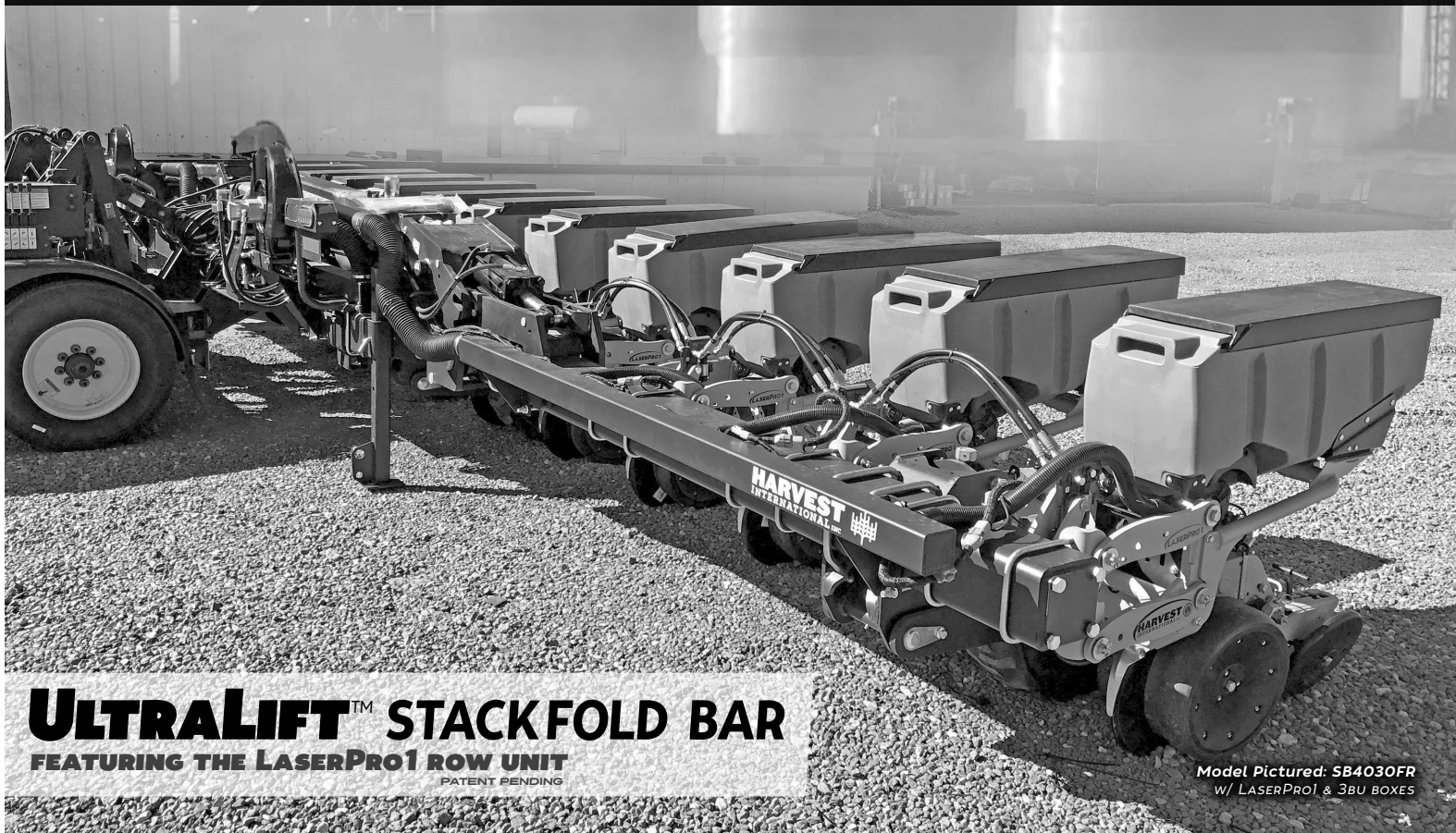

ULTRALIFT™ STACK FOLD BAR

FEATURING THE **LASERPRO1** ROW UNIT
PATENT PENDING

Model Pictured: SB4030FR
w/ LASERPRO1 & 3BU BOXES



CONFIGURABLE ROW SPACING



CENTER MOUNTED BULK FILL SYSTEM

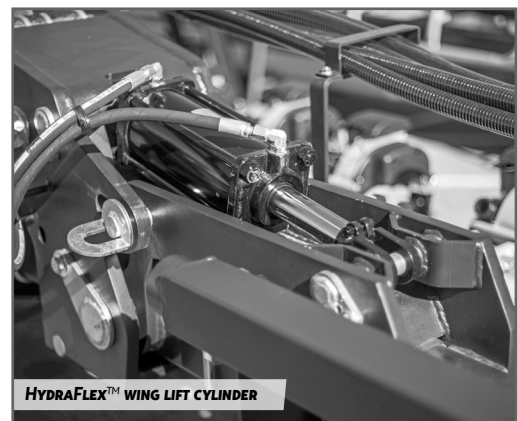

HYDRAFLEX™ WING LIFT CYLINDER

ULTRALIFT STACKFOLD PLANTER

PATENT PENDING

A NEW GENERATION STACK FOLD TOOLBAR, INNOVATED FOR PRECISION AG, ENGINEERED FOR MODERN PLANTING CHALLENGES

SPECIFICATIONS

15" | 20" | 30" | 36" | 38" ACHIEVABLE ROW WIDTHS

TWIN ROW

SB30' - SB40' MODELS

STANDARD 3PT HITCH
 INTEGRATED VACUUM PORT TUBE
 MERCURY ON/OFF SWITCH
 ROAD SAFETY LIGHTS

45 UNIT SINGLE TANK CSD
 OPTIONAL GAUGE OR LIFT ASSIST WHEELS
 HYDRAFlex™ WING CYLINDER

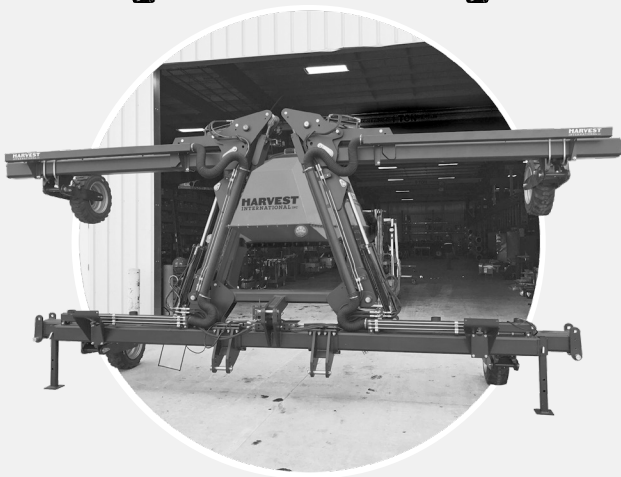
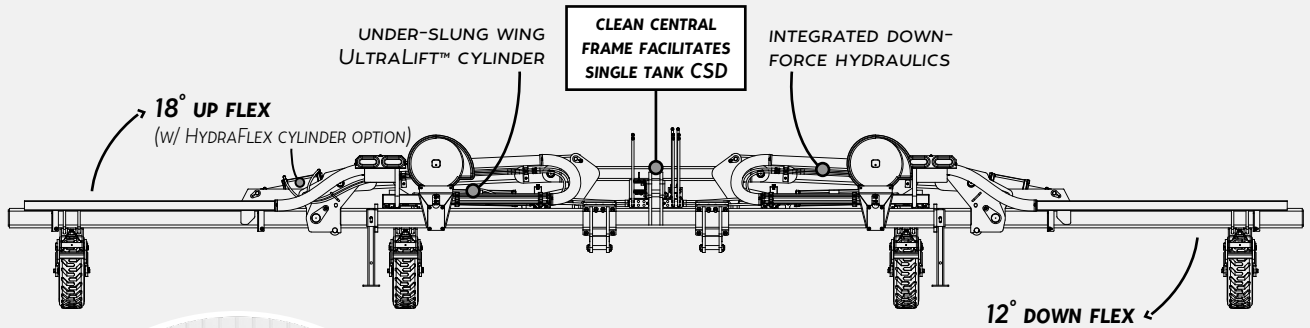

SB4036-TR ULTRALIFT™
 36" TWIN ROW LASERPROIN-TR W/ 1.2BU HOPPERS

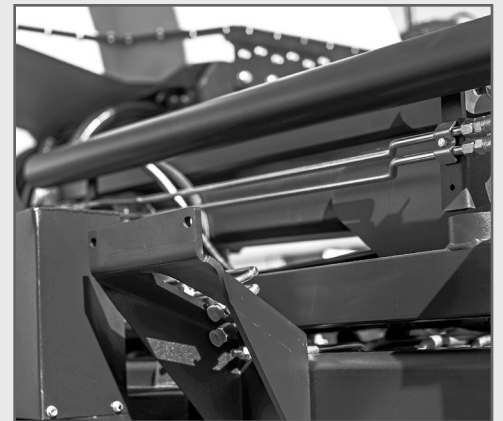
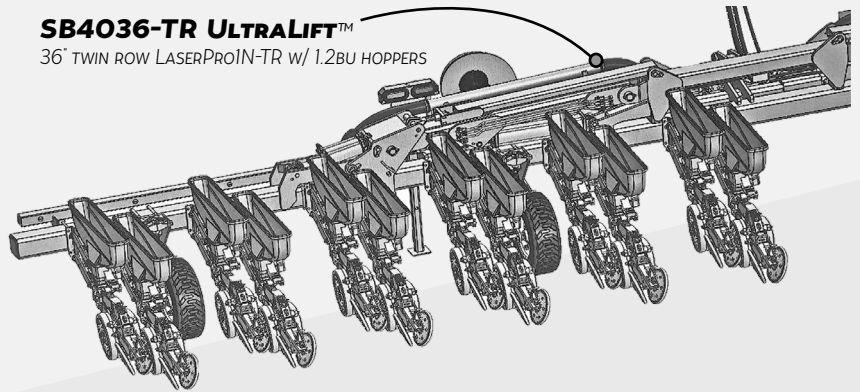

H HARVEST INTERNATIONAL INC

401 W 20TH STREET · STORM LAKE, IA 50588
 TEL: 712.213.5100 · TOLL: 888.218.5373 · FAX: 712.213.5109
www.harvest-international.com

MADE IN THE USA