

General Description

The ICU3 instrument cluster is comprised of gauges, warning lights, indicator lights, a buzzer, and a driver display screen built into a single unit to provide the driver with engine and vehicle information. The ICU3 receives data through datalink messages, hardware inputs, and air pressure inputs. The ICU3 contains up to eight individual gauges, and up to six additional satellite gauges. See Fig. 1. The ICU3 contains a message center with a liquid crystal display (LCD), driver display, and up to 28 warning and indicator lamps. The ICU3 has no field changeable parameters, with the exception of those functions that can be set using the Mode/Reset button, and the display menus such as service intervals and odometer units.

Main ICU Gauges

The speedometer, fuel level, engine coolant temperature, tachometer, primary and secondary air pressure, and engine oil pressure gauges are standard on all ICU3 configurations. Vehicles may have additional optional gauges depending on the configuration. The ICU3 receives data to drive most of the gauges from either J1587 datalink messages on vehicles built with EPA07 emissions and prior, and over J1939 on EPA10 and later vehicles. Data is received from the engine controller or transmission controller, or from sensors wired directly to the ICU3. Air pressure gauges are connected directly to the air system they monitor. They are not controlled by the ICU directly, except for backlighting. The ICU3 gauges

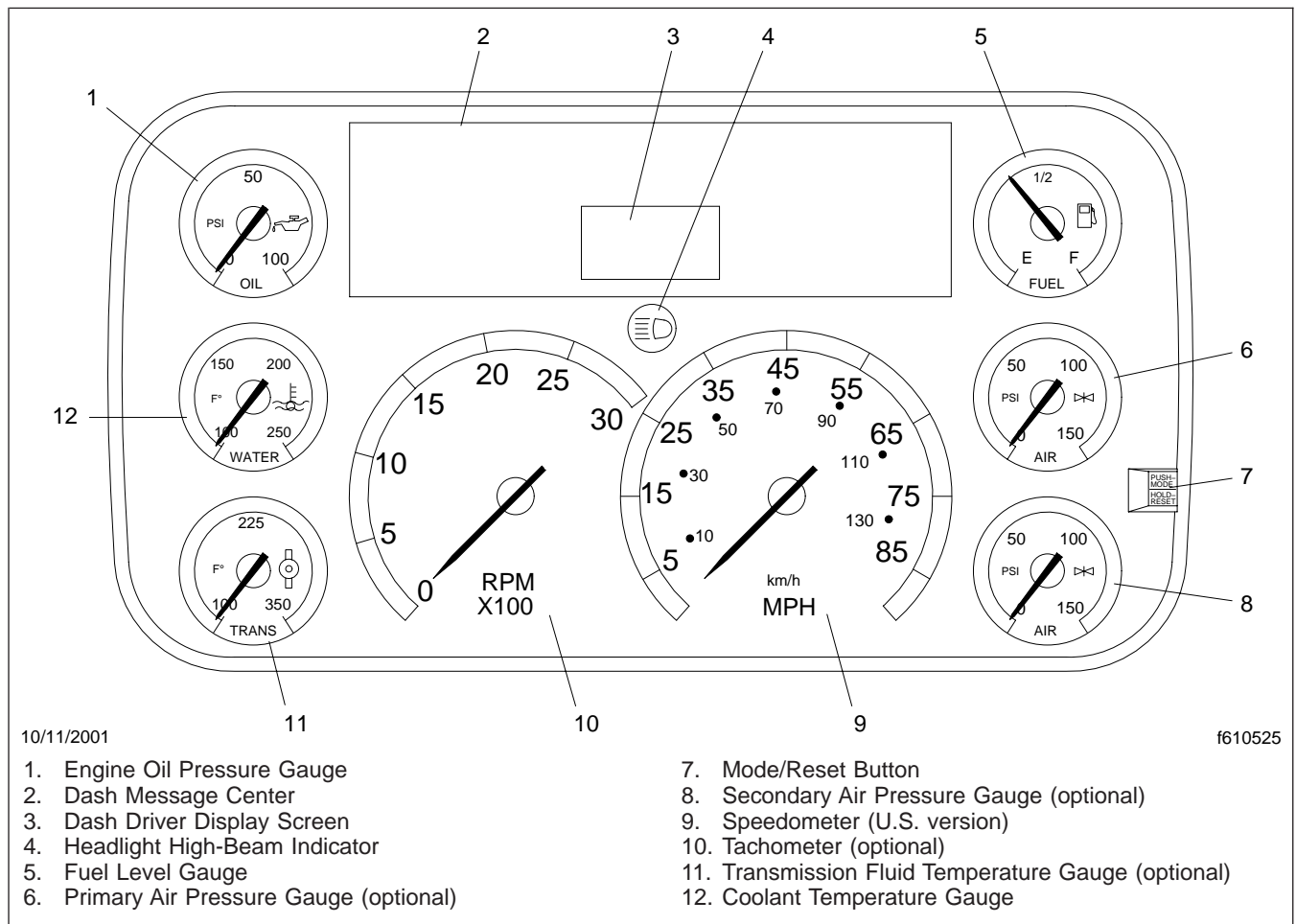

Fig. 1, ICU3 Gauge Layout (typical U.S.)

General Information

sweep 270 degrees, except for the tachometer, which sweeps 180 degrees. ICU3 gauge pointers and backlighting are lit by light emitting diodes (LEDs). The only serviceable parts on the ICU3 are the air pressure gauge module, the nine top center indicator lamps and lenses, and the Mode/Reset button.

Remote-Mounted (Satellite) Gauges

The ICU3 can drive external satellite gauges connected to the proprietary datalink between the ICU3 and the satellite gauges. Four pins are used for this function: gauge power, gauge ground, data, and backlighting. Optional satellite gauges include engine oil temperature, turbo boost, pyrometer, forward-rear axle temperature, rear-rear axle temperature, application air, axle lift, and suspension air pressure.

Awake State and Sleep State

The Bulkhead Module (BHM), Chassis Module (CHM), and instrumentation control unit (ICU) are, as a group, in an awake state or a sleep state depending on vehicle conditions. When any of these electronic components are awakened, the remaining components wake up if they are not already awake. When the BHM, CHM, and ICU are in an awake state, the odometer reading appears on the dash driver display screen.

One of the following actions will cause the BHM, CHM, or ICU to go into an awake state:

- opening the door
- turning on the hazard switch
- turning the ignition switch to any position other than OFF
- turning on the headlight/parking light switch
- depressing the service brake

The BHM, CHM, and ICU will enter a sleep state when they are no longer actively controlling any outputs or responding to any inputs and all other power down requirements are met.

To determine whether or not the electrical system is going into a sleep state, do the following.

1. Enter the vehicle.
2. Shut the doors.

3. Do not apply the service brakes.
4. Make sure the ignition switch and hazard switch are in the OFF position.

One minute after these conditions are met, and provided that one of the parameters in **Table 1** has not been added to the BHM, the odometer reading should disappear. If the odometer reading does not disappear, the electrical system is not going to sleep.

Parameters		
Parameter Part Number	Description	Hours
26-01017-002	Switched Center Pin Power	24
26-01019-003	Exterior Lighting	16,667
26-01019-004	Exterior Lighting	16,667
26-01019-005	Exterior Lighting	16,667

Table 1, Parameters

Dash Message Center

The dash message center includes the warning and indicator lights and a liquid crystal display (LCD). The LCD is used to display the odometer, voltmeter, and service information.

Mode/Reset Button

The Mode/Reset button, located on the right side of the instrument cluster, is used to scroll through the message center displays, and to manage driver information settings. When the parking brake is applied, the message center presents additional displays that are not available when the parking brake is off. The following lists the displays that are available on an EPA10 vehicle when the parking brake is applied.

- a. Trip distance
- b. Trip hours
- c. Temperature (EPA10 Only)
- d. Select screen
- e. Temperature alert screen
- f. Diagnostic screen
- g. Clear screen (with less than 254 miles)
- h. Engine miles

- i. Engine hours
- j. Set Up
- k. Back to odometer

Each press of the Mode/Reset button advances to the next display. Pressing and holding the Mode/Reset button in each display advances to any additional functions it may have. See subject 410 for detailed operation of the message center display screens.

Trip Miles

To reset trip miles and/or trip hours to zero, press and hold the Mode/Reset button for 1 second or longer.

Miles or Kilometers

To toggle between MI (miles) or KM (kilometers), press the Mode/Reset button while in the SELECT screen.

Fault Codes

When a fault code exists and the parking brake is applied, the display shows the message identifier (MID) on EPA07 and earlier vehicles, and the source address (SA) on EPA10 vehicles, of the ECU with the fault. For example, if the antilock brake system has a fault, the MID **AbS136** displays. If more than one ECU is reporting an active fault, the display cycles through the MIDs or SAs for each ECU.

Use the following instructions to display the active fault codes.

1. Press the mode/reset button until **DIAG n** displays. The letter "n" represents the number of active faults.
 2. Press and hold the mode/reset button once to display the MID/SA of the fault.
 3. Press the mode/reset button again to display details of the fault. Pre EPA10 vehicles will show the subsystem identifier (SID) or parameter identifier (PID). EPA10 vehicles will show the suspect parameter number (SPN).
 4. Press the mode/reset button again to display the failure mode indicator (FMI) of the fault.
 5. Press the mode/reset button again to return to the first fault display.
6. If more than one fault code is active, press and hold the mode/reset button to proceed to the next fault, then follow the previous four steps to display the additional faults.

Warning and Indicator Lights

The ICU3 has spaces for 28 warning and indicator lights. See **Fig. 2** for pre-EPA07 configuration, **Fig. 3** for EPA07 configuration, and **Fig. 4** for EPA10 configuration.

There are four rows of warning and indicator lights. The lights, or telltales, in the top row are optional. The light in position 8 (counting left to right across the top row) is a permanently mounted amber LED. The remaining top row indicators use replaceable incandescent lamps.

NOTE: Positions 1 through 8 are ground and databus-activated circuits. Position 9 is power activated and databus activated.

The lights on the other three rows are installed at fixed positions that do not vary. Some lights are optional. If an optional light is not requested, the position is blank (does not light up).

The following fixed-position lights are standard:

- stop engine warning (red)
- check engine indicator (amber)
- engine protection warning (red)
- low air pressure warning (red)
- low engine oil pressure warning (red)
- high coolant temperature warning (red)
- fasten seat belt warning (red)
- low battery voltage warning (red)
- parking brake on warning (red)
- tractor ABS indicator (amber)
- left-turn signal (green)
- right-turn signal (green)
- high beams on indicator (blue)

The following fixed-position lights are optional:

- air filter restriction indicator (amber)
- alternator no charge indicator (amber)

General Information

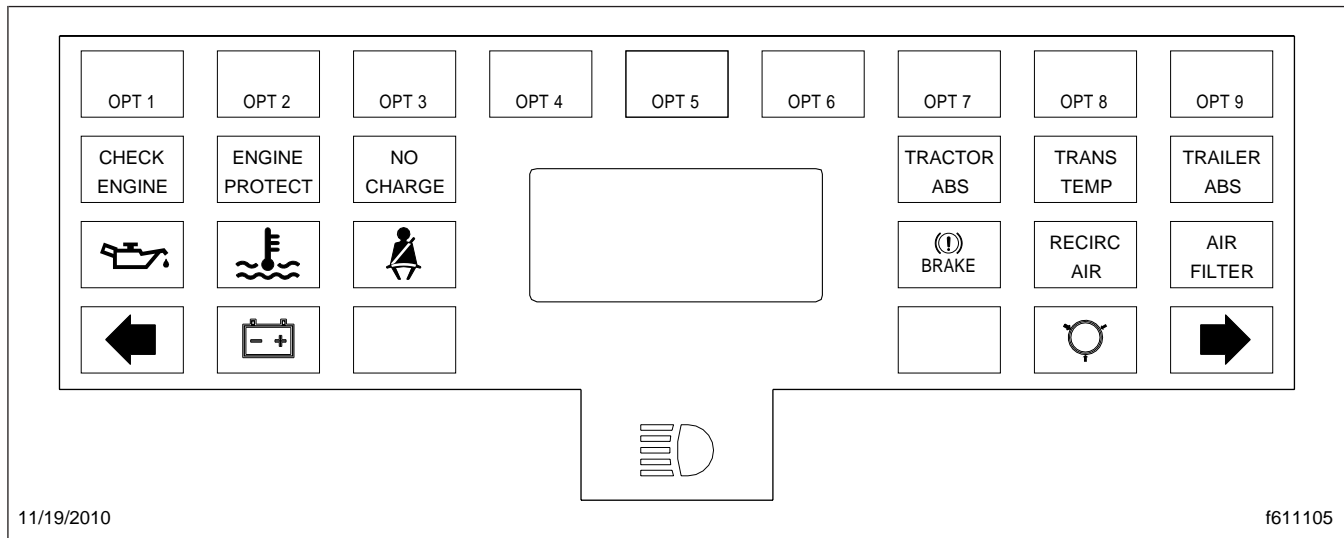

Fig. 2, Dash Message Center, ICU3 (pre-EPA07)

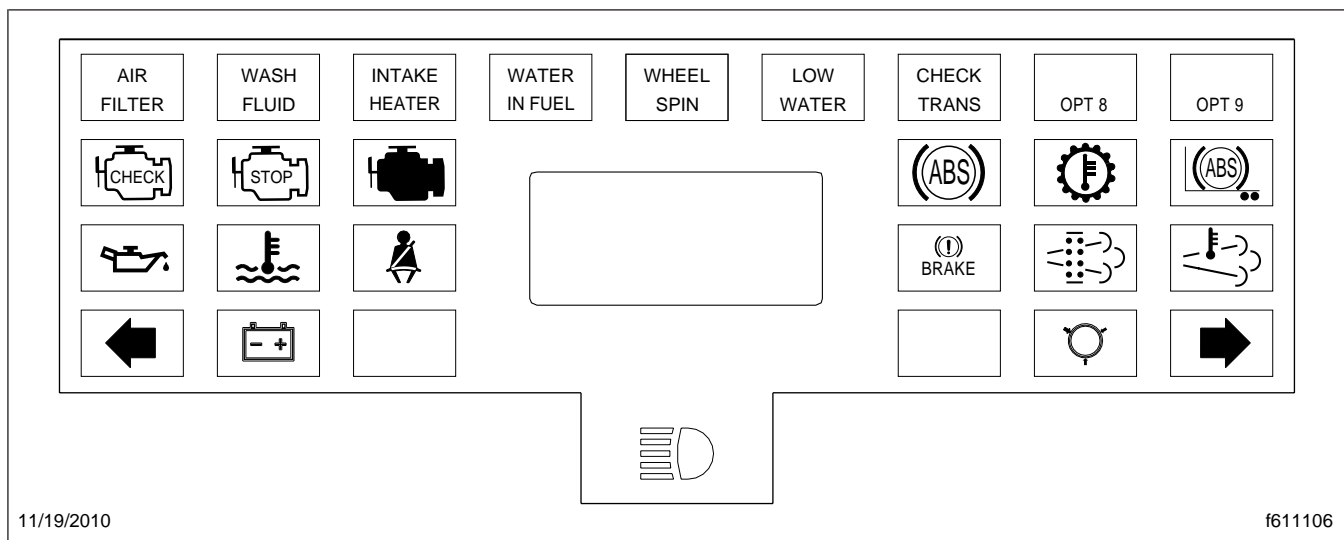

Fig. 3, Dash Message Center, ICU3 (EPA07)

- high transmission temperature warning (amber)—installed on vehicles with automatic transmissions
- recirculated air indicator (amber)
- trailer ABS indicator (amber)—installed on vehicles designed to be used with a trailer
- check transmission indicator (amber)
- intake heater indicator (amber)
- low washer fluid indicator (amber)
- optimized idle indicator (amber)
- wait to start indicator (amber)
- water in fuel indicator (amber)
- wheel spin indicator (amber)

The following lights are optional:

- low coolant level warning (red)
- electronic braking system (EBS) warning (red)

Other optional lights may be specified.

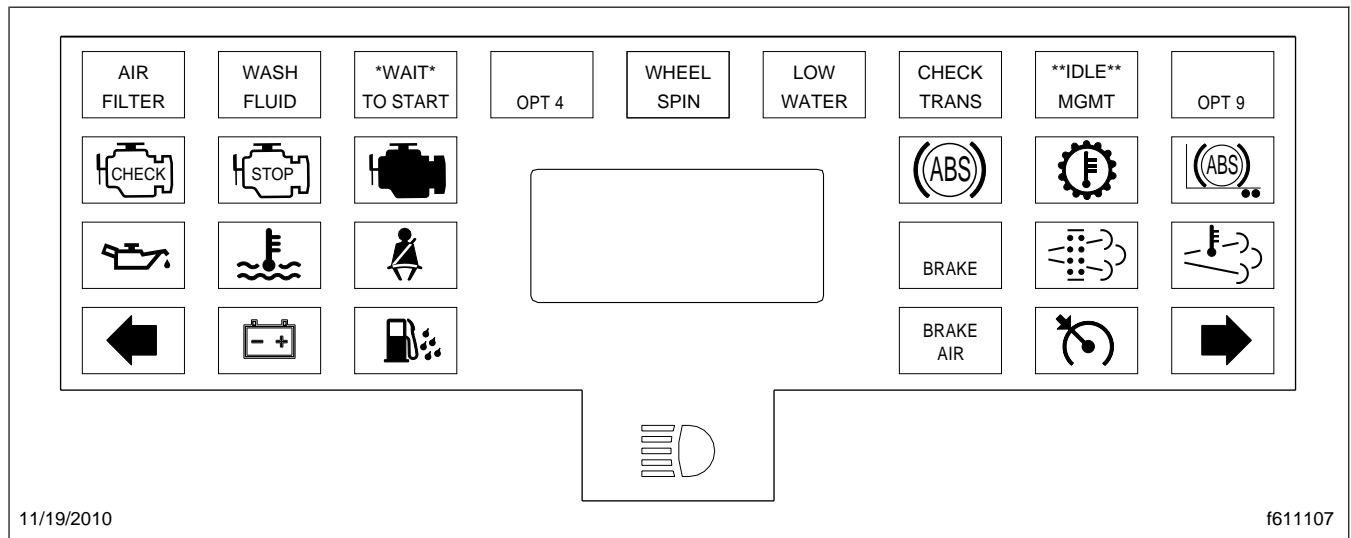

Fig. 4, Dash Message Center, ICU3 (EPA10)

Principles of Operation

Ignition Sequence

When the ignition is turned to ON, the ICU3 runs through the ignition sequence. See [Fig. 5](#).

If only the headlights are turned on, the dash driver display screen displays the odometer.

IMPORTANT: When the ignition is first turned to ON, all the electronic gauges complete a full sweep of their dials, the warning and indicator lights light up, and the buzzer sounds for three seconds when the seat belt is latched.

The following warning and indicator lights go on during the ignition sequence.

- low engine oil pressure warning
- high coolant temperature warning
- low air pressure warning
- parking brake on warning
- low battery voltage indicator
- fasten seat belt warning illuminates for 15 seconds (unless pin D10 is hardwired on EPA10 ICUs. If pin D10 is hardwired, the light will remain on for only three seconds when the seat belt is latched.)

- all engine warning lights, including engine protection, check engine, and stop engine
- all ABS warning lights, including wheel spin, tractor ABS, and trailer ABS (if installed); and
- the DEF level indicator on EPA10 vehicles will illuminate all segments green, then turn them off one at a time before turning the left most segment amber then red.

NOTE: While the engine and ABS warning lights go on during the ignition sequence, they are not controlled by the ICU3, but by their own system ECU.

Once the ignition has been turned to ON, the ICU performs a self-test, and polls the databus for faults.

During the first half of the self-test, all segments of the dash driver display screen illuminate as "888888.8". During the second half of the self-test, the software revision level is displayed.

If there are no active faults, the screen then displays the odometer.

If the ICU3 has received active fault codes from other devices, it displays the three-letter acronym for the device broadcasting the fault. It also displays the MID or SA number for each for three seconds, one after the other, until the parking brake is released or the ignition is turned to OFF.

General Information

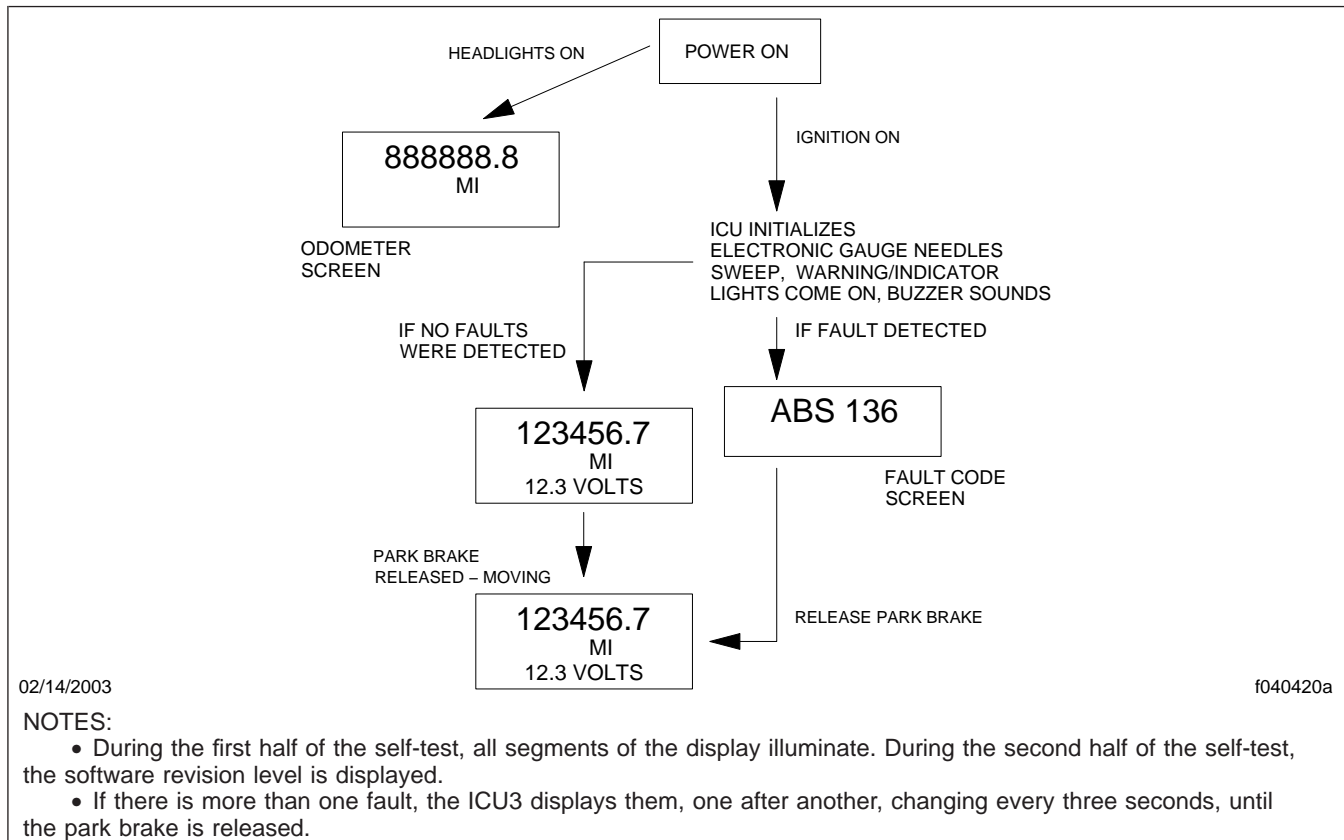

Fig. 5, ICU3 Ignition Sequence

The screen displays a code, called the message identifier (MID) for EPA07 and earlier vehicles, or source address (SA) for EPA10 and later vehicles. These identify the ECU or system that is broadcasting the fault code.

NOTE: If the ICU3 receives a message from an ECU that has not been preprogrammed into the memory of the ICU, it displays "SYS ###" instead, where ### is replaced by the MID/SA of the broadcasting device.

Once the parking brake is released, the ICU3 displays the odometer again.

Odometer

The odometer is set to display in either miles or kilometers, depending on the primary scale of the speedometer. The legend, either **MI** or **KM**, illuminates

between the odometer and the volts display when the engine is running or the headlights are turned on.

To toggle between MI (miles) or KM (kilometers), press the Mode/Reset button while in the SELECT screen.

The odometer is a seven-digit display with a decimal point until the vehicle has traveled 999,999.9 miles or kilometers (km). At one million miles (km), the odometer rolls over to "1000000" without the decimal point, and can continue up to 9,999,999. The odometer only displays significant figures (no leading zeros).

The ICU compares odometer data received from the engine controller to its own stored value. It will only alter its stored value if the difference is less than two miles (three km). When the ICU is replaced, the odometer display will start from zero even though the engine controller odometer may be a much larger value.

IMPORTANT: Although the odometer uses data supplied by the engine control module (ECM) to update its count, it keeps its own mileage starting from zero, when it was first installed. The ICU odometer may not match the engine ECU odometer. This may occur if the engine has been operated with the ICU disconnected, as may occur during factory break-in or engine service, or if the ICU has been replaced.

Buzzer/Chime

The buzzer sounds during the ignition sequence and whenever one of the following conditions exists:

- The engine oil pressure falls below the preset level, which is 5 to 9 psi (35 to 62 kPa) on most engines.
- The coolant temperature rises above the preset level, which is 215°F (102°C) on Caterpillar and Detroit Diesel engines, and 189°F (87°C) on MBE900 engines, and 225 to 230°F (107 to 110°C) on Cummins engines.
- The air pressure falls below the preset level of approximately 70 psi (483 kPa).
- The parking brake is set with the vehicle moving at a speed greater than 2 mph (3 km/h).
- The J1939 brake failure message is received from the ABS.
- The J1939 heartbeat message is not received from the ABS.
- The system voltage falls below 11.9 volts.
- An optional circuit connected to pin B12 will activate the buzzer when it is connected to ground.
- The door is open and the parking brake is not set.

ICU3 Removal and Installation

Removal

The instrumentation control unit, ICU3, is a one-piece unit, including housing, fixed gauges, a removable air gauge module, and the dash message center. See [Fig. 1](#).

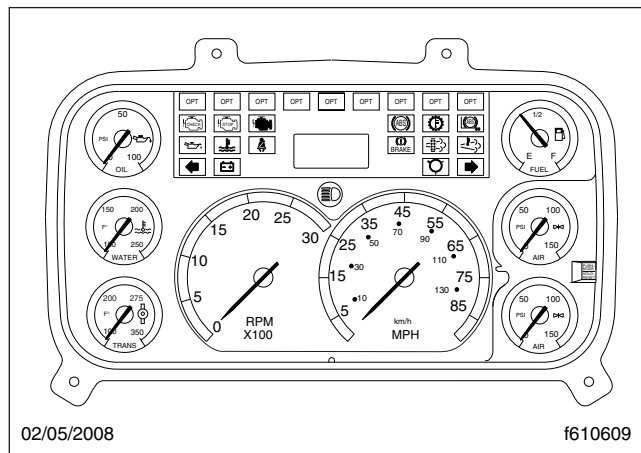

Fig. 1, ICU3, Front View

1. If replacing the ICU, attach a sticker to the driver side door frame indicating the mileage from the driver display, and the date that the ICU is being replaced.
2. Disconnect all negative leads from the batteries.

WARNING

Air lines under pressure can whip dangerously if disconnected. Drain all air from the air tanks before disconnecting air lines. Disconnecting pressurized air lines can cause personal injury and/or property damage.

3. Discharge the air pressure from the primary and secondary air tanks.
4. Remove the dash trim piece by removing the eleven screws that secure it. All fasteners for this procedure are 10–16 Torx® capscrews. See [Fig. 2](#).

NOTICE

Do not forcibly pull the ICU3 from the dash. This may dislodge electrical connections or air lines from the back of the ICU3, causing damage to connections, lines, or the dash.

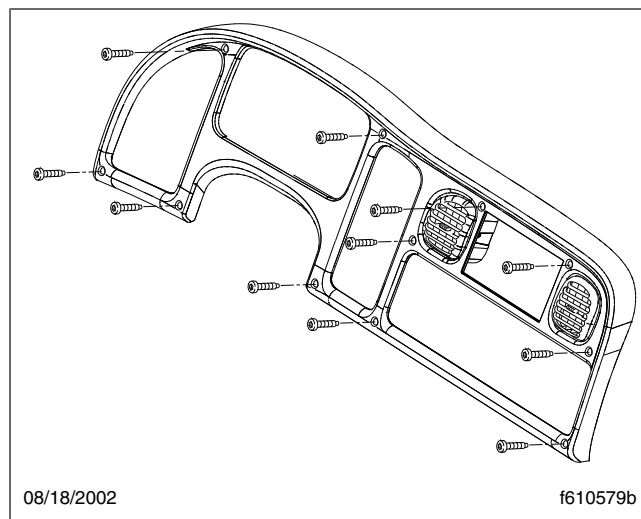

Fig. 2, Dash Trim Piece

5. Remove the four screws that secure the ICU. See [Fig. 3](#).

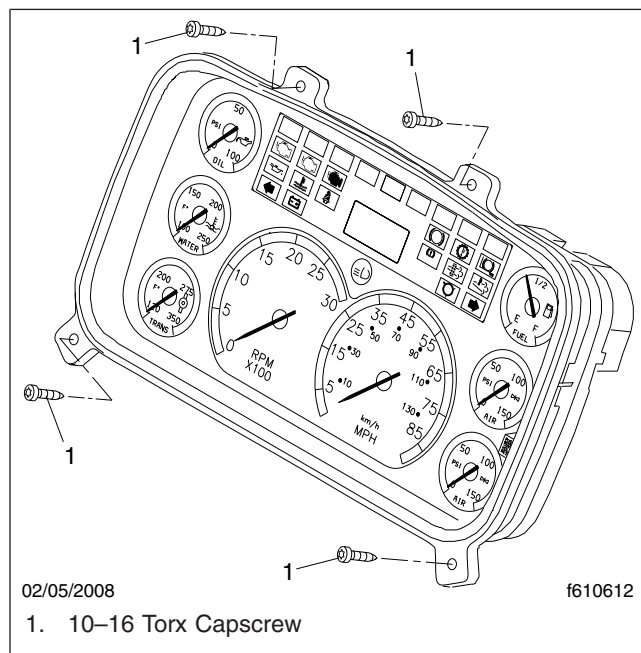

Fig. 3, ICU3 Installation

6. Disconnect the two electrical connectors from the back of the ICU. See [Fig. 4](#).
7. Remove the air lines by pressing the push-lock connectors, then pulling the air lines away from the gauges. The lines are color-coded for ease

54.11

Instrumentation Control Unit, ICU3

ICU3 Removal and Installation

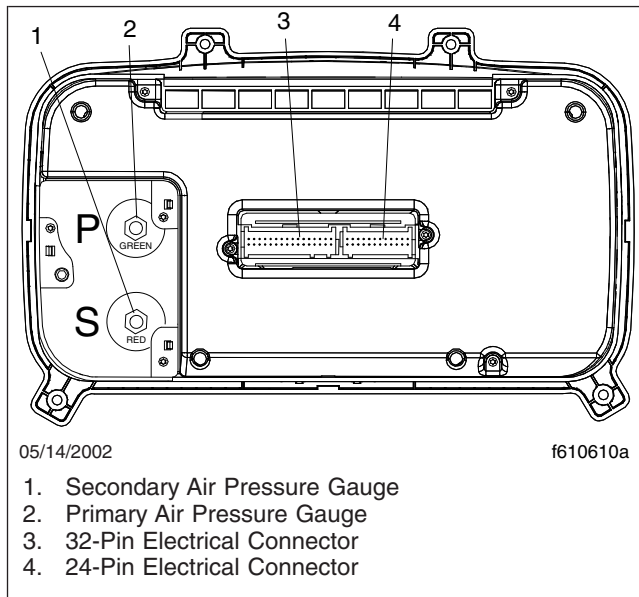

Fig. 4, ICU3, Rear View

of installation. The primary air line is green and is connected to the upper gauge. The secondary air line is red and is connected to the lower gauge.

Air Pressure Gauge Module Replacement

The air pressure gauge mode/reset button module may be replaced as a sub-assembly. See Fig. 5. This avoids the need to replace the entire ICU3.

NOTICE

NOTICE: Be careful not to damage the ribbon electrical connector or the air gauge needles when removing the air gauge module. The gauge needles are exposed once the module is removed. A thin-ribbon electrical connector connects the air gauge module and the ICU3 housing. Once the fasteners that secure the air gauge module are removed, take care in separating the module from the ribbon electrical connector. Do not separate the air gauges from module cover.

NOTE: Placing the cluster on a clean towel or cloth will help keep the plastic face from getting scratched during this procedure.

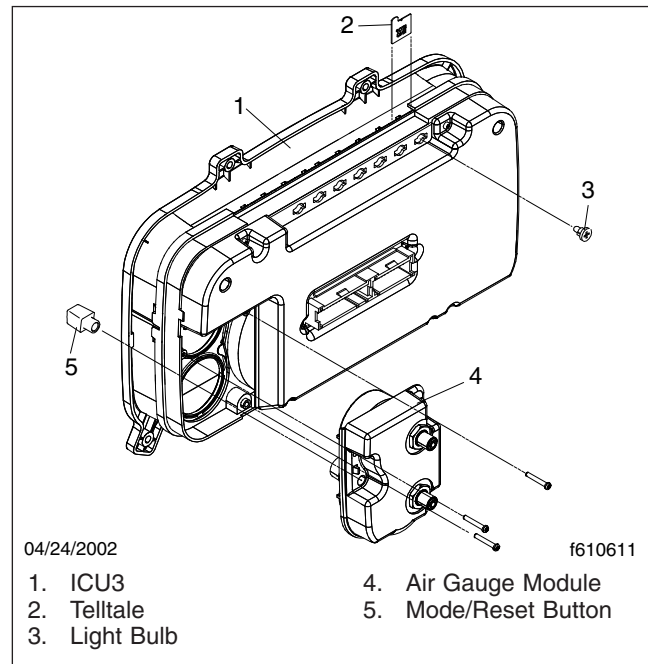

Fig. 5, ICU3, Rear View

1. Carefully place the ICU3 face down on a smooth surface and remove the three Torx® capscrews that secure the air gauge module to the ICU. See Fig. 6.

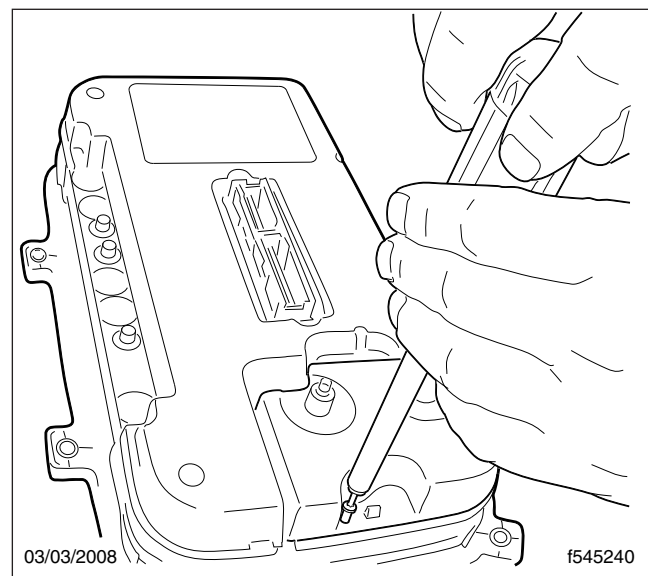

Fig. 6, Removing the T-8 Screws

ICU3 Removal and Installation

2. Separate the air gauge module slightly from the ICU to allow access to the electrical ribbon that connects the module to the ICU. See **Fig. 7**.
 3. Disconnect the electrical connection ribbon from the ICU, not from the air gauge module. Grip the ribbon firmly on each side and lift out, then remove the air gauge module.
 4. Position the air gauge module close to the opening it belongs in and connect the electrical ribbon connector in its slot. Gripping the ribbon end firmly, place the ribbon end into the slot and push it straight in until it stops.
 5. Place the air gauge module into its opening in the ICU3. Make sure the electrical ribbon is inside the module, and that the mode/reset button shaft in the ICU cavity lines up with the receptacle in the air gauge module.
 6. Install the three Torx capscrews and tighten them to secure the air gauge module.
 3. Place the ICU3 in the dash opening and secure it with the four capscrews. Tighten the capscrews 30 lbf-in (340 N·cm).
 4. Install the dash trim piece and secure it with eleven capscrews. Tighten the capscrews 30 lbf-in (340 N·cm).
 5. Connect the batteries.
- NOTE:** Mechanical (air) gauges do not make a sweep.
6. Turn on the ignition and test the operation of the cluster. All electronic gauges should make one complete sweep and return to their normal indicating positions. The warning and indicator lights should turn on, then off, as described in **Subject 050**.
 7. Start the engine and verify proper operation of the air gauge module as the air pressure builds.

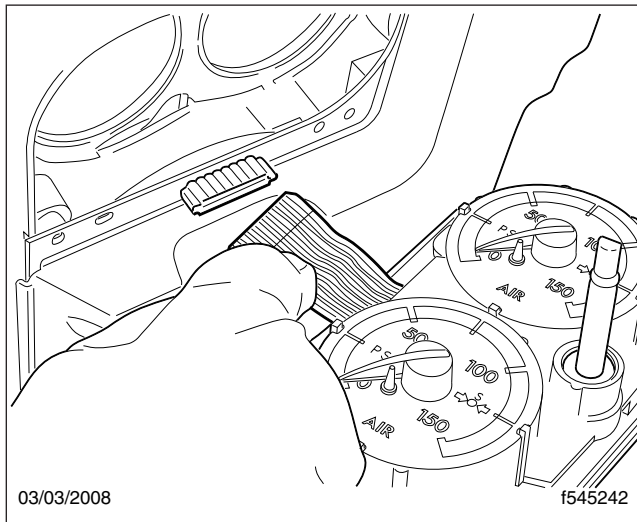

Fig. 7, Disconnecting the Ribbon Cable

Installation

1. Connect the air lines to the air gauges by pressing them firmly into the push-lock connector on the back of the gauge. The green air line connects to the primary (upper) gauge. The red air line connects to the secondary (lower) gauge. See **Fig. 4**.
2. Connect the electrical connectors to the back of the ICU3.

Lamp and Telltale Replacement

Background Information

The instrumentation control unit, ICU3, is a one-piece unit, including housing, fixed gauges, a removable air gauge module, and the dash message center. See [Fig. 1](#).

NOTE: Since the top-row warning and indicator lamps are optional, some positions in the row may not have a lamp and telltale.

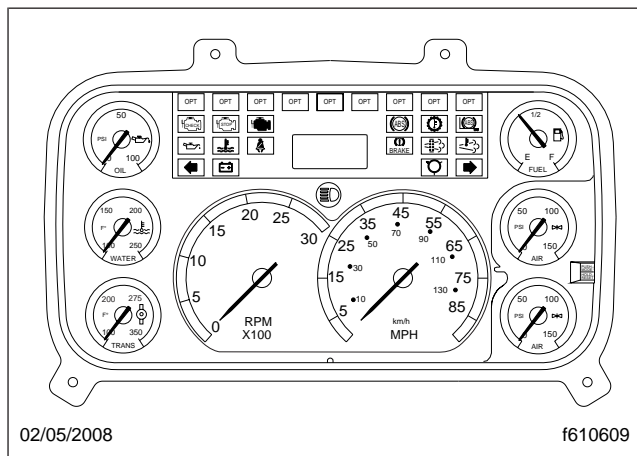

Fig. 1, ICU3

The nine top-row warning and indicator lamps are all replaceable except for the lamp in position 8, counting left to right. The lamp in that position is a permanent LED.

The term "telltale" refers to the small plastic bezel in the top row with a warning or indicator message printed on it. Telltales are replaceable.

IMPORTANT: If more extensive service work on the ICU3 is required, the electrical and air gauge connections must be disconnected. See [Subject 100](#) for instructions.

NOTICE

Do not forcibly pull the ICU3 from the dash. This may dislodge electrical connections or air hoses from the back of the ICU3, causing damage to the connections, the air hoses, or the dash.

Lamp Replacement

1. Disconnect the negative leads from the batteries and discharge the pressure from the air tanks.
2. Remove the dash trim piece by removing the 11 capscrews that secure it. All fasteners for this procedure are 10–16 Torx® capscrews. See [Fig. 2](#).

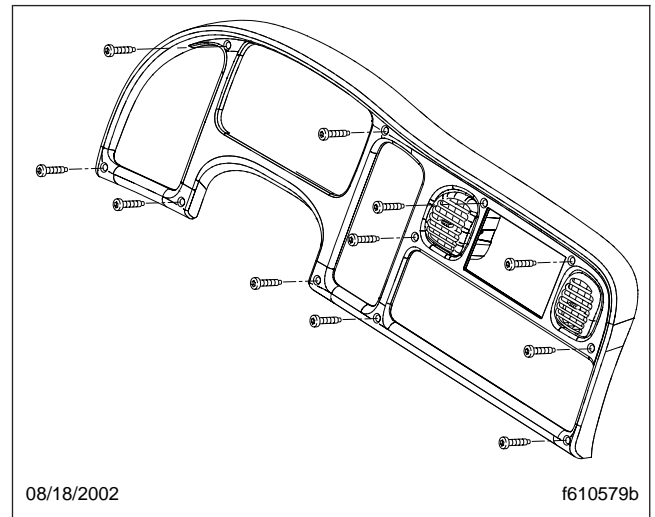

Fig. 2, Dash Trim Piece

3. Remove the four capscrews that secure the ICU3. See [Fig. 3](#).
4. Place a clean towel over the front of the ICU3 before pulling it forward to prevent scratches. Carefully pull the ICU3 forward to access the top row of lamps and telltales.
5. Use a small screwdriver or flat blade to twist out the lamp by its base behind the telltale. Turn the lamp one-quarter turn and remove. See [Fig. 4](#).
6. Place a new lamp in the opening and twist it one-quarter turn.
7. Using capscrews, install the ICU3.
8. Using capscrews, install the dash trim piece.
9. Connect the batteries.

Telltale Replacement

1. Disconnect the negative leads from the batteries and drain the air tanks.

54.11

Instrumentation Control Unit, ICU3

Lamp and Telltale Replacement

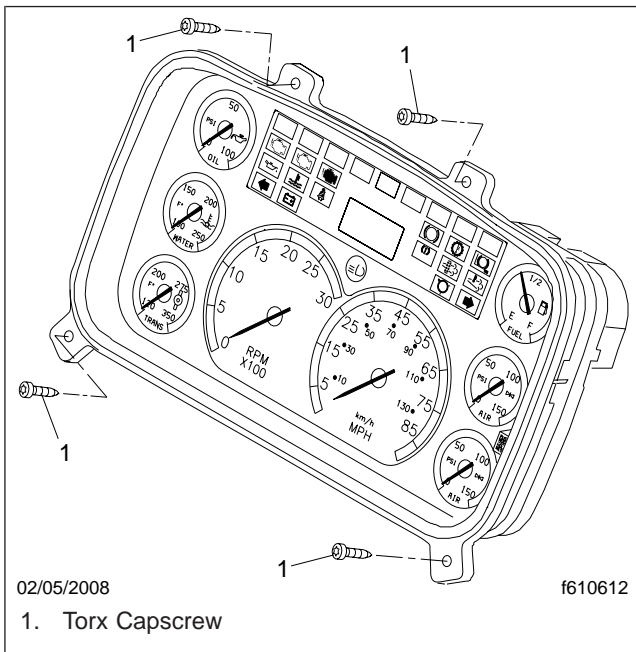

Fig. 3, ICU3 Installation

3. Remove the four capscrews that secure the ICU3. See [Fig. 3](#).
4. Place a clean towel over the front of the ICU3 before pulling it forward to prevent scratches. Carefully pull the ICU3 forward to access the top row of lamps and telltales.
5. Using a pair of needlenose pliers or a similar tool, grab the exposed tab at the top of the telltale slot and carefully pull the telltale out from the top of the ICU. See [Fig. 4](#).
6. Place a new telltale in the slot the same way it was removed. Properly orient the telltale so the text is readable from the front, then grab the top tab of the telltale and slide it into the slot.
7. Using capscrews, install the ICU3.
8. Using capscrews, install the dash trim piece.
9. Connect the batteries.
10. Turn the ignition on. Check all lamps and telltales for correct operation.

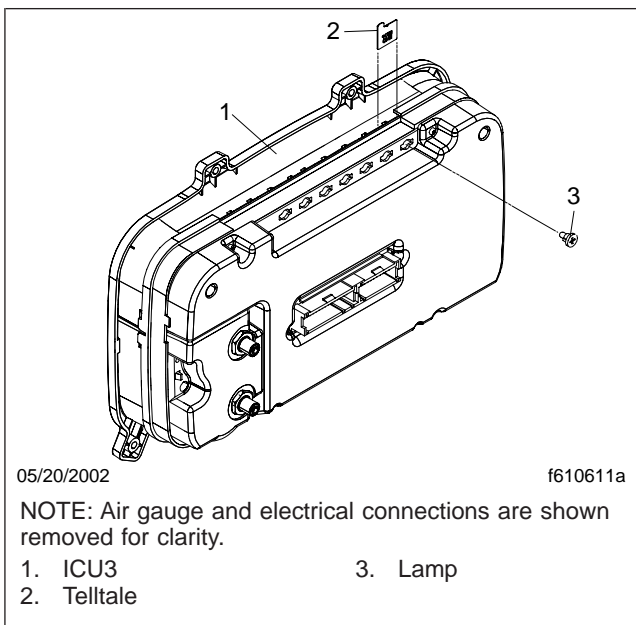

Fig. 4, ICU3, Rear View

2. Remove the dash trim piece by removing the 11 capscrews that secure it. All fasteners for this procedure are 10–16 Torx® capscrews. See [Fig. 2](#).

IMPORTANT: Begin troubleshooting the ICU using [Table 1](#).

ICU Instrumentation Troubleshooting – Start Here		
Problem Type	Symptom	Procedure to Use
Fault Code	A fault code is displayed on the ICU display	Table 14
	A Roll Call fault is present – Examples are "no ENG" or "no ABS"	Table 14
	"nO DATA" is displayed on the LCD	Table 14
	"nO J1939" is displayed on the LCD	Table 14
	"- - - - -" (seven dashes) is displayed on the LCD	Table 14
Gauges	Problem with a gauge in the ICU	Table 2
	Problem with a satellite gauge	Table 6
Backlighting	Problem with backlighting in the ICU	Table 19
	Problem with backlighting in a remote gauge	Table 19
Warning Indicators	Problem with an in-gauge indicator	Table 23
	Problem with an indicator in the ICU	Table 22
	Problem with the seat belt lamp	Table 24
	Problem with the DEF indicator	Table 12
LCD Display	A segment of the LCD does not work	Table 20
	The LCD is completely inoperative	Table 20
Mode/Reset Button	The mode/reset button is sticking or does not change the display	Table 21

Table 1, ICU Instrumentation Troubleshooting – Start Here

Gauge Diagnosis

ICU Gauge Diagnosis – Start Here			
Test	Test Procedure	Test Result	Action
1	Turn the ignition on without starting the engine. All the gauges, except air pressure gauges, should sweep full scale and back in unison. Do the gauges sweep correctly when the ignition is turned on, and does the DEF indicator cycle?	Yes	Go to Test 3.
		No	Go to Test 2.
2	Is the ICU completely nonresponsive?	Yes	Test for battery power-on pin D14, ignition power-on pin D15, and the ground on pin D13. Troubleshoot and repair any fault with these circuits as necessary. If these circuits are all working, replace the ICU.
		No	Replace the ICU.

54.11

Instrumentation Control Unit, ICU3

Troubleshooting

ICU Gauge Diagnosis – Start Here			
Test	Test Procedure	Test Result	Action
3	Use Table 3 to determine the gauge input source. Use the troubleshooting action based on the gauge input.	Fuel Level	Go to Table 8 .
		DEF Level	Go to Table 12 .
		Air Pressure	Go to Table 7 .
		Sensor Driven	Go to Table 9 .
		Data Driven	Go to Table 10 .

Table 2, ICU Gauge Diagnosis – Start Here

[Table 3](#) defines where each gauge, standard or optional, receives its input signal. Some gauges are datalink-driven, meaning the information is sent to the instrument cluster from some other ECU. Other

gauges are controlled by a sensor wired directly to the instrument cluster or an air line connected directly to the gauge.

Standard and Optional Gauges: Input Source to ICU		
Gauge	EPA07 and Earlier Input	EPA10 J1939 Input
Ammeter*	Not part of the ICU	Not part of the ICU
Application Air Pressure	Air line connected to gauge	Air line connected to gauge
DEF Level	N/A	J1939 from engine (SA 00 SPN 1761) or J1939 from aftertreatment control module (ACM) (SA 61 SPN 1761)
Engine Coolant Temperature	J1587—from engine (MID 128 PID 110)	J1939 from engine (SA 00 SPN 110)
Engine Oil Pressure	J1587—from engine (MID 128 PID 100)	J1939 from engine (SA 00 SPN 100)
Engine Oil Temperature	J1587—from engine (MID 128 PID 175)	J1939 from engine (SA 00 SPN 175)
Forward Rear-Axle Temperature	Sensor connected to ICU	Sensor connected to ICU
Fuel Level	Sensor connected to ICU	Sensor connected to ICU
Low DEF Indicator	N/A	J1939 from engine (SA 00 SPN 5245)
Primary Air System Pressure	Air line connected to gauge	Air line connected to gauge
Pyrometer	J1587—from engine (MID 128 PID 173)	J1939 from engine (SA 00 SPN 3241)
Rear Rear-Axle Temperature	Sensor connected to ICU	Sensor connected to ICU
Secondary Air System Pressure	Air line connected to gauge	Air line connected to gauge
Speedometer	J1587—from engine (MID 128 PID 84)	J1939 from engine (SA 00 SPN 84)
Suspension Air Pressure	Air line connected to gauge	Air line connected to gauge
Tachometer	J1587—from engine (MID 128 PID 190)	J1939 from engine (SA 00 SPN 190)
Transmission Oil Temperature	Manual, Eaton, and AGS - sensor connected to ICU Allison, and G transmissions - Data from transmission ECU	Manual, Eaton, and AGS - sensor connected to ICU Allison, and G transmissions - Data from transmission ECU SPN 177

Standard and Optional Gauges: Input Source to ICU		
Gauge	EPA07 and Earlier Input	EPA10 J1939 Input
Turbo Boost Pressure	J1587datalink—from engine (MID 128 PID 439)	J1939 from engine (SA 00 SPN 102)

* Ammeter is a stand-alone gauge that is not connected to the ICU.

Table 3, Standard and Optional Gauges: Input Source to ICU

Satellite Gauge Diagnosis

The ICU is capable of controlling up to eight additional gauges located in the dash panels. These gauges are controlled by a databus with backlighting, power, and ground sourced by the ICU. See [Table 4](#).

Satellite gauges that are sensor or data driven will initialize at power-on with the same sequence as the

gauges in the main ICU3. The air pressure gauges only use the backlighting power from the ICU3. If there is a short circuit in any of the satellite gauges or the interconnecting wiring harness, it is possible that none of the gauges will work.

Satellite Gauge Daisy Chain Circuits		
Connector/Pin	Name	Function
C6	Gauge Power	12 volt source for satellite gauges
C7	Gauge Ground	Ground supply for satellite gauges
D6	Illumination	Backlighting voltage source for satellite gauges
D7	Gauge Data	Databus to satellite gauges

Table 4, Satellite Gauge Daisy Chain Circuits

[Table 5](#) identifies the satellite gauges that may be used with the ICU.

ICU Satellite Gauges	
Gauge	Input Source
Engine Oil Temperature	Data from the engine controller
Turbo Boost Pressure	Data from the engine controller
Pyrometer	Data from the engine controller
Forward Rear-Axle Temperature	Sensor connected to ICU
Rear Rear-Axle Temperature	Sensor connected to ICU
Application Air Pressure	Air line connected to gauge
Suspension Air Pressure	Air line connected to gauge
Lift Axle Air Pressure (up to 4)	Air line connected to gauge

Table 5, ICU Satellite Gauges

Troubleshooting

Satellite Gauge Diagnosis			
Test	Test Procedure	Test Result	Action
1	Turn the ignition to ON without starting the engine. All the satellite gauges, except air pressure gauges should sweep full scale and back in unison. Do the electrical satellite gauges sweep correctly when the ignition is turned to ON?	Yes	Go to Test 3.
		No	Go to Test 2.
2	Are all the electrical satellite gauges nonresponsive?	Yes	Troubleshoot for a short in the satellite gauge wiring by testing for ignition voltage on pin C6 and ground on pin C7. Disconnect the satellite gauges one at a time to troubleshoot for a short in a gauge that could be taking the databus down. Repair any wiring fault or replace any defective gauge. If no problem was found, replace the ICU.
		No	Troubleshoot for a fault in the connection to the inoperative gauge and repair as appropriate. Otherwise, replace the inoperative gauge.
3	Use Table 5 to determine the gauge input source. Use the troubleshooting procedure based on the gauge input.	Air Pressure	Go to Table 7 .
		Sensor Driven	Go to Table 9 .
		Data Driven	Go to Table 10 .

Table 6, Satellite Gauge Diagnosis

Air Pressure Gauge Diagnosis

Air Pressure Gauge Diagnosis			
Test	Test Description	Test Result	Action
1	Which air pressure gauge is not functioning correctly?	Primary or Secondary	Go to Test 2.
		Application	Go to Test 3.
		Suspension	Go to Test 4.
		Lift Axle Pressure	Go to Test 5.
2	Drain the air tanks. Connect an accurate pressure gauge to the primary or secondary air tank depending on which gauge has a problem. Start the engine and build air pressure until the compressor cuts out. Is the air pressure gauge in the cluster within 11 psi (76 kPa) of the test gauge?	Yes	Gauge is OK. No problem found.
		No	Check air line to gauge for kinks, pinches, or wire ties that are crushing the air line feed. If OK, replace the air pressure gauge module.

Air Pressure Gauge Diagnosis			
Test	Test Description	Test Result	Action
3	Connect an accurate pressure gauge to a delivery port on the foot valve. Make a 90 psi (621 kPa) brake application while observing the application air pressure gauge in the cluster and the test gauge. Is the air pressure gauge in the cluster within 11 psi (76 kPa) of the test gauge?	Yes	Gauge is OK. No problem found.
		No	Check air line to gauge for kinks, pinches, or wire ties that are crushing the air line feed. If OK, replace the air pressure gauge.
4	Connect an accurate pressure gauge to the air suspension. Is the air pressure gauge in the cluster within 11 psi (76 kPa) of the test gauge?	Yes	Gauge is OK. No problem found.
		No	Check air line to gauge for kinks, pinches, or wire ties that are crushing the air line feed. If OK, replace the air pressure gauge.
5	Raise the lift axle. Connect an accurate pressure gauge to the application side of the lift axle air system. Lower the axle and adjust the pressure. Is the axle pressure on the instrument panel gauge within 11 psi of the test gauge?	Yes	If the pressure cannot be controlled with the adjustment knob, check the reverse switch and pressure dump valve. Check the pressure adjustment regulator, replace if it is not controlling the pressure. Otherwise, there is no problem.
		No	Check air line to gauge for kinks, pinches, or wire ties that are crushing the air line feed. If OK, replace the air pressure gauge.

Table 7, Air Pressure Gauge Diagnosis

Fuel Level Gauge Diagnosis

The fuel level gauge is controlled by the ICU using a variable resistance input from the fuel level sending unit that is located in the fuel tank. The fuel level sending unit resistance increases from $31\pm 2\Omega$ with a full tank to $247\pm 3\Omega$ when empty.

If the ICU3 is measuring a resistance greater than 284Ω between circuit 47 and ground, the EPA10 cluster will set a fault for fuel level circuit open. If the ICU3 is measuring less than 23.5Ω between circuit 47 and ground, the EPA10 cluster will set a fault for fuel level circuit shorted low. ServiceLink may be used to monitor for these faults on EPA10 J1939 clusters. On all model years of clusters, the gauge will read empty until the measurement from the sensor is between 284Ω and 23.5Ω . Refer to [Table 8](#) for the fuel level diagnostic procedure.

NOTE: If the fuel level sensor is below the minimum resistance (short to ground) or above the maximum (open), the fuel gauge will read empty. Shorting the fuel sensor wires will not drive the gauge to full scale.

Clogged vents or fuel lines will cause a delay on fuel tank equalizing, resulting in inaccurate fuel gauge readings.

Changes with the fuel level will not be indicated by the fuel gauge for 60 seconds. The 60-second delay applies to activation and deactivation unless ignition power is cycled, then it will immediately indicate for the measured value.

Troubleshooting

Fuel Level Gauge Diagnosis			
Test	Test Procedure	Test Result	Action
1	<p>If a 100 ohm resistor is available, disconnect the fuel level sender connector and place the resistor across circuit 47 and ground in the wiring harness connector to simulate the fuel level sending unit. Turn the ignition to the ON position and observe the fuel gauge. If, after gauge initialization, the gauge points closely to the 1/2 tank mark, then the wiring and ICU are all operating correctly. If there is no problem with the wiring and ICU, go to Test 4.</p> <p>Does the fuel level gauge stay at empty even though there is fuel in the tank or is the complaint an inaccurate and intermittent reading?</p> <p>Note - turn the ignition to OFF and disconnect the batteries before continuing.</p>	Stays at Empty	Go to Test 2.
		Inaccurate or Intermittent	Go to Test 4.
2	<p>Disconnect the connector at the fuel level sender and measure the resistance of the sender.</p> <p>What is the resistance of the sender?</p>	Greater Than 246Ω or Less Than 30Ω	Go to Test 4.
		Between 246Ω and 30Ω	Go to Test 3.
3	<p>Connect the fuel level sender and disconnect the connectors on the back of the ICU. Measure the resistance in the vehicle wiring between circuit 47 in connector pin D1 and the ground circuit in connector pin D2.</p> <p>What is the resistance of the circuit?</p>	Greater than 246Ω	Troubleshoot and repair an open circuit on either circuit 47 or the ground between the ICU connector and the fuel level sender.
		Between 246Ω and 30Ω	This is the valid resistance range. If the fuel tank is full and the resistance is close to 31Ω, replace the ICU. Otherwise, verify mechanical integrity of the fuel sender. Go to Test 5.
		Less than 30Ω	Troubleshoot and repair a short to ground on circuit 47 between the ICU connector and the fuel level sender.
4	<p>Remove the fuel level sending unit from the fuel tank. Connect an ohm meter to the pins at the fuel level sender connector. Slowly move the level of the float arm from full to empty. See Fig. 1. Does the resistance increase smoothly, without spikes, from 31±2Ω to 247±3Ω?</p>	Yes	Troubleshoot and repair for corrosion or an intermittent connection in the circuitry between the ICU and the fuel level sender. Go to Test 5.
		No	Replace the fuel level sender.
5	<p>Is the fuel tank rotated or the fuel sender float arm bent or interfering with the tank wall, return tubes or aux heater line?</p> <p>The fuel tank should be oriented such that the fuel sender is at the top.</p>	Yes	Correct the condition causing incorrect fuel gauge readings.
		No	The fuel gauge is reading correctly.

Table 8, Fuel Level Gauge Diagnosis

Sensor-Driven Gauge Diagnosis

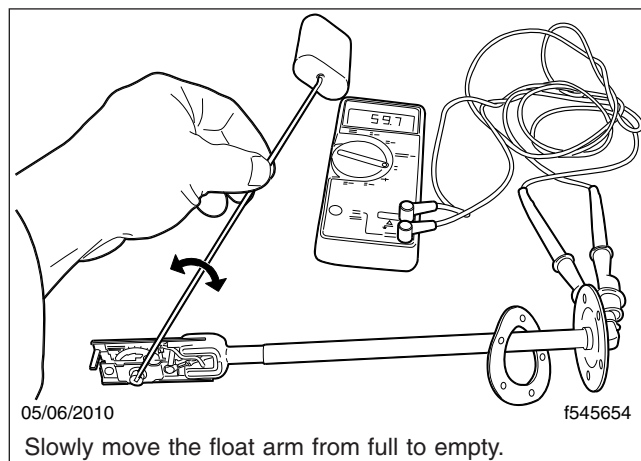

Fig. 1, Testing the Fuel Level Sending Unit

Sensor-Driven Gauge Diagnosis			
Test	Test Procedure	Test Result	Action
1	Does the gauge stay pegged at the full scale or the bottom of scale reading even though the temperature is at some mid-point or is the complaint an inaccurate reading? Note: Turn the ignition to OFF and disconnect the batteries before continuing.	Stays Pegged	Go to Test 2.
		Inaccurate	Go to Test 3.
2	Disconnect the connector at the sensor and measure the resistance of the sensor. Does the sensor measure open, shorted, or some mid-range resistance for that sensor, using the table in Specifications 400 ?	Open or Shorted	Replace the sensor.
		Mid-Range Resistance	Locate and repair the wiring fault for that sensor. Use the circuit and pin information tables in Specifications 400 to identify the circuits to troubleshoot.
3	Remove the sensor and place it in a container of water with a thermometer and heat to a temperature where the resistance can be accurately measured with an ohm meter. Use the resistance table in Specifications 400 for the sensor under test to determine if the measured resistance is appropriate for the temperature. Does the resistance value match the table value?	Yes	Measure the resistance of the wiring between the ICU and the sensor connector. Locate and repair a partially open or short circuit.
		No	Replace the sensor.

Table 9, Sensor-Driven Gauge Diagnosis

Troubleshooting

Data-Driven Gauge Diagnosis

Data-Driven Gauge Diagnosis			
Test	Test Procedure	Test Result	Action
1	If the problem is with the DEF level indicator, use the procedure in Table 12 . Connect ServiceLink and open the datalink monitor template for the instrument cluster. Start the engine and let it run until the operating condition should register on the gauge. For example, oil temperature must be above the minimum position on the gauge. Is the display on the computer within 5% of the position of the gauge in the ICU?	Yes	Use the troubleshooting procedure for the sensor giving incorrect data. For example, use the engine manufacturer's troubleshooting procedure for sensors connected to the engine controller.
		No	Replace the ICU.

Table 10, Data-Driven Gauge Diagnosis

DEF Level Indicator Diagnosis

The DEF level indicator is integrated into the fuel gauge, and uses J1939 data from the ACM. The DEF level is measured by a sealed non-contact variable-resistance sensing assembly located in the DEF tank. The DEF level sensor resistance can be measured at the tank connector. For Detroit Diesel engines, the level sensor signal uses pins 1 and 2. For Cummins engines, the level sensor uses either pins 1 and 2 or 1 and 4 depending on the part. See [Table 13](#) to determine which pins to use. On Detroit Diesel engines, when the DEF tank is empty, the sensor will measure approximately 240Ω. When full,

it will measure approximately 19.8KΩ. On Cummins engines, when the DEF tank is empty, the sensor will measure approximately 4.8KΩ. When full, it will measure approximately 68Ω, depending on the unit part number. Use the resistance to float height listed in [Table 13](#) to test the resistance for a specific float height. When there is no DEF in the tank or when there is a fault in the DEF level sensing circuit, the indicator will flash the red segment until the fault is corrected, or a sufficient amount of DEF is added to the tank. Perform the recommended action in [Table 11](#) to troubleshoot faults with the DEF level sensing circuitry indicated by fault codes with SPN 1761.

DEF Level Faults from SA 0 or SA 61				
SPN	FMI	Description	Behavior	Action
1761	1 17 18 31	DEF level low	The DEF level is low. MIL, CEL, STOP engine lamp, and engine derate may be active.	The DEF tank has run too low. Fill the DEF tank so that it is at least 25% full and idle the engine for 5 minutes. If the problem is still present use the DEF level diagnostic procedure in Table 12 .
1761	3	DEF level circuit out of range high	The voltage on circuit 532F is greater than the ACM expects.	Troubleshoot circuits 532F and 532F- between the ACM and the temperature level sensor for a wiring fault and also for an open level sensor unit.
1761	4	DEF level circuit out of range low	The voltage on circuit 532F is close to 0 volts.	Troubleshoot circuit 532F between the ACM and the temperature level sensor for a wiring fault and also for a shorted level sensor unit.

Table 11, DEF Level Faults from SA 0 or SA 61

DEF Level Diagnostic Procedure			
Test	Test Procedure	Test Result	Action
1	Turn the ignition to ON but do not start the engine. Does the DEF level indicator illuminate all segments green, then turn them off beginning from the right, one at a time until the left one becomes amber then red, before either showing a mid-range level, or flashing the left segment red?	Yes	The DEF level indication display is working properly. Go to Test 2.
		No	Replace the ICU3.
2	Use Servicelink to check for any J1939 faults. Is there a fault for SPN 1761 with FMI 3 or 4 (DEF level sensor out of range) or are any J1939 communications fault codes active? NOTE: SPN 1761 FMI 1, 17, 18, or 31 indicate the DEF level is low. There is no wiring fault but there may be a problem with DEF level indication accuracy.	Yes	If the code is for a FMI 4, troubleshoot for a wiring fault in circuit 532F between the DEF level sensor and the ACM. If the code is FMI 3, go to Test 3. If there is a J1939 communications fault, use the troubleshooting information in this manual to locate and repair communications.
		No or Accuracy Problem	Go to Test 4.
3	Turn the ignition to OFF then disconnect the 4 wire connector at the DEF level sender. Use a short jumper wire to short pins 1 and 2 (for Detroit Diesel engine) or the pins indicated by part number in Table 13 (for Cummins engine) together in the vehicle harness side of the connector. Turn the ignition on without starting the engine. Allow the indicator initialization sequence to complete, then check for fault codes. Is there an active fault for SPN 1761 FMI 4?	Yes	The wiring indicates continuity. Go to Test 4.
		No	Troubleshoot and repair for an open in circuit 532F and/or circuit 532F- between the DEF level sensor and the ACM.
4	Turn the ignition to OFF and disconnect the batteries. Remove the temperature/level sender unit from the DEF tank. Connect an ohm meter to pins 1 and 2 (for Detroit Diesel engine) or the pins indicated by part number in Table 13 (for Cummins engine) at the 4 pin connector. Slowly raise the level of the float from empty to full. Record the resistance range measured. Does the vehicle have a Cummins or a DD engine?	Cummins	If the resistance did not vary as shown in Table 13 , replace the temperature/level sender.
		Detroit Diesel	If the resistance did not vary from approximately 240Ω at empty to 19.68KΩ at the full position, replace the temperature/level sender unit.

Table 12, DEF Level Diagnostic Procedure

DEF Level Sensor Resistance Measurement				
Engine Type	Detroit		Cummins	
Part Number	04-27881-000			
	A04-27943-000			
	A04-27943-001	A04-27445-000	A04-27942-000	04-30774-001
	04-30774-000			04-30798-001
	04-30798-000			

Troubleshooting

DEF Level Sensor Resistance Measurement				
Engine Type	Detroit	Cummins		
Test at Sensor Connector Pins NOTE: Pins are numbered left to right.	1 and 2	1 and 4	1 and 4	1 and 2
Resistance: Float at top of travel	~19800Ω	~68Ω	~68Ω	~68Ω
Resistance: Float at center of travel	~2035Ω	~730Ω	~743Ω	~742Ω
Resistance: Float at bottom of travel	~240Ω	~4812Ω	~4809Ω	~4732Ω

Table 13, DEF Level Sensor Resistance Measurement

Fault Code Diagnosis

The ICU3 will display fault codes that are broadcast from other devices on the databus. Follow the procedure in [Table 14](#) to determine if there is a problem with the ICU3, another device on the databus, a sensor that is connected to the ICU, or with the databus itself. Fault codes that are generated by the ICU3 can be read using ServiceLink.

Some circuitry faults within the ICU3 will cause the LCD to display "- - - - -" (seven dashes). Replace the ICU3 when this is displayed.

Roll call faults occur when the ICU3 is not receiving data from a device that had been on the databus in

the past. If a device has been removed from an EPA10 vehicle (Qualcomm for example), perform the resetEE procedure from the ICU3 setup menu. See [Subject 410](#) for details of this procedure. Roll call fault messages are originated by the ICU3 for display only. They are not broadcast over the databus and cannot be read by ServiceLink or any other data analysis tool.

Fault codes originated by other devices are echoed on the display when the ignition is first turned ON and the parking brake is set. [Table 17](#) and [Table 18](#) identify the most common ECUs that would broadcast these faults.

Fault Code Diagnosis			
Test	Test Procedure	Test Result	Action
1	Is the fault code from MID 140 on an EPA07 or earlier vehicle, or from SA 23 on an EPA10 vehicle, or some other fault?	MID 140	Use Table 15 to identify the fault code and the troubleshooting procedure.
		SA 23	Use Table 16 to identify the fault code and the troubleshooting procedure.
		Other	Go to Test 2.
2	Does the display only show seven dashes (- - - - -) or some other message?	Dashes	The ICU has an internal error. Replace the ICU.
		Other Message	Go to Test 3.
3	Is the message "nO dATA" or another message showing nO something?	Yes	If the message is "nO dATA" or "nO J1939", the ICU is unable to communicate with any other device on the vehicle. Troubleshoot the databus for loss of function. If the message is something with a 3-letter code, for example "no ENG" there is a roll call fault. A roll call fault will show SID 254 Fail 07 on J1587 systems and SPN 639 FMI 07 on J1939 vehicles. Use Table 17 for EPA07 and earlier and Table 18 for EPA10 vehicles to identify the device that is not communicating and causing a roll call fault.
		No	Go to Test 4.

Fault Code Diagnosis			
Test	Test Procedure	Test Result	Action
4	Is the vehicle an EPA07 or earlier, or an EPA10?	EPA07 or Earlier	Use Table 17 to identify the device broadcasting the fault code. Refer to the troubleshooting subject for that device to determine how to proceed for the fault it is broadcasting.
		EPA10	Use Table 18 to identify the device broadcasting the fault code. Refer to the troubleshooting subject for that device to determine how to proceed for the fault it is broadcasting.

Table 14, Fault Code Diagnosis

EPA07 ICU J1587/J1708 Fault Codes MID 140 (ICU)			
SID/PID	FMI	Description	Behavior
P168	1	Low System Voltage	The vehicle voltage measured by the ICU is less than 10.5 volts.
ACTION: Troubleshoot the vehicle charging system. Test the alternator, and test for voltage drop in the alternator cables and battery cables. If the vehicle is equipped with a remote sense circuit to the alternator, check the fuse for circuit 123E.			
S240	12	EEPROM Memory Fault	The ICU has an internal memory fault. The display may show "- - - - -", (seven dashes).
ACTION: Replace the ICU.			
S254	12	Internal Electronics Fault	The ICU microprocessor or other internal critical electronics has a fault. The display may show "- - - - -", (seven dashes).
ACTION: Replace the ICU.			

Table 15, EPA07 ICU J1587/J1708 Fault Codes MID 140 (ICU)

ICU3 J1939 Fault Codes SA 23 (ICU)				
SPN	FMI	Conn/Pin	Description	Behavior
96	5	D1 (+) D2 (-)	Fuel Level Circuit Open	The resistance between pins D1 and D2 is greater than 298 ohms. The gauge will point to empty.
ACTION: Use the troubleshooting procedure in Table 8 beginning at Test 4.				
96	6	D1 (+) D2 (-)	Fuel Level Circuit Short	The resistance between pins D1 and D2 is less than 23.5 ohms. The gauge will point to empty.
ACTION: Disconnect the fuel level sensor connector at the sending unit. Turn the ignition to ON and check the fault code display. If the fault code for fuel level circuit short (FMI 6) is still active, locate and repair the short in circuit 47 between the LBCU and the fuel level sender. Otherwise use the troubleshooting procedure in Table 8 beginning at Test 4.				
168	1	n/a	Low Voltage	The ICU is measuring a system voltage of less than 12.0 volts.
ACTION: Troubleshoot the charging system and test the battery cables for voltage drop.				
177	6	C12 (-) C13 (+)	Transmission Temp Sensor Short	The resistance between pins C12 and C13 is less than 70 ohms. The gauge will point full scale.
ACTION: Troubleshoot for a shorted transmission temperature sensor and for a short to ground in circuit 30.				
628	12	n/a	ICU Internal Memory Fault	The ICU has an internal memory fault. The display may show "- - - - -", (seven dashes).

54.11

Instrumentation Control Unit, ICU3

Troubleshooting

ICU3 J1939 Fault Codes SA 23 (ICU)				
SPN	FMI	Conn/Pin	Description	Behavior
ACTION: Replace the ICU.				
629	12	n/a	ICU Internal Electronics Fault	The ICU microprocessor or other internal critical electronics has a fault. The display may show "- - - - -", (seven dashes).
ACTION: Replace the ICU.				
639	7	n/a	Roll Call Fault	Any other J1939 device that the ICU expects on the network but is not broadcasting will generate a fault code. The source address will be of the device that the ICU is not receiving messages from. Note that this is actually an ICU-generated fault code.
ACTION: If a device has been removed from the vehicle or if a used ICU is installed, a roll call reset must be performed. Use the "rESEt EE" Screen in the setup menu. If a J1939 device is not broadcasting due to an error, use the troubleshooting procedure for that device to determine the cause of it going off-line.				
2567	0	n/a	Excessive Broadcast Announce Messages (BAM)	Another device on the J1939 databus is transmitting an excessive number of fault messages that are intended for the ICU.
ACTION: Use ServiceLink or scroll through the fault codes that the ICU3 displays to determine which controller has many fault codes. Use the appropriate troubleshooting procedures for that controller to repair its system.				

Table 16, ICU3 J1939 Fault Codes SA 23 (ICU)

EPA07 and Earlier Displayed Fault Messages			
Message	System With Active Fault	Message	System With Active Fault
ECU 128	Engine Control Unit (engine control module)	rAd 221	Radio
tCU 130	Transmission Control Unit	tSU 223	Transmission Shift Unit
AbS 136	Antilock Brake System	CEL 231	Cellular Phone
SAT 181	Satellite Communications (Qualcomm)	SbU 232	Seat Belt Unit (SPACE/Airbag system)
CdU 219	Collision Detection Unit (VORAD)	SYS ###	Generic—system not defined in this table

Table 17, EPA07 and Earlier Displayed Fault Messages

EPA10 Displayed Fault Messages			
Message	System With Active Fault	Message	System With Active Fault
EnG 0	Engine Controller – CPC	EEC 61	Aftertreatment Control Module (ACM)
EnG 1	Engine Controller – MCM	CEL 74	Cellular Phone
tCU 3	Transmission Control Unit	SAt 75	Satellite Communications
tSU 5	Transmission Shift Unit	rAd 76	Radio
AbS 11	Antilock Brake Controller	SbU 83	Seat Belt Unit – Space

EPA10 Displayed Fault Messages			
Message	System With Active Fault	Message	System With Active Fault
CdU 42	Collision Detection Unit	SYS ###	Where ### is the source address of any other J1939 controller that is not in this list.

Table 18, EPA10 Displayed Fault Messages

Gauge Backlighting Diagnosis

Gauge Backlighting Diagnosis			
Test	Test Description	Test Result	Action
1	Is only the air pressure gauge module backlighting affected?	Yes	Go to Test 2.
		No	Go to Test 3.
2	Remove the three air gauge module screws and carefully lift the air gauge module off the back of the ICU while leaving the ribbon cable connected. Inspect the ribbon cable connection to the ICU PC board. Make sure that it is plugged in all the way. Is the ribbon cable connection OK?	Yes	Replace the air pressure gauge module.
		No	Repair the ribbon cable connection as necessary.
3	Turn the headlights on and press the dimmer switch to increase then decrease the backlighting. Is the backlighting inoperative for all of the HVAC, headlight switch, and ICU?	Yes	Use the troubleshooting procedures in Section 54.30 .
		ICU only	Go to Test 4.
4	Access the back of the ICU and disconnect the two electrical connectors. Turn the headlights on. Measure voltage between pins A1(+) and D3(-) while increasing and decreasing the dimmer switch. The voltage should range between approximately 2.5V (dim) and 11.3V (full bright). Does the measured voltage change through this range?	Yes	Replace the ICU.
		No	Go to Test 4.
5	Measure voltage between pin A1(+) and a known good ground while increasing and decreasing the dimmer switch. The voltage should range between approximately 2.5V (dim) and 11.3V (full bright). Does the measured voltage change through this range?	Yes	Repair backlighting ground circuit to ICU pin D3 as necessary.
		No	Troubleshoot circuit 29A between BHM and ICU. Repair the wiring as appropriate.

Table 19, Gauge Backlighting Diagnosis

LCD Diagnosis

Troubleshooting

LCD Diagnosis			
Test	Test Procedure	Test Result	Action
1	Turn the headlights ON with the ignition in the OFF position. Does the LCD light up and display mileage?	Yes	Go to Test 2.
		No	Turn the ignition to ON without starting the engine. If the LCD initializes all segments, then use the troubleshooting procedure in Section 54.12 to troubleshoot the ICU wakeup feature. Otherwise go to Test 2.
2	Turn the ignition to ON without starting the engine. Do all the segments of the LCD turn on and initialize or is the LCD completely inactive?	Only some segments initialize	Replace the ICU.
		LCD completely inactive	Test for battery power-on pin D14, ignition power-on pin D15, and the ground-on pin D13. Troubleshoot and repair any fault with these circuits as necessary. If these circuits are all working, replace the ICU.
		All segments initialize	There is no problem with the LCD or there is a more appropriate symptom to troubleshoot such as backlighting.

Table 20, LCD Diagnosis

Mode/Reset Button Diagnosis

Mode/Reset Button Diagnosis			
Test No.	Test Description	Test Result	Action
1	Press the Mode/Reset button several times to determine if it is sticking or binding. Does the button move freely?	Yes	Go to Test 2
		No	Remove the button cap and inspect for foreign substance in the shaft area. Clean as necessary. It may be necessary to remove the air gauge module from the ICU to clean the shaft and grommet.
2	Follow the procedure in Subject 110 to remove the gauge module from the ICU. Note the ribbon cable connection when the gauge module is removed. Is the ribbon cable completely connected?	Yes	Replace the gauge module.
		No	Properly connect the ribbon cable and test the Mode/Reset button operation. Install the repaired ICU if it now works. Otherwise replace the gauge module.

Table 21, Mode/Reset Button Diagnosis

Warning and Indicator Lamps Diagnosis

Use [Table 22](#) to determine if an indicator lamp has a power-on bulb check and how it is activated.











The ICU does not set fault codes for lamps that are inoperative. If an indicator does not illuminate, use the **Activation** and **Control Pin** information to deter-

mine if the problem is the signal that drives the lamp or if the lamp itself is inoperative.

For data-driven indicators, use ServiceLink to monitor the data for the indicator. If the ICU does not illuminate an indicator when ServiceLink shows that it is on, there is a problem with the indicator. The top row lamps are replaceable, for the others, the ICU must be replaced.

For indicators that are hardwired, monitor the voltage at the ICU input pin. Use the **Activation** column information to determine when the indicator should illuminate. Troubleshoot the vehicle wiring harness or











switch as necessary. Indicators with a power-on bulb check (even though they are LEDs) are confirmed to work.

ICU Warning and Indicator Lamps					
Lamp	Symbol	Bulb Check	Activation	Control Pin	Buzzer Operation
Left Turn Signal		NO	Lamp is ON when 12V is applied to the control pin or lamp is ON when commanded over J1939 from the BHM.	C8	Beep sound when control pin is at 12V or commanded from the BHM
Right Turn Signal		NO	Lamp is ON when 12V is applied to the control pin or lamp is ON when commanded over J1939 from the BHM.	D8	Beep sound when control pin is at 12V or commanded from the BHM
High Beam		NO	Lamp is ON when 12V is applied to the control pin or lamp is ON when commanded over J1939 from the BHM.	A12	None
Park Brake		YES	Lamp is ON when commanded over J1939 from the ABS Controller or from the BHM.	Data	Buzzer active when vehicle speed is greater than 2 MPH (3 km/h) (Uses speed data from ABS)
Low Air Pressure		YES	Lamp is ON when commanded over J1939 from the BHM.	Data	Buzzer active whenever lamp is ON
Battery Voltage		YES	Lamp is ON when system voltage has been less than 12 volts for longer than 40 seconds. The message is broadcast by the engine controller.	Data	Buzzer active whenever lamp is ON
Fasten Seat Belt		YES	If pin D10 is not hardwired to seat belt buckle, lamp is ON for 15 seconds at power up only. If pin D10 is hardwired, the bulb check is 3 seconds long and the lamp is OFF when ground is applied to the control pin.	N/A or D10	Friendly chime for 10 seconds when pin D10 is hardwired if park brake is off and seat belt is not latched
Check Engine Lamp (CEL)		YES	Lamp is ON when ground is applied to the control pin or Lamp is ON/FLASHING when commanded by the engine controller.	C15 and Data	None
Malfunction Indicator Lamp (MIL)		YES	Lamp is ON when ground is applied to the control pin.	A9	None
Stop Engine		YES	Lamp is ON when ground is applied to the control pin or Lamp is ON/FLASHING when commanded by the engine controller.	C16 and Data	None

54.11

Instrumentation Control Unit, ICU3

Troubleshooting

ICU Warning and Indicator Lamps					
Lamp	Symbol	Bulb Check	Activation	Control Pin	Buzzer Operation
Tractor ABS		YES	Lamp is ON when ground is applied to the control pin or Lamp is ON when commanded by the tractor ABS controller. The lamp will also be ON when the ICU is not receiving data from the ABS controller.	B11 and Data	None
Trailer ABS		YES	Lamp is ON when ground is applied to the control pin or Lamp is ON when commanded by the trailer ABS controller.	D12 and Data	None
Cruise Control		YES	Lamp is ON when the cruise enable switch is in the ON position.	B9	None
DPF Regeneration (REGEN)		YES	Lamp is ON when ground is applied to the control pin or Lamp is ON/ FLASHING when commanded by the engine controller.	C10 and Data	None
High Exhaust Temperature		YES	Lamp is ON when ground is applied to the control pin or Lamp is ON/ FLASHING when commanded by the engine controller.	A5 and Data	None
Water In Fuel (EPA10)		NO	Lamp is ON when ground is applied to the control pin or Lamp is ON when commanded by the engine controller.	C9 and Data	None
Low Oil Pressure		YES	Lamp is ON when commanded by the engine controller. The lamp will latch on for a minimum of 30 seconds.	Data	Buzzer is active when the lamp is ON
High Coolant Temperature		YES	Lamp is ON when commanded by the engine controller. The lamp will latch on for a minimum of 30 seconds.	Data	Buzzer is active when the lamp is ON
High Transmission Temperature		YES	Lamp is ON when ground is applied to the control pin or Lamp is ON/ FLASHING when commanded by the transmission controller or the retarder.	A4 and Data	None
Option 1 (Air Filter Restriction)		NO	Lamp is ON when ground is applied to the control pin or Lamp is ON when commanded by the BHM SA 33, SPN 5086.	C14 and Data	None
Option 2 (Washer Fluid Low)		NO	Lamp is ON when ground is applied to the control pin or Lamp is ON when commanded by the BHM SA 33, SPN 80.	A6 and Data	None







ICU Warning and Indicator Lamps					
Lamp	Symbol	Bulb Check	Activation	Control Pin	Buzzer Operation
Option 3 (EPA07 and earlier - Intake Heater EPA10 - Wait to Start)	 	NO	Lamp is ON when ground is applied to the control pin or Lamp is ON when commanded by the engine controller SA 0, SPN 1081.	A7 and Data	None
Option 4 (EPA07 and Earlier - Water In Fuel)		NO	Lamp is ON when ground is applied to the control pin or Lamp is ON when commanded by the BHM SA 33 SPN 5086.	A8 and Data	None
Option 5 (Wheel Spin)		NO	Lamp is ON when ground is applied to the control pin or Lamp is ON when commanded by the BHM SA 33.	B1 and Data	None
Option 6 (Low Water)		NO	Lamp is ON when ground is applied to the control pin or Lamp is ON when commanded by the engine controller SA 0.	B8 and Data	None
Option 7 (Check Transmission)		YES	Lamp is ON when ground is applied to the control pin or Lamp is ON when commanded by the transmission controller	C11 and Data	None
Option 8 (Idle Management)		NO	Lamp is ON when ground is applied to the control pin.	C1 and Data	None
Option 9	—	NO	—	D4 and Data	None

Table 22, ICU Warning and Indicator Lamps

In-gauge lamps illuminate during power-on initialization, and when the data to the gauge indicates a fault, or an out-of-normal-range condition. An illumi-

nated in-gauge lamp indicates that immediate attention is necessary.

ICU In-Gauge Warning Lamps			
Lamp	Bulb Check	Input Source	Activation
Low Fuel Level	YES	Fuel Level Sensor	When the fuel level is less than 1/8th of a tank, the lamp will be ON. A 60-second delay applies to activation and deactivation unless ignition power is cycled and it will immediately indicate for the measured value.
Low DEF Level	YES	Data	When the DEF level is less than 15% of tank capacity, the low DEF light will be ON. When DEF level is less than 5% of tank capacity, the low DEF light will flash.

Table 23, ICU In-Gauge Warning Lamps

54.11

Instrumentation Control Unit, ICU3

Troubleshooting

Seat Belt Lamp Troubleshooting			
Test	Test Procedure	Test Result	Action
1	Turn the ignition to OFF, then turn it to the ON position without starting the engine. Does the lamp always stay on, never illuminate, or only illuminate for 3 to 15 seconds at power-on?	Always ON	The ICU has learned that it is in a vehicle that has a seat belt buckle switch hardwired to ICU pin D10. Troubleshoot for an open seat belt buckle switch or open circuit between the seat belt buckle and the ICU. If the vehicle does not have a hardwired seat belt buckle switch, perform the ICU3 reset EE procedure as described in Specifications 400 .
		Never ON	The lamp itself is open circuit, replace the ICU3.
		Only ON 3 to 15 seconds	A vehicle that does not have a hardwired seat belt buckle switch illuminates the lamp for 15 seconds at power-on. A vehicle that has a hardwired seat belt switch illuminates this lamp for 3 seconds at power-on and then will turn it off if the seat belt input is at ground (seat belt connected). There is no problem with the lamp circuit if it operates according to this description.

Table 24, Seat Belt Lamp Troubleshooting

Figure 1 is an overview schematic of the ICU3 as it is connected to the vehicle.

The two ICU3 main cab harness connectors are pink and plug into pins located in the center of the unit on the back. Connector-1 has 24 cavities numbered A1 through A12 and B1 through B12. See **Table 1**.

Connector-2 has 32 cavities, numbered C1 through C16, and D1 through D16. See **Table 2**.

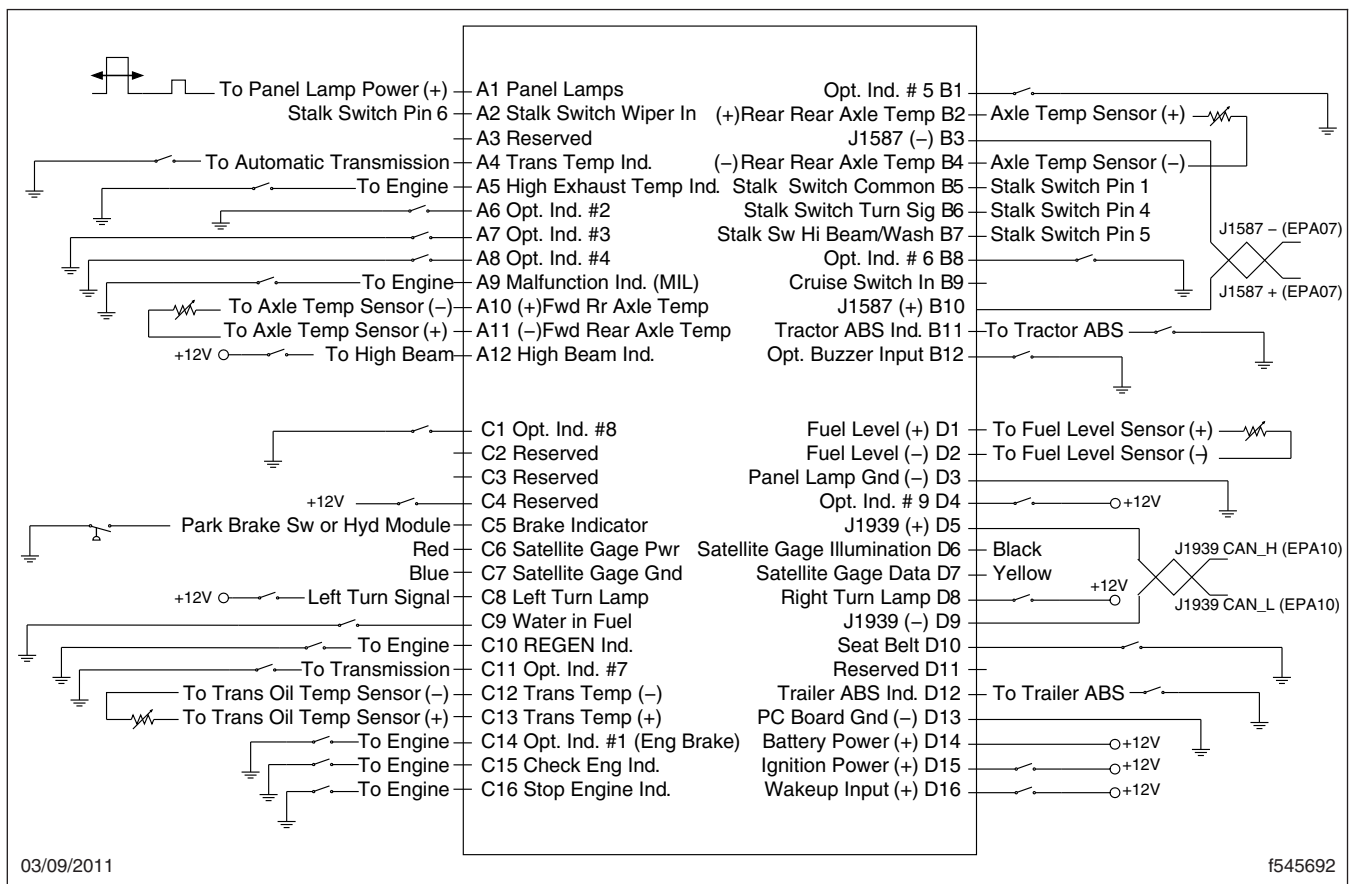

Fig. 1, ICU3 Overview Schematic

54.11

Instrumentation Control Unit, ICU3

Specifications

ICU3 Connector-1 Pin Assignments, Pins A1 Through B12		
Pin	Description	Wire
A1	Panel Backlight Power (+)	29A
A2	Multifunction Turn Signal Switch Wiper Input	473C
A3	Reserved	18B
A4	Transmission High Temperature Indicator	30A
A5	High Exhaust Temperature Indicator	429L
A6	Optional Indicator 2	376T
A7	Preheater Relay 1 Coil Signal (optional indicator 3)	431B1
A8	Optional Indicator 4	—
A9	Malfunction Indicator Lamp (MIL)	400
A10	Fwd Rear-Axle Temperature (+)	42
A11	Fwd Rear-Axle Temperature (-)	42G
A12	High Beam Indicator	222A
B1	Wheel Spin Warning Lamp (optional indicator 5)	376S
B2	Rear Rear-Axle Temperature Sensor (-)	43
B3	J1708 Network (-)	—
B4	Rear Rear-Axle Temperature Sensor (+)	43G
B5	Multifunction Turn Signal Switch Common Input	473
B6	Multifunction Turn Signal Switch Turn Signal Input	473A
B7	Multifunction Turn Signal Switch High Beam/Washer Input	473B
B8	Optional Indicator 6	—
B9	Cruise Control Switch Input	440D
B10	J1708 Network (+)	—
B11	Tractor ABS Indicator	376L
B12	Optional Buzzer Input	29G

Table 1, ICU3 Connector-1 Pin Assignments, Pins A1 Through B12

ICU3 Connector-2 Pin Assignments, Pins C1 Through D16		
Pin	Description	Wire
C1	Optional Indicator 8	E115
C2	Reserved	—
C3	Reserved	—
C4	Reserved	—
C5	Park Brake Indicator	125S
C6	Satellite Gauge Drive Power	Red
C7	Satellite Gauge Drive Gnd	Blue

ICU3 Connector-2 Pin Assignments, Pins C1 Through D16		
Pin	Description	Wire
C8	Left Turn Indicator	38J
C9	Water In Fuel Indicator	286
C10	REGEN Indicator	492J
C11	Wheel Spin Warning Lamp (optional indicator 7)	376S
C12	Transmission Oil Temperature (-)	30G
C13	Transmission Oil Temperature (+)	30
C14	Optional Indicator 1	—
C15	Check Engine Warning Lamp	440A
C16	Stop Engine Warning Lamp	440S
D1	Fuel Level (+)	47
D2	Fuel Level (-)	47G
D3	Panel Backlight Ground (-)	GND
D4	Optional Indicator 9	—
D5	J1939 (+)	1939+
D6	Satellite Gauge Illumination	Black
D7	Satellite Gauge Data	Yellow
D8	Right Turn Indicator	38K
D9	J1939 (-)	1939-
D10	Optional Seat Belt (EPA10)	—
D11	Reserved	—
D12	Trailer ABS Warning Lamp	376F1
D13	ICU System Ground (-)	GND
D14	Battery Power (+)	437
D15	Ignition Power (+)	81C
D16	Headlamp Power (+)	81C

Table 2, ICU3 Connector-2 Pin Assignments, Pins C1 Through D16

Fuel Level Sensor Resistance		
Gauge Reading	Sensor Resistance in Ohms	
	Acceptable Range	Nominal
Empty Stop	244.0 to 249.0	246.5
Empty	232.0 to 239.2	235.6
1/8	190.8 to 196.9	193.8
1/4	149.6 to 154.5	152.1
3/8	126.1 to 129.0	127.5
1/2	102.5 to 103.5	103.0

54.11

Specifications

Fuel Level Sensor Resistance		
Gauge Reading	Sensor Resistance in Ohms	
	Acceptable Range	Nominal
5/8	84.4 to 85.7	85.0
3/4	66.2 to 67.8	67.0
7/8	47.8 to 49.2	48.5
Full	29.4 to 30.6	30.0

Table 3, Fuel Level Sensor Resistance

Transmission Oil Temperature Sensor Resistance			
Gauge Temperature in °F	Sensor Resistance in Ohms	Gauge Temperature in °C	Sensor Resistance in Ohms
125	3318	60	2490
163	1626	80	1255
200	837	100	680
238	460	120	390
275	267	140	234
313	162	160	145
350	102	180	95

Table 4, Transmission Oil Temperature Sensor Resistance

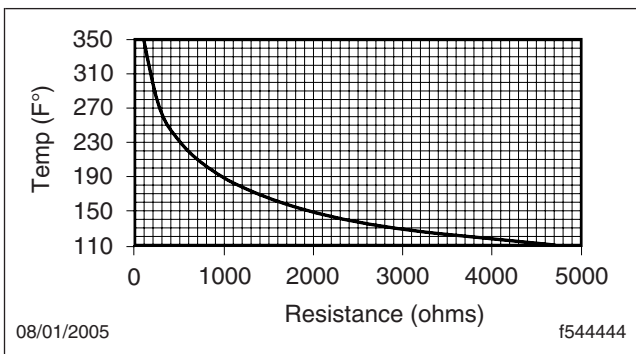

Fig. 2, Transmission Oil Temperature Sensor Resistance (°F)

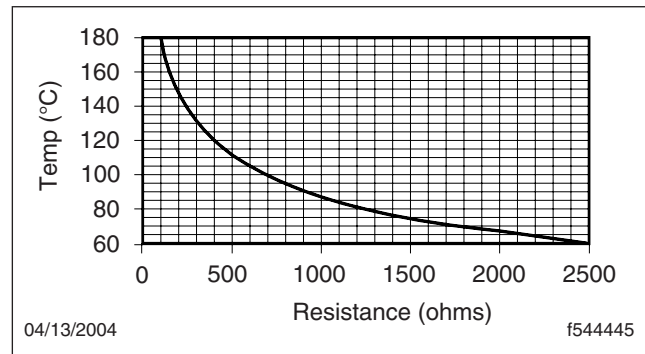

Fig. 3, Transmission Oil Temperature Sensor Resistance (°C)

Axle Oil Temperature Sensor Resistance, Standard Gauge	
Gauge Temperature	Sensor Resistance (ohms)
100°F	5933
125°F	3419
150°F	2079
175°F	1283
200°F	837
225°F	557
250°F	380
275°F	267
300°F	190

Table 5, Axle Oil Temperature Sensor Resistance, Standard Gauge

Axle Oil Temperature Sensor Resistance, Metric Gauge	
Gauge Temperature	Sensor Resistance (ohms)
30°C	8060
45°C	4465
60°C	2490
75°C	1503
90°C	915
105°C	595
120°C	390
135°C	267
150°C	185

Table 6, Axle Oil Temperature Sensor Resistance, Metric Gauge

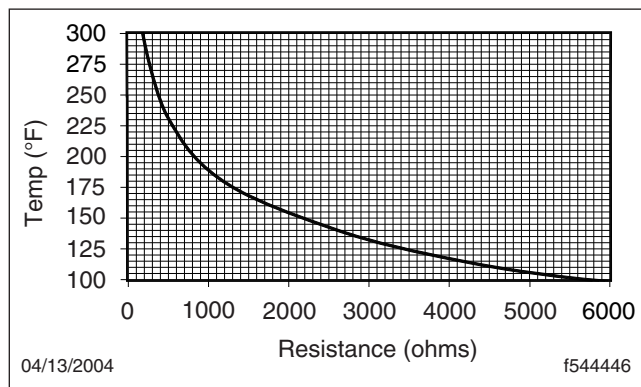

Fig. 4, Axle Oil Temperature Sensor Resistance (°F)

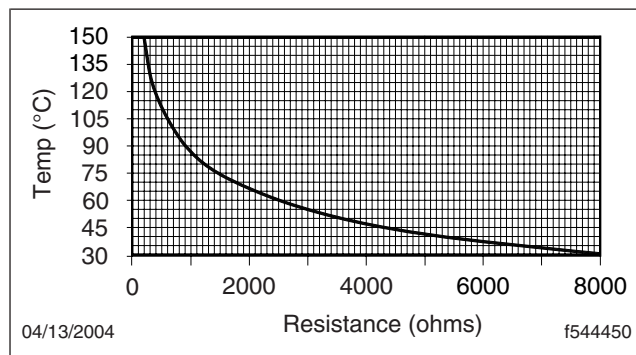

Fig. 5, Axle Oil Temperature Sensor Resistance (°C)

DEF Level Sensor Resistance Measurement				
Engine Type	Detroit	Cummins		
Part Number	04-27881-000 A04-27943-000 A04-27943-001 04-30774-000 04-30798-000	A04-27445-000	A04-27942-000	04-30774-001 04-30798-001
Test at Sensor Connector Pins NOTE: Pins are numbered left to right.	1 and 2	1 and 4	1 and 4	1 and 2
Resistance: Float at Top of Travel	~19800Ω	~68Ω	~68Ω	~68Ω
Resistance: Float at Center of Travel	~2035Ω	~730Ω	~743Ω	~742Ω

Specifications

DEF Level Sensor Resistance Measurement				
Engine Type	Detroit	Cummins		
Resistance: Float at Bottom of Travel	~240Ω	~4812Ω	~4809Ω	~4732Ω

Table 7, DEF Level Sensor Resistance Measurement

NOTE: Fig. 6 and Fig. 7 are for reference only and are not exact measurements.

1. Press the mode/reset button until the display shows SEt UP.
2. Hold the button until the display makes a beep and the word service appears. Depending on the options programmed, some other word may also appear.
3. Hold the button until the display shows rESEt.
4. Press the button once quickly so that EE is also displayed. This is the rESEt EE screen.
5. Hold the button until donE is displayed.

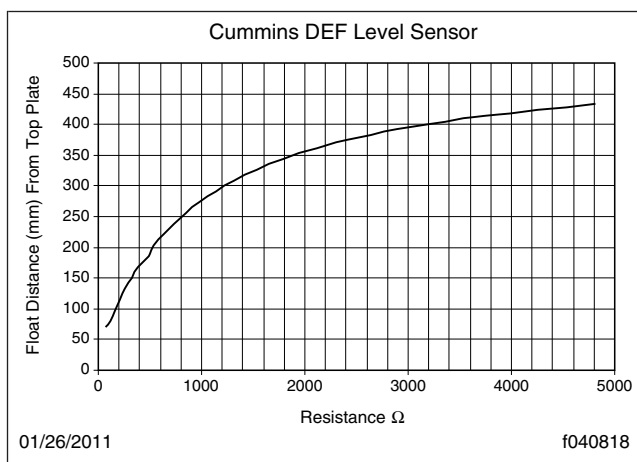

Fig. 6, Cummins DEF Level Sensor Resistance

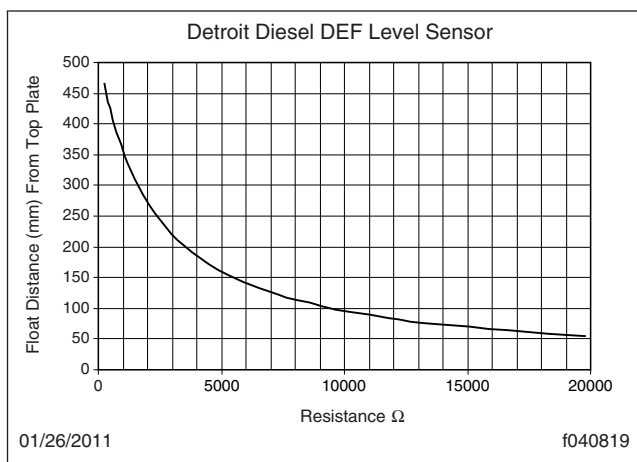

Fig. 7, DDC DEF Level Sensor Resistance

rESEt EE Procedure

To reset the EE memory in the ICU3, perform the following procedure. This will reset the memory to "forget" all the devices that have been learned.

Mode/Reset Switch Functions

Use the following flow charts to cycle through the Mode/Reset switch functions and screens.

See [Fig. 1](#), [Fig. 2](#), [Fig. 3](#), [Fig. 4](#), [Fig. 5](#), [Fig. 6](#), and [Fig. 7](#).

Mode/Reset Switch Functions

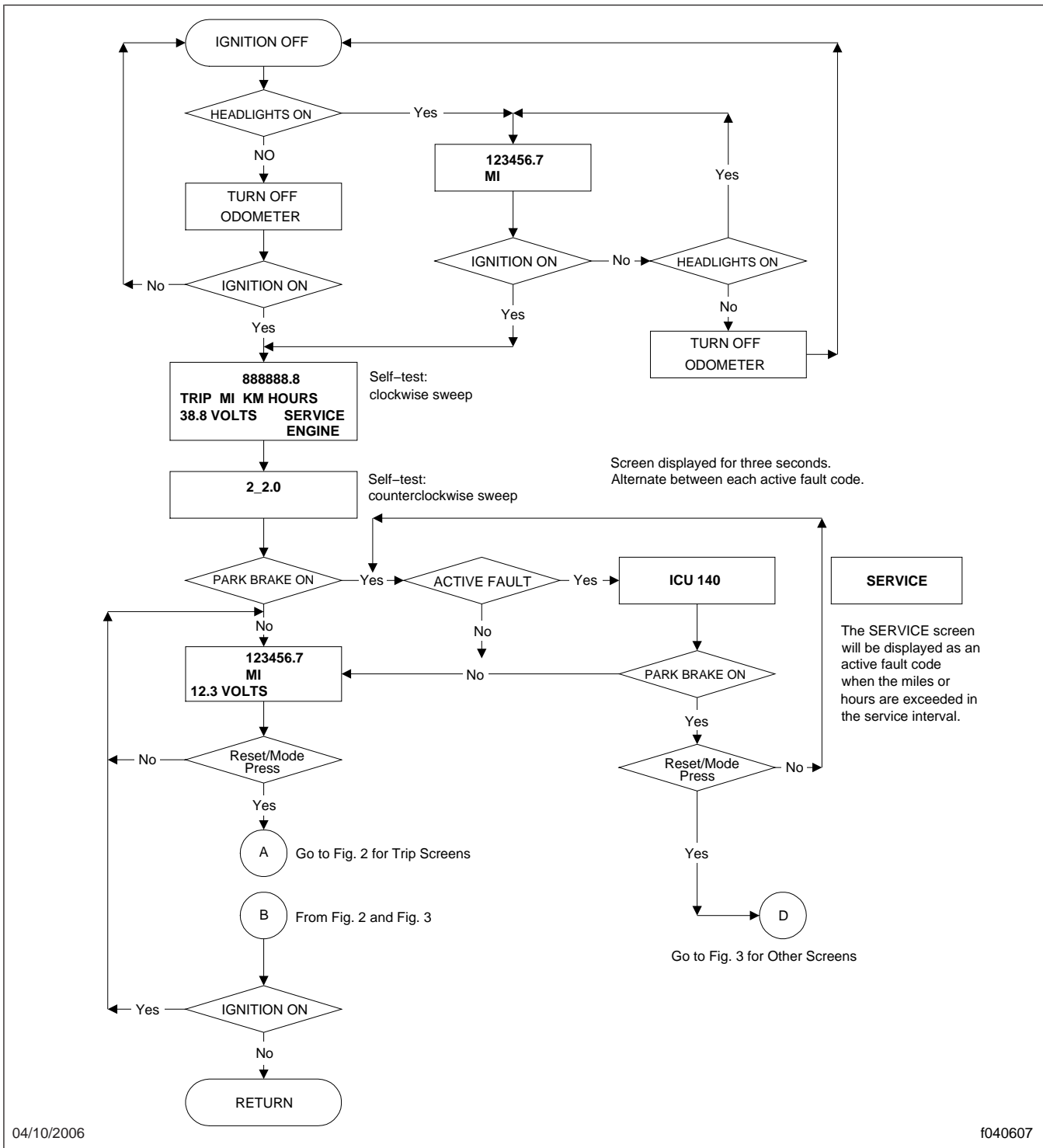

Fig. 1, Mode/Reset Switch Start Sequence

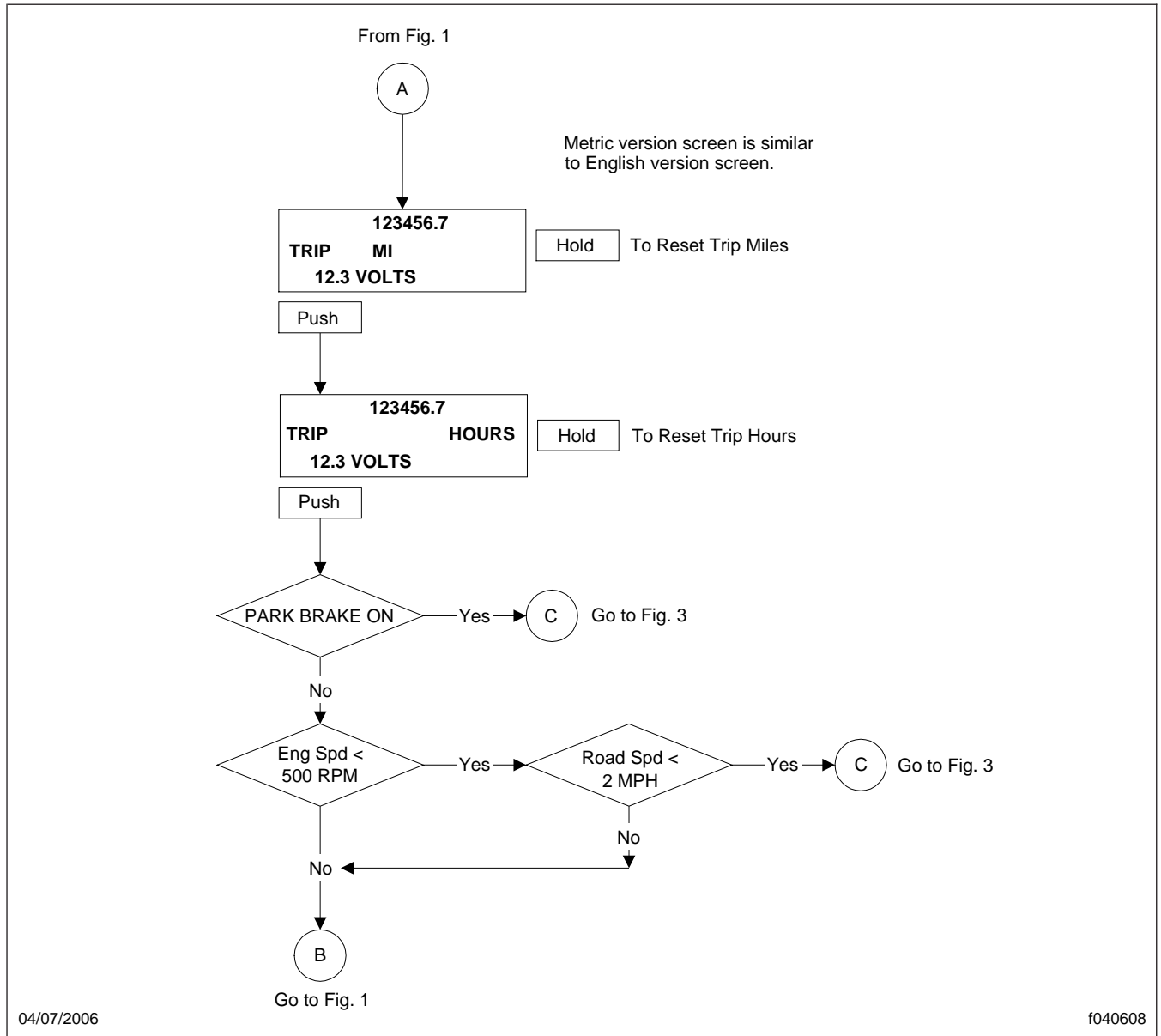

Fig. 2, Mode/Reset Switch Trip Screens

Mode/Reset Switch Functions

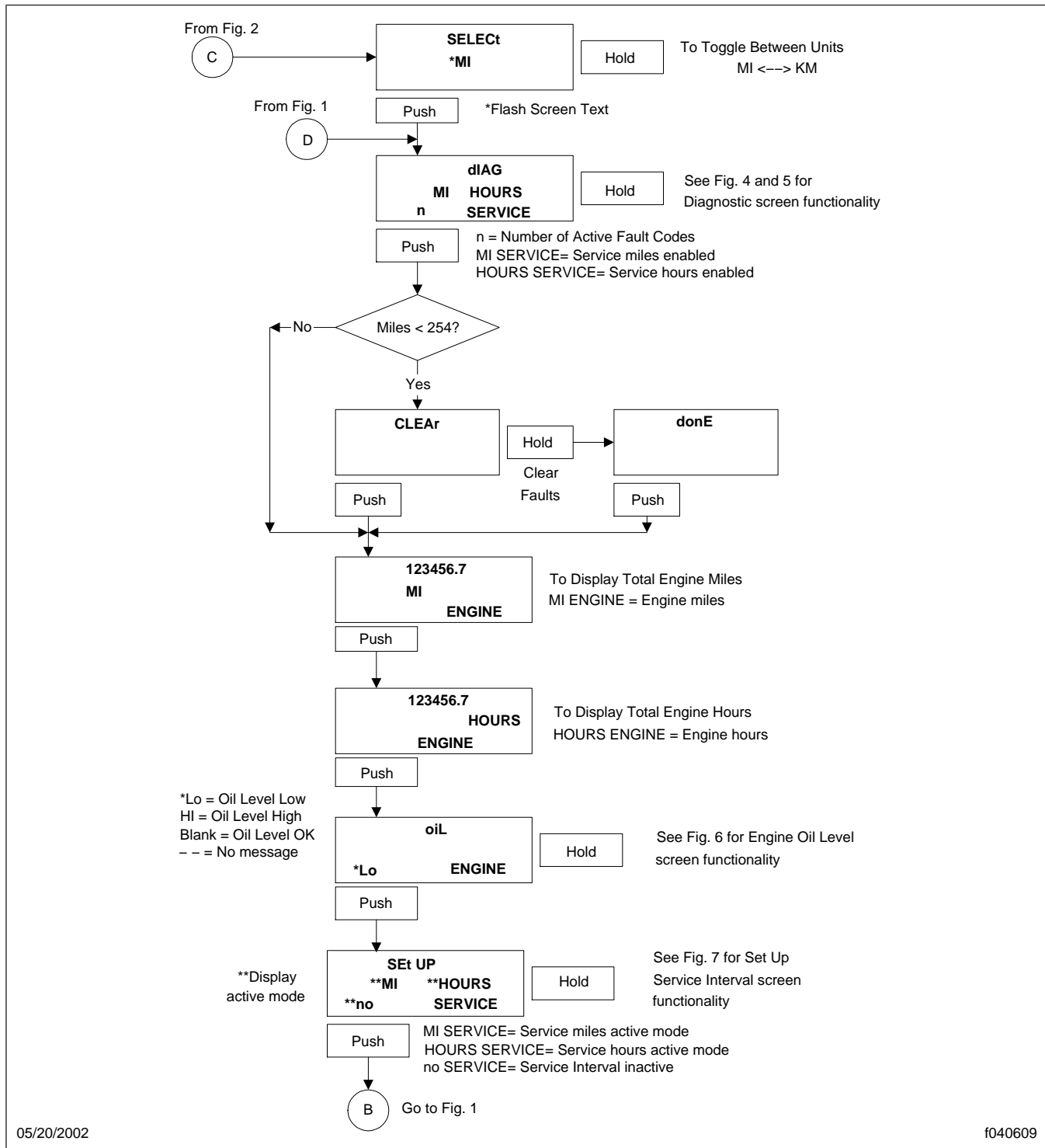

Fig. 3, Mode/Reset Switch Engine Miles and Service Screens

Mode/Reset Switch Functions

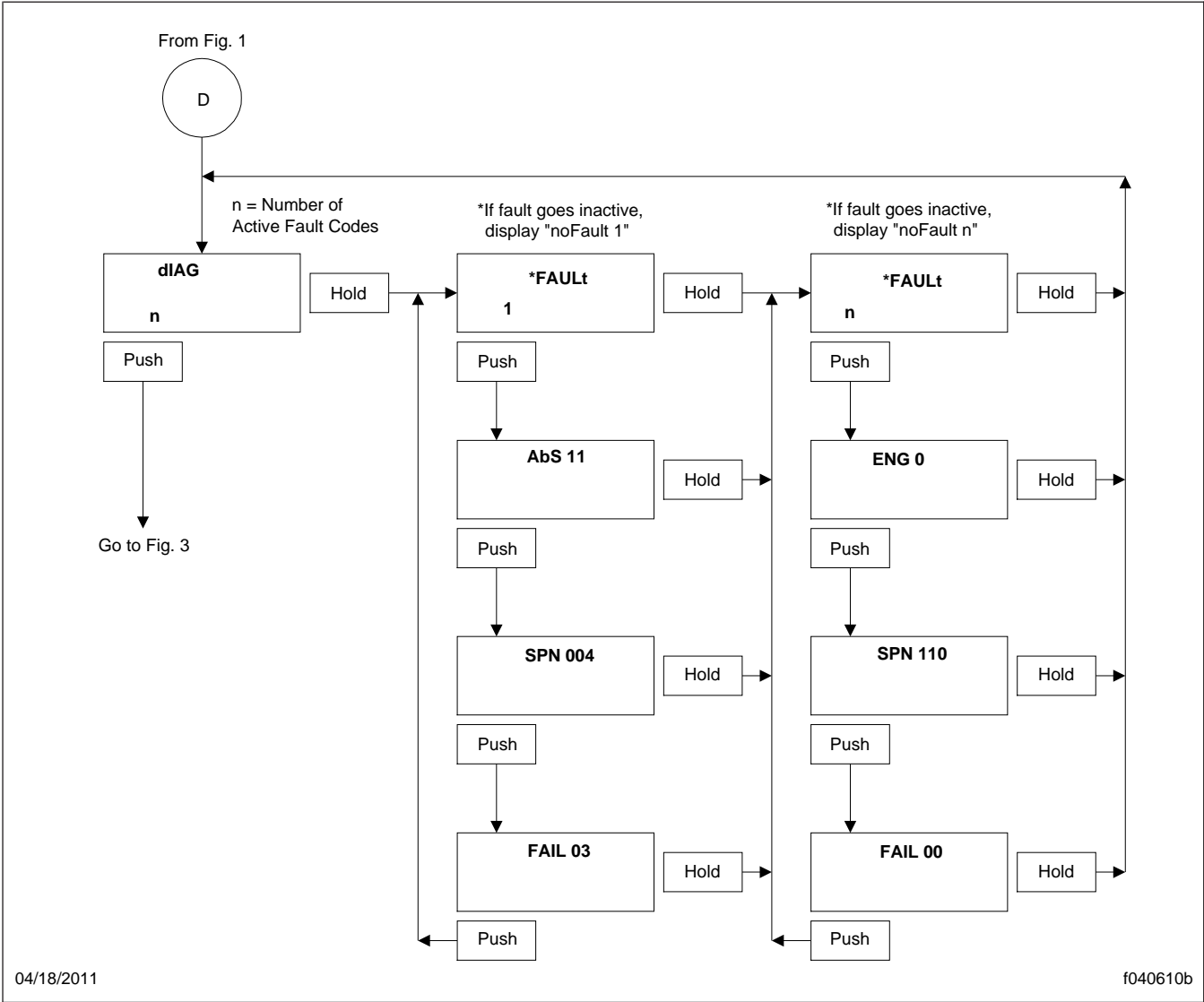

Fig. 4, Mode/Reset Switch Fault Screens

Mode/Reset Switch Functions

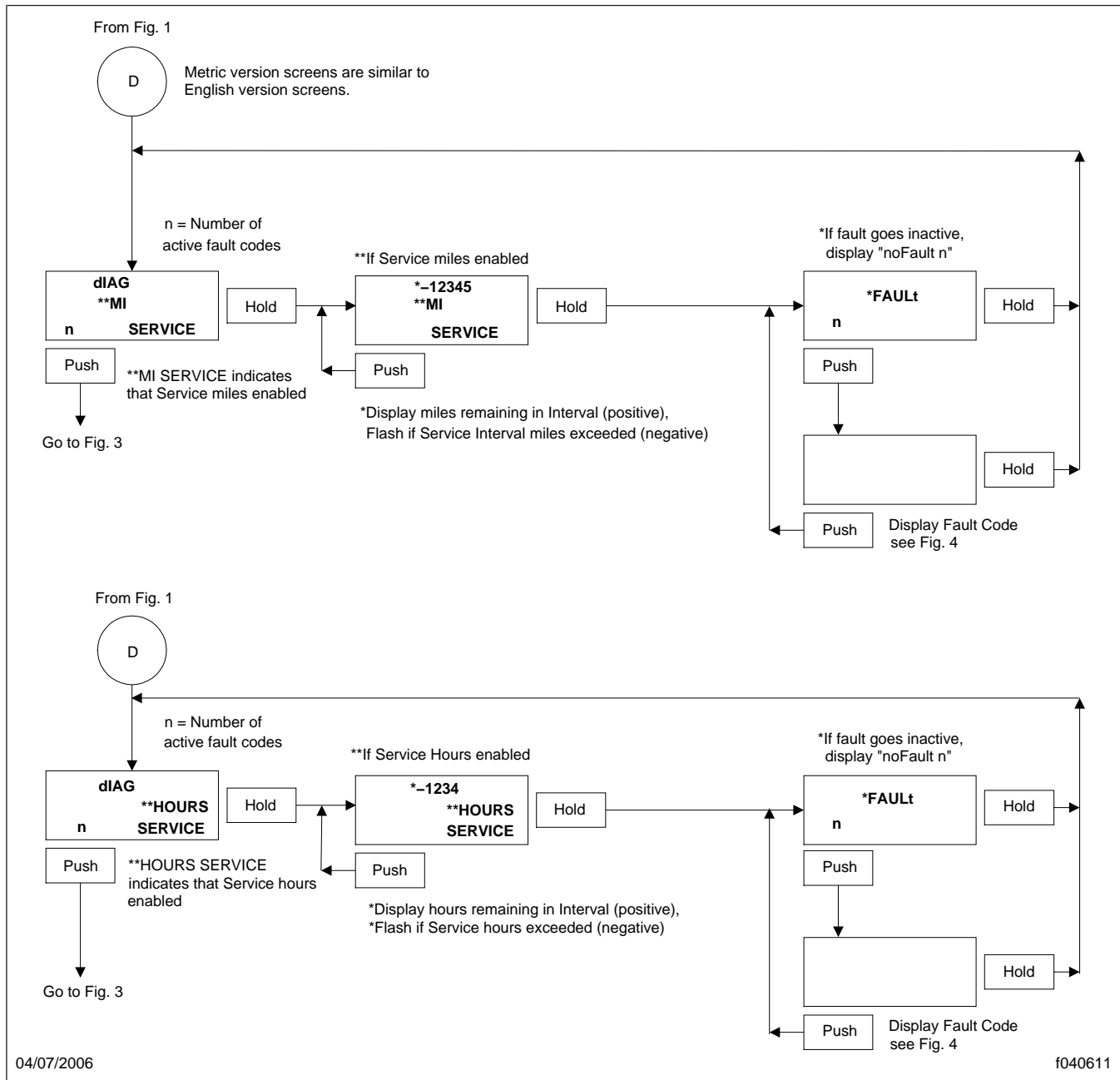
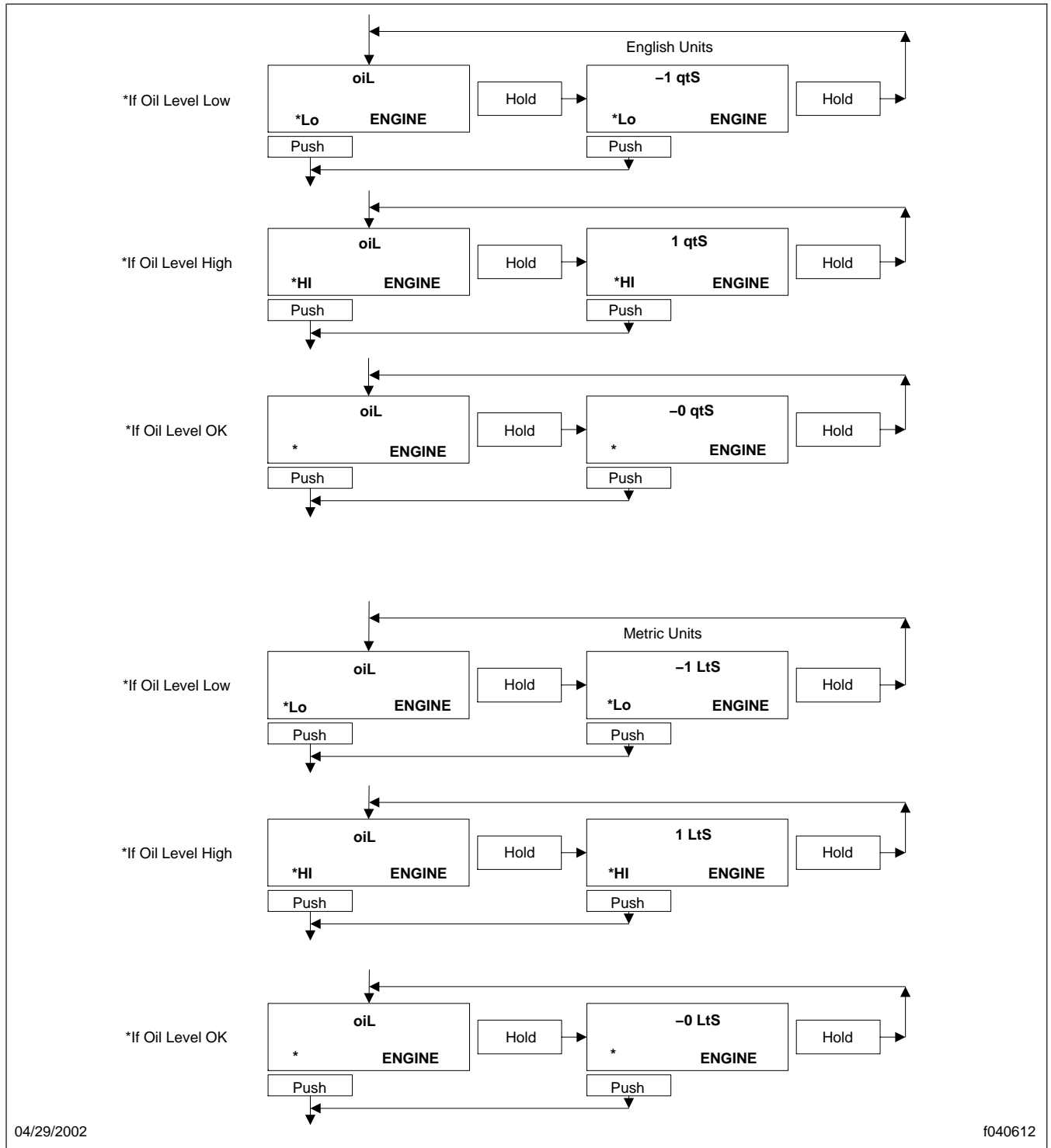

Fig. 5, Mode/Reset Switch Service Screens

Mode/Reset Switch Functions



04/29/2002

f040612

Fig. 6, Mode/Reset Switch Oil Level Screens

Mode/Reset Switch Functions

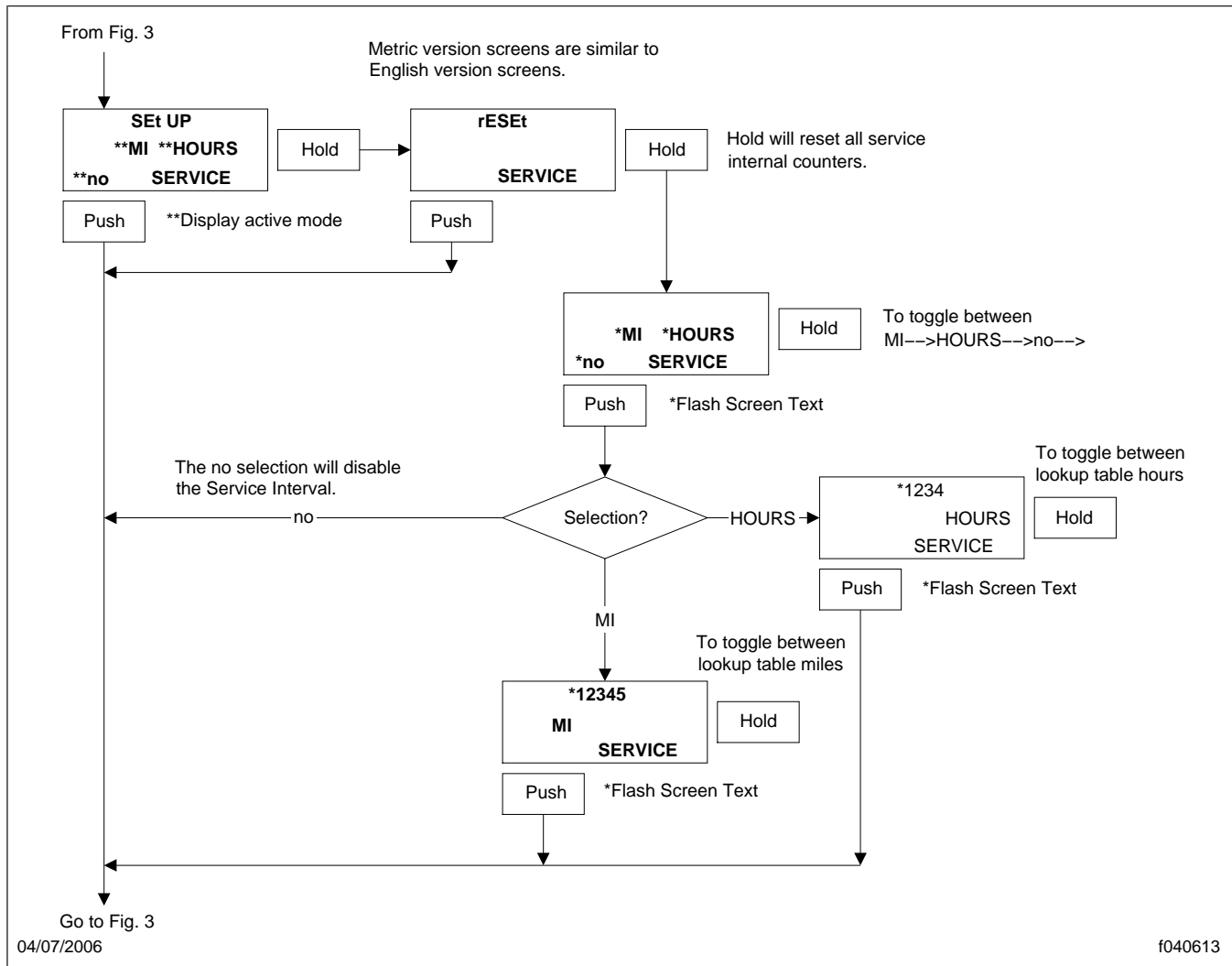

Fig. 7, Mode/Reset Switch Reset and Toggle Screens