

12" TO 30" BOLT DOWN STYLE STEEL STAND FOR GENERATOR

SCOPE OF WORK:

PROVIDE STRUCTURAL DRAWING FOR A STEEL STAND TO RESIST WIND LOADING PER FBC-23

STRUCTURAL NOTES:

THE WORK SPECIFIED HEREIN HAS BEEN DESIGNED & ALL WORK SHALL BE IN ACCORDANCE WITH THE STRUCTURAL PROVISIONS OF THE FLORIDA BUILDING CODE 2023.

ASCE 7-22 CHAPTER 29 SECTION 3 SOLID FREESTANDING WALLS & SOLID SIGNS:

V=186 MPH MAX. EXPOSURE 'C'

H= 5.41', S= 5.41', B= 4.08'

KD=0.85, KZT=1.0, KZ=0.95

QH = 0.00256*Kh*Kzt*Ke*V² = 45.23 PSF

P = QH G(CF), G = 0.85, CF= 1.50

DESIGN PRESSURE = +/- 48.98 PSF (ASD)

- DIMENSIONS AND WEIGHT OF GENERATORS SHALL CONFORM TO SPECIFICATIONS STATED HEREIN. OTHERWISE SPECIFIC EVALUATION SHALL BE PERFORMED.
- UNITS MUST BE CENTERED ON PAD WITH OPPOSITE SIDES HAVING EQUAL CLEARANCE, A MINIMUM DISTANCE FROM UNIT TO PAD EDGE IS SPECIFIED.
- THE AREA UNDER CONCRETE SLAB ON GROUND SHALL HAVE ALL VEGETATION, STUMPS, ROOTS, AND FOREIGN MATERIALS REMOVED PRIOR TO INSTALLATION ON COMPACTED SOIL AS VERIFIED BY OTHERS.
- ELECTRICAL GROUND, WHEN REQUIRED, TO BE DESIGNED & INSTALLED BY OTHERS. ALL MECHANICAL SPECIFICATIONS (CLEAR SPACE, TONNAGE, ETC.) SHALL BE AS PER MANUFACTURER RECOMMENDATIONS AND ARE THE EXPRESS RESPONSIBILITY OF THE CONTRACTOR
- HEIGHT OF THE GENERATOR STAND/ SLAB (ASSEMBLY PROVIDED BY CLIENT).
- THIS IS A GENERIC ENGINEERING, THIS ENGINEERING FIRM HAS NEVER BEEN IN THE SITE JOB.

THESE PLANS CERTIFY THE STRUCTURAL ADEQUACY OF THE PROPOSED SYSTEM IN ACCORDANCE WITH THE STRUCTURAL REQUIREMENTS OF THE BUILDING CODE ONLY.

LIST OF APPLICABLE GENERAC GENERATORS:

- G007171-0, G007172-0 (10 kW)
- G007173-0, G007174-0, G007175-0 (13 kW)
- G007176-0, G007177-0, G007178-0 (16 kW)
- G007042-2, G007043-2 (22 kW)
- G007038-3, G007039-3 (20 kW)
- G007042-3, G007043-3 (22 kW)
- G007209-0, G007210-0 (24kW)
- G007290-0, G007291-0 (26 kW)

LIST OF APPLICABLE KHOLER GENERATORS:

- 14RESA (14 kW)
- 14RCA (14 kW)
- 14RESA (14 kW)
- 14RCA (18 kW)
- 20RESCL (20 kW)
- 20RESC (20 kW)
- 20RCA (20 kW)

GENERAL NOTES:

- CONSTRUCTION METHODS PROCEDURES, AND SEQUENCES ARE THE CONTRACTOR'S RESPONSIBILITY AND THE CONTRACTOR IS TO TAKE ALL THE NECESSARY MEANS TO MAINTAIN AND PROTECT THE STRUCTURAL INTEGRITY OF ALL CONSTRUCTION AT ALL STAGES.
- SHOULD ANY SPECIFIC CONDITION DIFFER FROM THAT SPECIFIED HEREIN, OR STANDARD FIELD CONDITIONS, ADDITIONAL SPECIFIC ENGINEERING MAY BE REQUIRED AS DETERMINED BY THE BUILDING INSPECTOR AND PERMITTING CONTRACTOR.
- USE MANUFACTURER'S CERTIFIED DRAWINGS AND SPECIFICATIONS FOR ADDITIONAL INFORMATION NOT SHOWN IN THESE PLANS.
- DIMENSIONS ARE SHOWN TO ILLUSTRATE DESIGN FORCES AND OTHER DESIGN CRITERIA. THEY MAY VARY SLIGHTLY, BUT SHALL REMAIN IN CONFORMANCE WITH THE LIMITATIONS OF THIS PLAN. THE CONTRACTOR IS TO VERIFY ALL FIELD DIMENSIONS PRIOR TO INSTALLATION, AND VERIFY THAT PROPOSED DIMENSIONS AND FIELD CONDITIONS AGREE WITH THIS PROPOSED PLAN. THESE DRAWINGS ARE NOT INTENDED TO BE USED AS FABRICATION OR SHOP DRAWINGS.
- ALL STRUCTURAL MEMBERS AS SHOWN HAVE BEEN DESIGNED TO CARRY IN PLACE DESIGN LOADS ONLY, THE CONTRACTORS SHALL BE RESPONSIBLE FOR THE SUPPORT OF ANY ADDITIONAL LOADS AND FORCES IMPOSED DURING MANUFACTURING, TRUCKING, ERECTING, AND HANDLING.
- ALL THE CONTRACTOR'S PROPOSED SUBSTITUTIONS SHALL BE APPROVED BY THE ENGINEER, BY LETTER, PRIOR TO ANY PERMANENT WORK AND PRIOR TO THE AWARD OF THE CONTRACT.
- ENGINEER SEAL AFFIXED HERETO VALIDATES STRUCTURAL DESIGN AS SHOWN ONLY. USE OF THIS SPECIFICATION BY CONTRACTOR, et. al. INDEMNIFIES & SAVES HARMLESS THIS ENGINEER

FOR ALL COSTS & DAMAGES INCLUDING LEGAL FEES & APPELLATE FEES RESULTING FROM MATERIAL FABRICATION, SYSTEM ERECTION, & CONSTRUCTION PRACTICES BEYOND THAT WHICH IS CALLED FOR BY LOCAL, STATE, & FEDERAL CODES & FROM DEVIATIONS OF THIS PLAN. EXCEPT AS EXPRESSLY PROVIDED IN HEREIN, NO ADDITIONAL CERTIFICATIONS OR AFFIRMATIONS ARE INTENDED.

- THIS DOCUMENT CONTAINS INFORMATION RELEVANT TO THE NECESSARY STRUCTURAL REQUIREMENTS OF THE SYSTEM INSTALLATION. COMPONENTS AND FASTENERS NOT REFERENCED WHICH ARE PART OF THE INTERNAL FABRICATION OF THE SPECIFIED SYSTEMS SHALL BE PER MANUFACTURER PUBLISHED SPECIFICATIONS.
- THIS ENGINEER SHALL NOT BE HELD RESPONSIBLE OR LIABLE IN ANY WAY FOR ERRONEOUS OR INACCURATE DATA OR MEASUREMENTS. THIS ENGINEER SHALL BE NOTIFIED AND GIVEN AN OPPORTUNITY TO RE-EVALUATE OUR WORK UPON DISCOVERY OF ANY INACCURATE INFORMATION UPON DISCOVERY OF ANY NON-MATCHING FIELD CONDITIONS AND FABRICATION AND INSTALLATION OF MATERIALS.
- OMISSIONS/CONFLICTS: IN CASE OF OMISSIONS AND CONFLICTS BETWEEN PLANS, SPECIFICATIONS AND SITE CONDITIONS THE ENGINEER SHALL BE NOTIFIED BEFORE PROCEEDING WITH WORK.
- THE CONTRACTOR IS RESPONSIBLE TO INSULATE DISSIMILAR METALS TO PREVENT ELECTROLYSIS.

STEEL REINFORCEMENT (AS APPLICABLE):

- ALL REINFORCEMENT SHALL BE GRADE 60 (U.O.N.), FREE FROM OIL, LOOSE SCALE AND LOOSE RUST AND BENT, LAPPED, PLACED, SUPPORTED AND FASTENED ACCORDING TO THE "ACI DETAILING MANUAL" (SP-66) AND THE ACI 318. ALL STEEL SHALL BE SECURELY HELD IN PLACE DURING POURING OF CONCRETE.

STRUCTURAL STEEL:

- ALL STRUCTURAL STEEL COMPONENTS SHALL BE FABRICATED AND ERECTED ACCORDING TO THE GOVERNING BUILDING CODE AND MATERIAL STANDARDS REFERENCED ON THIS SHEET.
- ANGLES, W SHAPE, CHANNELS, PLATES, PIPES, AND STRUCTURAL TEES: $f_y = 36$ KSI CONFORM TO ASTM A36. STRUCTURAL TUBING: $f_y = 46$ KSI CONFORM TO ASTM A 500.
- STRUCTURAL TUBING SHALL CONFORM TO ASTM A-500 GRADE B, $F_y=46$ KSI.
- WELDING MUST BE DONE BY AN AWS CERTIFIED WELDER OR SHALL CONFORM TO AISC STEEL CONSTRUCTION MANUAL AS INSPECTED AND VERIFIED BY OTHERS. MIN. WELD IS 1/8" FULL PERIMETER FILLET WELD (U.N.O.). WELD ELECTRODES SHALL BE E70XX FOR CARBON STEEL. FOR STAINLESS STEEL, WELD ELECTRODES SHALL FOLLOW ASTM E330 AND AMERICAN WELDING SOCIETY SPECIFICATION AWS A5.4. ALL WELDS NOT OTHERWISE IDENTIFIED SHALL BE CONTINUOUS.
- ALL STEEL EXPOSED TO WEATHER SHALL BE HOT DIPPED GALVANIZED IN ACCORDANCE WITH ASTM A123, PAINTED OR POWDERCOATED IN ACCORDANCE WITH ASTM D-523/ D-3359.
- WELDS SHOWN ON THE DRAWINGS ARE MINIMUM DESIGN REQUIREMENTS.

CONCRETE(AS APPLICABLE):

- SHALL BE PER AN APPROVED MIX DESIGN PROPORTIONED TO ACHIEVE A STRENGTH AT 28 DAYS LISTED BELOW:
 - 3000 PSI MINIMUM COMPRESSIVE STRENGTH.
 - 4000 PSI FOR FOUNDATIONS
 - 5000 PSI FOR OTHER STRUCTURAL CONCRETE.
- WATER/CEMENT RATIO FOR CONCRETE OF EXTERIOR COLUMNS, BEAMS, AND ELEVATED SLABS SHALL NOT EXCEED 0.40 BY WEIGHT.
- CONCRETE SHALL BE PLACED AND CURED ACCORDING TO ACI STANDARDS AND SPECIFICATIONS.
- AGGREGATES SHALL BE CLEAN AND GRADED MAXIMUM SIZES 3/4". CONCRETE ASTM C-33 CONFORMS TO ASTM C-94.
- SLUMP SHALL BE A MINIMUM OF 3" AND MAXIMUM OF 5" CONCRETE DURING AND IMMEDIATELY AFTER DEPOSING SHALL BY THOROUGHLY COMPACTED BY MEANS OF MECHANICAL VIBRATION.

SLAB ON GROUND NOTES(AS APPLICABLE):

- ALL WORK SPECIFIED HEREIN HAS BEEN DESIGNED AND SHALL BE ALL CONCRETE TO REACH A MIN. COMPRESSIVE STRENGTH OF 3000 PSI IN 7 DAYS. CONCRETE SHALL CONTAIN MINIMUM 0.1% FIBER MESH CONTENT PER CUBIC YARD OR HAVE REINFORCEMENT AS DESCRIBED HEREIN. SURROUNDING SOIL TO BE COMPACTED TO OPTIMUM DENSITY.
- SURROUNDING SOIL TO BE COMPACTED TO 95% OPTIMUM DENSITY, 2000 PSF MIN AND SHALL BE CLASSIFIED OR VERIFIED BY OTHERS PRIOR TO CONSTRUCTION PER IBC 1806.2 AND SHALL BE SANDY GRAVEL CLASS ONLY.

SAFETY OSHA AND LABOR LAWS:

THE STRUCTURAL ENGINEER OF RECORD NEITHER POSSESS, NOR PRESUMES TO POSSESS, ANY KNOWLEDGE OR EXPERTISE CONCERNING JOBSITE EMPLOYEE SAFETY, OSHA OR LABOR LAW REQUIREMENTS FOR A CONSTRUCTION PROJECT. SAFETY AND COMPLIANCE WITH OSHA AND LABOR LAWS ARE THE ABSOLUTE RESPONSIBILITY OF THE GENERAL CONTRACTOR (GC) AND HIS CONSULTANTS TO ADDRESS THESE MATTERS. THE STRUCTURAL ENGINEER OF RECORD SPECIALIZES IN STRUCTURAL DESIGN ONLY. THE BOARD OF PROFESSIONAL REGULATION FORBIDS HIM FROM ASSUMING RESPONSIBILITY OUTSIDE HIS AREA OF EXPERTISE.

CHANGES OR SUBSTITUTIONS

- PROPOSED CHANGES OR SUBSTITUTIONS TO STRUCTURAL DETAILS OR PLANS SHALL BE SUBMITTED TO THIS ENGINEER FOR REVIEW AND APPROVAL.
- SUBMITTALS SHALL CONTAIN FULL DOCUMENTATION OF CHANGES OR SUBSTITUTIONS WITH SUPPORTING, SEALED CALCULATIONS (WHERE APPLICABLE).
- THE REVIEW OF CHANGES AND SUBSTITUTIONS, RE-ANALYSIS AND/OR REDRAFTING TO INCORPORATE CHANGES OR SUBSTITUTIONS INTO CONTRACT DOCUMENTS ARE ADDITIONAL SERVICES.
- CONSTRUCTION COST REVISIONS ARE BETWEEN THE CONTRACTOR AND OWNER AND ARE NOT REVIEWED BY THIS ENGINEER.

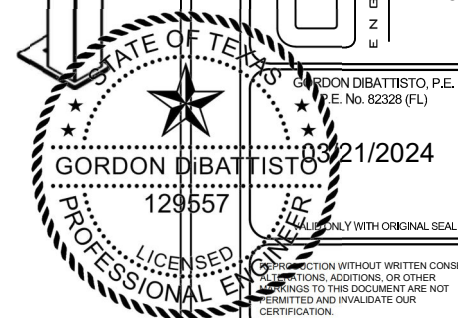
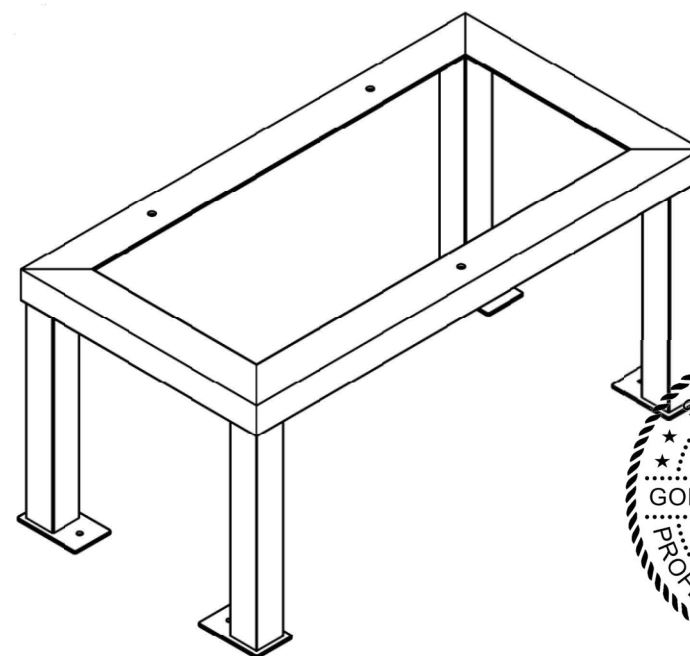

DATE	DESCRIPTION	DRWN	CHKD
04/12/23	INITIAL SET	FM	LAO
03/21/24	FBC-23	JA	LAO

GORILLA MANUFACTURING
19525 WIED ROAD, SUITE 450
SPRING, TX 77388

12" TO 30" BOLT DOWN STYLE STEEL STAND FOR GENERATOR
FLORIDA BUILDING CODE 2023

P22-2117-00.0-GORI00-01

GORILLA ENGINEERING
2801 NW 85TH CT.
FORT LAUDERDALE, FL 33309
OFFICE@GOREENGINEERING.COM
REGISTRY No. 23162

GORDON DiBATTISTO, P.E.
P.E. No. 82328 (FL)
03/21/2024
REVISIONS TO THIS DOCUMENT ARE NOT PERMITTED AND INVALIDATE OUR CERTIFICATION.

SHEET:
S0.00

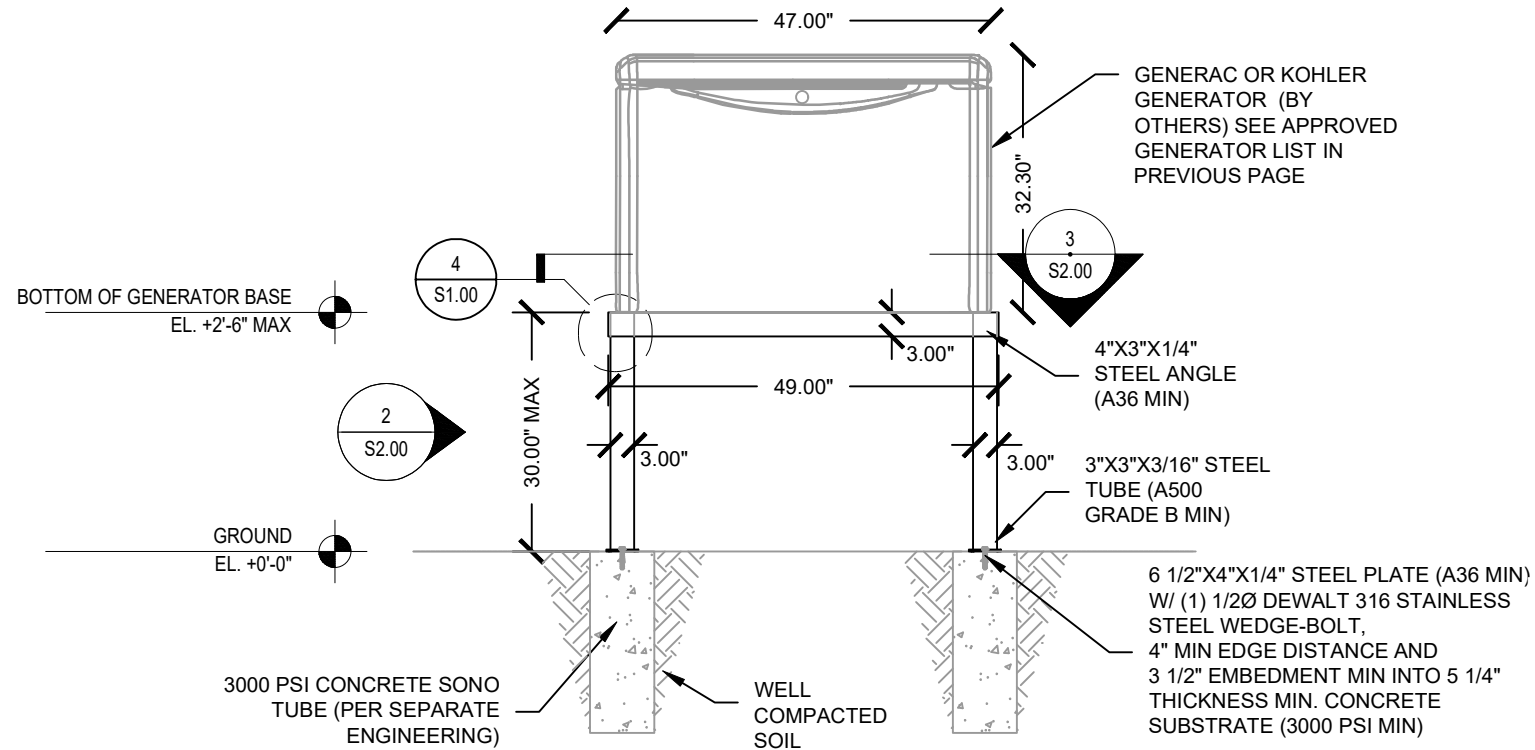

1 GENERATOR
S2.00 SCALE: 1/2" = 1' FRONT VIEW

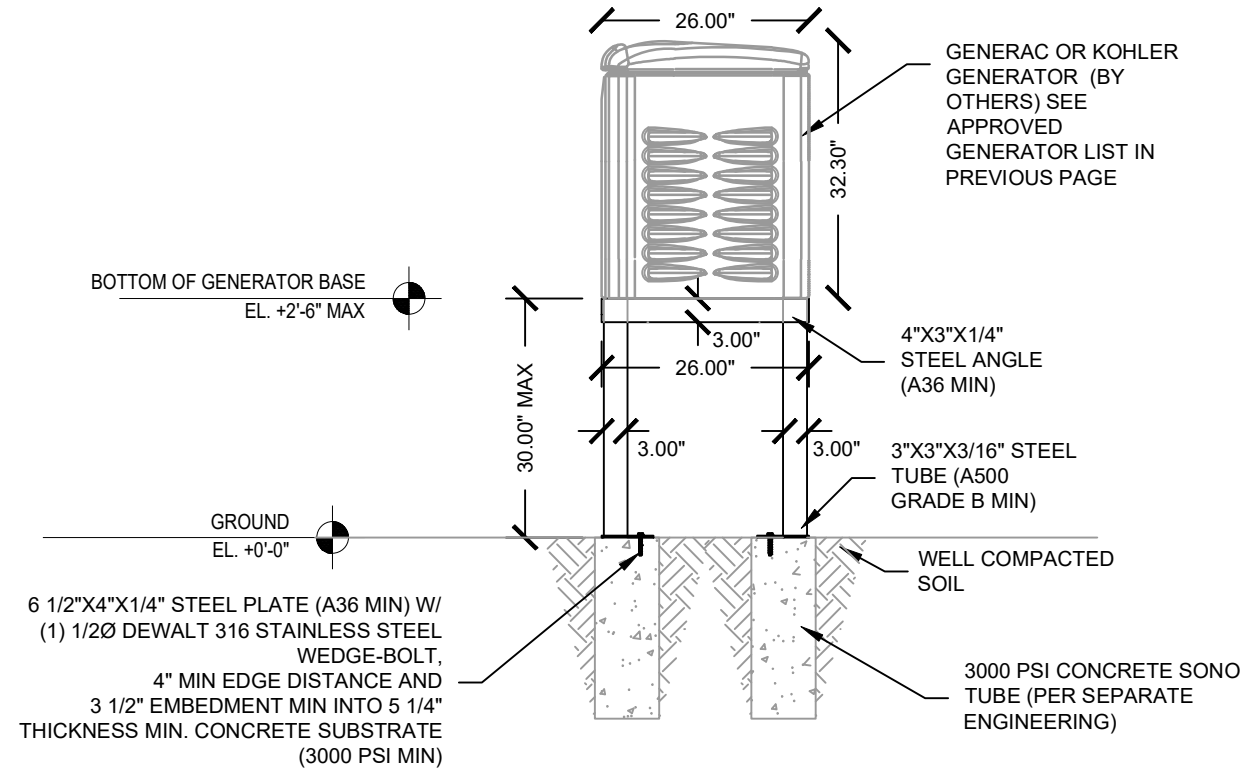

2 GENERATOR
S2.00 SCALE: 1/2" = 1'-0" SIDE VIEW

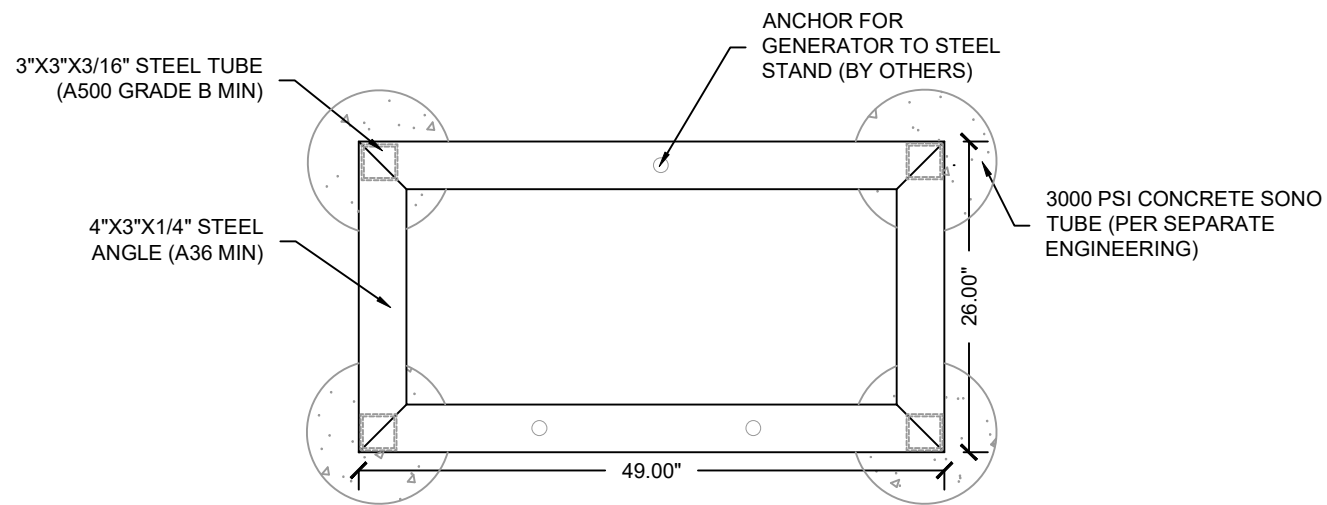

3 ANCHOR LOCATION
S2.00 SCALE: 3/4" = 1' PLAN VIEW

DATE	DESCRIPTION	DRWN	CHKD
04/12/23	INITIAL SET	FM	LAO
03/21/24	FBC-23	JA	LAO

GORILLA MANUFACTURING

19525 WIED ROAD, SUITE 450
SPRING, TX 77388

12" TO 30" BOLT DOWN STYLE STEEL STAND FOR GENERATOR

FLORIDA BUILDING CODE 2023

P22-2117-00.0-GORI00-01

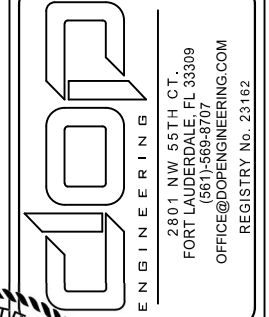

2801 NW 56TH CT
FORT LAUDERDALE, FL 33309
(561) 580-8707
OFFICE@DOPENGINEERING.COM
REGISTRY No. 23162



SHEET:

S2.00