

# Hydraulic Toe Jack

**Model FTJ**

Operation Manual  
Capacity Up to 10T



Doc No.: f2.0/HTJ/R0



## Description & Data

The FTJ Hydraulic Toe Jacks are designed for lifting and moving heavy machinery or parts within a factory. The low ground clearance allows for accessing cramped lifting points and does not require any power source. The in-built hand pump may be used to lift the equipment to desired height for levelling or transportation. The detachable handle for easy storage and transportation. The jack has an in-built pressure relief/ safety valve to prevent overloading. The jack body is made from high strength Iron casting with aluminium hand pump.

Size	FTJ	
Capacity	Metric Tonne	5T/ 10T
Lifting Height	Mm	200/ 250
Oil Reservoir		In-built
Handle Length	Mm	450
Weight	Kg	25/ 35
Operation		Hand Pump
Toe Height	Mm	25

## Dimension Data

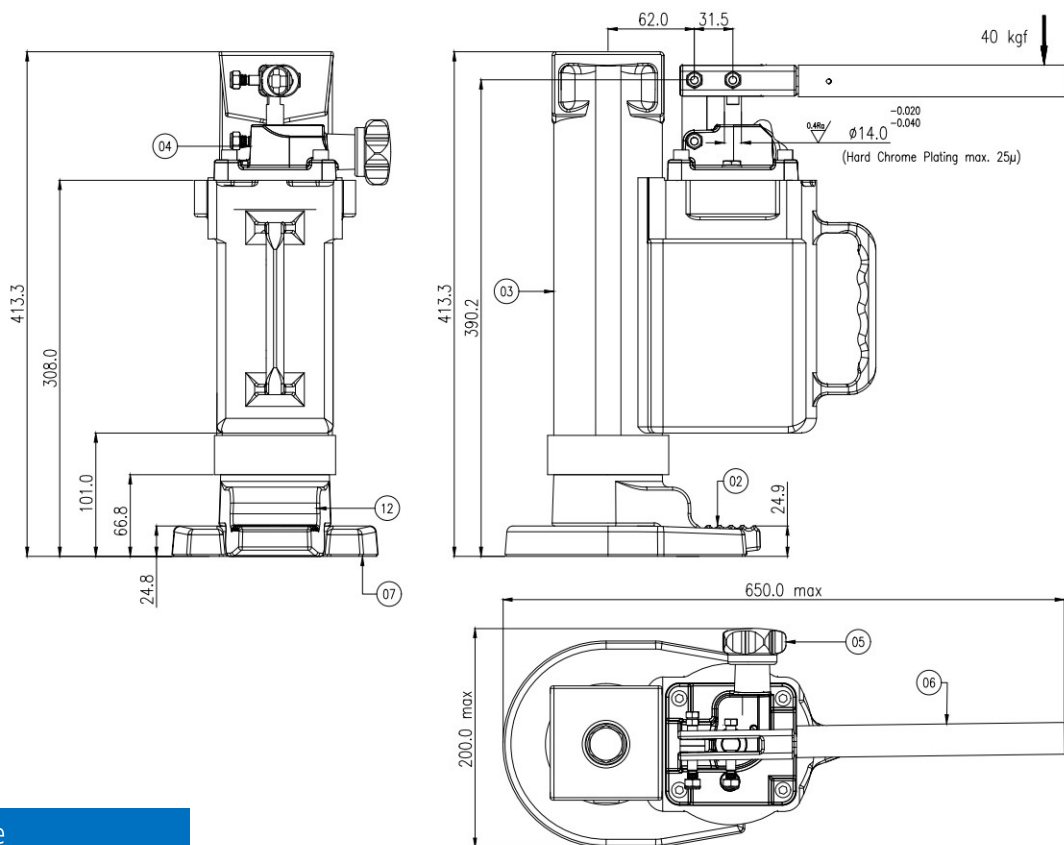

## Ordering Code

**FTJ - 5T - 1x**

1x = Version Code

5T = Max Lifting Capacity 5T  
10T = Max Lifting Capacity 10T

FTJ = FLUIDIK Hydraulic Toe Jack