

TexasCPDLabor_training

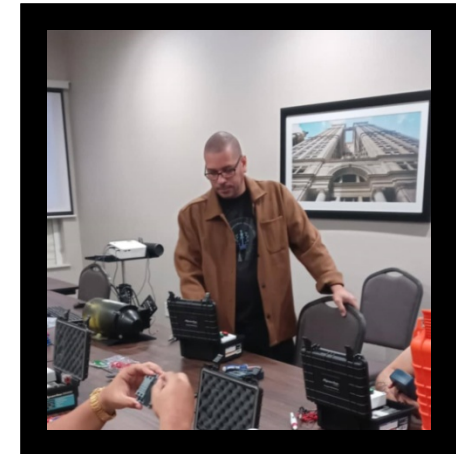

Example of troubleshooting PLC #1 INPUT CARD

This example demonstrates troubleshooting a PLC input using the software simulation program. The exercise was not completed to avoid compromising the results and damaging the software. You can purchase it at (<https://bin95.com/>); they hold the rights.



Interactive Work Order

Koldwater Technologies, LLC - Manufacturing Division
Maintenance Work Order

Date: 11 23 2025
 Time: 11:25:15 AM
 Technician Name: xxv
 Location: Part Sorter
 Operator's Trouble Report:
 Cylinder 3 will not retract. Same as before. We have already checked the solenoid. It is good.

Repair Status

- Repairs Completed - See Repair Report
- Parts Ordered - See Repair Report
- Repairs Incomplete - See Repair Report
- Unable to Determine Problem - See Repair Report

Technician's Repair Report:

Close Work Order

Power ■

Run	0	1	2	3	4	5	6	7
Run	0	1	2	3	4	5	6	7
Fail	0	1	2	3	4	5	6	7
CPU Fault	0	1	2	3	4	5	6	7

PLC Power Supply

Power is ON

Click here to open modules for testing

Plastic Wireway

Click to Open

Click to Open

Click to Open

Click to Open

Start

Stop

DIGIMETER

VAC VDC OHM

COM

PLC's Problem 7

Technician: xxv

Work Order

Process Operation

Monitor Logic

Circuit Breakers

Fault List

Menu

<< Back

Forward >>

EXIT

11:49:25 AM

Technician's Notes

Erase Notes Copy Notes to Report

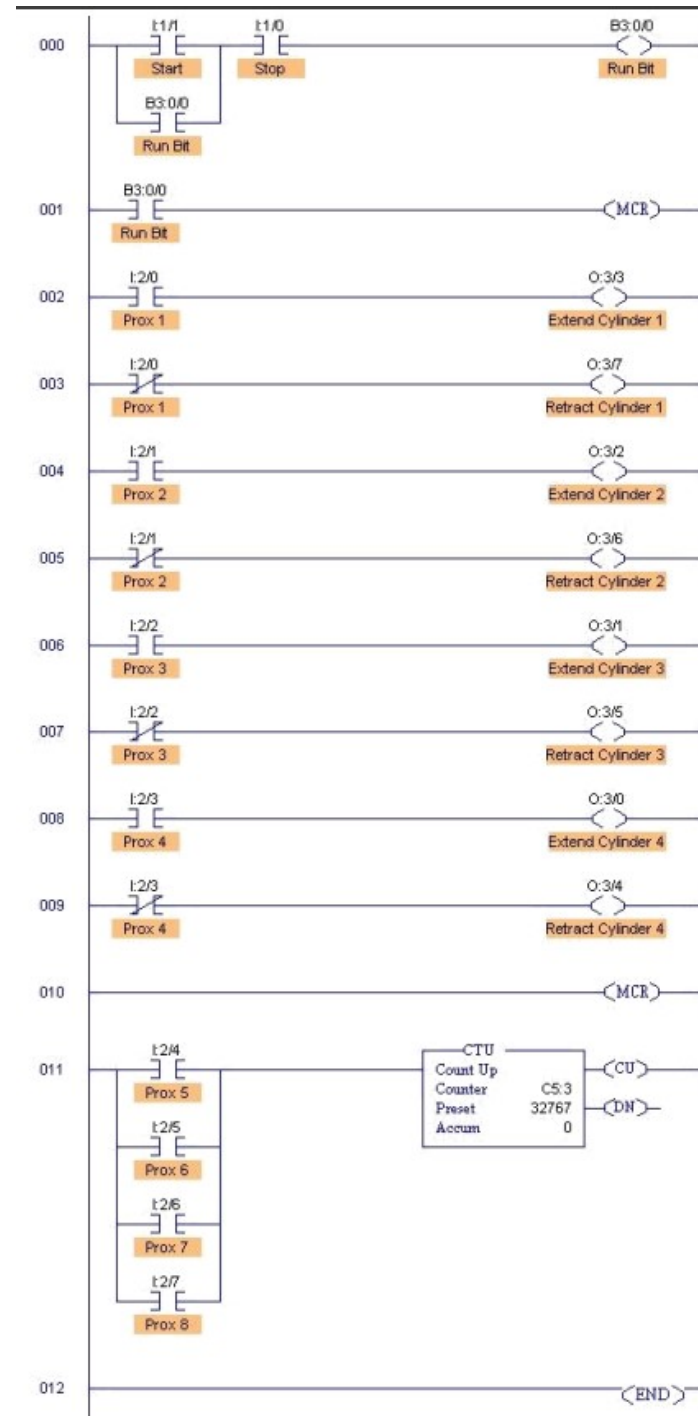

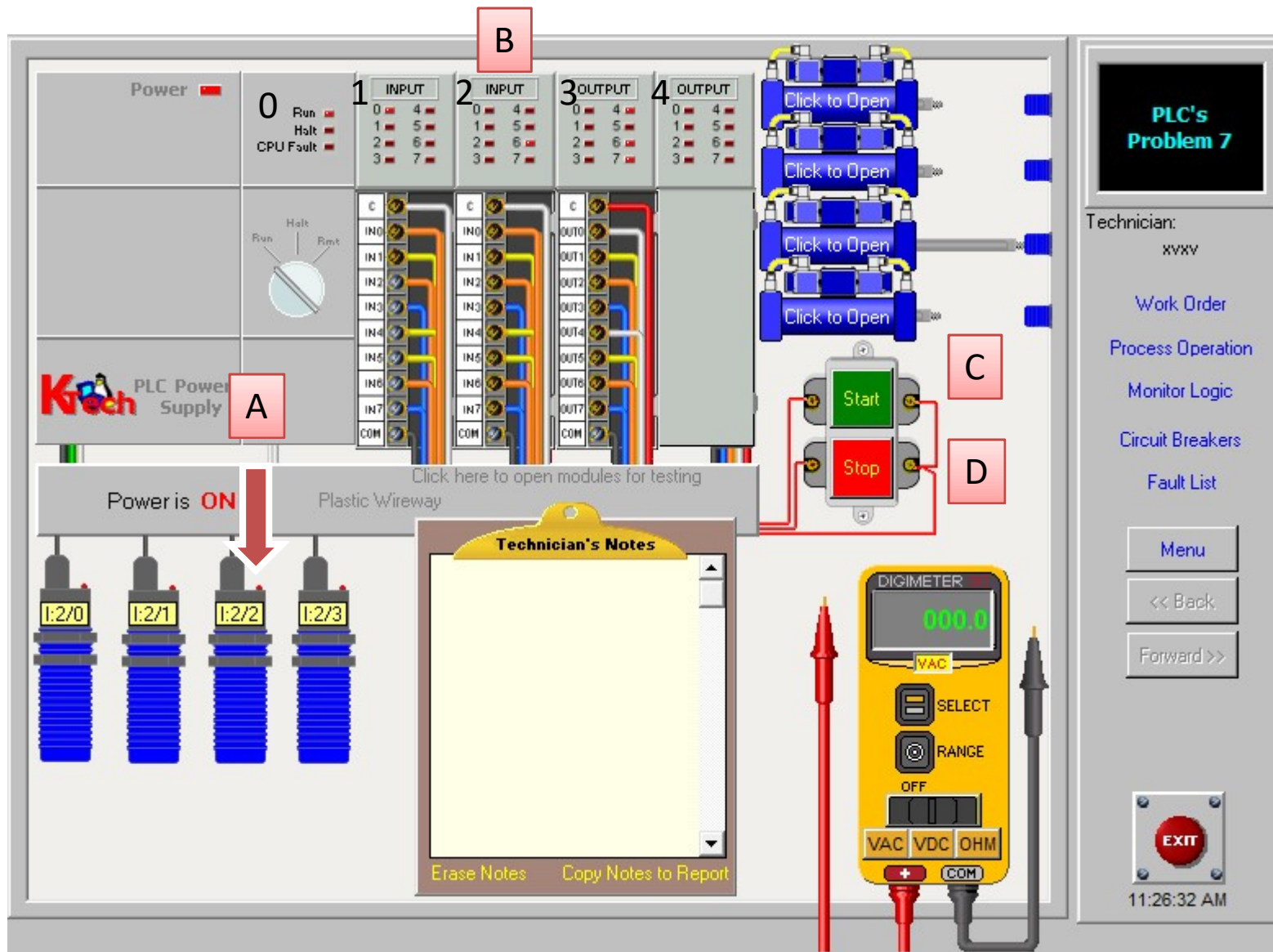

A In letter (A) we locate the sensor that actuates the piston by looking at the sensor label.

B the input card where the sensor that is actuating the piston is connected.

C It is the machine's power button located at (I:1/1).

D It is the machine's power off button located at (I:1/0) and its light is on because it is (NC).

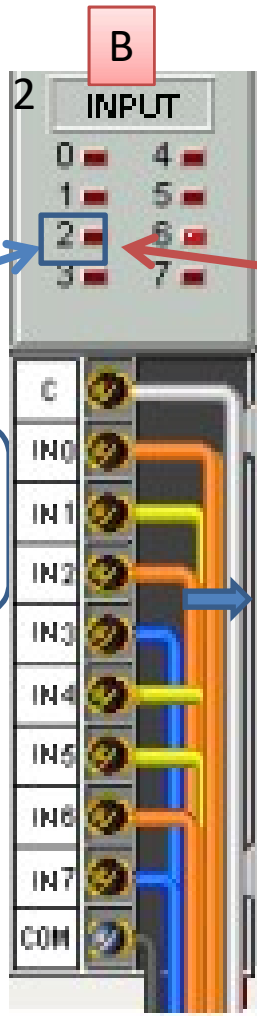
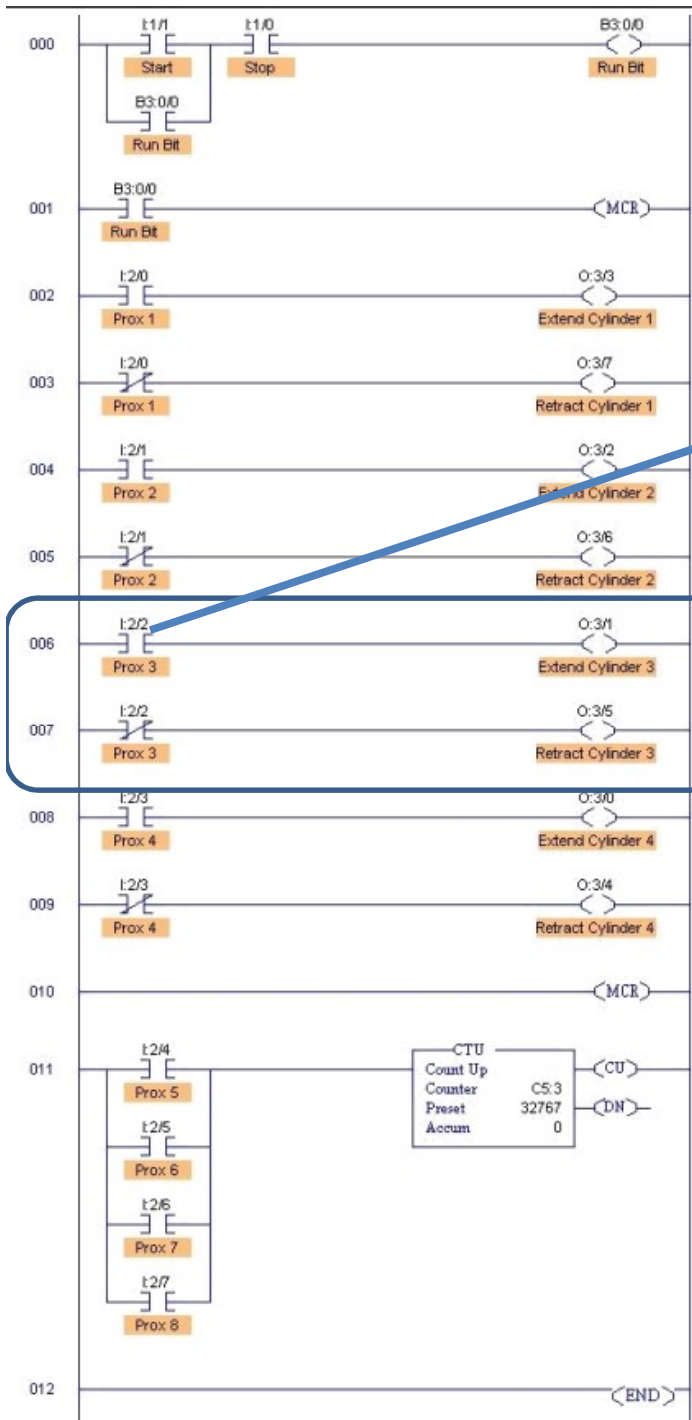

In location (B) you need to verify that the sensor is making this input on the card in the location mentioned in the tag



When the light is red, it means it is waiting in the off state.

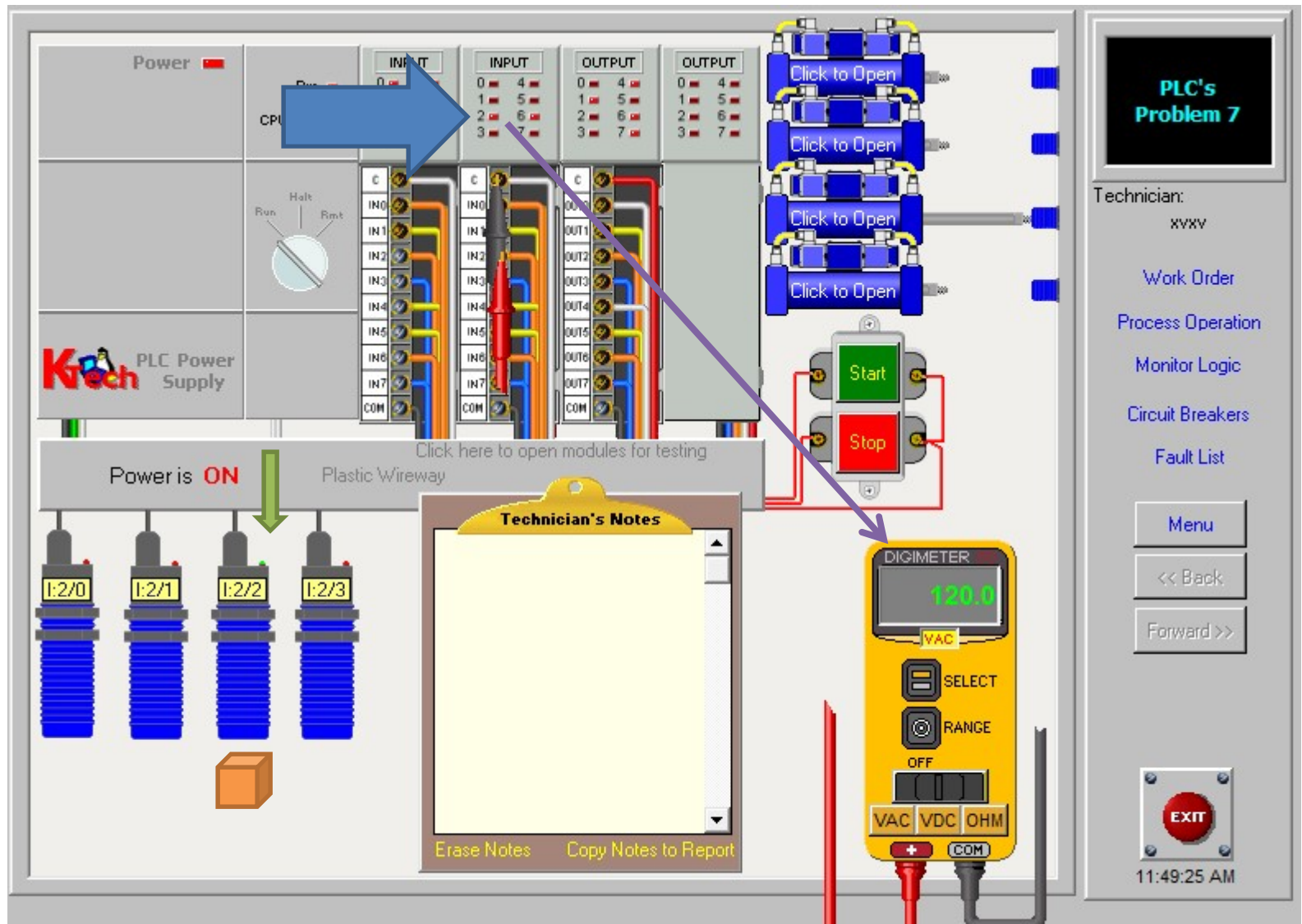

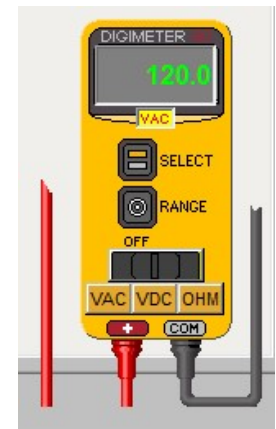
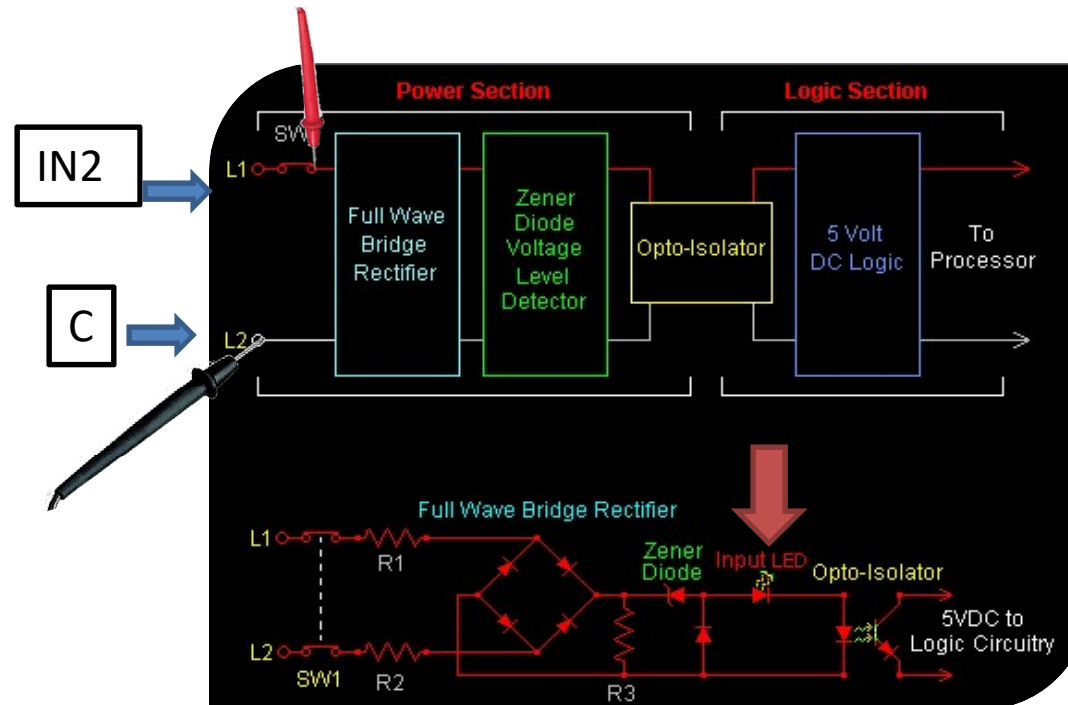
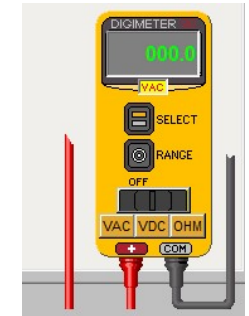
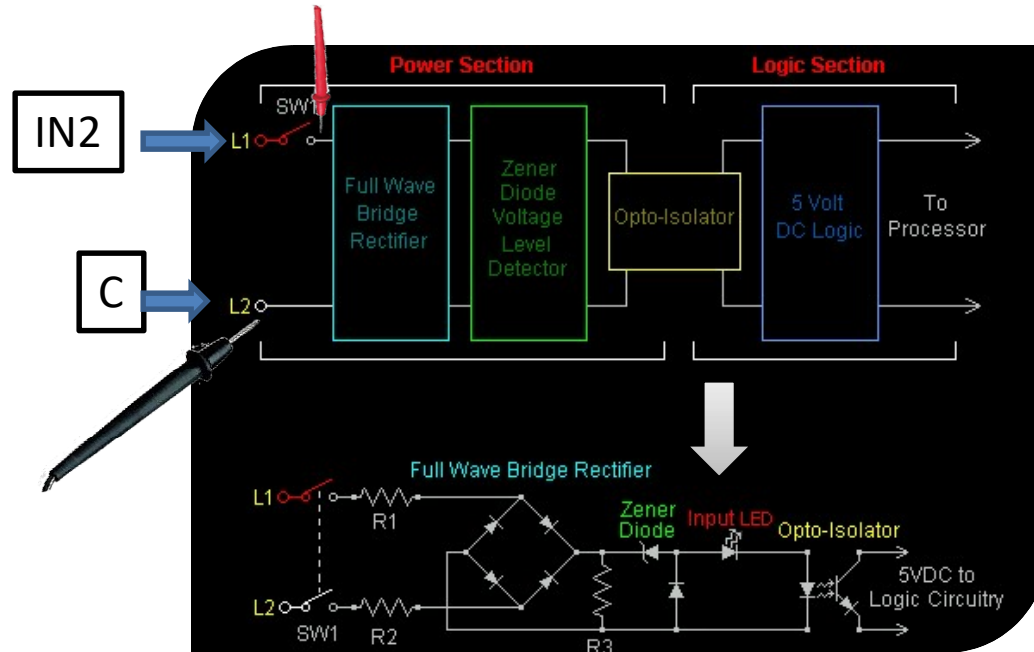
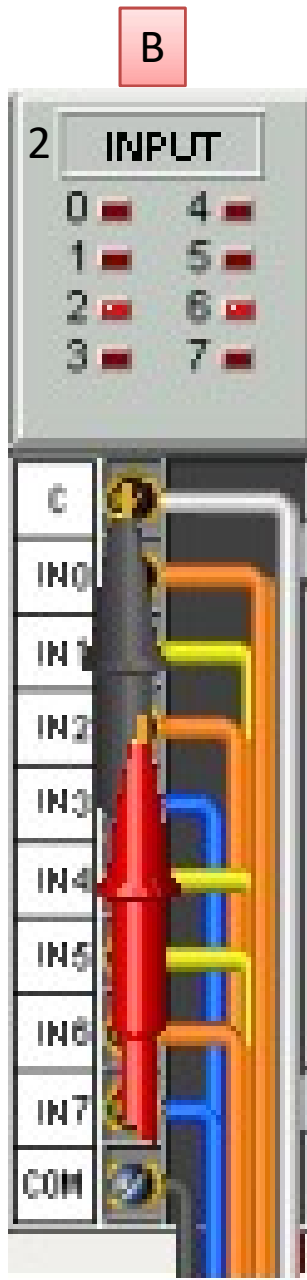



If the conditions are as shown in this presentation, then it is working correctly.

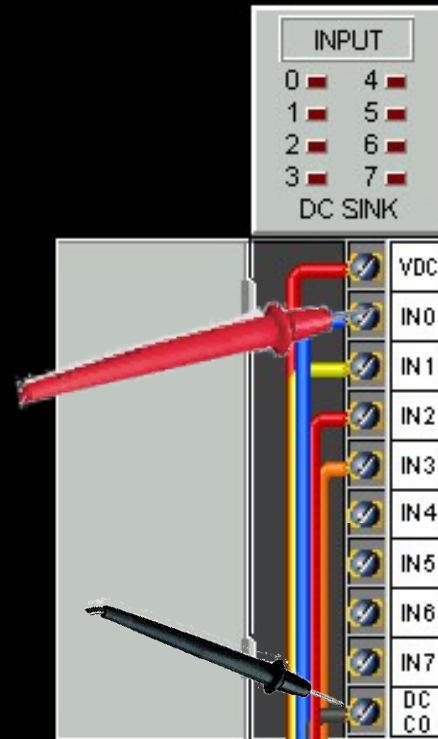

Opto-Isolation - Input Modules



If the conditions are as shown in this presentation, then it is working correctly.

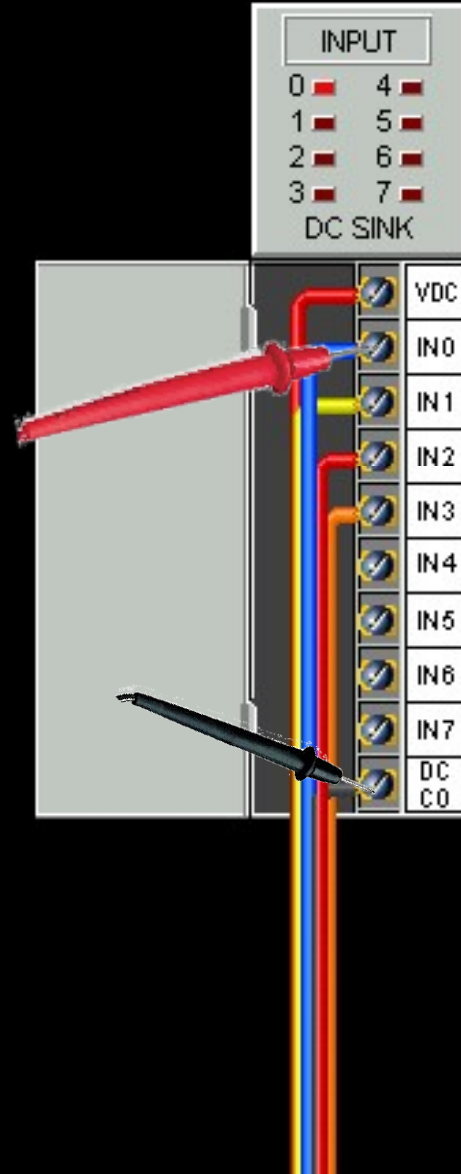

When the input (I:1/0) button is on and the light on input (0) does not turn on, it means that the input or the input card may be damaged, or this input was not programmed and is not registering the tag.

If the conditions are as shown in this presentation, it is malfunctioning.

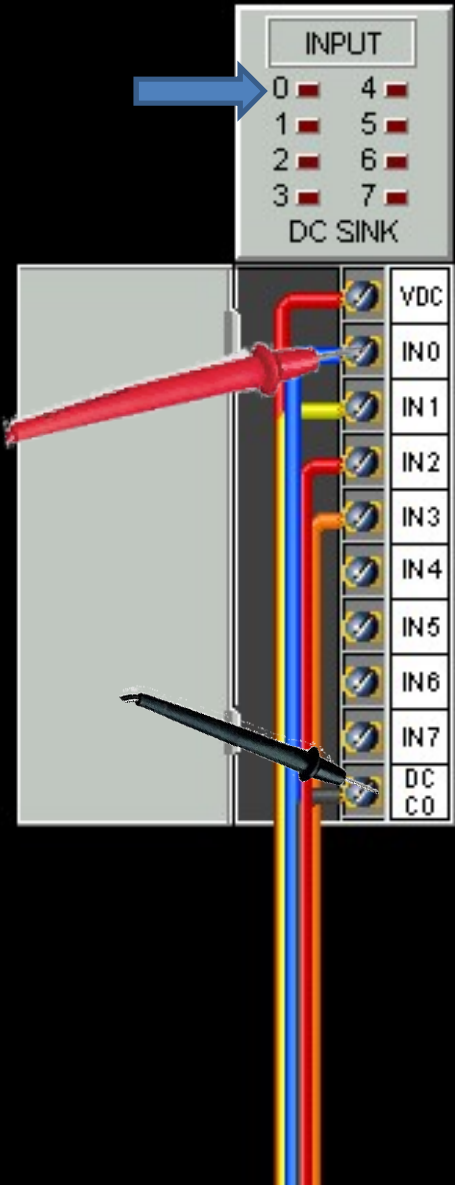
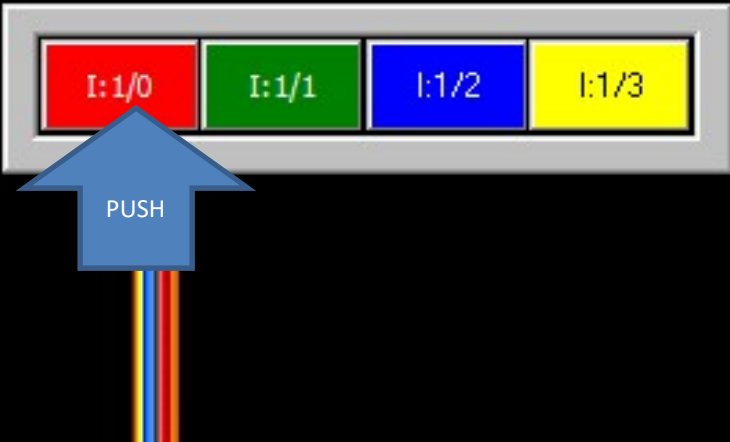

PLC's Problem 7

Technician:
XXXX

- Work Order
- Process Operation
- Monitor Logic
- Circuit Breakers
- Fault List

Menu
<< Back
Forward >>

EXIT
11:49:25 AM

Power ■

Run ■
Halt ■
CPU Fault ■

INPUT		INPUT		OUTPUT		OUTPUT	
0	4	0	4	0	4	0	4
1	5	1	5	1	5	1	5
2	6	2	6	2	6	2	6
3	7	3	7	3	7	3	7

Click to Open

Click to Open

Click to Open

Click to Open

Start

Stop

The entrance light comes on and voltage is detected on the voltmeter

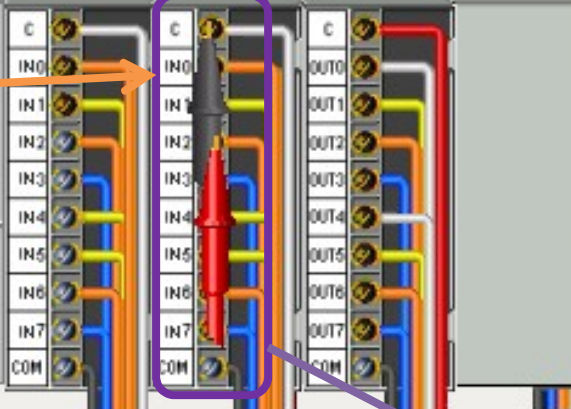

Click here to open modules for testing

Power is ON

Plastic Wireway

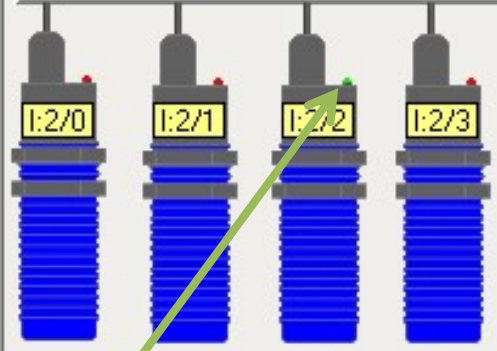

The sensor light is working correctly and voltage is being registered at its input.

Technician's Notes

input signal good

This example demonstrates troubleshooting a PLC input using the software simulation program. The exercise was not completed to avoid compromising the results and damaging the software. You can purchase it at (<https://bin95.com/>); they hold the rights.

Erase Notes Copy Notes to Report

DIGIMETER

120.0

VAC

SELECT

RANGE

OFF

VAC VDC OHM

COM