

Safety in the Workplace

1



Chapter Objectives

This chapter will help you to:

1. Identify the electrical factors that determine the severity of an electric shock.
2. Be aware of general principles of electrical safety including wearing approved protective clothing and using protective equipment.
3. Explain the safety aspect of grounding an electrical motor installation.
4. Outline the basic steps in a lockout procedure.
5. Be aware of the functions of the different organizations responsible for electrical codes and standards.

Safety is the number one priority in any job. Every year, electrical accidents cause serious injury or death. Many of these casualties are young people just entering the workplace. They are involved in accidents that result from carelessness, from the pressures and distractions of a new job, or from a lack of understanding about electricity. This chapter is designed to develop an awareness of the dangers associated with electrical power and the potential dangers that can exist on the job or at a training facility.

PART 1 Protecting against Electrical Shock

Electrical Shock

The human body conducts electricity. Even low currents may cause severe health effects. Spasms, burns, muscle paralysis, or death can result, depending on the amount of the current



flowing through the body, the route it takes, and the duration of exposure.

The main factor for determining the severity of an electric shock is the amount of electric current that passes through the body. This current is dependent upon the voltage and the resistance of the path it follows through the body.

Electrical resistance (R) is the opposition to the flow of current in a circuit and is measured in ohms (Ω). The lower the body resistance, the greater the current flow and potential electric shock hazard. Body resistance can be divided into external (skin resistance) and internal (body tissues and blood stream resistance). Dry skin is a good insulator; moisture lowers the resistance of skin, which explains why shock intensity is greater when the hands are wet. Internal resistance is low owing to the salt and moisture content of the blood. There is a wide degree of variation in body resistance. A shock that may be fatal to one person may cause only brief discomfort to another. Typical body resistance values are:

- Dry skin—100,000 to 600,000 Ω
- Wet skin—1,000 Ω
- Internal body (hand to foot)—400 to 600 Ω
- Ear to ear—100 Ω

Thin or wet skin is much less resistant than thick or dry skin. When skin resistance is low, the current may cause little or no skin damage but severely burn internal organs and tissues. Conversely, high skin resistance can produce severe skin burns but prevent the current from entering the body.

Voltage (E) is the pressure that causes the flow of electric current in a circuit and is measured in units called volts (V). The amount of voltage that is dangerous to life varies with each individual because of differences in body resistance and heart conditions. Generally, any voltage above 30 V is considered dangerous.

Electric current (I) is the rate of flow of electrons in a circuit and is measured in amperes (A) or milli-amperes (mA). One milliamperes is one-thousandth of an ampere. The amount of current flowing through a person's body depends on the voltage and resistance. Body current can be calculated using the following Ohm's law formula:

$$\text{Current} = \frac{\text{Voltage}}{\text{Resistance}}$$

If you came into direct contact with 120 volts and your body resistance was 100,000, then the current that would flow would be:

$$I = \frac{120 \text{ V}}{100,000 \Omega}$$

$$= 0.0012 \text{ A}$$

$$= 1.2 \text{ mA } (0.0012 \times 1,000)$$

This is just about at the threshold of perception, so it would produce only a tingle.

If you were sweaty and barefoot, then your resistance to ground might be as low as 1,000 ohms. Then the current would be:

$$I = \frac{120 \text{ V}}{1,000 \Omega} = 0.12 \text{ A} = 120 \text{ mA}$$

This is a lethal shock, capable of producing ventricular fibrillation (rapid irregular contractions of the heart) and death!

Voltage is not as reliable an indication of shock intensity because the body's resistance varies so widely that it is impossible to predict how much current will result from a given voltage. The amount of current that passes through the body and the length of time of exposure are perhaps the two most reliable criteria of shock intensity. Once current enters the body it follows through the circulatory system in preference to the external skin. Figure 1-1 illustrates the relative magnitude and effect of electric current. It doesn't take much current to cause a painful or even fatal shock. A current of 1 mA (1/1000 of an ampere) can be felt. A current of 10 mA will produce a shock of sufficient intensity to prevent voluntary control of muscles, which explains why, in some cases, the victim of electric shock is unable to release grip on the conductor while the current is flowing. A current of 100 mA passing through the body for a second or longer can be fatal. Generally, any current flow above 0.005 A, or 5 mA, is considered dangerous.

A 1.5-V flashlight cell can deliver more than enough current to kill a human being, yet it is safe to handle. This is because the resistance of human skin is high enough to limit greatly the flow of electric current. In lower voltage circuits, resistance restricts current flow to very low values. Therefore, there is little danger of an electric shock. Higher voltages, on the other hand, can force enough current through the skin to produce a shock. The danger of harmful shock increases as the voltage increases.

The pathway through the body is another factor influencing the effect of an electric shock. For example, a current from hand to foot, which passes through the heart and part of the central nervous system, is far more dangerous than a shock between two points on the same arm (Figure 1-2).

AC (alternating current) of the common 60-Hz frequency is three to five times more dangerous than DC (direct current) of the same voltage and current value. DC tends to cause a convulsive contraction of the muscles, often forcing the victim away from further current exposure. The effects of AC on the body depend to a great extent on the frequency: low-frequency currents (50–60 Hz) are usually more dangerous than high-frequency currents. AC causes muscle spasm, often "freezing" the hand (the most common part of the body to make contact) to the circuit. The fist clenches around the current source, resulting in prolonged exposure with severe burns.



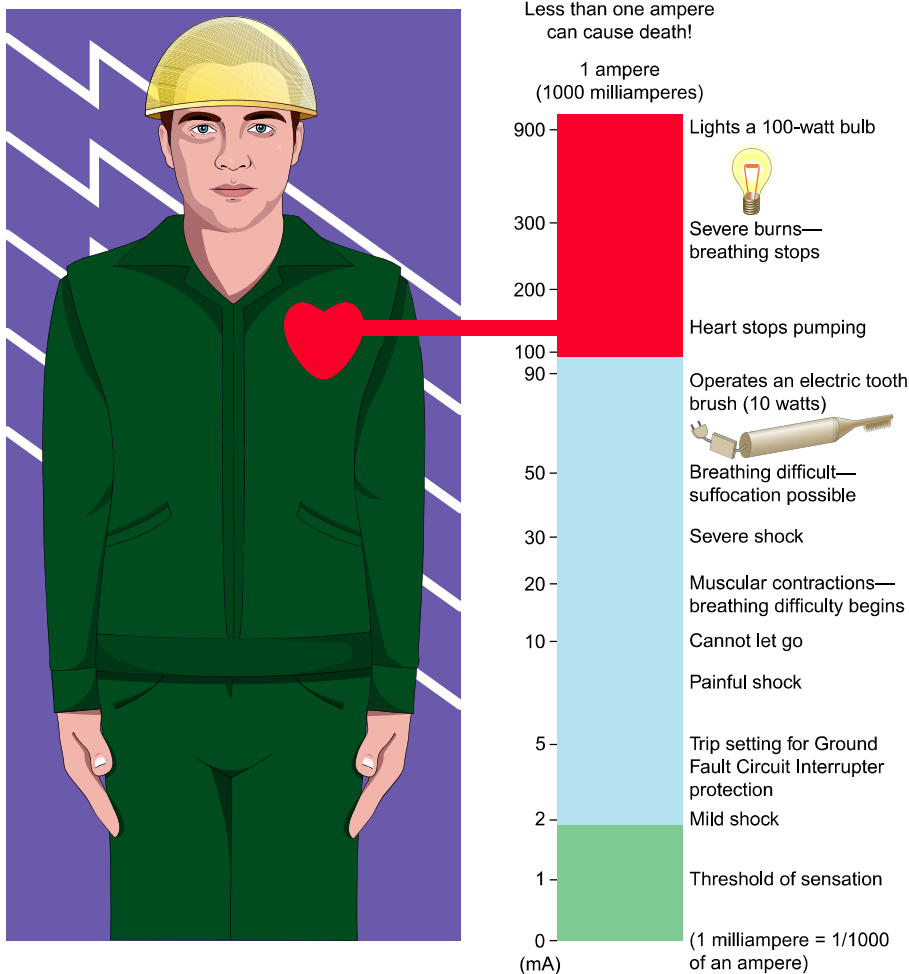

Figure 1-1 Relative magnitude and effect of electric current on the body.

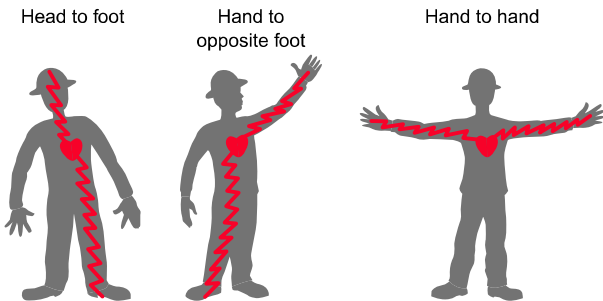

Figure 1-2 Typical electric current pathways that stop normal pumping of the heart.

The most common electric-related injury is a burn. The major types of burns:

- **Electrical burns**, which are a result of electric current flowing through the tissues or bones. The burn itself may be only on the skin surface or deeper layers of the skin may be affected.

- **Arc burns**, which are a result of an extremely high temperature caused by an electric arc (as high as 35,000 °F) in close proximity to the body. Electric arcs can occur as a result of poor electrical contact or failed insulation.
- **Thermal contact burns**, which are a result of the skin coming in contact with the hot surfaces of overheated components. They can be caused by contact with objects dispersed as a result of the blast associated with an electric arc.

If a person does suffer a severe shock, it is important to free the victim from the current as quickly as can be done safely. Do not touch the person until the electric power is turned off. You cannot help by becoming a second victim. The victim should be attended to immediately by a person trained in CPR (cardiopulmonary resuscitation).





Figure 1-3 Typical safety signs.

Personal Protective Equipment

Construction and manufacturing worksites, by nature, are potentially hazardous places. For this reason, safety has become an increasingly large factor in the working environment. The electrical industry, in particular, regards safety to be unquestionably the most single important priority because of the hazardous nature of the business. A safe operation depends largely upon all personnel being informed and aware of potential hazards. Safety signs and tags indicate areas or tasks that can pose a hazard to personnel and/or equipment. Signs and tags may provide warnings specific to the hazard, or they may provide safety instructions (Figure 1-3).

To perform a job safely, the proper protective clothing must be used. Appropriate attire should be worn for each particular job site and work activity (Figure 1-4). The following points should be observed:

1. Hard hats, safety shoes, and goggles must be worn in areas where they are specified. In addition, hard hats shall be approved for the purpose of the electrical work being performed. ***Metal hats are not acceptable!***
2. Safety earmuffs or earplugs must be worn in noisy areas.
3. Clothing should fit snugly to avoid the danger of becoming entangled in moving machinery. Avoid wearing synthetic-fiber clothing such as polyester material as these types of materials may melt or ignite when exposed to high temperatures and may



Figure 1-4 Appropriate attire should be worn for each particular job site and work activity.

Photo courtesy Capital Safety, www.capitalsafety.com.

- increase the severity of a burn. Instead always wear cotton clothing.
4. Remove all metal jewelry when working on energized circuits; gold and silver are excellent conductors of electricity.
 5. Confine long hair or keep hair trimmed when working around machinery.

A wide variety of electrical safety equipment is available to prevent injury from exposure to live electric circuits (Figure 1-5). Electrical workers should be familiar with safety standards such as NFP-70E that pertain to the type of protective equipment required, as well as how such equipment shall be cared for. To make sure electrical protective equipment actually performs as designed, it must be inspected for damage before each day's use and immediately following any incident that can reasonably be suspected of having caused damage. All electrical protection equipment must be listed and may include the following:

Rubber Protective Equipment—Rubber gloves are used to prevent the skin from coming into contact with energized circuits. A separate outer leather cover is used to protect the rubber glove from punctures and other damage. Rubber blankets are used to prevent contact with energized conductors or circuit parts when working near exposed energized circuits. All rubber protective equipment must be marked with the appropriate voltage rating and the last inspection date. It is important that the insulating value of both rubber gloves and blankets have a voltage rating that matches that of the circuit or equipment they are to be used with. Insulating gloves must be given an air test, along



Figure 1-5 Electrical safety equipment.

Photos: © Lab Safety Supply, Inc. Janesville, WI.



with inspection. Twirl the glove around quickly or roll it down to trap air inside. Squeeze the palm, fingers, and thumb to detect any escaping air. If the glove does not pass this inspection it must be disposed of.

Protection Apparel—Special protective equipment available for high-voltage applications include high-voltage sleeves, high-voltage boots, nonconductive protective helmets, nonconductive eyewear and face protection, switchboard blankets, and flash suits.

Hot Sticks—Hot sticks are insulated tools designed for the manual operation of high-voltage disconnecting switches, high-voltage fuse removal and insertion, as well as the connection and removal of temporary grounds on high-voltage circuits. A hot stick is made up of two parts, the head, or hood, and the insulating rod. The head can be made of metal or hardened plastic, while the insulating section may be wood, plastic, or other effective insulating materials.

Shorting Probes—Shorting probes are used on deenergized circuits to discharge any charged capacitors or built-up static charges that may be present when power to the circuit is disconnected. Also, when working on or near any high-voltage circuits, shorting probes should be connected and left attached as an extra safety precaution in the event of any accidental application of voltage to the circuit. When installing a shorting probe, first connect the test clip to a good ground contact. Next, hold the shorting probe by the handle and hook the probe end over the part or terminal to be grounded. Never touch any metal part of the shorting probe while grounding circuits or components.

Face Shields—Listed face shields should be worn during all switching operations where there is a possibility of injury to the eyes or face from electrical arcs or flashes, or from flying or falling objects that may result from an electrical explosion.

With proper precautions, there is no reason for you to ever receive a serious electrical shock. Receiving an electrical shock is a clear warning that proper safety measures have not been followed. To maintain a high level of electrical safety while you work, there are a number of precautions you should follow. Your individual job will have its own unique safety requirements. However, the following are given as essential basics.

- Never take a shock on purpose.
- Keep material or equipment at least 10 feet away from high-voltage overhead power lines.
- Do not close any switch unless you are familiar with the circuit that it controls and know the reason for its being open.

- When working on any circuit, take steps to ensure that the controlling switch is not operated in your absence. Switches should be padlocked open, and warning notices should be displayed (**lockout/tagout**).
- Avoid working on “live” circuits as much as possible.
- When installing new machinery, ensure that the framework is efficiently and permanently grounded.
- Always treat circuits as “live” until you have proven them to be “dead.” Presumption at this point can kill you. It is a good practice to take a meter reading before starting work on a dead circuit.
- Avoid touching any grounded objects while working on electrical equipment.
- Remember that even with a 120-V control system, you may well have a higher voltage in the panel. Always work so that you are clear of any of the higher voltages. (Even though you are testing a 120-V system, you are most certainly in close proximity to 240-V or 480-V power.)
- Don’t reach into energized equipment while it is being operated. This is particularly important in high-voltage circuits.
- Use good electrical practices even in temporary wiring for testing. At times you may need to make alternate connections, but make them secure enough so that they are not in themselves an electrical hazard.
- When working on live equipment containing voltages over approximately 30-V, work with only one hand. Keeping one hand out of the way greatly reduces the possibility of passing a current through the chest.
- Safely discharge capacitors before handling them. Capacitors connected in live motor control circuits can store a lethal charge for a considerable time after the voltage to the circuits has been switched off. Although Article 460 of the National Electric Code (NEC) requires an automatic discharge within 1 minute, never assume that the discharge is working! Always verify that there is no voltage present.

Confined spaces can be found in almost any workplace. Figure 1-6 illustrates examples of typical confined spaces. In general, a “confined space” is an enclosed or partially enclosed space that:

- Is not primarily designed or intended for human occupancy.
- Has a restricted entrance or exit by way of location, size, or means.
- Can represent a risk for the health and safety of anyone who enters, because of its design, construction, location, or atmosphere; the materials or substances



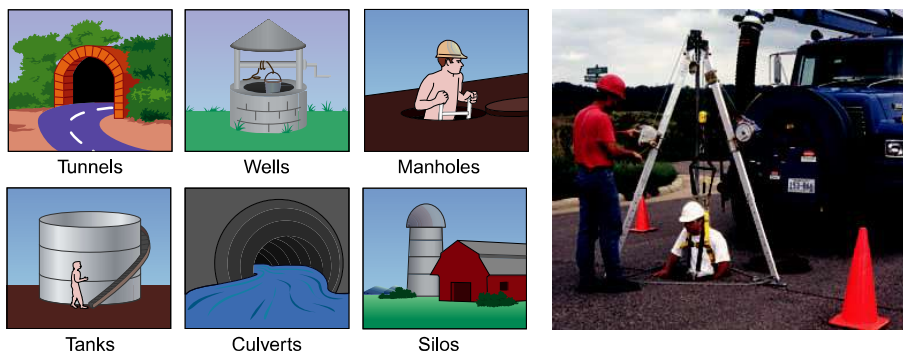

Figure 1-6 Confined spaces.
Photo courtesy Capital Safety, www.capitalsafety.com.

in it; work activities being carried out in it; or the mechanical, process, and safety hazards present.

All hazards found in a regular workspace can also be found in a confined space. However, they can be even more hazardous in a confined space than in a regular worksite. Hazards in confined spaces can include poor air quality, fire hazard, noise, moving parts of equipment,

temperature extremes, poor visibility, and barrier failure resulting in a flood or release of free-flowing solid. A “permit-required confined space” is a confined space that has specific health and safety hazards associated with it. Permit-required confined spaces require assessment of procedures in compliance with Occupational Safety and Health Administration (OSHA) standards prior to entry.

? PART 1 Review Questions

1. Does the severity of an electric shock increase or decrease with each of the following changes?
 - a. A decrease in the source voltage
 - b. An increase in body current flow
 - c. An increase in body resistance
 - d. A decrease in the length of time of exposure
2. a. Calculate the theoretical body current flow (in amperes and milliamperes) of an electric shock victim who comes in contact with a 120-V energy source. Assume a total resistance of 15,000 Ω (skin, body, and ground contacts).
 - b. What effect, if any, would this amount of current likely have on the body?
3. Normally a 6-volt lantern battery capable of delivering 2 A of current is considered safe to handle. Why?
 4. Why is AC of a 60-Hz frequency considered to be potentially more dangerous than DC of the same voltage and current value?
 5. State the piece of electrical safety equipment that should be used to perform each of the following tasks:
 - a. A switching operation where there is a risk of injury to the eyes or face from an electric arc.
 - b. Using a multimeter to verify the line voltage on a 3-phase 480 volt system.
 - c. Opening a manually operated high-voltage disconnect switch.
 6. Outline the safety procedure to follow when you are connecting shorting probes across deenergized circuits.
 7. List three pieces of personal protection equipment required to be worn on most job sites.

PART 2 Grounding—Lockout—Codes

Grounding and Bonding

Proper grounding practices protect people from the hazards of electric shock and ensure the correct operation of

overcurrent protection devices. Intentional grounding is required for the safe operation of electrical systems and equipment. Unintentional or accidental grounding is considered a fault in electrical wiring systems or circuits.

“Grounding” is the intentional connection of a current-carrying conductor to the earth. For AC premises wiring



systems in buildings and similar structures, this ground connection is made on the line side of the service equipment and the supply source, such as a utility transformer. The prime reasons for grounding are:

- To limit the voltage surges caused by lightning, utility system operations, or accidental contact with higher-voltage lines.
- To provide a ground reference that stabilizes the voltage under normal operating conditions.
- To facilitate the operation of overcurrent devices such as circuit breakers, fuses, and relays under ground-fault conditions.

“Bonding” is the permanent joining together of metal parts that aren’t intended to carry current during normal operation, which creates an electrically conductive path that can safely carry current under ground-fault conditions. The prime reasons for bonding are:

- To establish an effective path for fault current that facilitates the operation of overcurrent protective devices.
- To minimize shock hazard to people by providing a low-impedance path to ground. Bonding limits the touch voltage when non-current-carrying metal parts are inadvertently energized by a ground fault.

The Code requires all metal used in the construction of a wiring system to be bonded to, or connected to, the ground system. The intent is to provide a low-impedance path back to the utility transformer in order to quickly clear faults. Figure 1-7 illustrates the ground-fault current path required to ensure that overcurrent devices operate to open the circuit. The earth is not considered an effective ground-fault current path. The resistance of earth is so high that very little fault current returns to the electrical supply source through the earth. For this reason the main bonding jumper is used to provide the connection between the grounded service conductor and the equipment grounding conductor at the service. Bonding jumpers may be located throughout the electrical system, but a main bonding jumper is located only at the service. Grounding is accomplished by connecting the circuit to a metal underground water pipe, the metal frame of a building, a concrete-encased electrode, or a ground ring.

A grounding system has two distinct parts: system grounding and equipment grounding. System grounding is the electrical connection of one of the current carrying conductors of the electrical system to the ground. Equipment grounding is the electrical connection of all the metal parts that do not carry current of all electrical

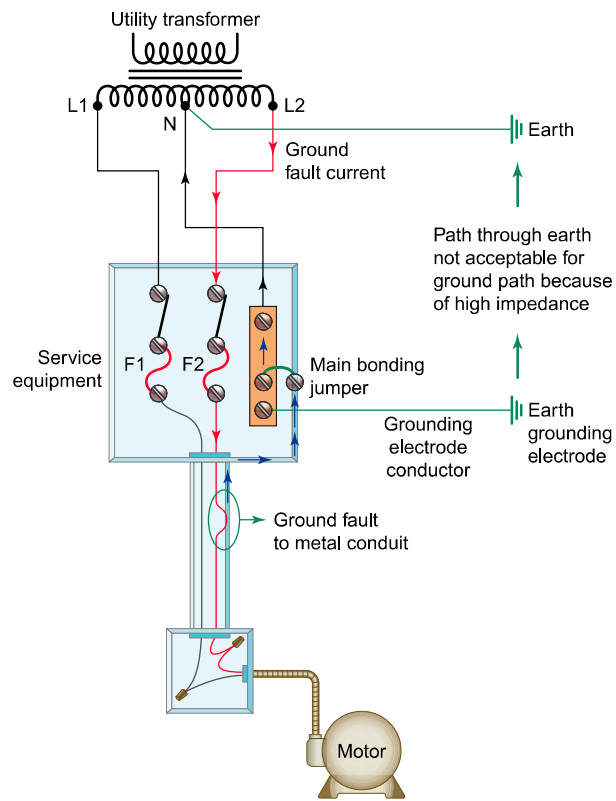

Figure 1-7 Ground-fault current path.

equipment to the ground. Conductors that form parts of the grounding system include the following:

Equipment grounding conductor (EGC) is an electrical conductor that provides a low-impedance ground path between electrical equipment and enclosures within the distribution system. Figure 1-8 shows the connection for an EGC. Electrical motor windings are normally insulated from all exposed non-current-carrying metal parts of the motor. However, if the insulation system should fail, then the motor frame could become energized at line voltage. Any person contacting a grounded surface and the energized motor frame simultaneously could be severely injured or killed. Effectively grounding the motor frame forces it to take the same zero potential as the earth, thus preventing this possibility.

Grounded conductor is a conductor that has been intentionally grounded.

Grounding electrode conductor is a conductor used to connect the equipment grounding conductor or the grounded conductor (at the service or at the separately derived system) to the grounding electrode(s).



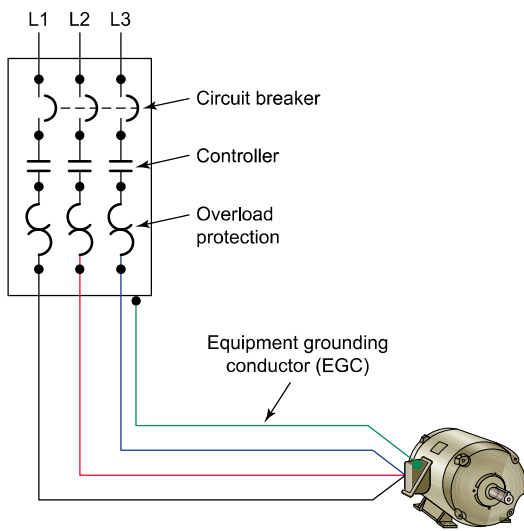

Figure 1-8 Equipment grounding conductor (EGC).

A separately derived system is a system that supplies electrical power derived (taken) from a source other than a service, such as the secondary of a distribution transformer.

A ground fault is defined as an unintentional, electrically conducting connection between an ungrounded conductor of an electric circuit and the normally non-current-carrying conductors, metallic enclosures, metallic raceways, metallic equipment, or earth. The ground-fault circuit interrupter (GFCI) is a device that can sense small ground-fault currents. The GFCI is fast acting; the unit will shut off the current or interrupt the circuit within 1/40 second after its sensor detects a leakage as small as 5 milliamperes (mA). Most circuits are protected against overcurrent by 15 ampere or larger fuses or circuit breakers. This protection is adequate against short circuits and overloads. Leakage currents to ground may be much less than 15 amperes and still be hazardous.

Figure 1-9 shows the simplified circuit of a GFCI receptacle. The device compares the amount of current in the ungrounded (hot) conductor with the amount of current in the grounded (neutral) conductor. Under normal operating conditions, the two will be equal in value. If the current in the neutral conductor becomes less than the current in the hot conductor, a ground-fault condition exists. The amount of current that is missing is returned to the source by the ground-fault path. Whenever the ground-fault current exceeds approximately 5 mA the device automatically opens the circuit to the receptacle.

GFCIs can be used successfully to reduce electrical hazards on construction sites. The ground-fault protection rules and regulations of OSHA have been determined

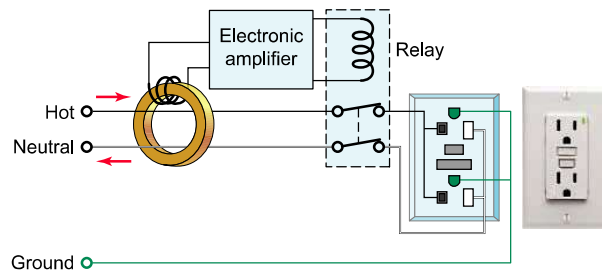

Zero current flows in this conductor under normal operating conditions.

Figure 1-9 GFCI receptacle.

Photo courtesy of The Leviton Manufacturing Company, www.leviton.com.

necessary and appropriate for employee safety and health. According to OSHA, it is the employer's responsibility to provide either: (1) ground-fault circuit interrupters on construction sites for receptacle outlets in use and not part of the permanent wiring of the building or structure, or (2) a scheduled and recorded assured equipment-grounding conductor program on construction sites, covering all cord sets, receptacles that are not part of the permanent wiring of the building or structure, and equipment connected by cord and plug that are available for use or used by employees.

Lockout and Tagout

Electrical "lockout" is the process of removing the source of electrical power and installing a lock, which prevents the power from being turned ON. Electrical "tagout" is the process of placing a danger tag on the source of electrical power, which indicates that the equipment may not be operated until the danger tag is removed (Figure 1-10). This procedure is necessary for the safety of personnel in



Figure 1-10 Lockout/tagout devices.

Photos courtesy Panduit Corporation, www.panduit.com.



that it ensures that no one will inadvertently energize the equipment while it is being worked on. Electrical lockout and tagout is used servicing electrical equipment that does not require power to be on to perform the service as in the case of motor alignment or replacement of a motor or motor control component.

Lockout means achieving a zero state of energy while equipment is being serviced. Just pressing a stop button to shut down machinery won't provide you with security. Someone else working in the area can simply reset it. Even a separate automated control could be activated to override the manual controls. It's essential that all interlocking or dependent systems also be deactivated. These could feed into the system being isolated, either mechanically or electrically. It's important to test the start button before resuming any work in order to verify that all possible energy sources have been isolated.

The "danger tag" has the same importance and purpose as a lock and is used alone only when a lock does not fit the disconnect means. Danger tags are required to be securely attached at the disconnect device with space provided for the worker's name, craft, and procedure that is taking place.

The following are the basic steps in a lockout procedure:

- **Prepare for machinery shutdown:** Document all lockout procedures in a plant safety manual. This manual should be available to all employees and outside contractors working on the premises. Management should have policies and procedures for safe lockout and should also educate and train everyone involved in locking out electrical or mechanical equipment. Identify the location of all switches, power sources, controls, interlocks, and other devices that need to be locked out in order to isolate the system.
- **Machinery or equipment shutdown:** Stop all running equipment by using the controls at or near the machine.
- **Machinery or equipment isolation:** Disconnect the switch (do not operate if the switch is still under load). Stand clear of the box and face away while operating the switch with the left hand (if the switch is on the right side of the box).
- **Lockout and tagout application:** Lock the disconnect switch in the OFF position. If the switch box is the breaker type, make sure the locking bar goes right through the switch itself and not just the box cover. Some switch boxes contain fuses, and these should be removed as part of the lockout process. If this is the case, use a fuse puller to remove them. Use a tamper-proof lock with one key, which is kept

by the individual who owns the lock. Combination locks, locks with master keys, and locks with duplicate keys are not recommended.

Tag the lock with the signature of the individual performing the repair and the date and time of the repair. There may be several locks and tags on the disconnect switch if more than one person is working on the machinery. The machine operator's (and/or the maintenance operator's) lock and tag will be present as well as the supervisor's.

- **Release of stored energy:** All sources of energy that have the potential to unexpectedly start up, energize, or release must be identified and locked, blocked, or released.
- **Verification of isolation:** Use a voltage test to determine that voltage is present at the line side of the switch or breaker. When all phases of outlet are dead with the line side live, you can verify the isolation. Ensure that your voltmeter is working properly by performing the "live-dead-live" check before each use: First check your voltmeter on a known live voltage source of the same voltage range as the circuit you will be working on. Next check for the presence of voltage on the equipment you have locked out (Figure 1-11). Finally, to ensure that your voltmeter did not malfunction, check it again on the known live source.
- **Lockout/tagout removal:** Remove tags and locks when the work is completed. Each individual must remove his or her own lock and tag. If there is more than one lock present, the person in charge of the work is the last to remove his or her lock. Before reconnecting the power, check that all guards are in



Figure 1-11 Testing for the presence of voltage. Photos courtesy Fluke, www.fluke.com. Reproduced with Permission.



place and that all tools, blocks, and braces used in the repair are removed. Make sure that all employees stand clear of the machinery.

Electrical Codes and Standards

OCCUPATIONAL SAFETY AND HEALTH ADMINISTRATION (OSHA)

In 1970, Congress created a regulatory agency known as the Occupational Safety and Health Administration (OSHA). The purpose of OSHA is to assure safe and healthful working conditions for working men and women by authorizing enforcement of standards developed under the Act, by encouraging and assisting state governments to improve and expand their own occupational safety and health programs, and by providing for research, information, education, and training in the field of occupational health and safety.

OSHA inspectors check on companies to make sure they are following prescribed safety regulations. OSHA also inspects and approves safety products. OSHA's electrical standards are designed to protect employees exposed to dangers such as electric shock, electrocution, fires, and explosions.

NATIONAL ELECTRICAL CODE (NEC)

The National Electrical Code (NEC) comprises a set of rules that, when properly applied, are intended to provide a safe installation of electrical wiring and equipment. This widely adopted minimum electrical safety standard has as its primary purpose "the practical safeguarding of persons and property from hazards arising from the use of electricity." Standards contained in the NEC are enforced by being incorporated into the different city and community ordinances that deal with electrical installations in residences, industrial plants, and commercial buildings. The NEC is the most widely adopted code in the world and many jurisdictions adopt it in its entirety without exception or local amendments or supplements.

An "Article" of the Code covers a specific subject. For example, Article 430 of the NEC covers motors and all associated branch circuits, overcurrent protection, overload, and so on. The installation of motor-control centers is covered in Article 408, and air-conditioning equipment is covered in Article 440. Each Code rule is called a "Code Section." A Code Section may be broken down into subsections. For example, the rule that requires a motor disconnecting means be mounted within sight of the motor and driven machinery is contained in Section 430.102 (B). "In sight" is defined by the Code as visible and not more than 50 feet in distance (Article 100—definitions).

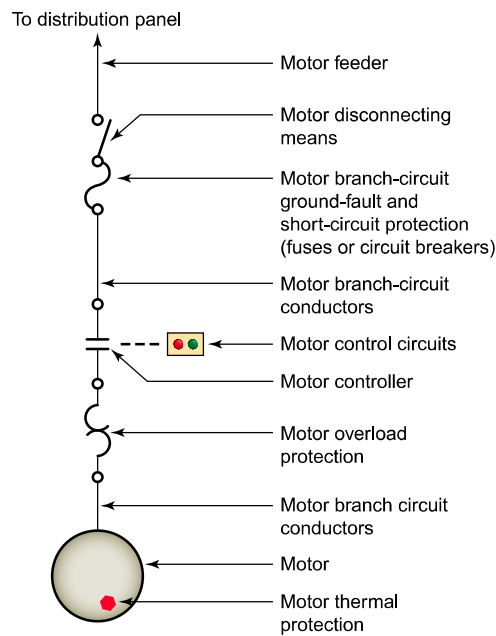

Figure 1-12 Motor terminology.

Article 430 on motors is the longest article in the Code. One of the reasons for this is that the characteristics of a motor load are quite different from heating or incandescent lighting loads and so the method of protecting branch circuit conductors against excessive current is slightly different. Non-motor branch circuits are protected against overcurrent, whereas motor branch circuits are protected against overload conditions as well as groundfaults and short circuits. The single-line diagram of Figure 1-12 illustrates some of the motor terminology used throughout the Code and by motor control equipment manufacturers.

The use of electrical equipment in hazardous locations increases the risk of fire or explosion. Hazardous locations can contain gas, dust (e.g., grain, metal, wood, or coal), or flying fibers (textiles or wood products). A substantial part of the NEC is devoted to the discussion of hazardous locations, because electrical equipment can become a source of ignition in these volatile areas. Articles 500 through 504 and 510 through 517 provide classification and installation standards for the use of electrical equipment in these locations. Explosion-proof apparatus, dust-ignition-proof equipment, and purged and pressurized equipment are examples of protection techniques that can be used in certain hazardous (classified) locations. Figure 1-13 shows a motor start/stop station designed to meet hazardous location requirements.





Figure 1-13 Push button station designed for hazardous locations.

Photo courtesy Rockwell Automation, www.rockwellautomation.com.

NATIONAL FIRE PROTECTION ASSOCIATION (NFPA)

The National Fire Protection Association (NFPA) develops codes governing construction practices in the building and electrical trades. It is the world's largest and most influential fire safety organization. NFPA has published almost 300 codes and standards, including the National Electrical Code, with the mission of preventing the loss of life and property. Fire prevention is a very important part of any safety program. Figure 1-14 illustrates some of the common types of fire extinguishers and their applications. Icons found on the fire extinguisher indicate the types of fire the unit is intended to be used on.

It is important to know where your fire extinguishers are located and how to use them. In case of an electrical fire the following procedures should be followed:

1. Trigger the nearest fire alarm to alert all personnel in the workplace as well as the fire department.
2. If possible, disconnect the electric power source.
3. Use a carbon dioxide or dry-powder fire extinguisher to put out the fire. *Under no circumstances use*



Figure 1-14 Types of fire extinguishers and their applications.

water, as the stream of water may conduct electricity through your body and give you a severe shock.

4. Ensure that all persons leave the danger area in an orderly fashion.
5. Do not reenter the premises unless advised to do so.

There are four classes of fires, categorized according to the kind of material that is burning (see Figure 1-14):

- **Class A** fires are those fueled by materials that, when they burn, leave a residue in the form of ash, such as paper, wood, cloth, rubber, and certain plastics.
- **Class B** fires involve flammable liquids and gases, such as gasoline, paint thinner, kitchen grease, propane, and acetylene.
- **Class C** fires involve energized electrical wiring or equipment such as motors and panel boxes.
- **Class D** fires involve combustible metals such as magnesium, titanium, zirconium, sodium, and potassium.

NATIONALLY RECOGNIZED TESTING LABORATORY (NRTL)

Article 100 of the NEC defines the terms “labeled” and “listed,” which are both related with product evaluation. Labeled or listed indicates the piece of electrical equipment or material has been tested and evaluated for the purpose for which it is intended to be used. Products that are big enough to carry a label are usually labeled. The smaller products are usually listed. Any modification of a piece of electrical equipment in the field may void the label or listing.

In accordance with OSHA Safety Standards, a Nationally Recognized Testing Laboratory (NRTL) must test electrical products for conformity to national codes and standards before they can be listed or labeled. The biggest and best-known testing laboratory is the Underwriters' Laboratories, identified with the UL logo shown in Figure 1-15. The purpose of the Underwriters' Laboratories is to establish, maintain, and operate laboratories for the investigation of materials, devices, products, equipment, construction, methods, and systems with regard to hazards affecting life and property.



Figure 1-15 Underwriters' Laboratories logo.



NATIONAL ELECTRICAL MANUFACTURERS ASSOCIATION (NEMA)

The National Electrical Manufacturers Association (NEMA) is a group that defines and recommends safety standards for electrical equipment. Standards established by NEMA assist users in proper selection of industrial control equipment. As an example, NEMA standards provide practical information concerning the rating, testing, performance, and manufacture of motor control devices such as enclosures, contactors, and starters.

INTERNATIONAL ELECTROTECHNICAL COMMISSION (IEC)

The International Electrotechnical Commission (IEC) is a Europe-based organization made up of national committees from over 60 countries. There are basically two major mechanical and electrical standards for motors: NEMA in North America and IEC in most of the rest of the world. Dimensionally, IEC standards are expressed in metric units. Though NEMA and IEC standards use different units of measurements and terms, they are essentially

analogous in ratings and, for most common applications, are largely interchangeable. NEMA standards tend to be more conservative—allowing more room for “design interpretation,” as has been U.S. practice. Conversely, IEC standards tend to be more specific, more categorized—some say more precise—and designed with less overload capacity. As an example, a NEMA-rated motor starter will typically be larger than its IEC counterpart.

INSTITUTE OF ELECTRICAL AND ELECTRONICS ENGINEERS (IEEE)

The Institute of Electrical and Electronics Engineers (IEEE) is a technical professional association whose primary goal is to foster and establish technical developments and advancements in electrical and electronic standards. IEEE is a leading authority in technical areas. Through its technical publishing, conferences, and consensus-based standards activities, the IEEE produces more than 30 percent of the world’s published literature in electrical and electronic engineering. For example, IEEE Standard 142 provides all the information you need for a good grounding design.

PART 2 Review Questions

1. Explain how grounding the frame of a motor can prevent someone from receiving an electric shock.
2. Compare the terms *grounding* and *bonding*.
3. What is the minimum amount of leakage ground current required to trip a ground-fault circuit interrupter?
4. List the seven steps involved in a lockout/tagout procedure.
5. A disconnect switch is to be pulled open as part of a lockout procedure. Explain the safe way to proceed.
6. What is the prime objective of the National Electrical Code?
7. How are the standards contained in the NEC enforced?
8. Explain the difference between a Code Article and a Section.
9. What do the icons found on most fire extinguishers indicate?
10. What does a UL-labeled or -listed electrical device signify?
11. List three motor control devices that are rated by NEMA.
12. Compare NEMA and IEC motor standards.

TROUBLESHOOTING SCENARIOS

1. The voltage between the frame of a 3-phase 208-V motor and a grounded metal pipe is measured and found to be 120-V. What does this indicate? Why?
2. A ground-fault circuit interrupter does not provide overload protection. Why?
3. A listed piece of electrical equipment is not installed according to the manufacturer’s instructions. Discuss why this will void the listing.
4. A hot stick is to be used to open a manually operated high-voltage disconnect switch. Why is it important to make certain that no loads are connected to the circuit when the switch is opened?





1. Worker A makes contact with a live wire and receives a mild shock. Worker B makes contact with the same live wire and receives a fatal shock. Discuss some of the reasons why this might occur.
2. The victim of death by electrocution is found with his fist still clenched firmly around the live conductor he made contact with. What does this indicate?
3. Why can birds safely rest on high-voltage power lines without getting shocked?
4. You have been assigned the task of explaining the company lockout procedure to new employees. Outline what you would consider the most effective way of doing this.
5. Visit the website of one of the groups involved with electrical codes and standards. Report on the service it provides.

