

WARRIORS OFF ROAD



UNOFFICAL GUIDE

ENGINE REMOVAL AND REBUILD GUIDE FOR HISUN 250cc ENGINE FAMILY



THE FOLLOWING IS A STEP BY STEP GUIDE TO HELP YOU BETTER UNDERSTAND HOW TO REMOVE AND REBUILD THE HISUN 250cc ENGINE.

This is not a difficult job to do when you are either rebuilding the engine or changing out the transmission. Just take your time and this guide will walk you through the process step by step. Remember to always use the proper tools and safety equipment to prevent injury when removing the engine.

Step 1. place the UTV on jack stands to get it up in the air a bit and to allow you access under the unit to remove the plastic skid plates. Remove the 4 skid plates to reveal the bottom of the engine.

Step 2. Disconnect the battery connections. Now you will get access to the motor mount bolts and more.

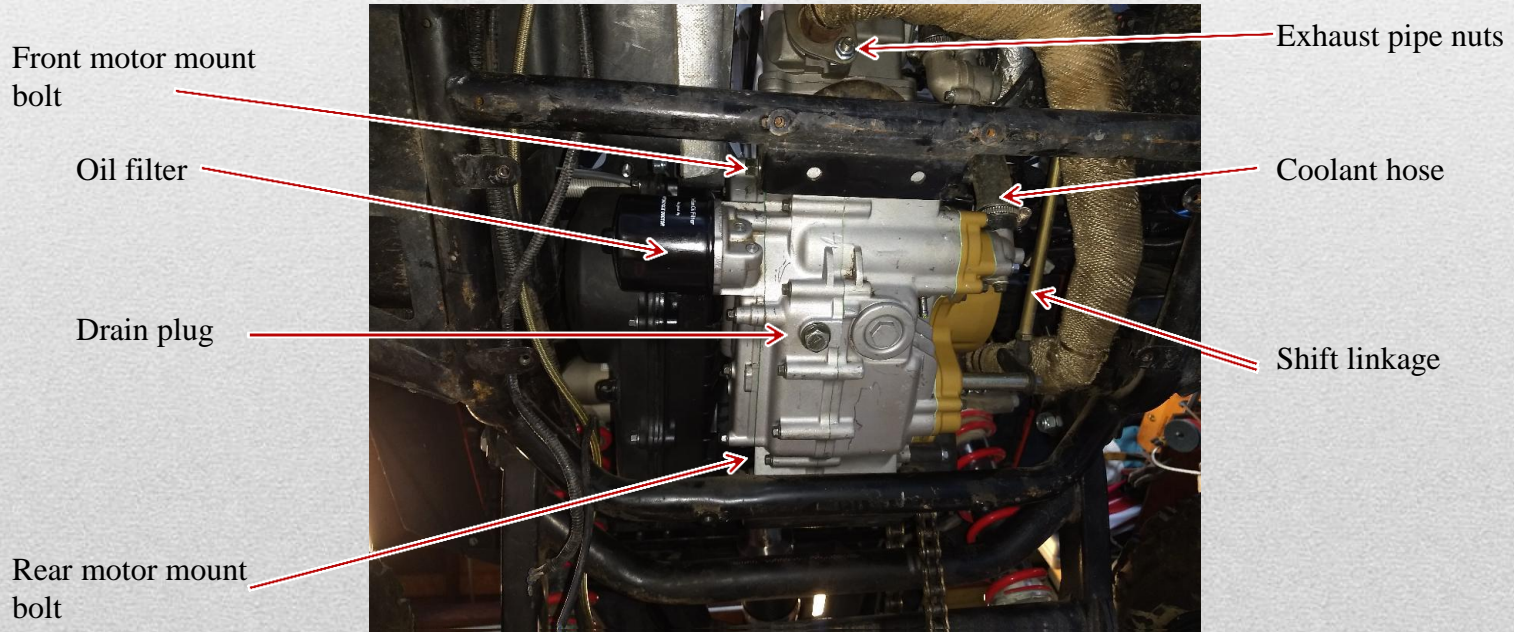

Step 3. Drain the engine oil

Step 4. Remove the coolant hose from the water pump and drain the fluid.

Step 5. Unbolt the shift linkage from the engine with a 8mm wrench.

Step 6. Unbolt the exhaust pipe from the engine and undue the springs at the mid pipe area to remove the pipe.

Step 7. Remove the seats from the top. They slide out forward. Remove the seat tracks as well at this point.

Step 8. Remove the shift knob (pic 1). This is done by popping off the top portion of the shift knob up. It will revel a philips screw inside. Once removed, you can pull the shift knob up and off.

Step 9. Remove the center console. Turn the tabs so that they are in line from front to rear and then pull up on the console.

Step 10. Start to unplug the wiring inside the battery compartment. Make sure to take a pic of this to make re installing easier. Mark the wiring if needed (pic 3).

Step 11. Remove both right and left body side panels. It will give you access to the engine area and wiring.

Step 12. This part is one of the hardest, you will now need to remove the large plastic engine cover under the seat area (pic 2). This plastic is hard and will crack if bent to much. Lots of screws to remove. You will need to remove the seat belt bolts as well.

Step 13. Now that the engine is exposed you will need to remove the metal cross member (pic 4). It is routed under the intake so its best to remove the intake manifold off the engine and air filter assembly as a whole unit. You can keep the throttle cable connected if needed, just place the entire intake in the passenger floorboard area. Make sure to tape the intake hole to prevent dirt from entering the engine and the throttle body.

1



Shift knob

2



Engine cover

3



Battery area

4

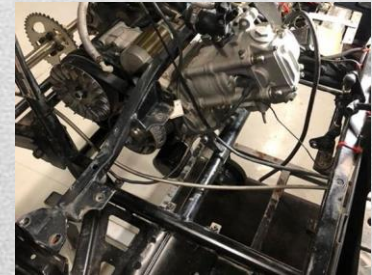

Cross member

Step 14. With the cross member removed, you now have access to the engine. Remove the coolant hoses from the engine and out of the way.

Step 15, loosen the rear axle so that the chain can be removed from the engine front sprocket.

Step 16. Remove the spark plug wire and set aside.

Step 17. You will now remove the fuel tank and set aside. It is held in place with two bolts. Disconnect the two electrical connectors for the fuel pump and sending unit. Remove the small clip on the fuel line to the fuel pump. Do not loose this clip. Twist the fuel line a bit to break the seal and it should pull up and off of the fuel tank. Make sure not to loose the special O rings as well. (Pic 5) Set the fuel tank in a safe place that has ventilation for safety.

Step 17. Remove the two engine mount bolts. You can access them under the chassis easier.

5



Fuel hose clip

6



Step 18. Now you can lift the engine up and out of the chassis and put on a bench or work station. (Pic 6)

The following steps will guide you through the process of tearing down and rebuilding the engine. Installation is in the reverse order. Remember to take pics, follow the guide and contact me with any questions during this process.

This guide covers engines from 2015-current. 250cc engine family produced by HiSUN. This will also cover engines in Bennche, Massimo and Coleman UTV's all of which are produced by HiSUN.

Engine specifications are:

- 229cc
- Single cylinder 4 stroke
- Water cooled
- 2 Valve cylinder head
- EFI intake
- CVT clutch
- Wet sump oil system
- Engine Family: HS1P65MM for HS250UTV
- Compression ratio 9.7:1



- Bore X Stroke: 65.5×68mm (2.58×2.68in)
- Normal Compression: 188 psi

Start by draining the engine oil and any coolant. Next step is to remove the clutch side cover (a)

10mm bolts x 7

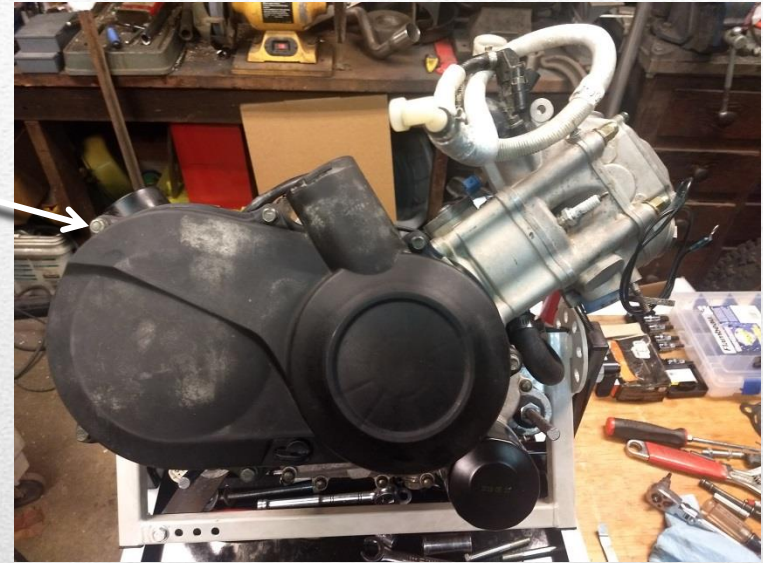

(a)

Inspect the rubber gasket to the clutch cover for damage or wear.

OIL FILTER

(b)



Remove the 19mm nut on the Variator side of the clutch. Take note that the special washer has a beveled edge. This bevel faces the splines on the shaft of the Variator. *If a washer is used without this bevel, it will cause the clutch to operate improperly.*

Special Beveled Washer

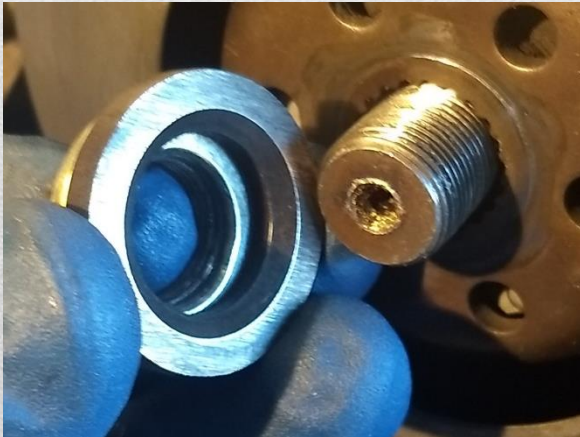

Next is to remove the Variator and set aside. You will now be ready to remove the main clutch assembly. Use 2 of the 10mm bolts that held the clutch plastic cover on and you will use them to help push the clutch open to aid in removing the CVT belt.

Locate the 2 threaded holes on the face of the clutch sheave.

Clutch sheave face

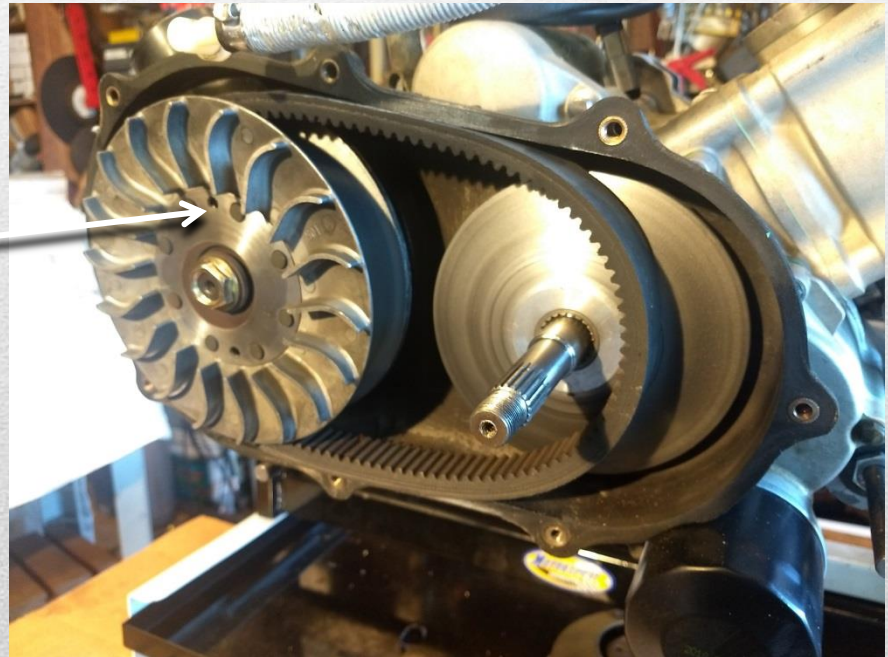

Insert the 2
10mm bolts
into the holes
and tighten
them evenly.
This will push
open the clutch
sheaves and
allow the belt
to be removed
easily.



Once the CVT belt is removed, you will now remove the rear sheave behind the variator.

Now you can remove the 19mm nut securing the clutch assembly in place. Take note that the shaft the nut is on may spin freely if the engine is in neutral. To assist removal, try rotating the shift rod on the opposite side of the engine to engage the transmission. You can also secure the countershaft sprocket to stop the shaft from turning.

Once the nut is removed, you can pull the clutch straight out and off of the shaft. The washer used on this shaft is not beveled.

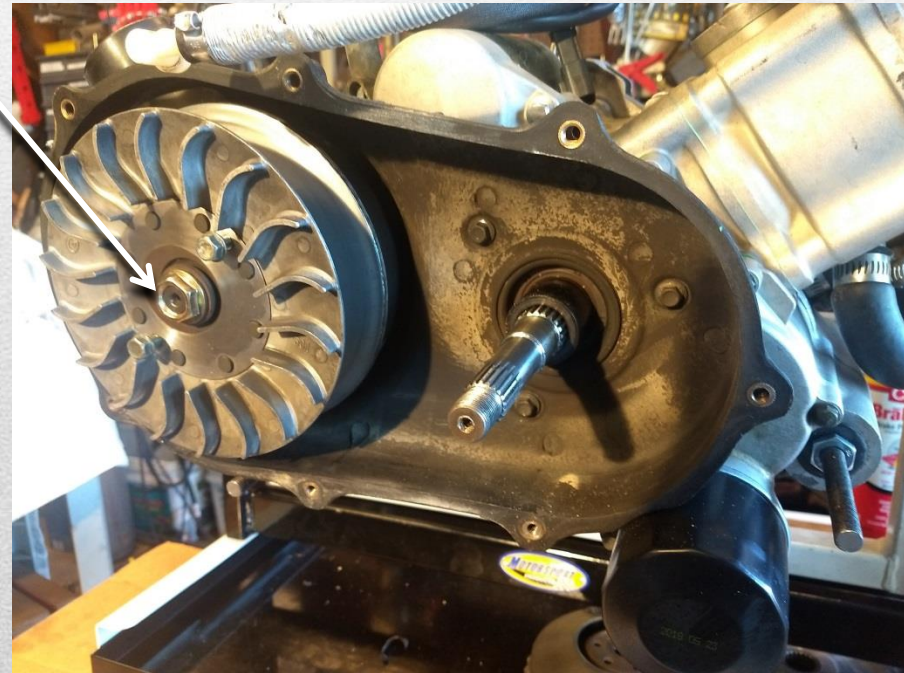

Here you should see the clutch bell along with a special sized washer. This washer rides on the bearing in the clutch assembly and correctly spaces out the clutch bell from the clutch.

Now you can pull the clutch bell and washer out and set aside



Here is the clutch housing. There are 6 bolts total securing it to the engine. Remove the 3 screws behind the clutch, and the 3 bolts behind the Variator.

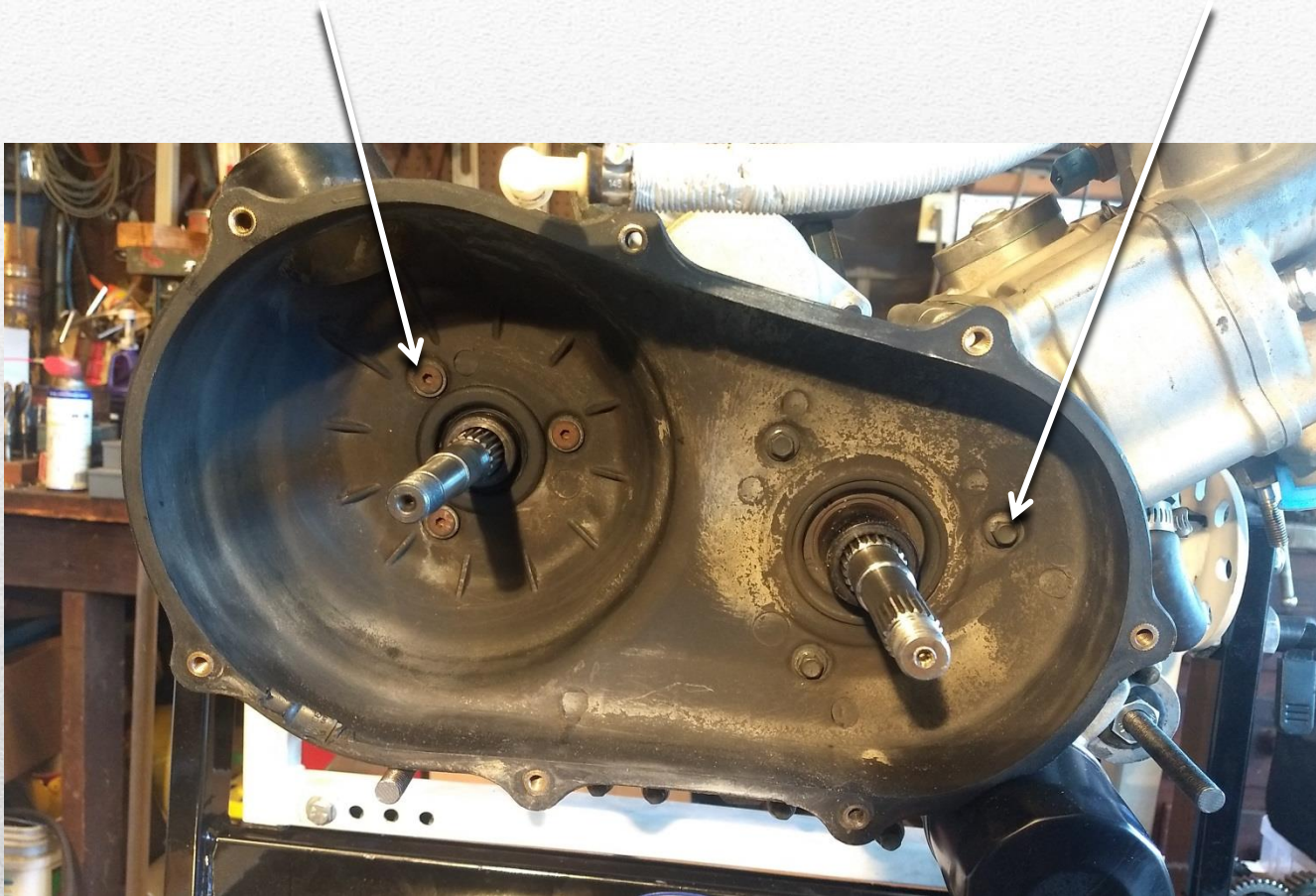

Use blue loctite when re installing as they can some loose and cause damage

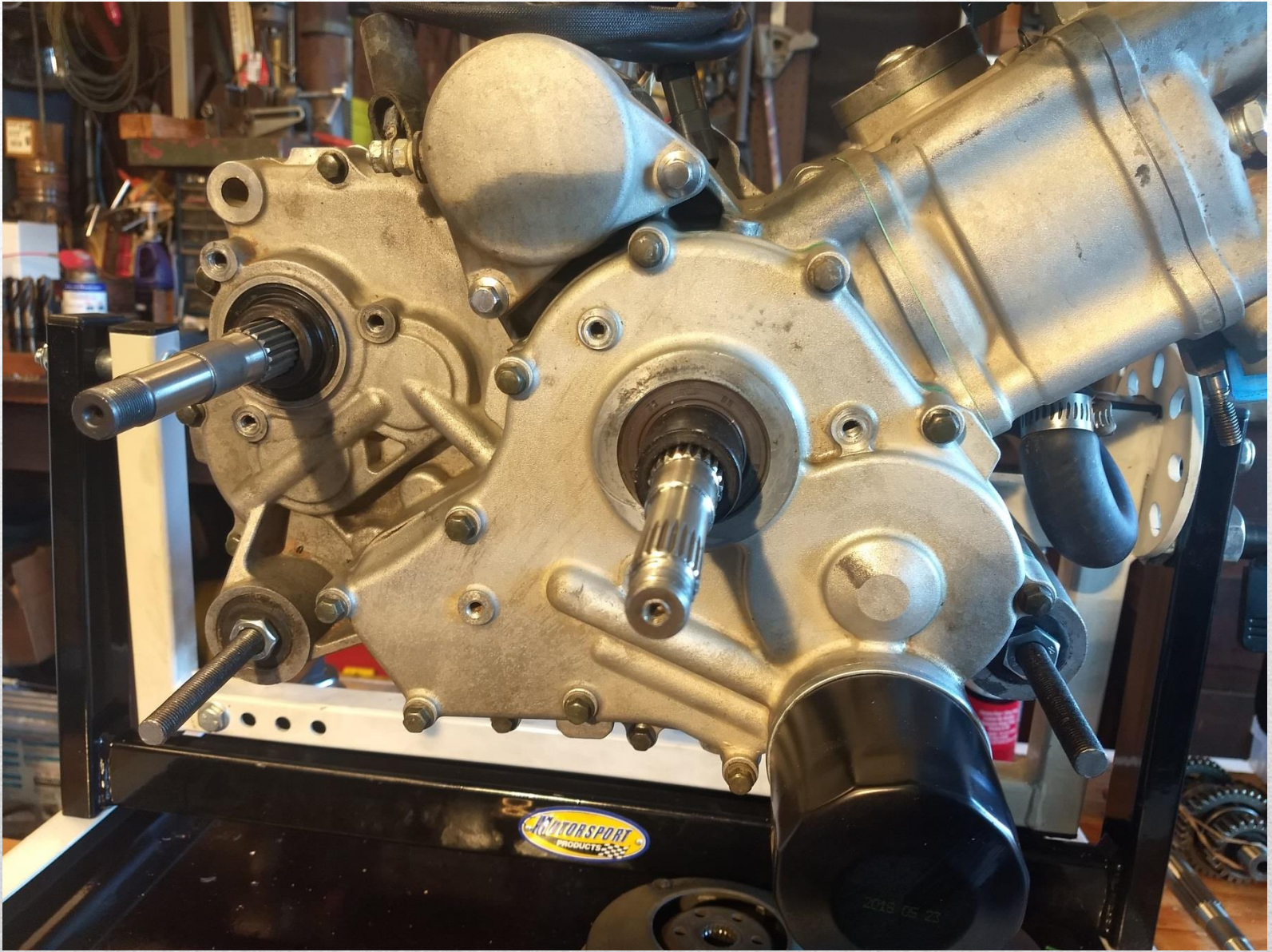

To remove the right side cover, there is a hidden bolt behind the oil filter. Remove the oil filter and locate the allen head bolt. Remove this bolt along with the remaining 8mm hex head bolts securing the side cover on. Pull straight off of the shaft.

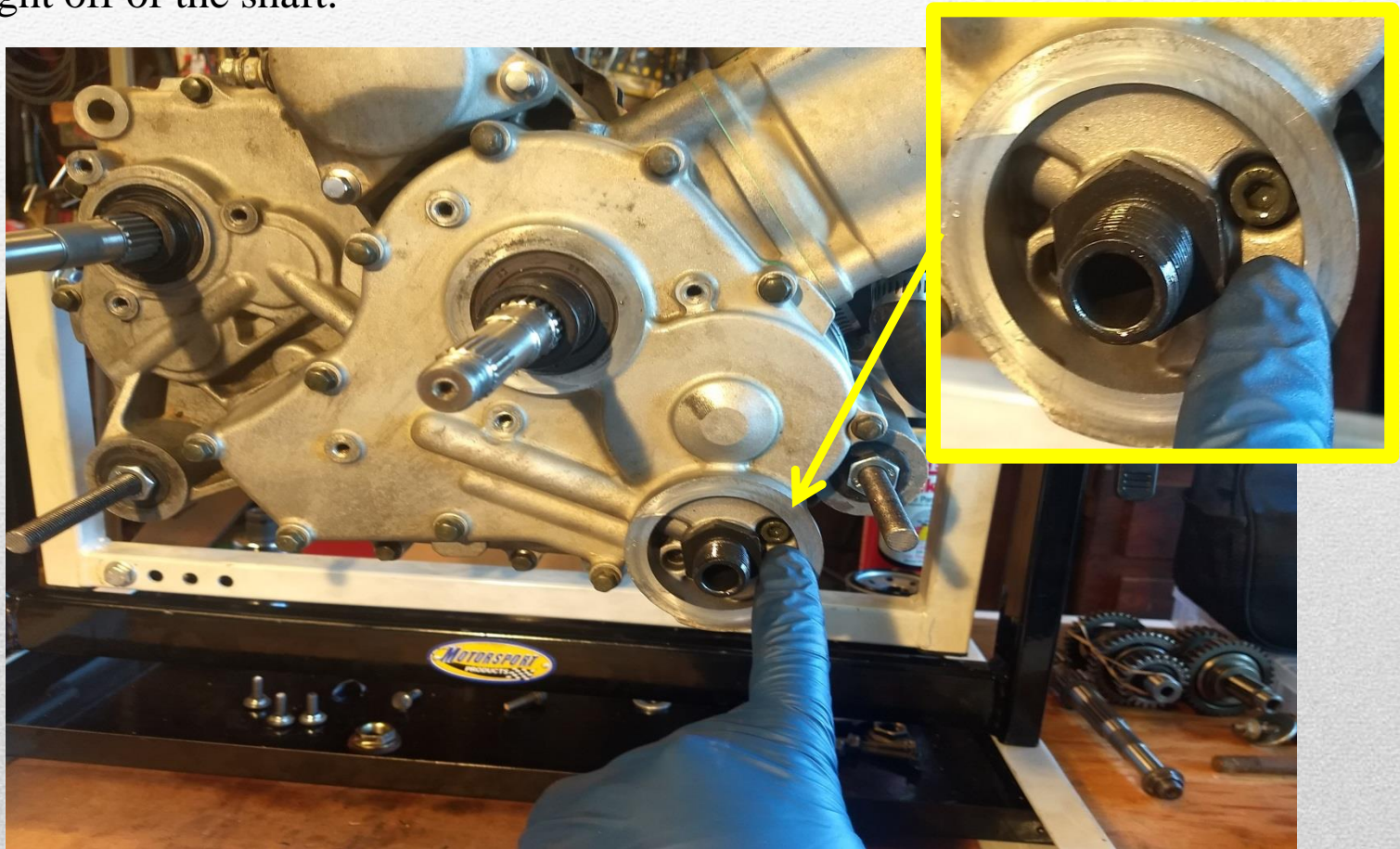

With right side cover removed.

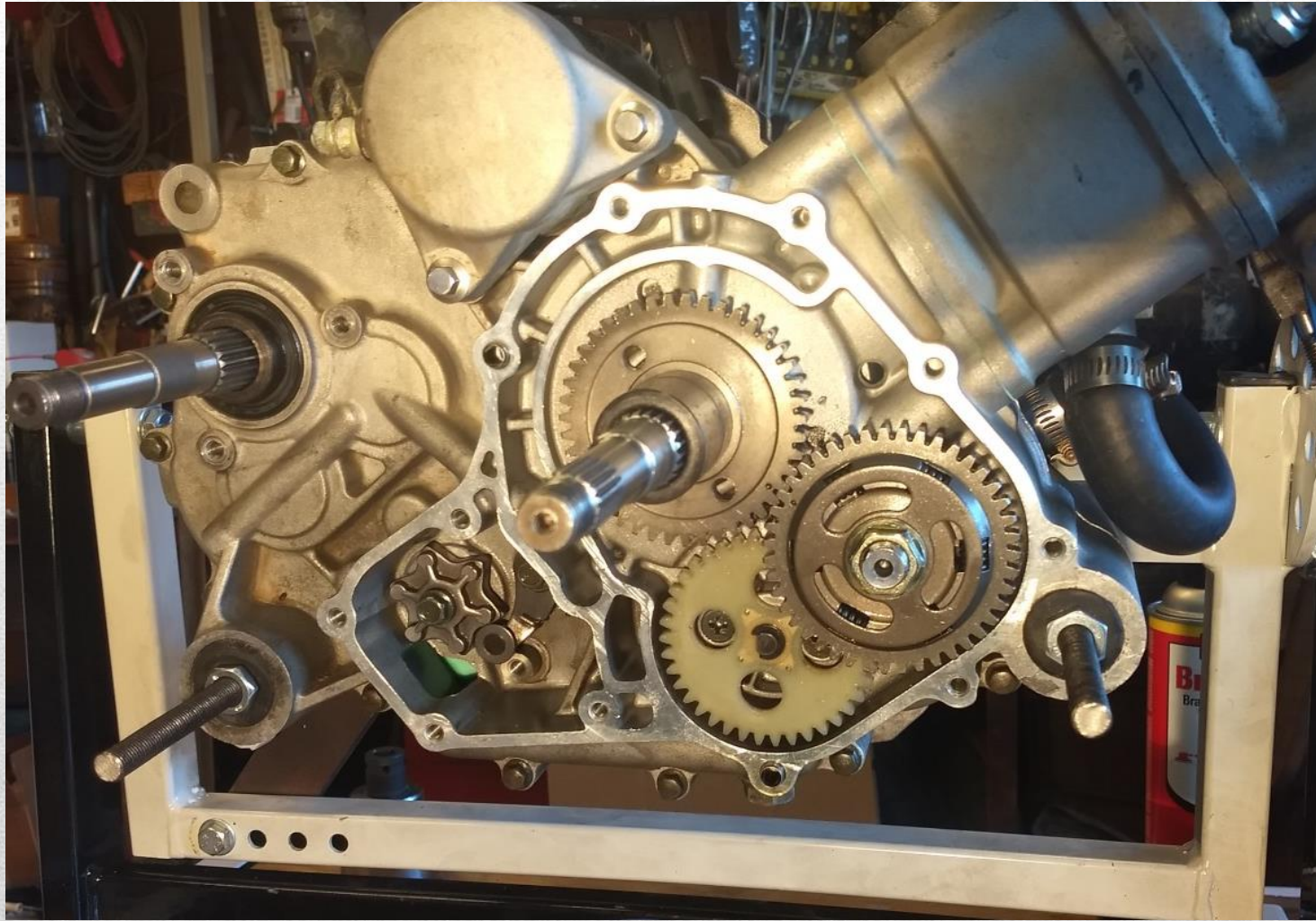

Here is the timing mark for the crank and counter balance shaft. Ensure these marks line up when re-installing the parts. Failure to do so can cause engine running problems and possibly engine failure.

Timing marks

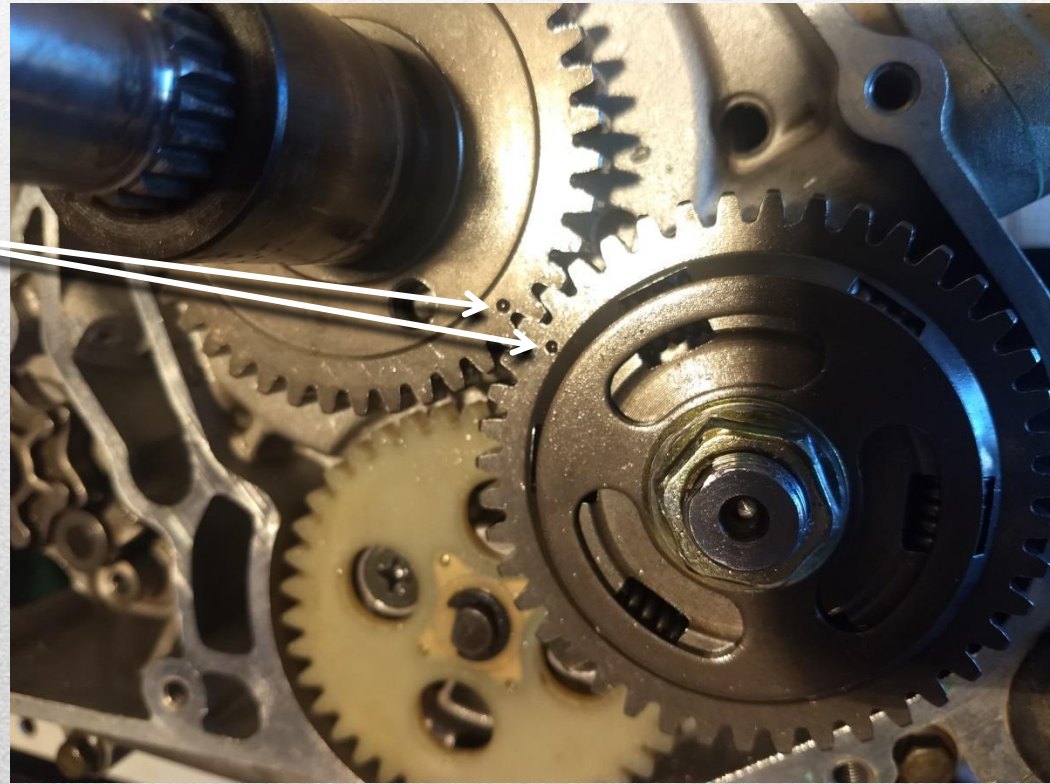

To remove the left side cover, start by removing the bolt and washer on the shift shaft. (c) This bolt and washer will prevent the side cover from fully being removed and possibly damage the seal.

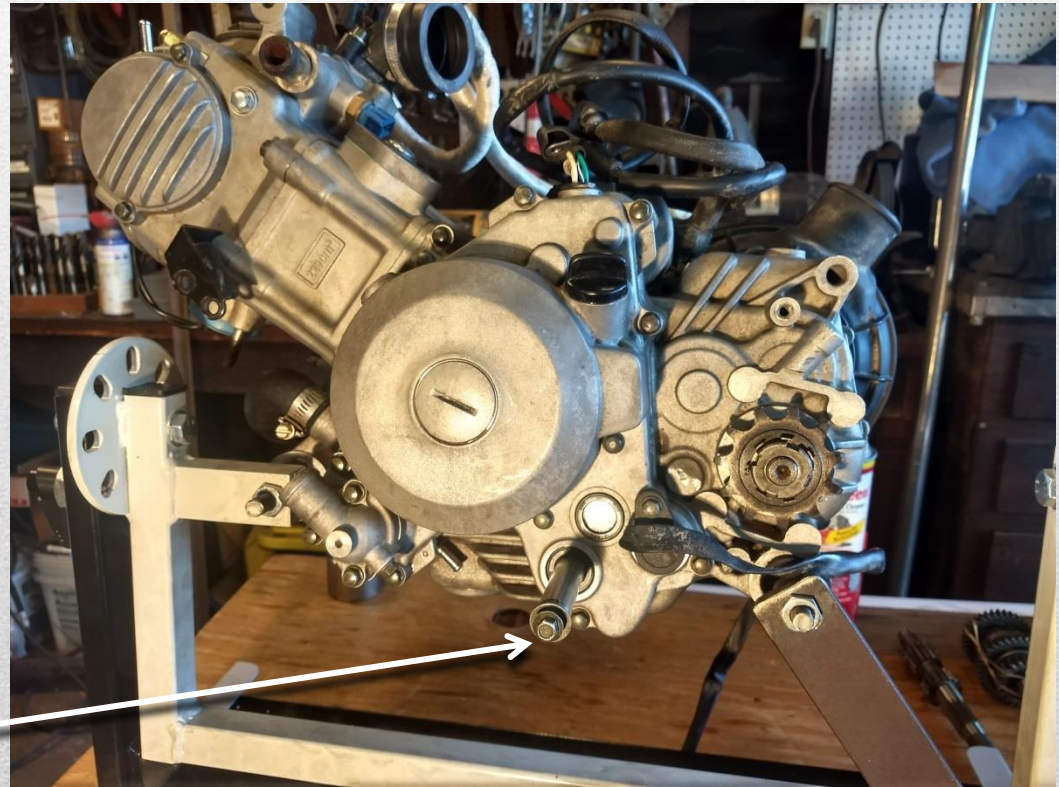

(c)

Locate the shift indicator switch on the left side cover. Remove the 8mm bolt and slide the switch out of the hole



Inspect the switch for corrosion and or damage. If the contacts appear dirty, clean them with some 3M scotchbrite pads lightly.



Inside you will find a metal pin. This contacts the switch and tells the computer what gear the UTV is in



Pull the switch tab out of the hole and set aside. Take note to see the tab on the side of the pin and the slot on the shift drum



When removing the left side cover, it is **not** necessary to remove this bolt. It is a coolant bleed hole and has an aluminum washer behind it.

In this photo, the thermostat cover has been removed, but it is also not necessary to remove the side cover.

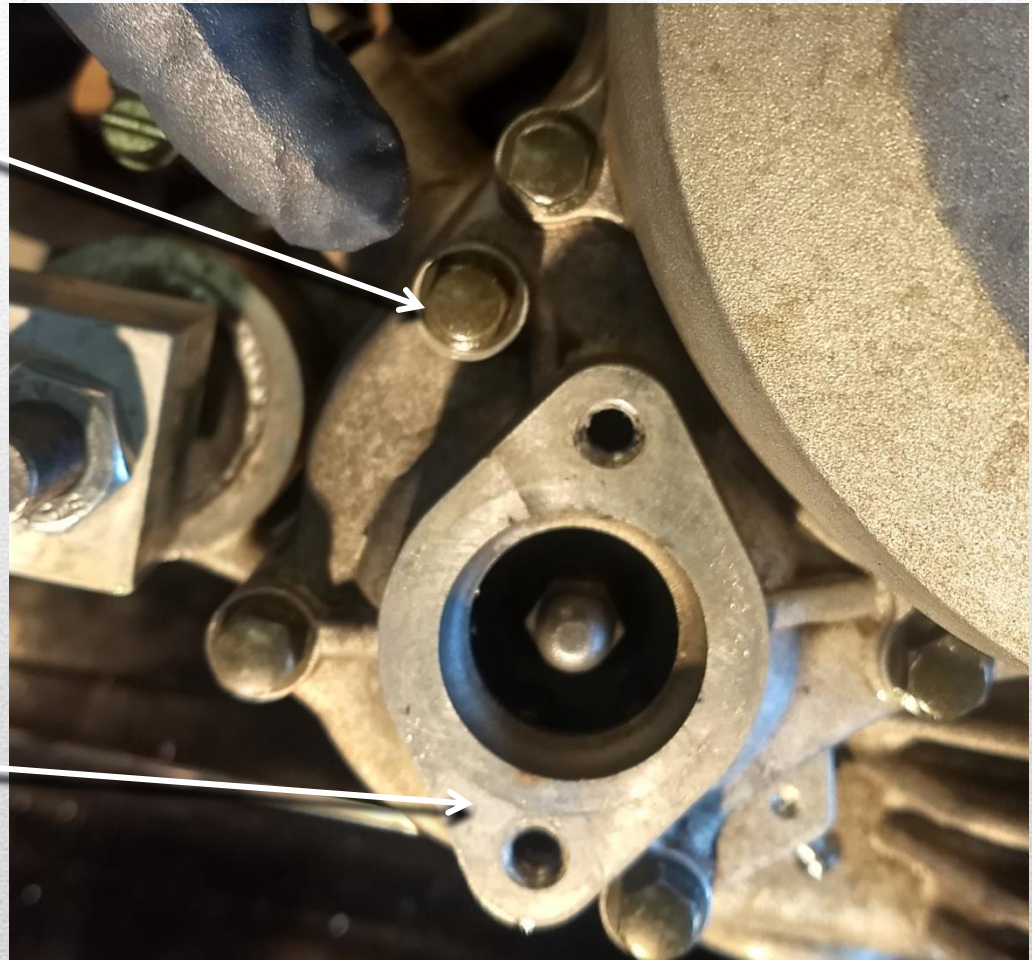

With the left side cover removed you can see the flywheel, water pump and shift shaft.

Flywheel

Water pump

To remove the flywheel, you will need a puller so that you will not damage the case or flywheel during removal.

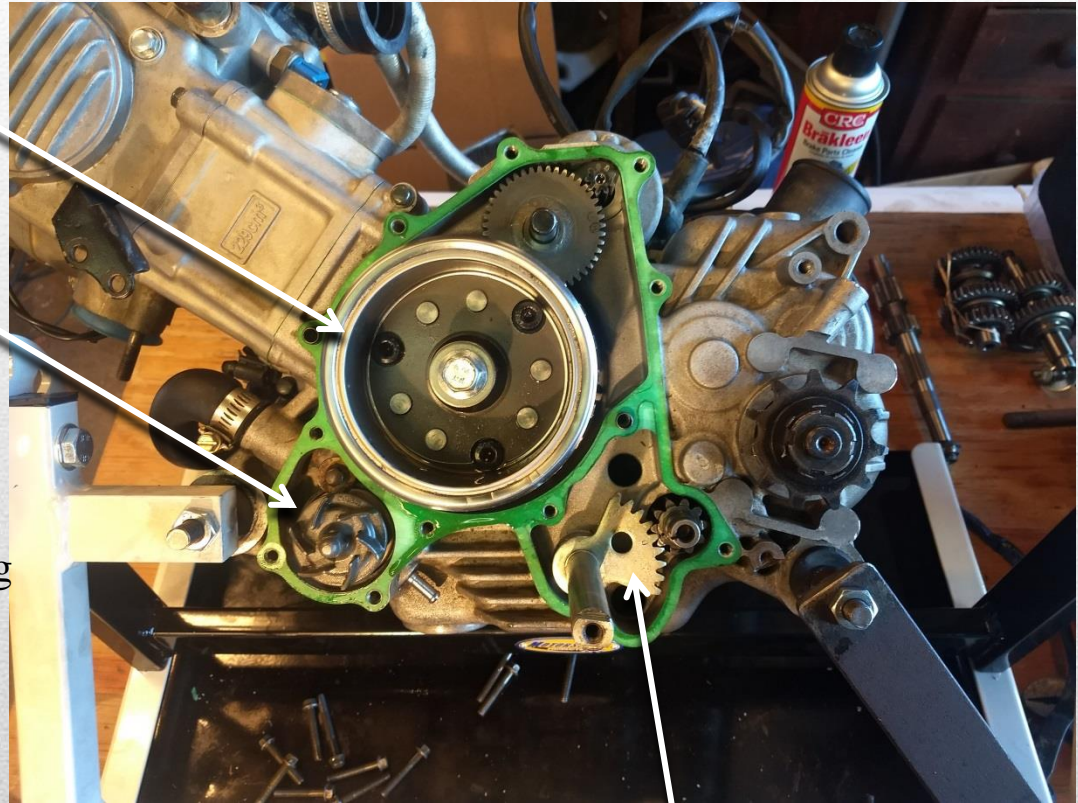

Shift Shaft

The shift shaft and the shift drum have alignment marks on each of them. Make sure they are properly aligned when re-assembling to ensure correct shifting.



With the flywheel removed you can see the proper way the starter gear and starter idler gear are placed.

Starter Idler
Gear

Starter Gear

Water pump

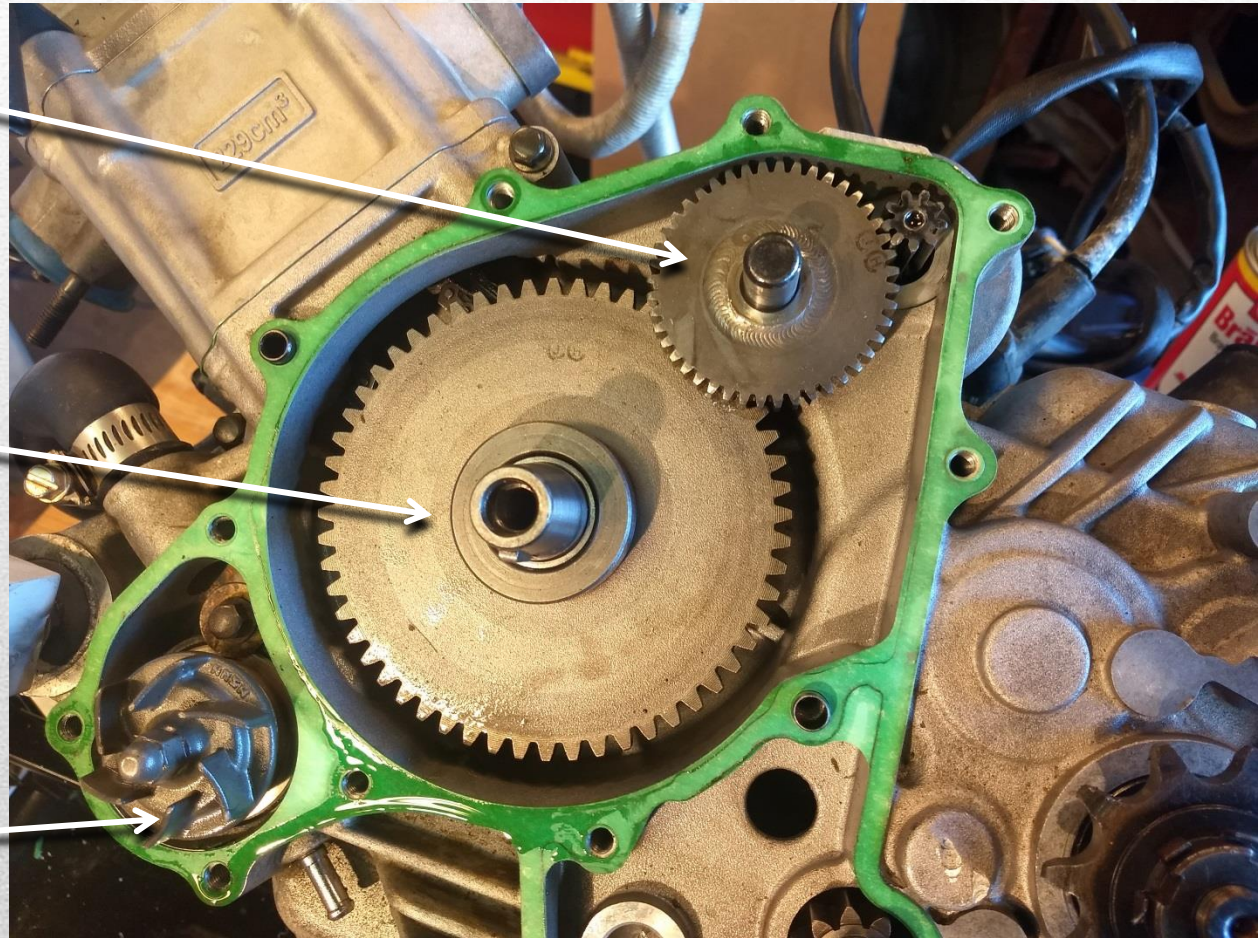

Pull the starter gear and starter idler gear out and place aside. Next is to remove the countershaft sprocket. Using a special socket.

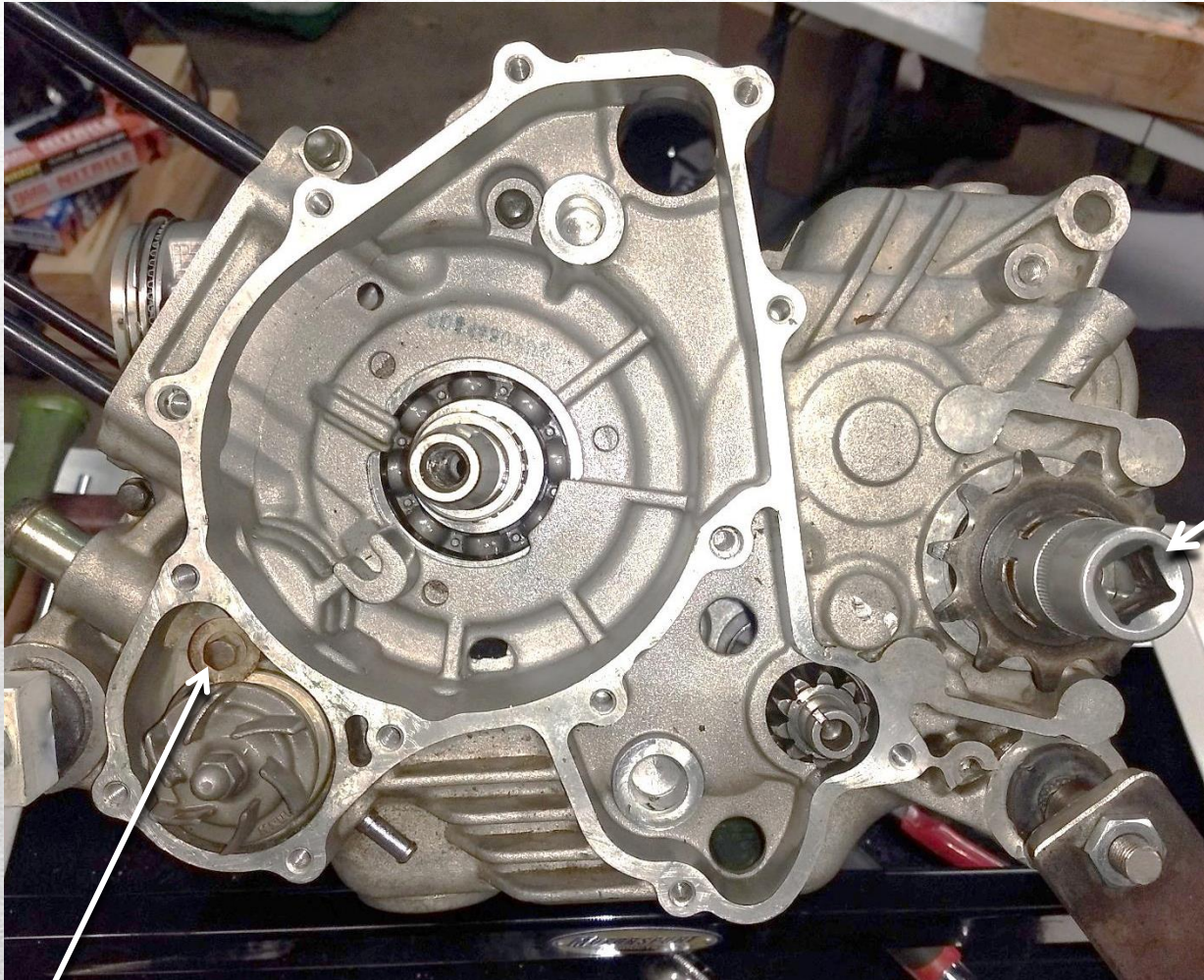

EXAMPLE TOOL



The special tool needed to remove the OEM nut is 20mm Lock nut spanner wrench, available online or at our website. You can use a punch to remove it as well.

Note: to remove the water pump, remove the 8mm bolt on top of the water pump and pull the water pump outwards. It might be tight due to worn O rings. You do not need to remove this for the engine rebuild. It can stay in place.

On the right side of the engine, locate and remove the 19mm nut to the countershaft balance drive gear. Remove the gear and watch out for a small retaining key way securing the gear to the shaft. After removing the gear assembly, slide the balance drive gear located on the crank shaft off.

Balance drive gear

Countershaft balance gear

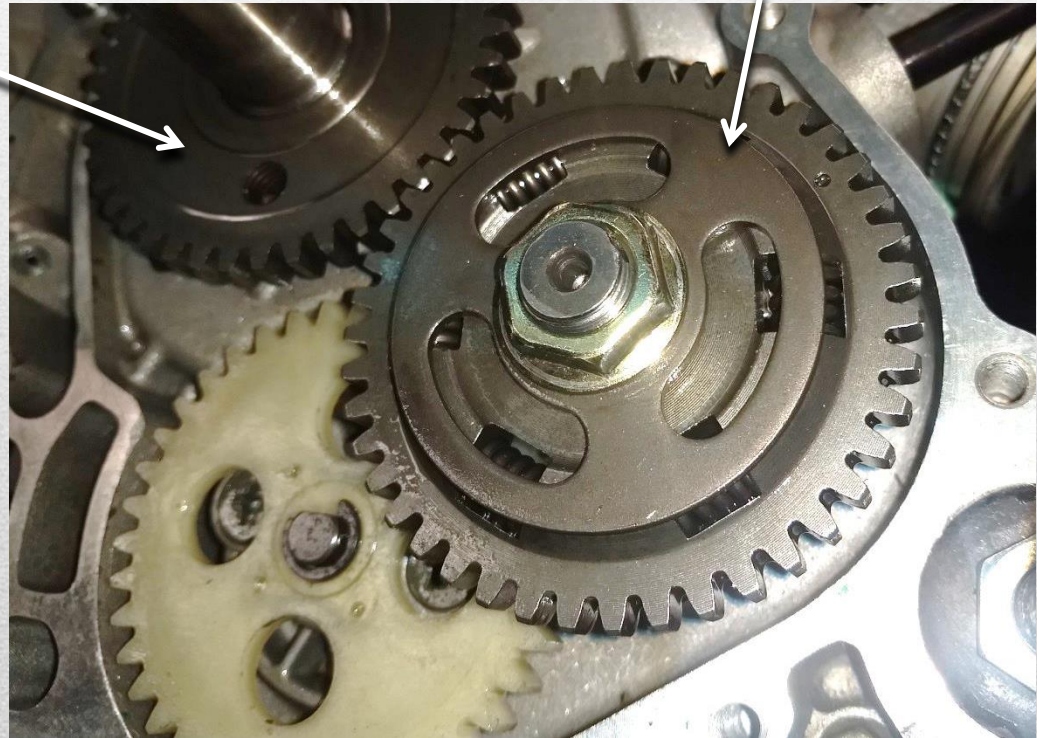

Next is to remove the oil pump. You will need to use a impact driver tool to assist without damaging the 2 screws.

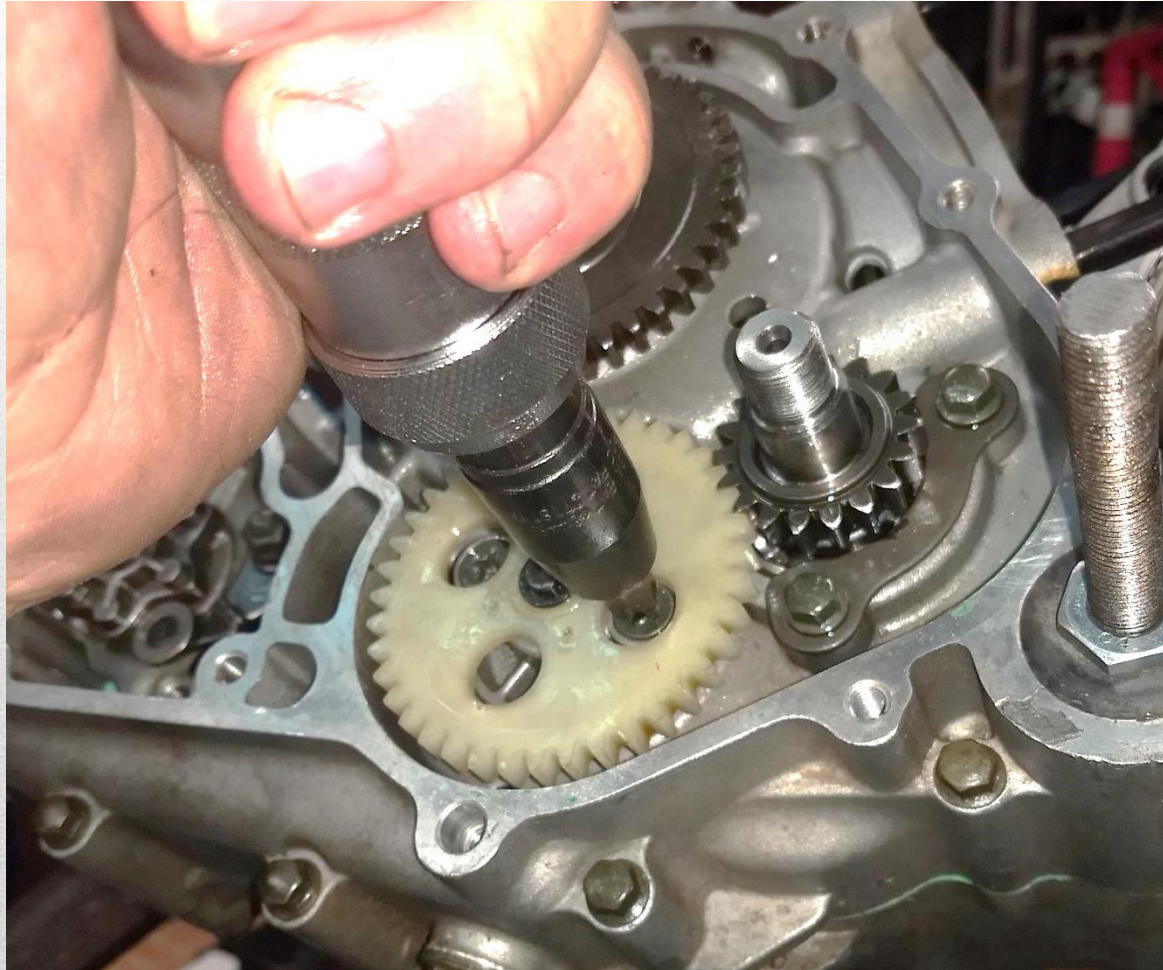

Next remove the shift drum detent and shift paw.

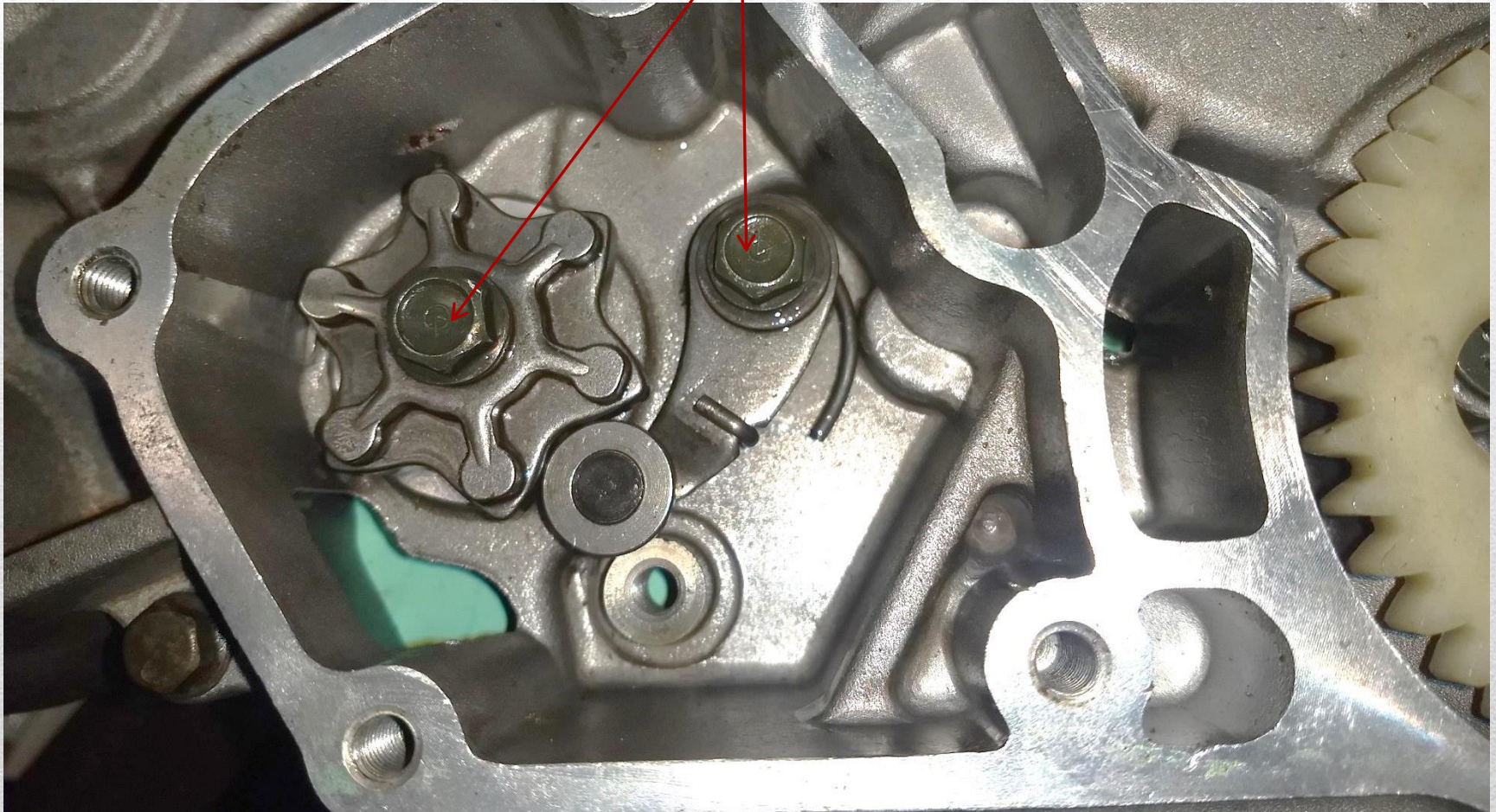

Removing the cylinder head

- Remove the 4 bolts holding the cylinder head cap.
- Remove the 2 smaller 10mm bolts on the left side of the cylinder head
- Remove the 2 valve adjustment caps
- Loosen the valve adjustments a little to ease removal and installation of the cam.



Remove the side cover on the cylinder head to access the cam gear and timing chain. Remove the cam chain tensioner first, then remove the 2 bolts holding the cam gear to the cam. Then move the gear out and place aside. Try to hold the cam chain secure with wire or another means to prevent it from falling into the engine.

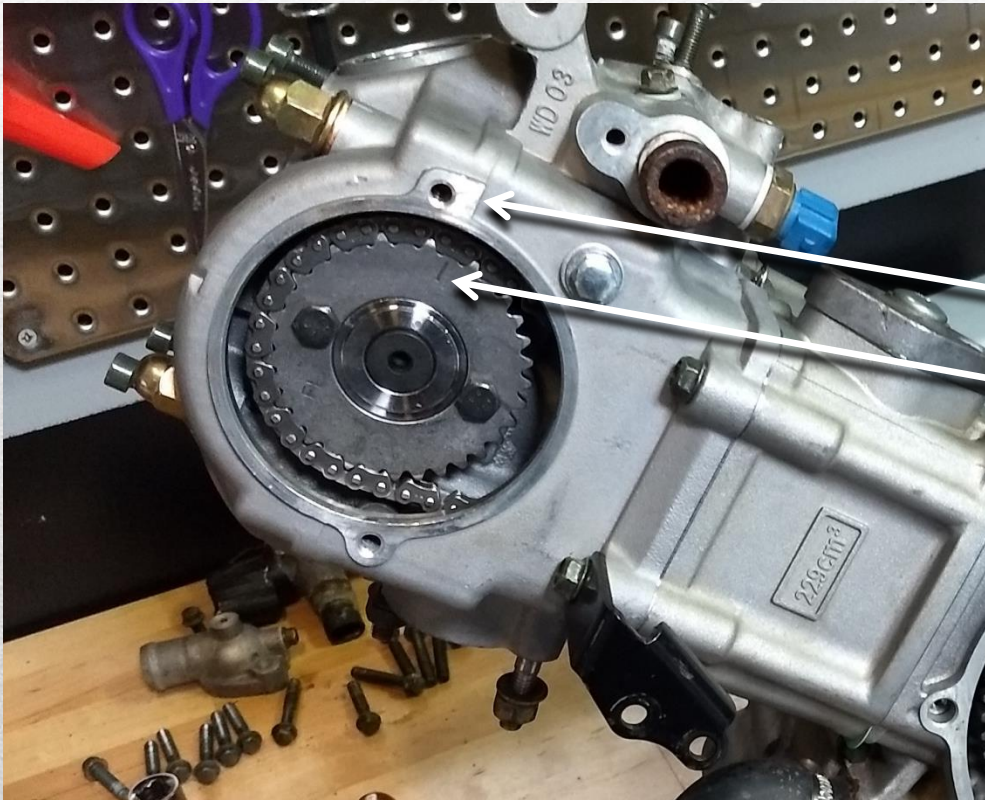

Cam chain tensioner



In this photo you can also see the cam timing marks on the cam gear. They are aligned with the mark on the cylinder head.



Remove the 4 cylinder head nuts in this pattern to prevent the cylinder head from warping. ***Do not re-use the copper washers, always replace them.*** Remove the nuts in the pattern below. When reinstalling the cylinder head, tighten them in the same order as below to prevent warping the head.

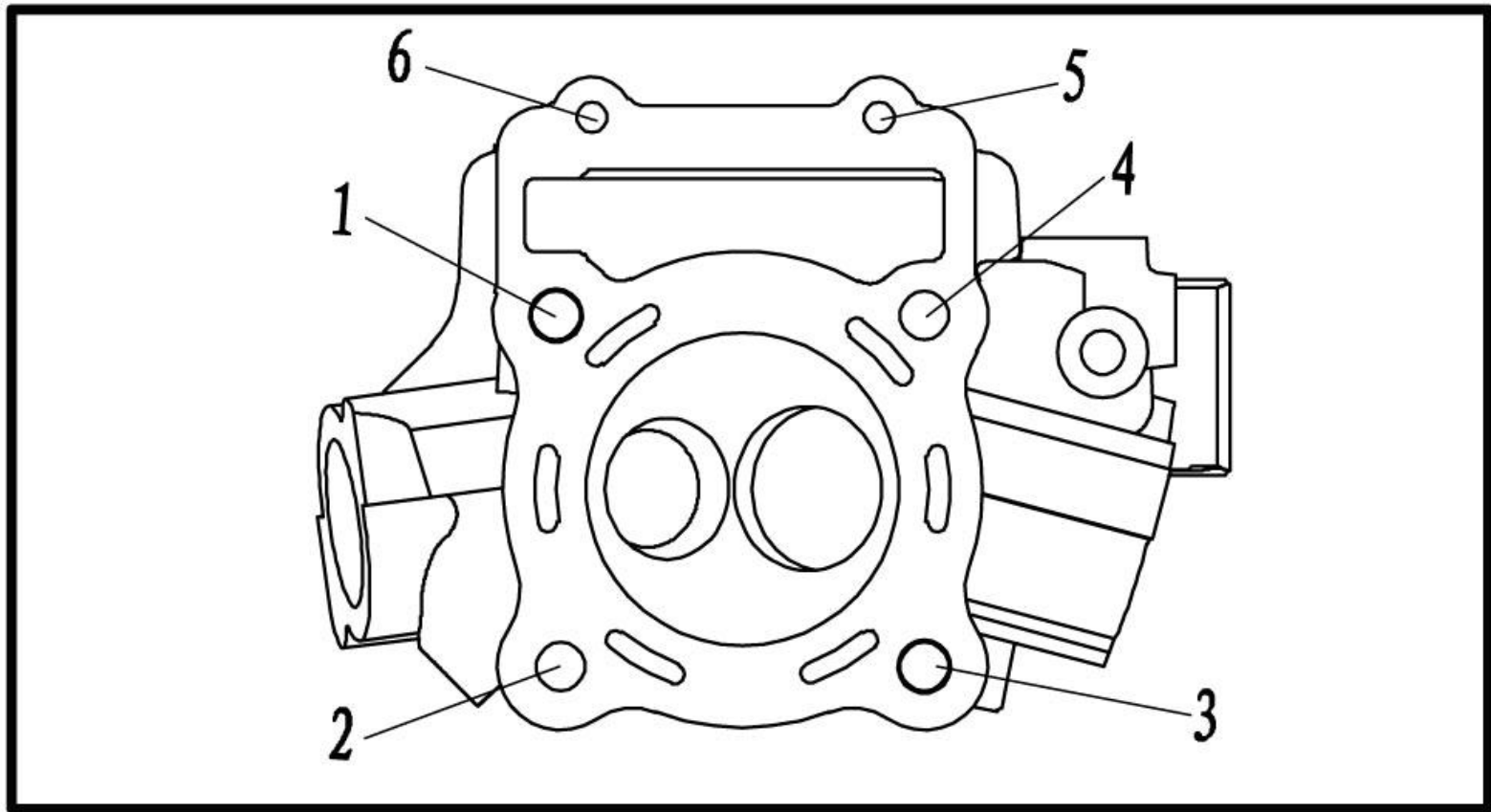

View of the cylinder head with the cover removed and the head nuts removed. *Always use new copper washers when installing the head.*

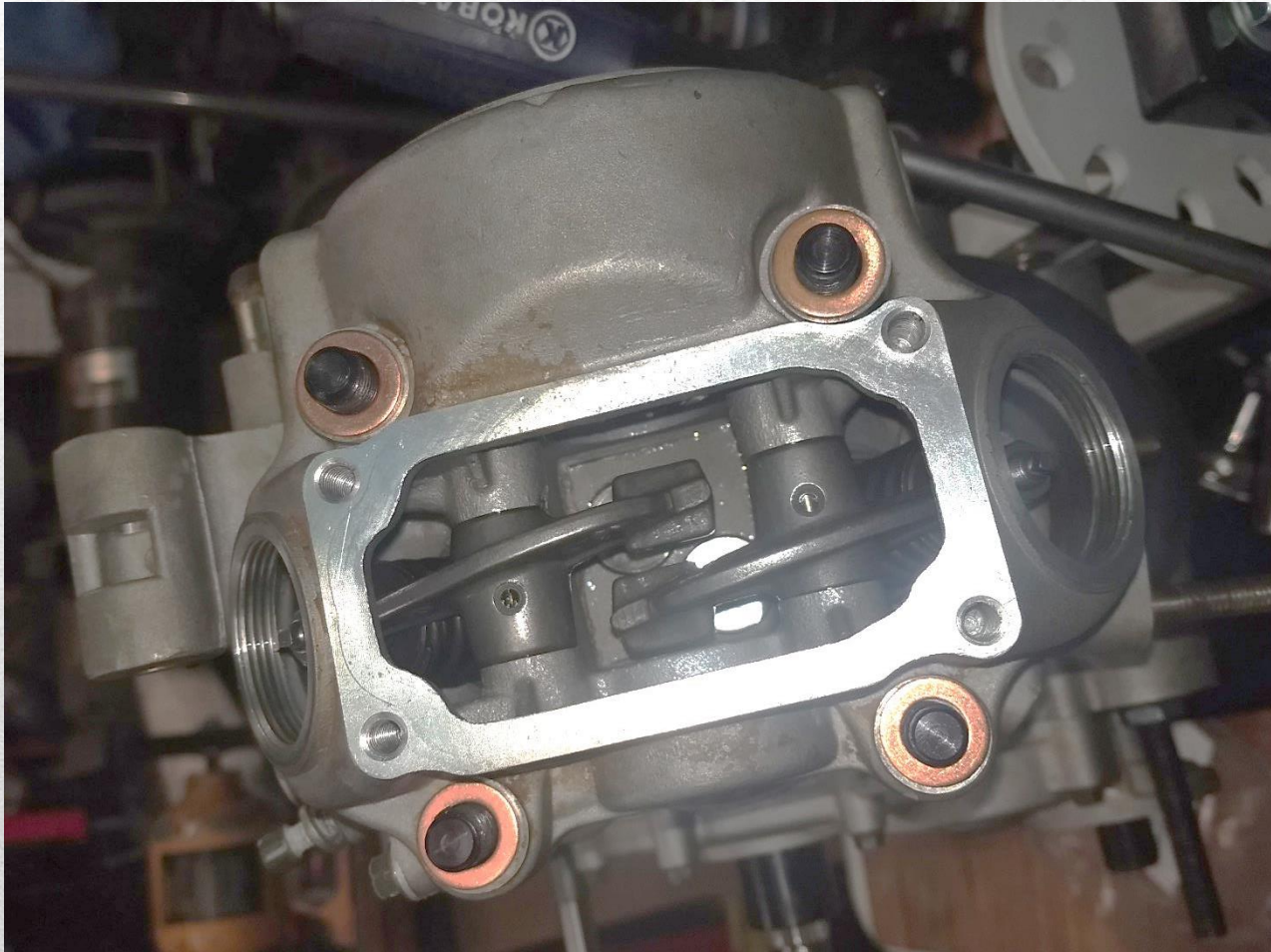

Here you can see the cam retaining plate. The rocker shafts are installed so that the flat side to the shafts rest against the retaining plate, securing them in place. Remove the bolt holding the plate in place. You can now remove the cam if the rocker adjustments are loose enough.

Note: removal of the cam is not necessary for engine tear down. Only if you have to service the cylinder head.

Installation is in the reverse order. Install the cam and then the cam retaining plate. Making sure the ends are aligned with the rocker shafts as in the pic here.

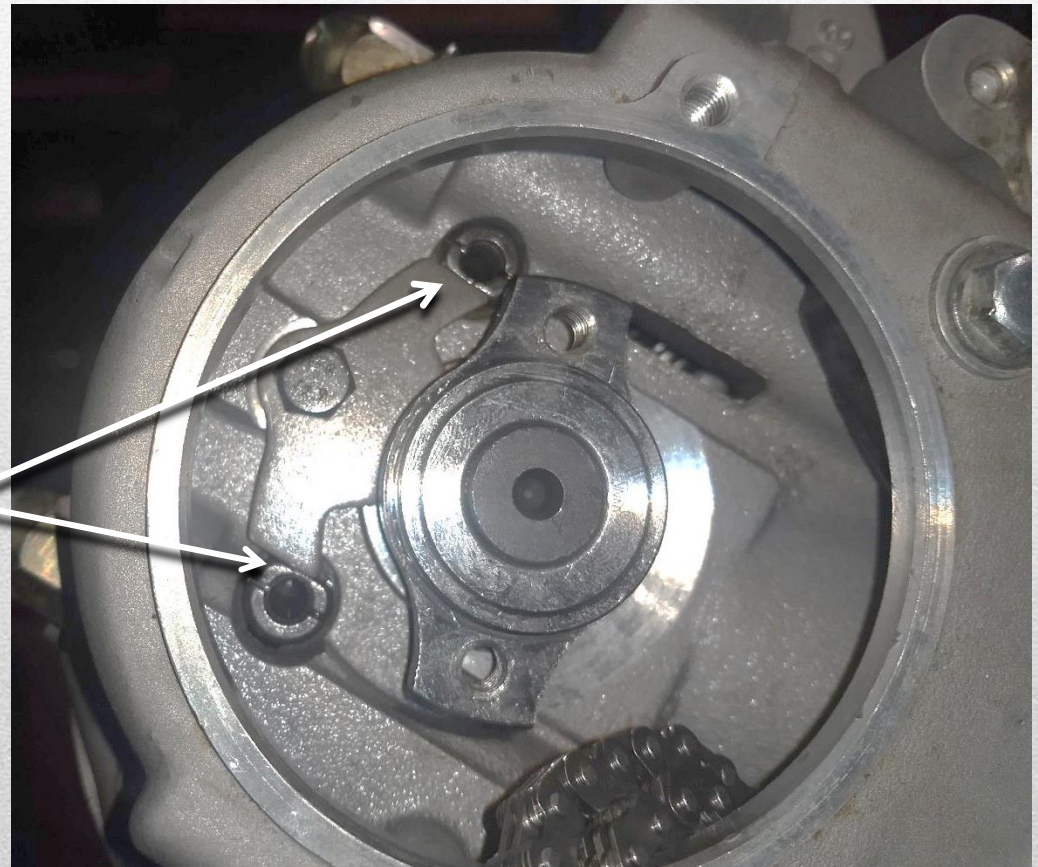

Inspection port for valve adjustments.

Valve clearance (cold)

Intake

0.08 ~ 0.12 mm

(0.0031 ~ 0.0047 in)

Exhaust

0.10 ~ 0.14 mm

(0.0047 ~ 0.0063 in)



With the cylinder head pulled off, you can slide the cylinder up and off. Next is to remove the cam chain off the crank gear.



CLYINDER BODY

CAM CHAIN GUIDE

ENGINE CASE SEPARATION



CASE SPLITTER TOOL (I got mine from factory wrench tools)

www.factorywrenchtools.com

To prepare for the engine case separation, there are 3 bolts located on the **left** side of the engine. They must be removed before the cases will part.

It is also recommended to use a case splitter to perform this task, as the crank bearings tend to be tight in the case halves. It can be done without this tool, but use care not to damage the cases when splitting.

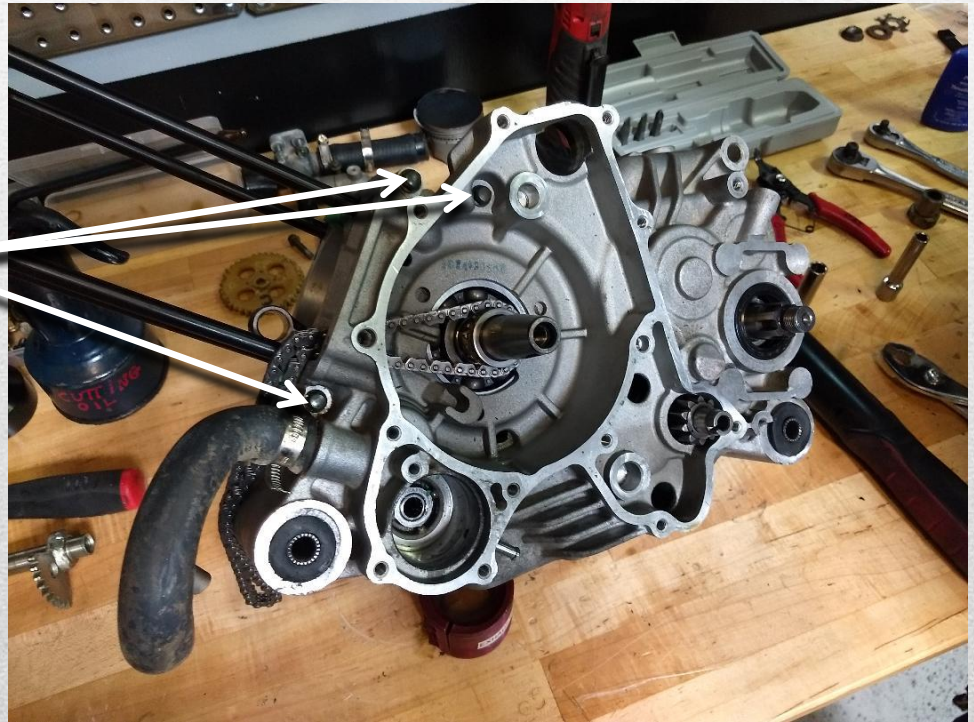

On the right side of the engine, remove the remaining 8mm bolts that connect the case halves together.

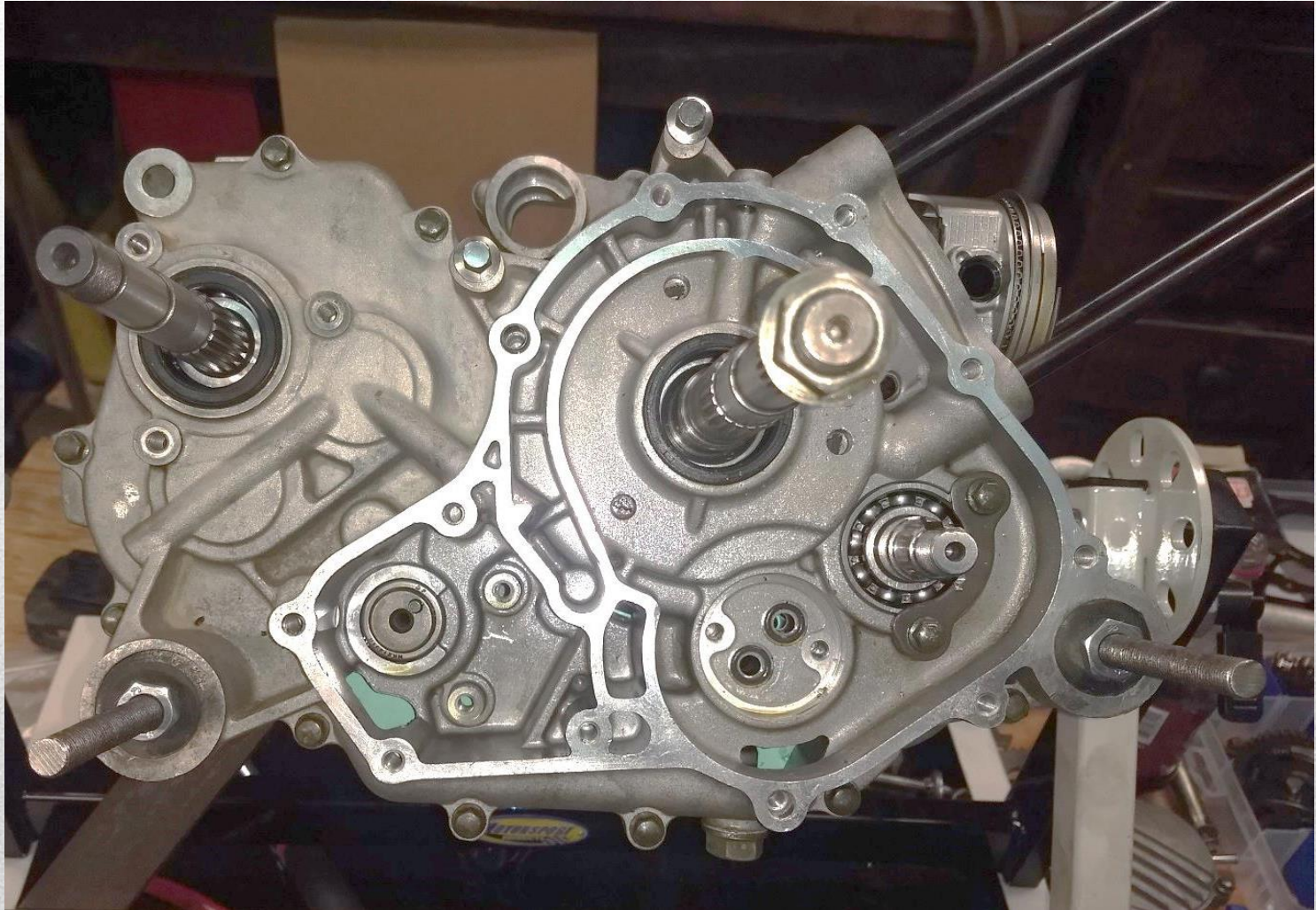

INTERNAL ENGINE COMPONENTS

COUNTERSHAFT

CRANKSHAFT

MAIN SHAFT

OUTPUT SHAFT

SHIFT FORKS

SHIFT DRUM

COUNTER BALANCER

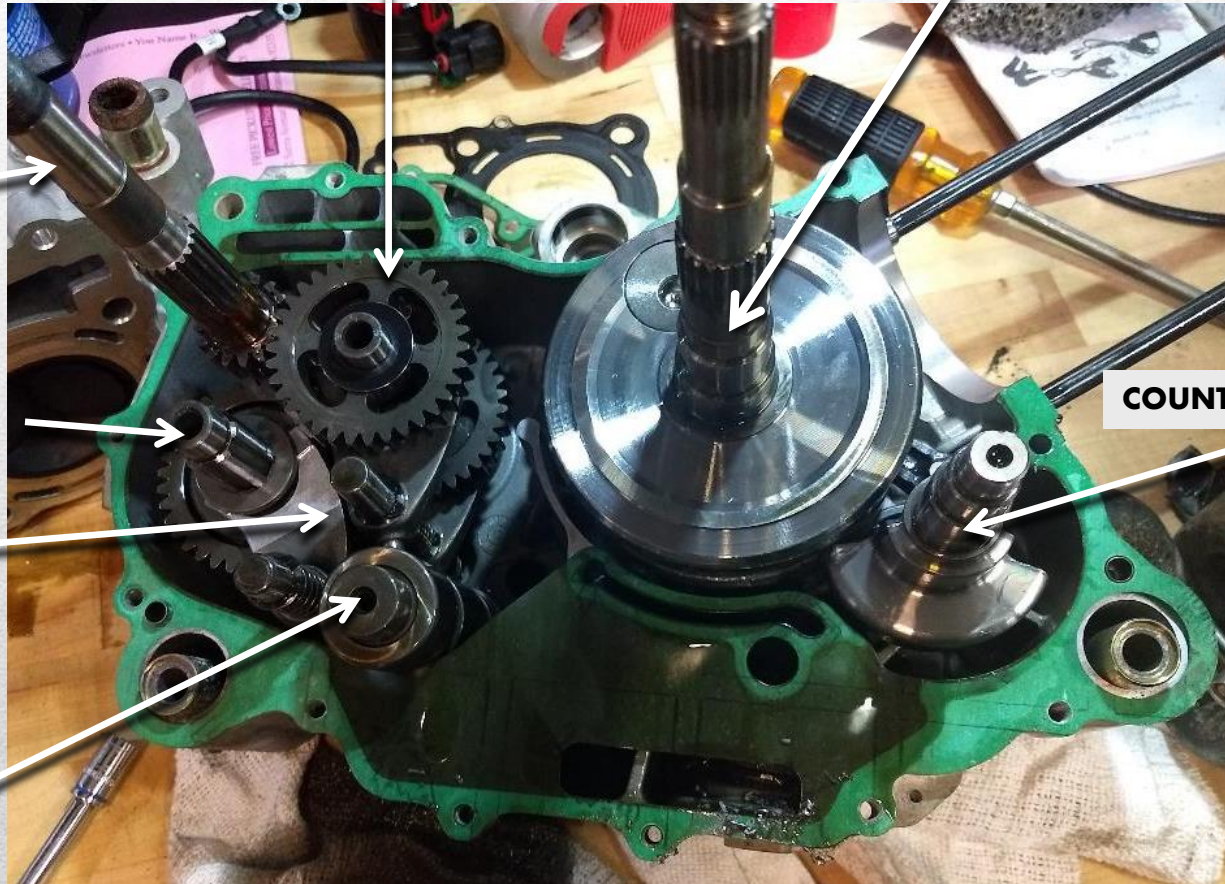

LEFT SIDE ENGINE CASE

RIGHT CASE HALF



LEFT CASE HALF

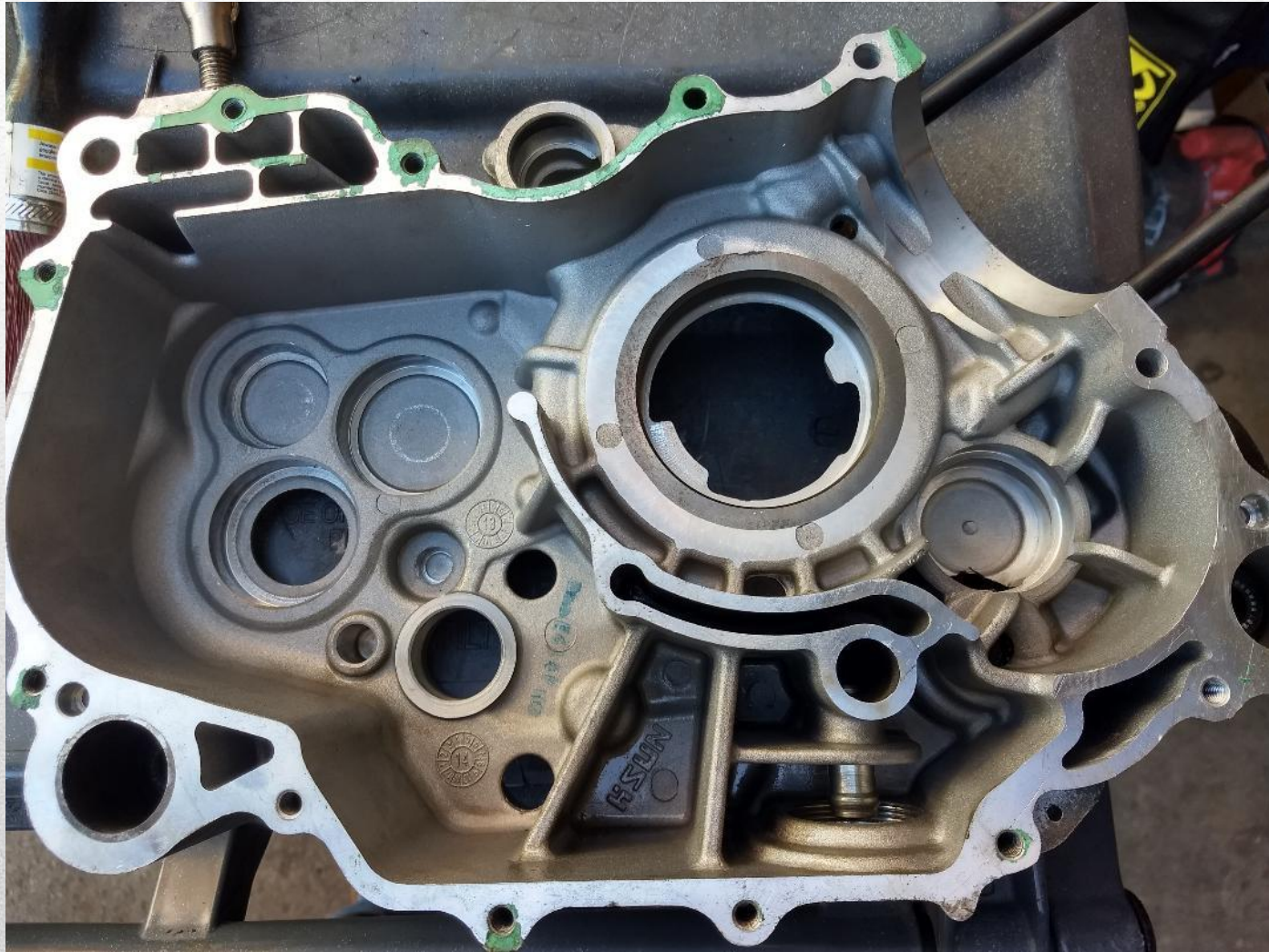

TRANSMISSION REBUILD KIT FOR 250cc



Installation of the countershaft gear assembly with the shift forks as a whole. This will make installation easier than trying to install each separately.



Installation can be tricky, try to install the transmission parts as complete as possible for alignment issues. The main shaft can be installed last as it has no alignment problem.

With the transmission installed it should look like this. Ensure to put some lube on the transmission prior to sealing the case halves together to prevent dry start up.

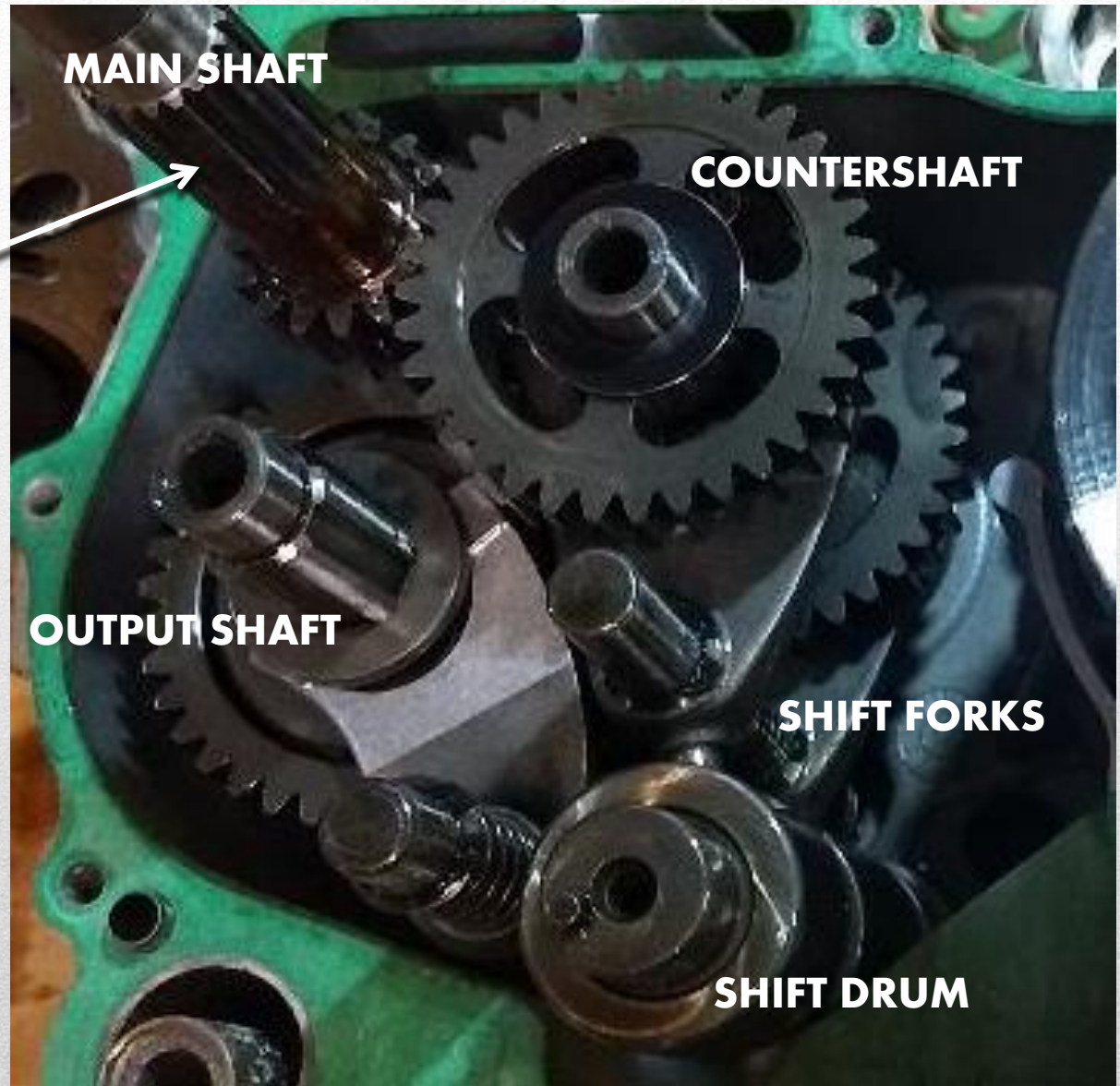

Installation of the transmission is a little tricky. The countershaft assembly and the output shaft need to be installed along with the shift forks at the same time to make installation simple. It can be done separate but might take some time to align the gears. *We have a video on our website to show how to correctly install the transmission. As well as on YouTube: Hisun 250 Transmission installation.*

Take note on the correct installation of the shift forks, as the pins on the shift forks need to look like this in order to align with the shift drum when installing. The shift drum installs with the gear side facing the left engine case.

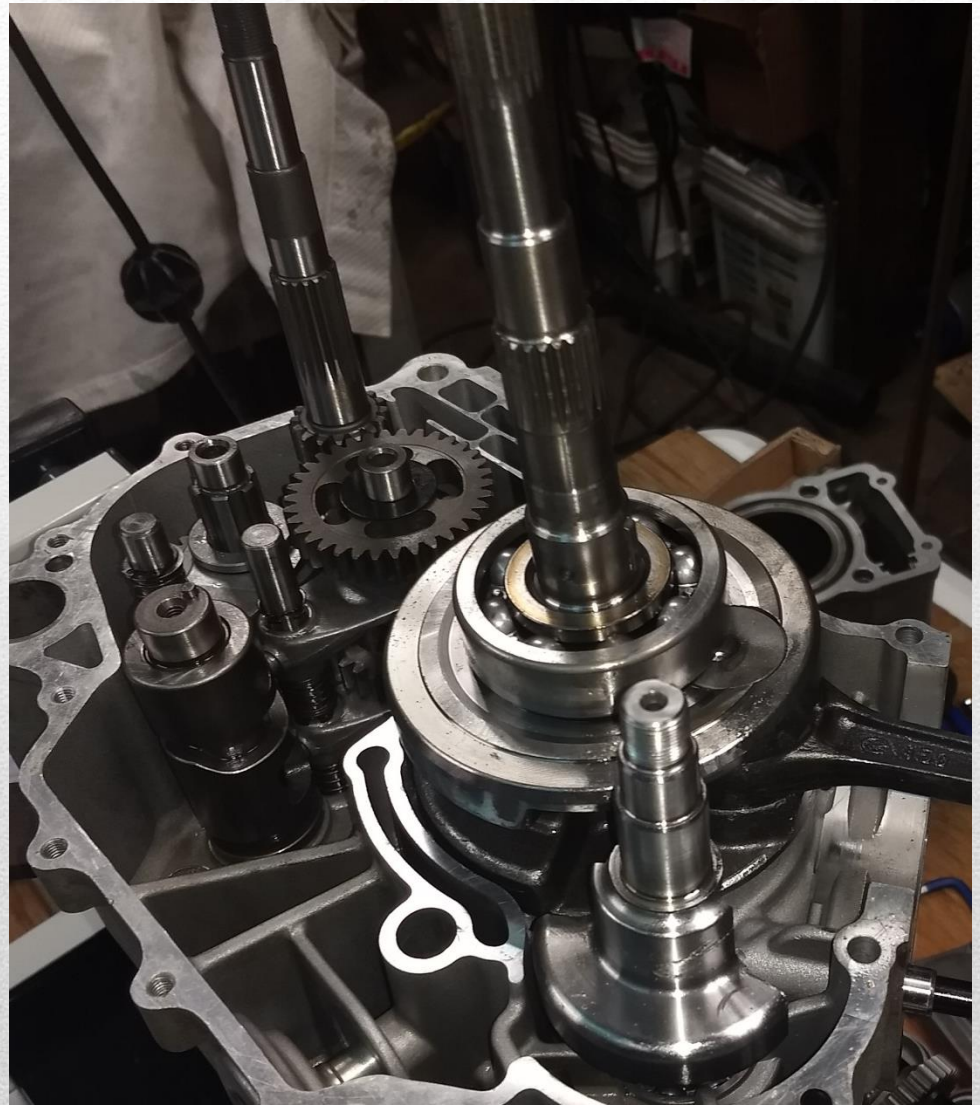

OIL PUMP P/N 15100-013-0000

Inspect the oil pump and replace if there is any question to the quality. When you are rebuilding an engine due to a “blown up” transmission, small metal particles might end up in the pump causing damage later.

If you are doing a simple engine rebuild, then inspect the oil pump and re-use if it is working properly. It is recommended to replace the 2 O rings sealing it to the engine case.



Install the balance gear on the crankshaft at this point. With the shoulder side facing the engine. Ensure the key way is installed as well

Install the oil pump making sure the 2 O rings are in place. Use an impact driver to secure the 2 screws.

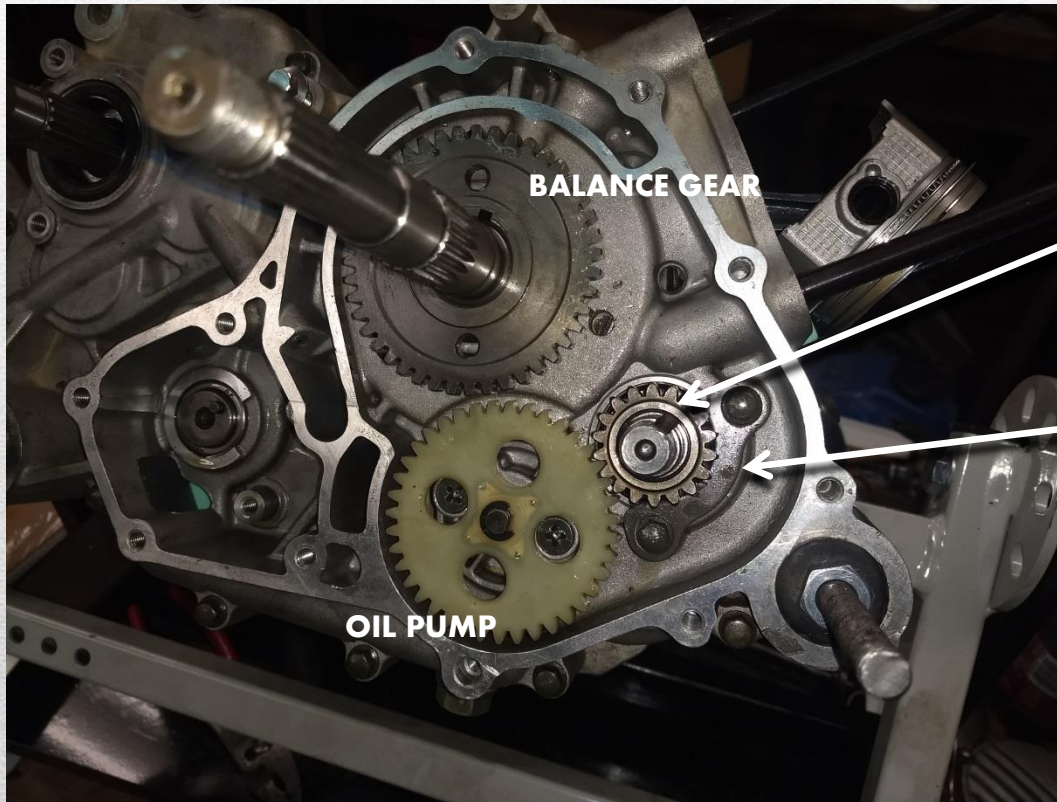

Install the oil pump drive gear if it has been removed.

Make sure the bearing retaining place is in place with the 2 bolts.

Install the shift drum index gear first, making sure to line up the pin to the back of the gear.

Next is to install the shift position plate assembly. Making sure the spring is pushed down against the case and behind the round case extension area.

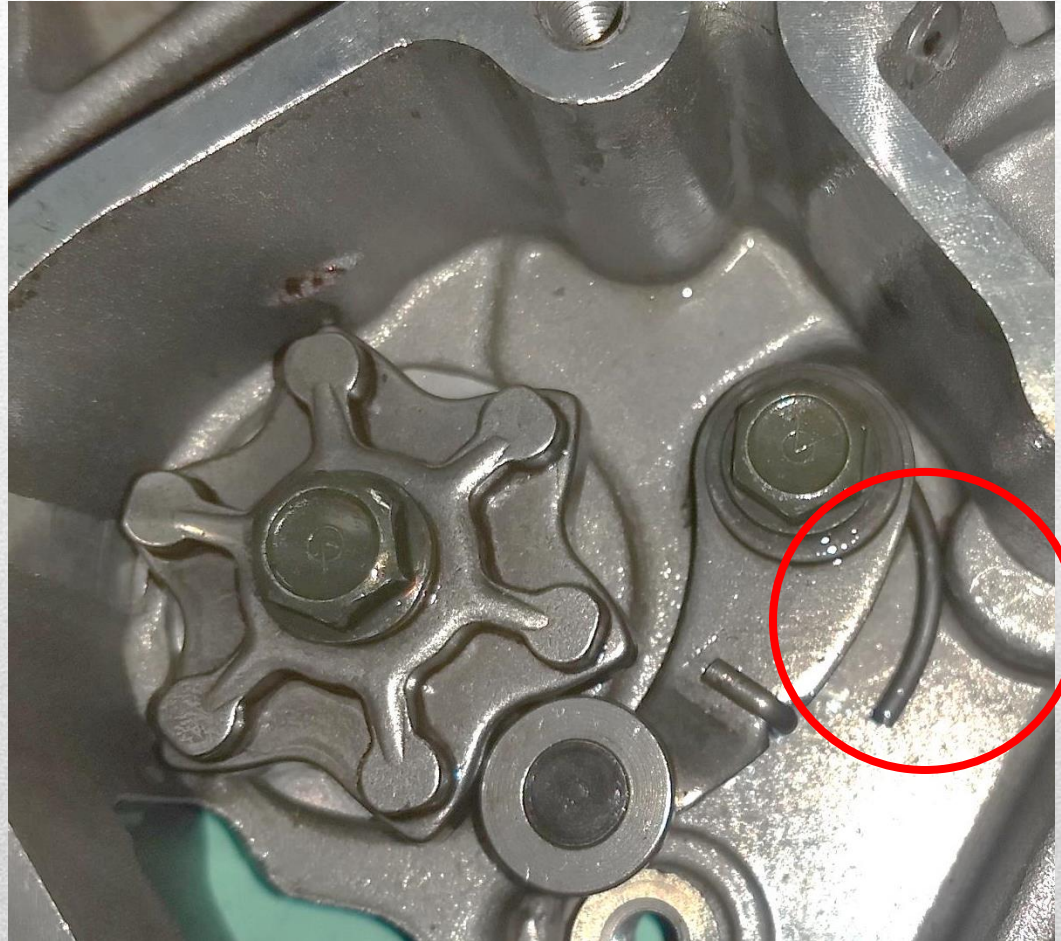

Install the cam chain on the crankshaft gear on the left side of the engine. Pull the chain through the opening in the case half.

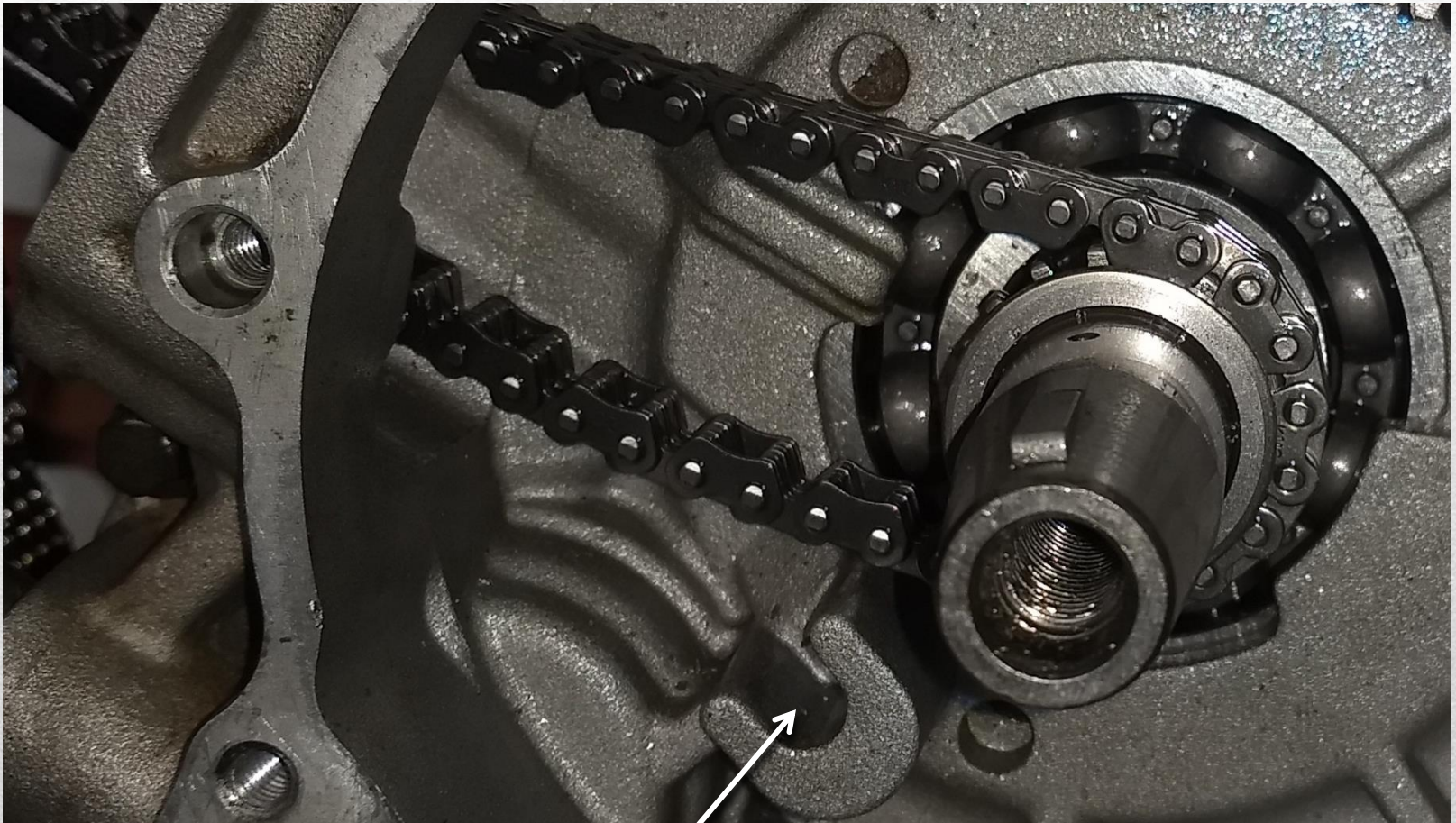

CAM CHAIN GUIDE POCKET

Install the starter disk gear assembly. (the large one) with the shoulder facing outwards.

Install the starter idler gear with the small gear facing towards the engine as in the photo.

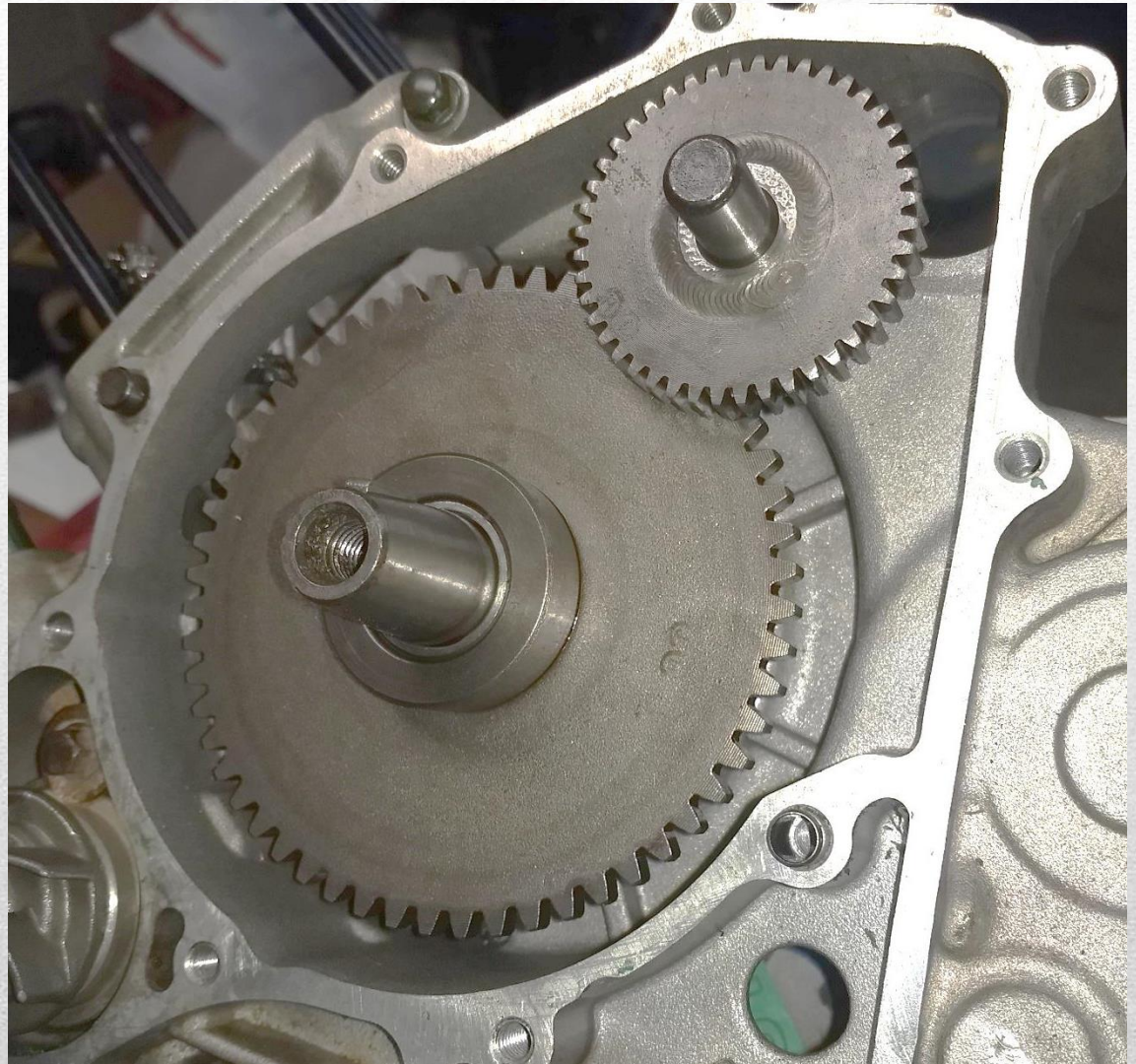

Install the fan shift gear assembly. (shift rod) into the case as in the picture below. Making sure the mark on the shaft aligns with the dot on the shift drum.

Alignment marks

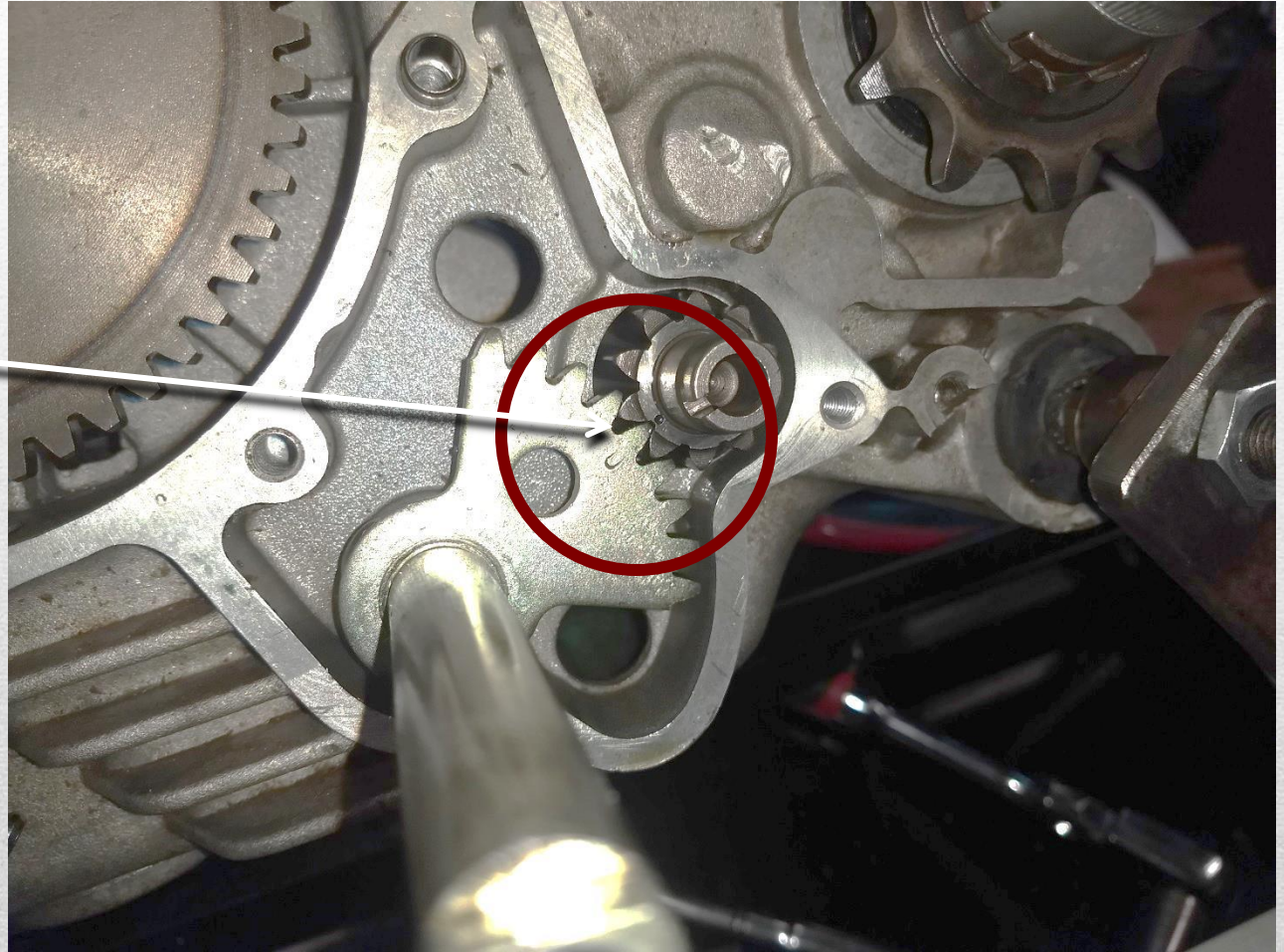

1. Install the locking plate balance gear against the gear on the balance shaft

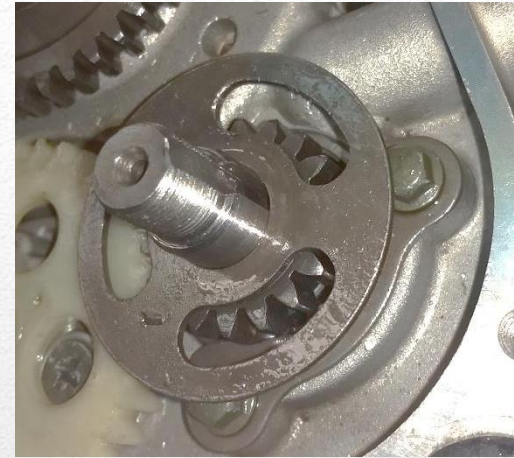

2. Install the balance drive gear assembly next making sure to install the key way here.



3. Install the outer locking plate balance gear and torque the 19mm nut down to 61 ft. lbs

Ensure the timing marks on the crankshaft gear align with the mark on the balance shaft gear as in the photo below.



Re-install the right side cover and torque down the 8mm bolts to 9 ft. lbs.

At this point you can install the spacers on the crankshaft and main shaft. Making sure the side with the O rings is facing the engine. The two are not the same. The shorter one goes on the main shaft, and the longer ones goes on the crankshaft.



Install the magneto rotor making sure the key way is installed. Torque down the bolt to 40 ft. lbs.

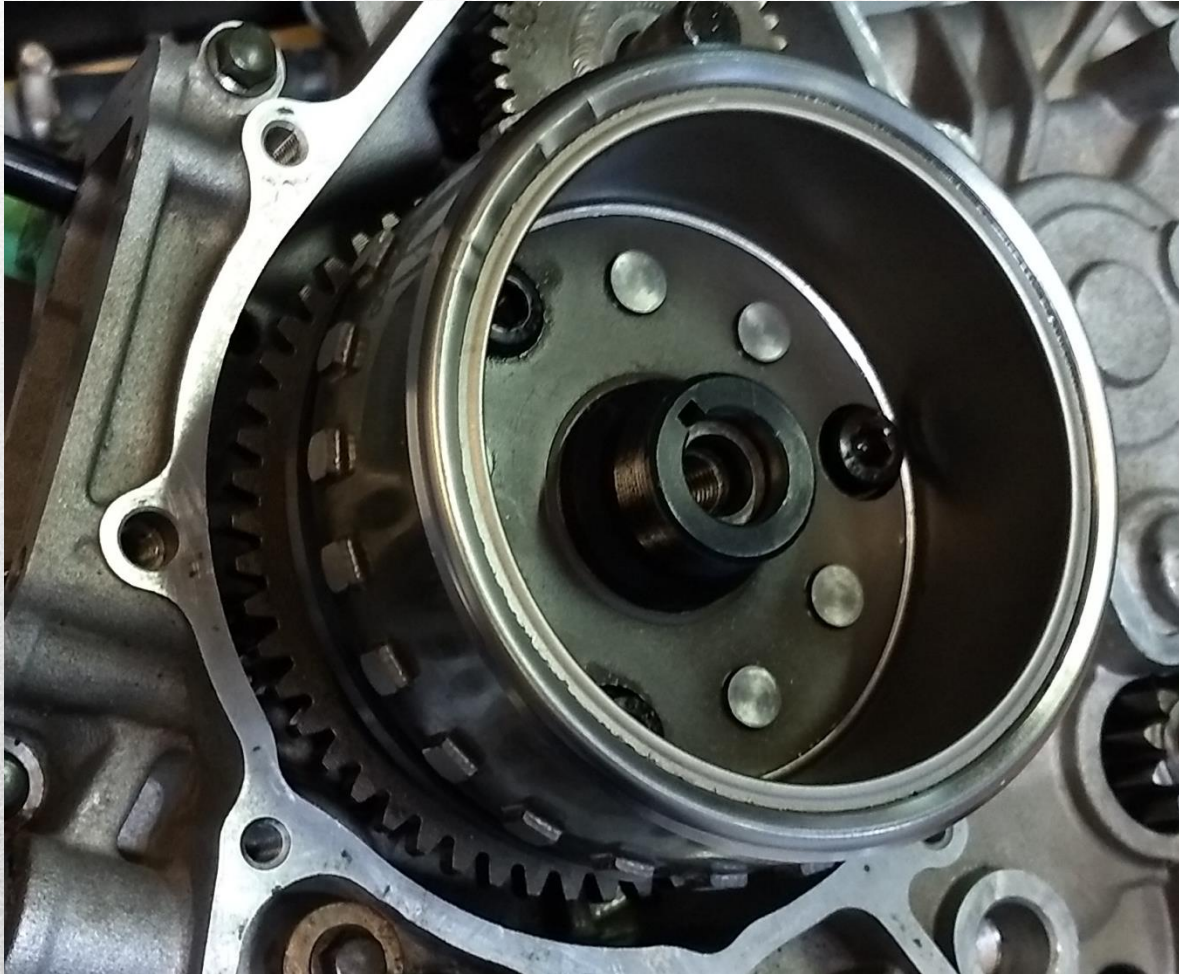

Install the left side magneto cover at this time. Torque the 8mm bolts down to 9 ft. lbs.

Timing mark port

Port to turn the
crankshaft to check
timing marks

Installation of the shift
indicator switch is in
reverse as removal earlier
in the guide.



Install the cylinder head using new base gasket. Guide the cam chain up through the cylinder and hand outside the top. Take care not to bind or damage the piston rings while sliding the piston through the cylinder.

Place the bottom chain guide into the notches in the top of the cylinder head as in the picture here. The bottom of the guide goes into the slot in the case .



Place the cylinder head on top of the engine. Using a new head gasket. Place the head with the cam chain guide inside the head and pull the cam chain through the cam side opening. Secure the chain so that it will not fall down into the engine, keeping tension on the chain to prevent it from coming off the gear on the crankshaft below.



Here something is used to help hold tension on the cam chain while the cylinder head is mounted. Torque the main head nuts down to 26 ft. lbs.

You can now install the cam if removed. Making sure the retaining plate is installed correctly with the rocker pins. Flat side facing inwards as in the picture



Install the cam gear with the cam chain so that it is aligned with the marks on the cylinder head. Making sure the engine is Top Dead Center.

Making sure the timing marks on the rotor are lined up showing 'T' through the timing port.

**CLYINDER
MARK**

TIMING MARKS

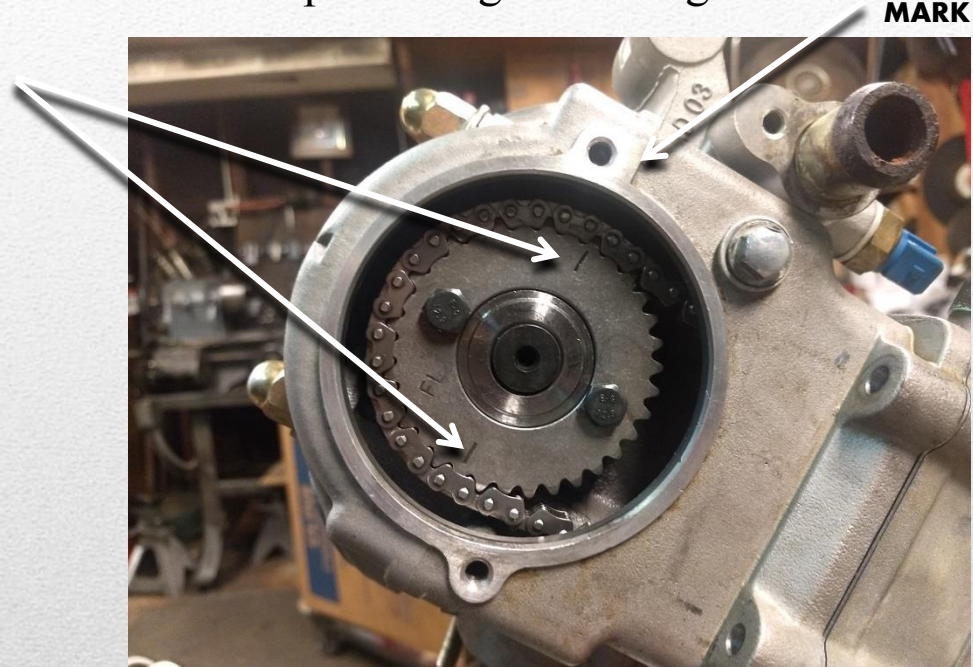

T timing mark showing through the viewing port on the stator cover.

To install the cam chain tensioner, remove the screw in the center, then using a small screwdriver, turn the tensioner so that it retracts back into the tensioner. While securing the tensioner back, install the tensioner into the cylinder with a new gasket. Install the 2 bolts and tighten down to 9 ft. lbs. Re-install the screw to the outside of the tensioner.

Rotate the engine to ensure timing marks are aligned and that there is no valve to piston contact. Once you are sure, the cam cover can be installed as in the picture below.

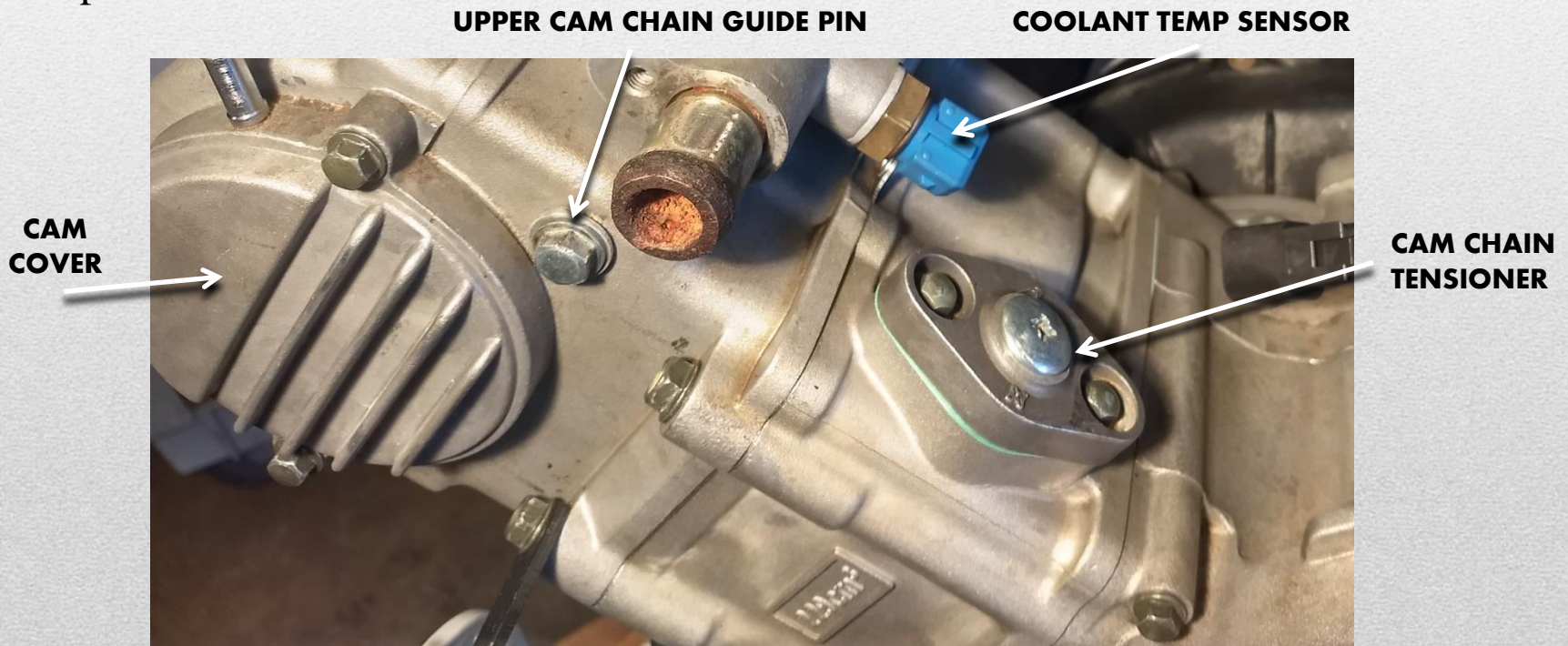

Final assembly should be in the order removed.

- Perform valve adjustment
- Install clutch case
- Install clutches and CVT belt
- Install clutch outer cover
- Install intake manifold if removed.
- Install new oil filter
- Make sure drain plug is tight
- Secure water hose to cylinder head.
- Install starter if removed
- Install new exhaust gasket
- Install new spark plug
- Fill with correct oil once engine is back in chassis and to correct level
- Install countershaft sprocket with special socket
- You are now ready to re install the engine back into the chassis in the reverse order.

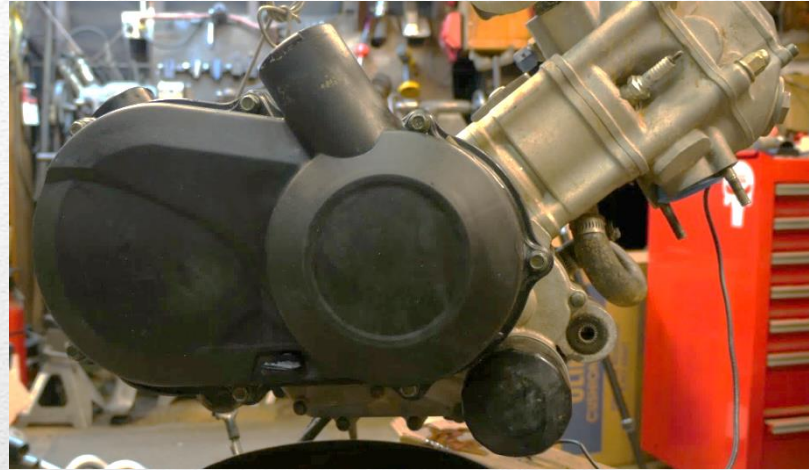

- We hope you have found this information useful for your engine rebuild on the HiSUN line of 250cc engines. Thank you