

WARRIORS OFF ROAD

INSTALLATION INSTRUCTIONS FOR 2" LIFT KIT ON HISUN 250

Always secure the UTV in a safe manor, as removing the wheels might be needed. Additional instructions can be found on our website in the download section

www.warriorsoffroad.com

Rear:

- Start by jacking up the frame towards the rear, do not support the rear axle or swing arm as you will need it free to install the rear portion of the lift kit.
- With the rear wheels supported off the ground, remove them for easy access.
- Remove the lower shock bolts and axle bearing housing bolts.
- Install the rear lift plates so that they look like the ones in the picture below.
- Use the long spacer to replace the area where the shock used to be
- Use the two smaller spacers on either side of the shock in the upper location as in the pic below



Front:

- Start by jacking up the frame so that the front wheels are free and the A arms are free to move as well.
- Remove the front wheels for easier access
- Remove the front shocks
- Install the front upper lift plates so that they look like the picture below
- The front plate on the outside of the OEM shock mount and the rear plate inside of the shock mount.
- Use the supplied spacer to insert where the shock used to be
- Mount the shock back in
- Tighten all bolts down to 35 ft. lbs. front and rear.

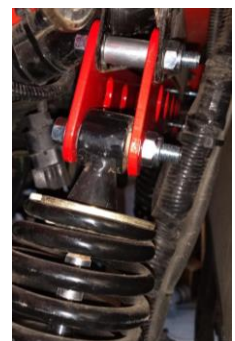
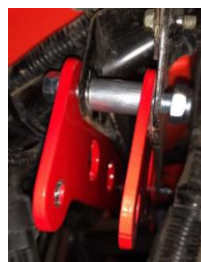

NOTE:

- You will need to re adjust the chain when the rear lift kit is installed.
- You will need to perform a front wheel alignment when the lift kit is installed.

Front wheel alignment

On our website and on YouTube we have a video showing how to perform the front wheel alignment. Please watch this video.

YouTube: Hisun 250 wheel alignment

You will need assistance with measuring the front wheels. Measure the center of the front tire from right to left, and then on the rear of the front tires right to left. The front measurements should be between 1/8" to 1/4" closer for proper toe in. Keep in mind to use your assistant to make sure the steering wheel stays centered during your adjustments.

- Perform wheel alignment with UTV on ground with wheels on.
- Keep the steering wheel centered
- Loosen the jam nuts on the tie rods both outside and inside.
- Turn each tie rod one turn at a time, repeating the same turn for each side. Never adjust just one side as it will cause incorrect wheel alignment and steering problems will result.
- Remember to bounce the front suspension to settle the front end between each adjustment.

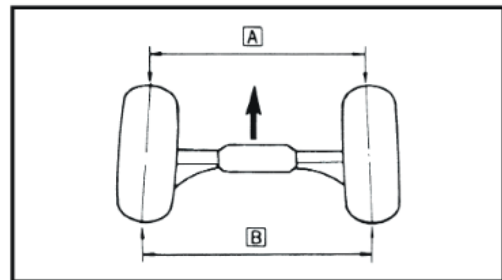

Measure the front wheels from center to center in the front and rear of the front tires. The front should be between 1/8" to 1/4" toe in.

- Once the correct wheel alignment is reached, tighten each jam nut making sure not to turn the tie rod to keep the correct measurements.
- Jam nuts use a 14mm wrench. Using a crows foot wrench on the inside makes it easier to access the jam nut closest to the steering box.

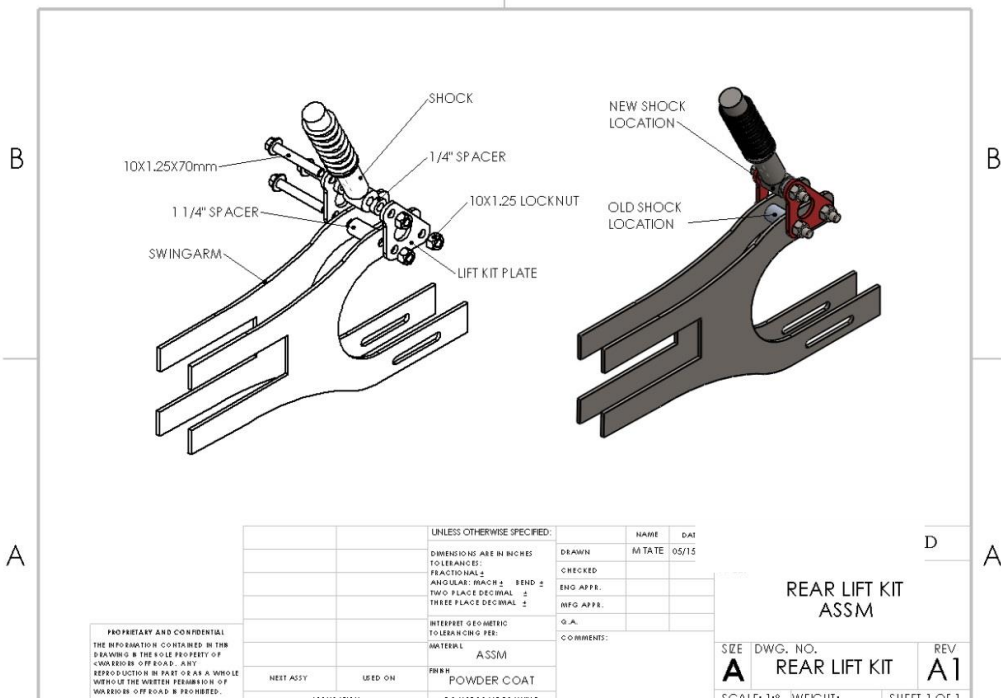
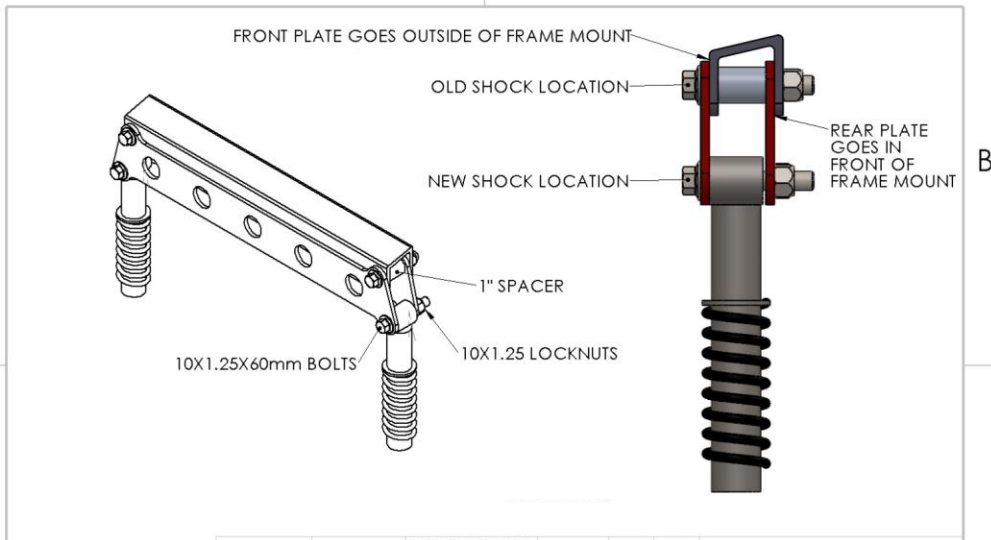

UNLESS OTHERWISE SPECIFIED:		NAME	DATE
	DIMENSIONS ARE IN INCHES	DRAWN	M.TATE 05/15
	TOLERANCES:	CHECKED	
	FRACTIONAL ±	ENG APPR.	
	ANGULAR: BEND ±	MFG APPR.	
	TWO PLACE DECIMAL ±	G.A.	
	THREE PLACE DECIMAL ±	COMMENTS:	
	INTERFERE GEOMETRIC TOLERANCES PER:		
	MATERIAL		
	ASSM		
	FINISH		
	POWDER COAT		
NEXT ASSY	USED ON		

REAR LIFT KIT ASSM

SIZE	DWG. NO.	REV
A	REAR LIFT KIT	A1
SCALE: 1:1		SHEET 1 OF 1

PROPRIETARY AND CONFIDENTIAL
 THE INFORMATION CONTAINED IN THIS
 DRAWING IS THE SOLE PROPERTY OF
 WARRIORS OFF ROAD, INC.
 REPRODUCTION IN PART OR AS A WHOLE
 WITHOUT THE WRITTEN PERMISSION OF
 WARRIORS OFF ROAD IS PROHIBITED.