

WMQHA

Working Cowhorse

Show Date: 07-23-2022

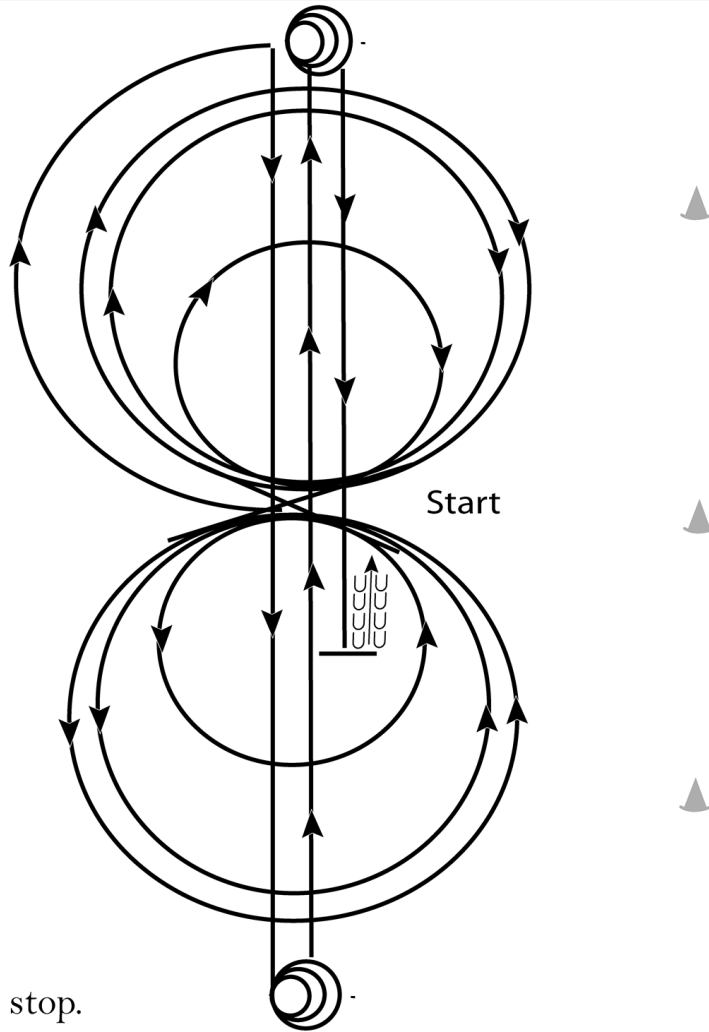

Pattern 9

Trot to center of arena, stop.

Start pattern facing towards judge.

1. Beginning on the right lead, complete 3 circles to the right; the first circle small and slow followed by two large fast circles. Change leads at the center of the arena.
2. Complete 3 circles to the left, the first circle small and slow followed by two large fast circles. Change leads at the center of the arena.
3. Continue around end of arena without breaking gait or changing leads, run down center of arena past end marker, and execute a square sliding stop.
4. Complete 3 1/2 spins to the left.
5. Run down center of arena past end marker and execute a square sliding stop.
6. Complete 3 1/2 spins to the right.
7. Run down center of arena past center marker and execute a square sliding stop.
8. Back at least 10 feet. Hesitate to complete pattern.

[NRCHAWC/9]

Pattern Provided by:

Show Management

VRH Ranch Reining Pattern I

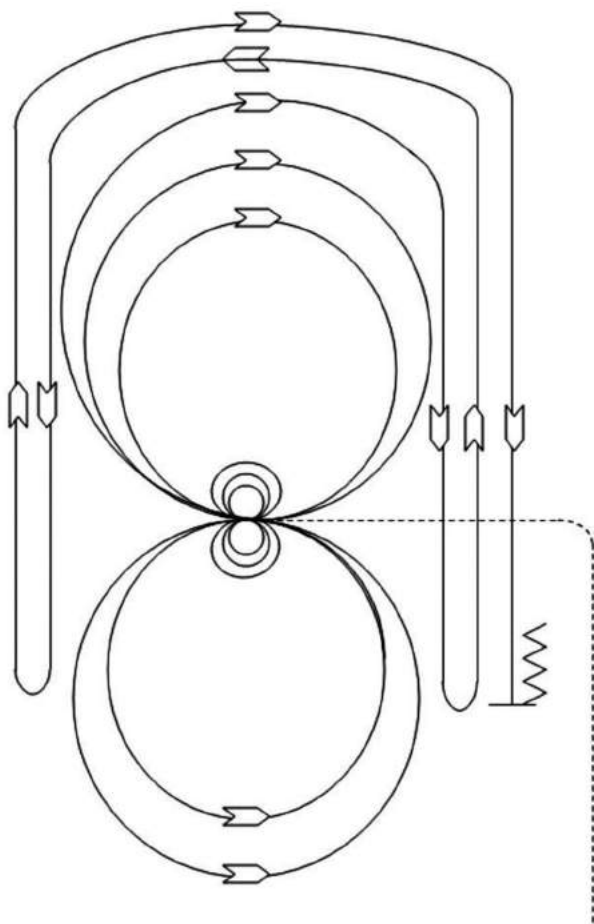

Mandatory Markers:

The judge shall indicate with markers on arena fence the center of the pattern.

Ride pattern as follows:

1. Trot to center of arena and stop.
2. Complete three spins in each direction
3. Begin on right lead and lope two large fast circles to the right, change leads.
4. Lope two large fast circles to the left, change leads.
5. Begin a large circle to the right but do not close this circle. Run down the right side of the arena past the center marker and do a left roll back at least 20 feet from the wall or fence, no hesitation.
6. Continue back around the previous circle but do not close this circle. Run down the left side of the arena past the center marker and do a right roll back at least 20 feet from the wall or fence, no hesitation.
7. Continue back around previous circle but do not close this circle. Run down the right side of the arena past the center marker and do a sliding stop at least 20 feet from the wall or fence. Back up at least 10 feet. Hesitate to show completion of pattern.

WMQHA

Showmanship (All)

Show Date: 07-23-2022

w w w . H o r s e S h o w P a t t e r n s . c o m

w w w . H o r s e S h o w P a t t e r n s . c o m

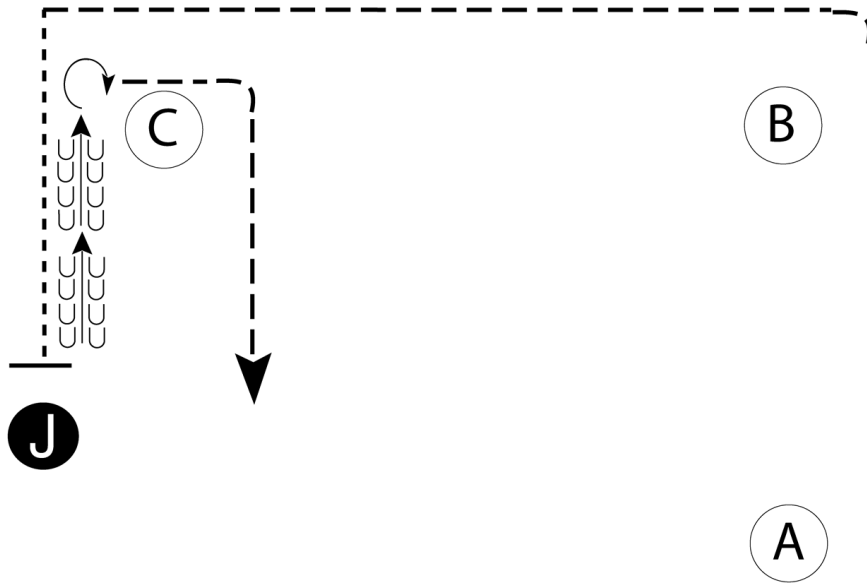

Be ready at A.

1. Trot from A, around B and past C.
2. Break to a walk when past C.
3. Walk to the judge, stop and set up for inspection.
4. When dismissed, back past C.
5. Perform a 270 degree turn and trot around C to the exit.

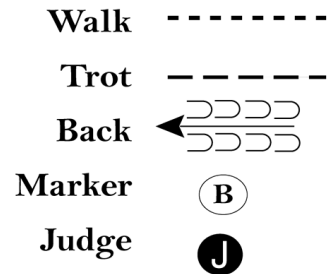

Follow the instructions of your ring steward.

[S/2-50]

Pattern Provided by:
Show Management

WMQHA

Western Horsemanship (All W/T)

Show Date: 07-23-2022

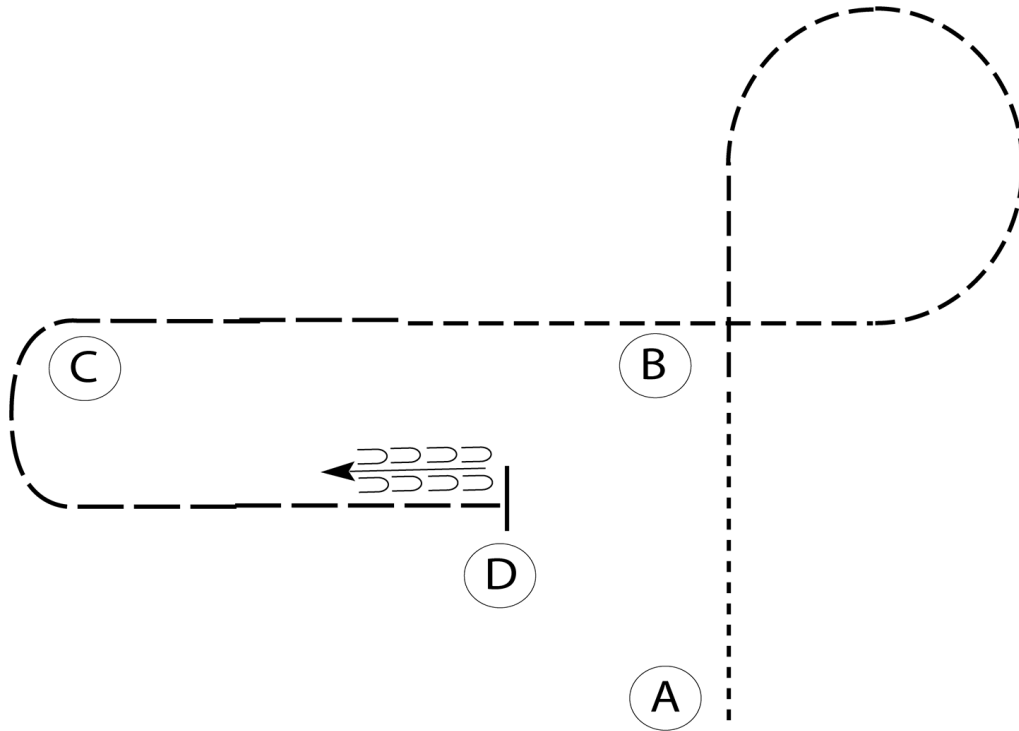

Be ready at A.

1. Walk from A to B.
2. Jog a circle to the right.
3. Halfway between B and C, extend the jog.
4. Extend the jog to D.
5. Stop at D and back approximately one horse length.

Follow the instructions of your ring steward.

Walk	-----
Jog	-----
Extended Jog	-----
Lope	-----
Leg Yield	
Lead Change	— / —
Back	← ← ← ← ←
Marker	(B)
Sidepass	← ← ← ← ←

[WH/WT-70]

Pattern Provided by:
Show Management

WMQHA

Western Horsemanship (All W/T/L)

Show Date: 07-23-2022

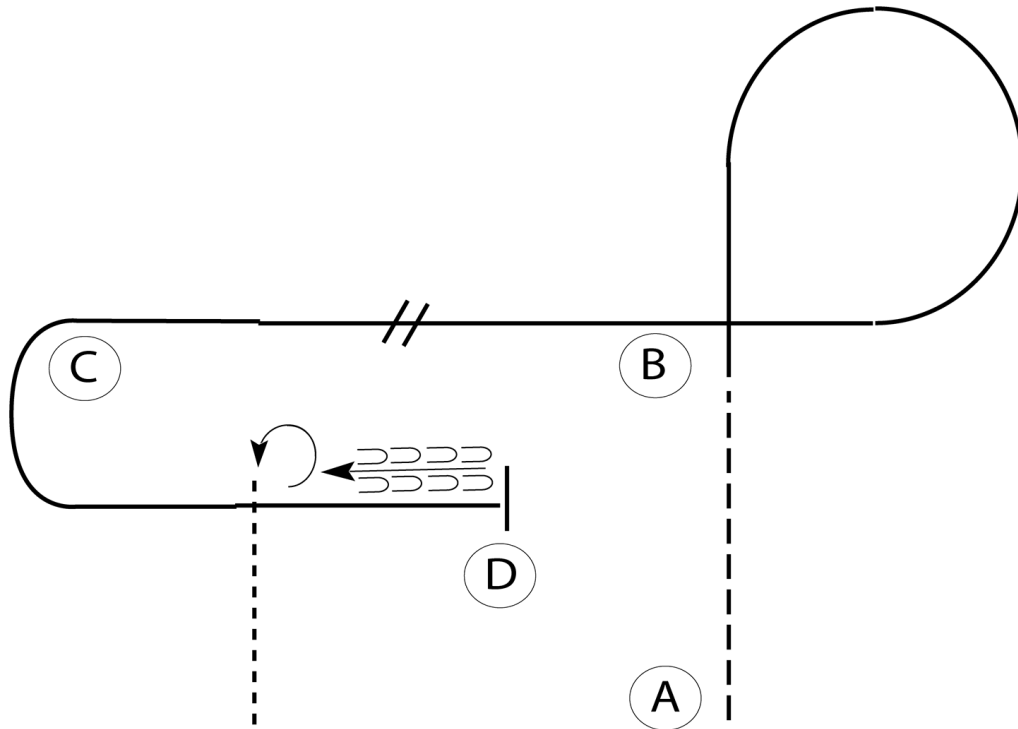

Be ready at A.

1. Jog from A to B.
2. Lope a circle to the right.
3. Halfway between B and C, perform a lead change.
4. Lope on the left lead to D.
5. Stop at D and back approximately one horse length.
6. Spin $\frac{3}{4}$ turn to the left and walk off.

Follow the instructions of your ring steward.

Walk	-----
Jog	- - - - -
Extended Jog	- - - - -
Lope	—————
Leg Yield	
Lead Change	— / —
Back	← ⊃ ⊃ ⊃
Marker	(B)
Sidepass	← — — — — →

[WH/2-70]

Pattern Provided by:
Show Management

WMQHA

Western Riding (All Green)

Show Date: 07-23-2022

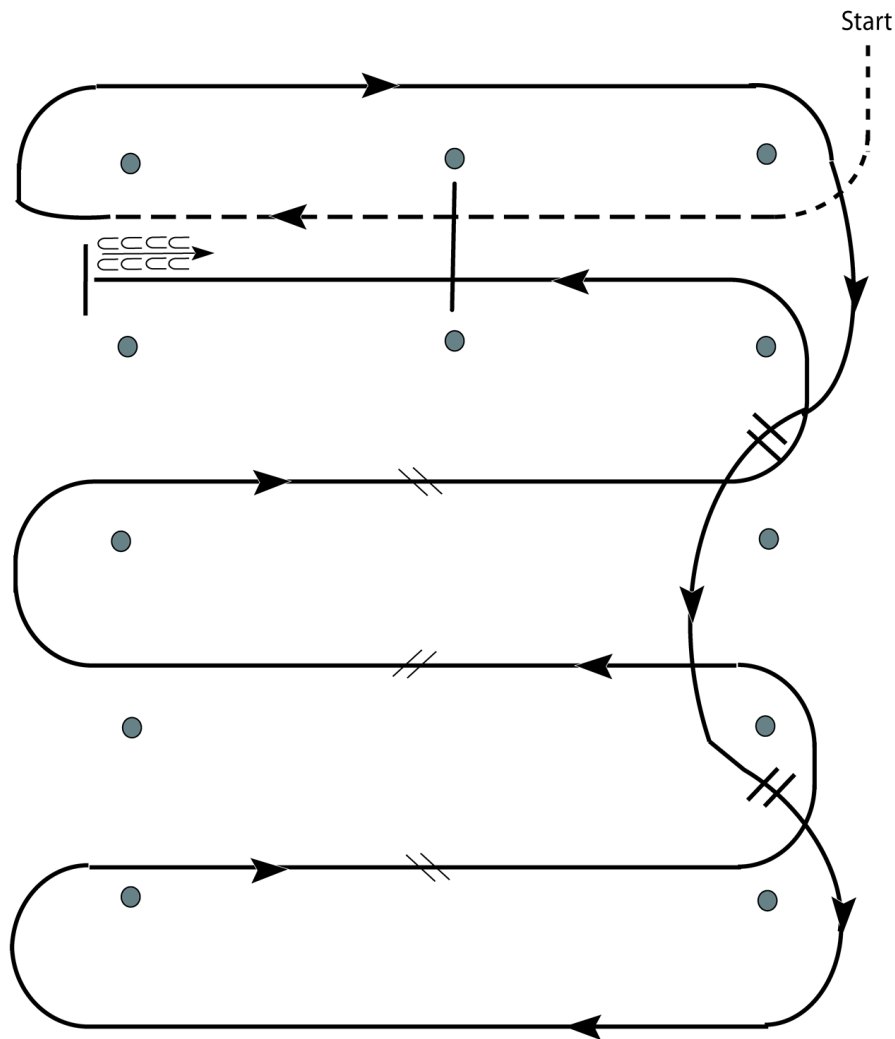

1. Walk, transition to jog, jog over log.
2. Transition to right lead and lope around end.
3. First line change.
4. Second line change. Lope around end of arena.
5. First crossing change.
6. Second crossing change.
7. Third crossing change.
8. Lope over log.
9. Lope, stop and back.

[WR/GP-4]

Pattern Provided by:
Show Management

WMQHA

Western Riding

Show Date: 07-23-2022

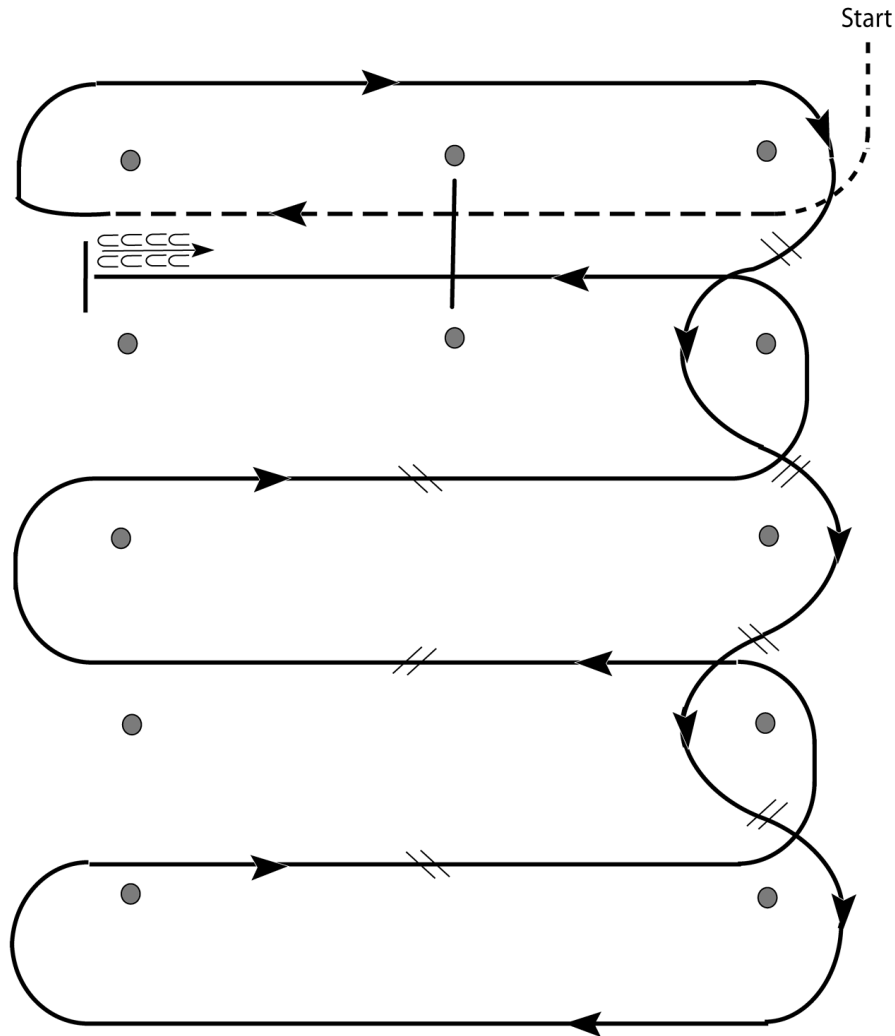

1. Walk, transition to jog, jog over log.
2. Transition to right.
3. First line change.
4. Second line change.
5. Third line change.
6. Fourth line change.
7. First crossing change.
8. Second crossing change.
9. Third crossing change.
10. Lope over log.
11. Lope, stop and back.

[WR/OP-4]

Pattern Provided by:
Show Management

WMQHA

Reining

Show Date: 07-23-2022

REINING PATTERN 7

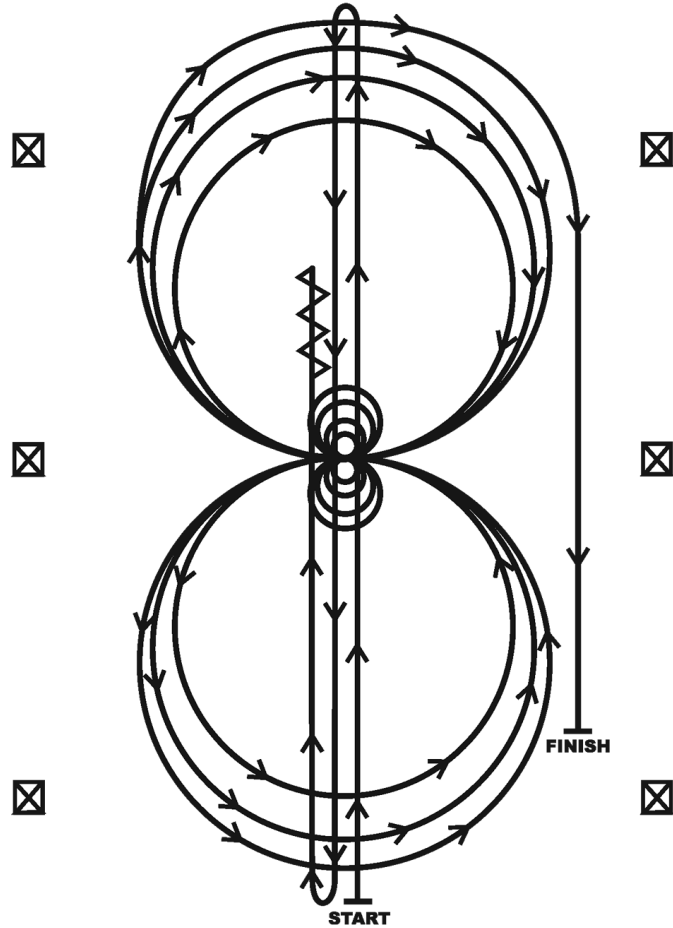

1. Run at speed to the far end of the arena past the end marker and do a left rollback—no hesitation.
2. Run to the opposite end of the arena past the end marker and do a right rollback—no hesitation.
3. Run past the center marker and do a sliding stop. Back up to the center of the arena or at least ten feet (three meters). Hesitate.
4. Complete four spins to the right. Hesitate.
5. Complete four and one-quarter spins to the left so that horse is facing left wall or fence. Hesitate.
6. Beginning on the right lead, complete three circles to the right: the first two circles large fast; the third circle small and slow. Change leads at the center of the arena.
7. Complete three circles to the left: the first two circles large fast; the third circle small and slow. Change leads at the center of the arena.
8. Begin a large circle to the right but do not close this circle. Run straight down the right side of the arena past the center marker and do a sliding stop at least twenty feet (six meters) from the wall or fence. Hesitate to demonstrate completion of the pattern.

[R/AQHAP-7]

Pattern Provided by:
Show Management

WMQHA

Ranch Riding

Show Date: 07-23-2022

www.HorseShowPatterns.com

www.HorseShowPatterns.com

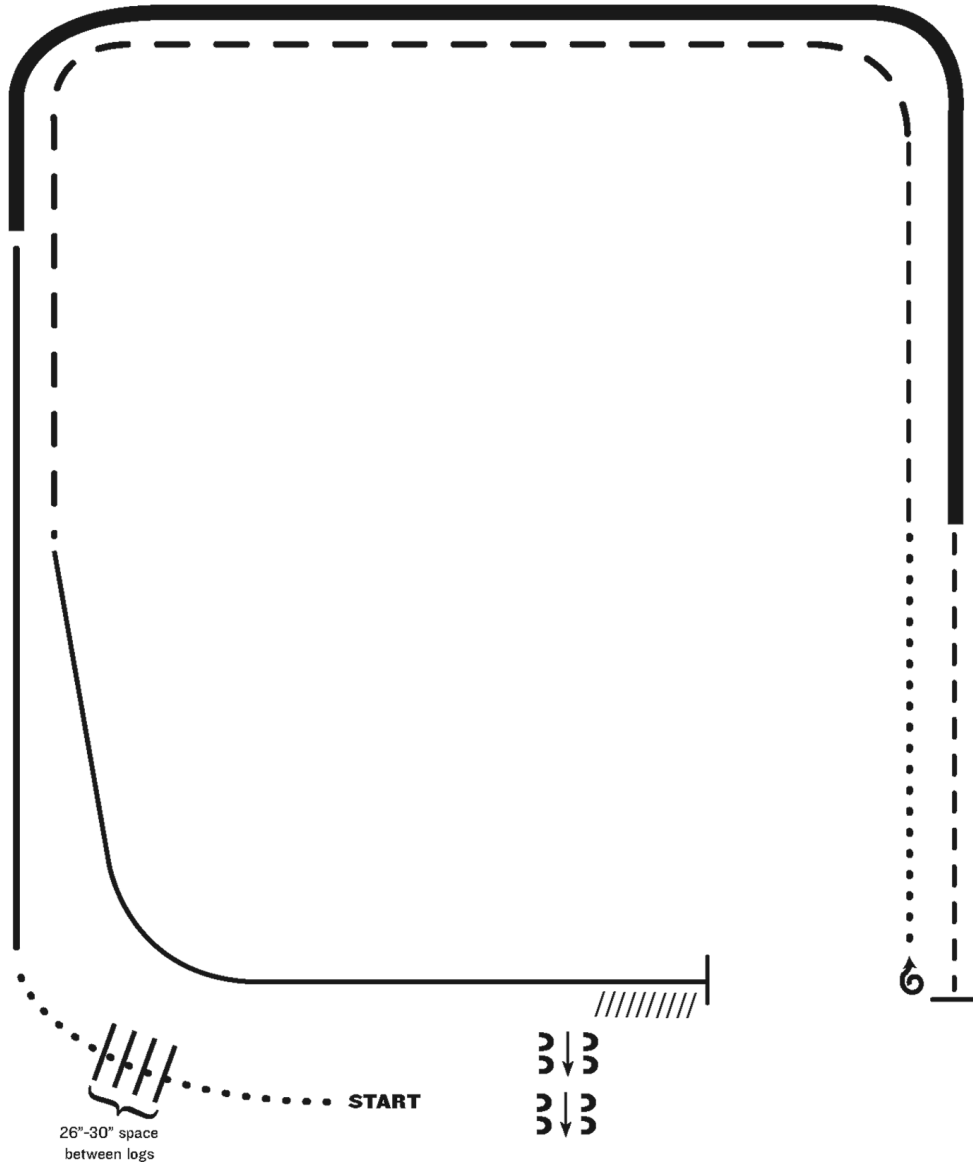

1. Walk
2. Walk over logs
3. Lope right lead
4. Extended lope (right lead)
5. Trot
6. Stop, 1 1/2 turns right
7. Walk
8. Trot
9. Extended trot
10. Lope left lead
11. Stop and Back
12. Side pass right

Note: The drawn description of this pattern is only intended for the general depiction of the pattern. Exhibitors should utilize the arena space to best exhibit their horses.

[RR/AQHA-6]

Pattern Provided by:
Show Management

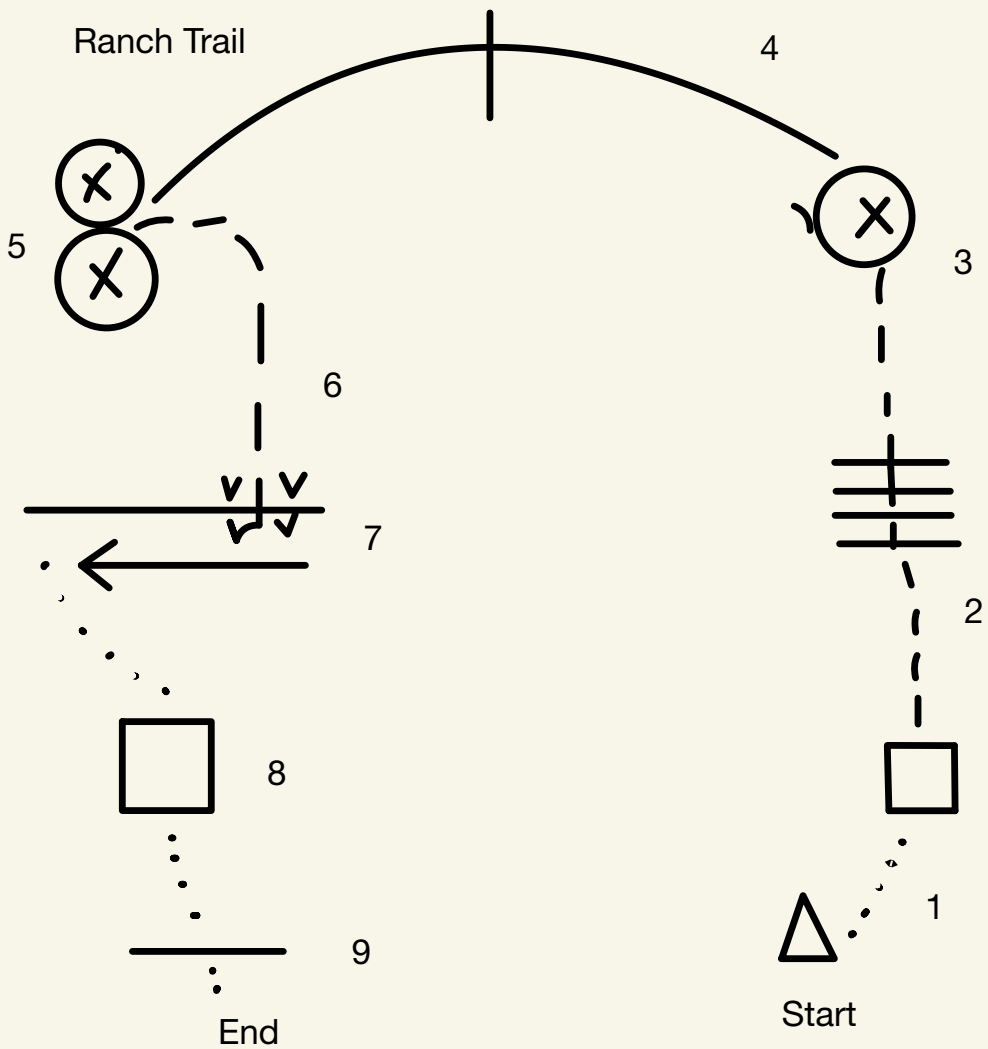

1. Walk to roping dummy. 1 loop leave your rope.
2. Trot. Trot over logs. Trot to Drag.
3. Drag log 1 time around. Youth and VRH Rookie no Drag.
4. Lope Left Lead over jump. Stop. 90 Degree Left.
5. Back Figure 8 around rocks.
6. Extended Trot. Stop over log.
7. Sidepass Right.
8. Walk. Walk over bridge. Walk to gate.
9. Work Gate. Pattern Complete.

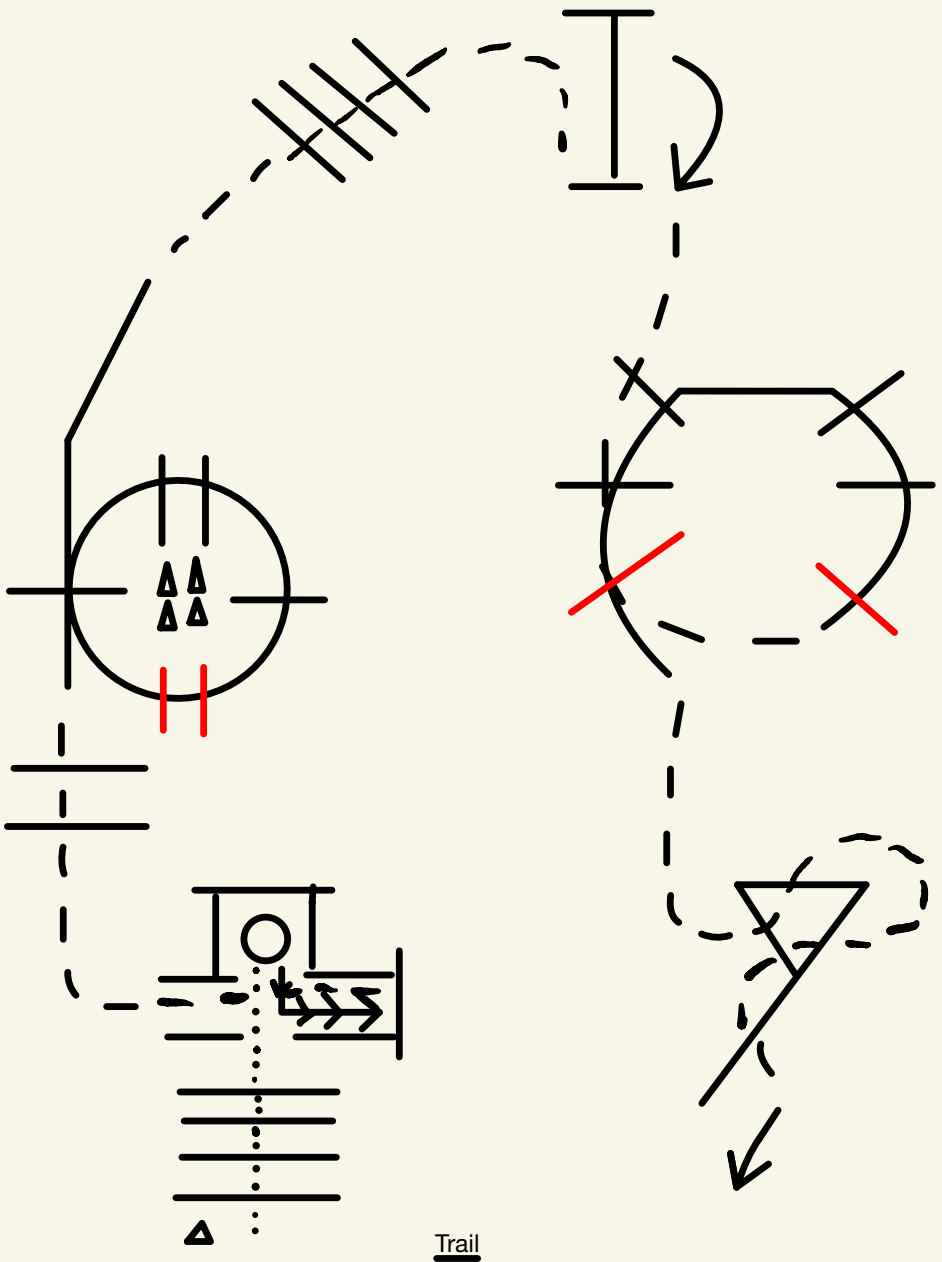

(W/T Jog where loping is shown)

Remove Red Polls for All Rookie, W/T, L1 and In hand classes

1. Walk over logs and into box.
2. 360 ether direction
3. Back L
4. Jog out and over polls
5. Right Lead Lope overs (W/T classes jog)
6. Jog overs
7. Gate. Left Hand Push.
8. Turn to the right and jog over logs.
9. Left Lead Lope overs (W/T classes jog)
10. Jog over as shown.

WMQHA

Hunt Seat Equitation (All W/T)

Show Date: 07-23-2022

w w w . H o r s e S h o w P a t t e r n s . c o m

w w w . H o r s e S h o w P a t t e r n s . c o m

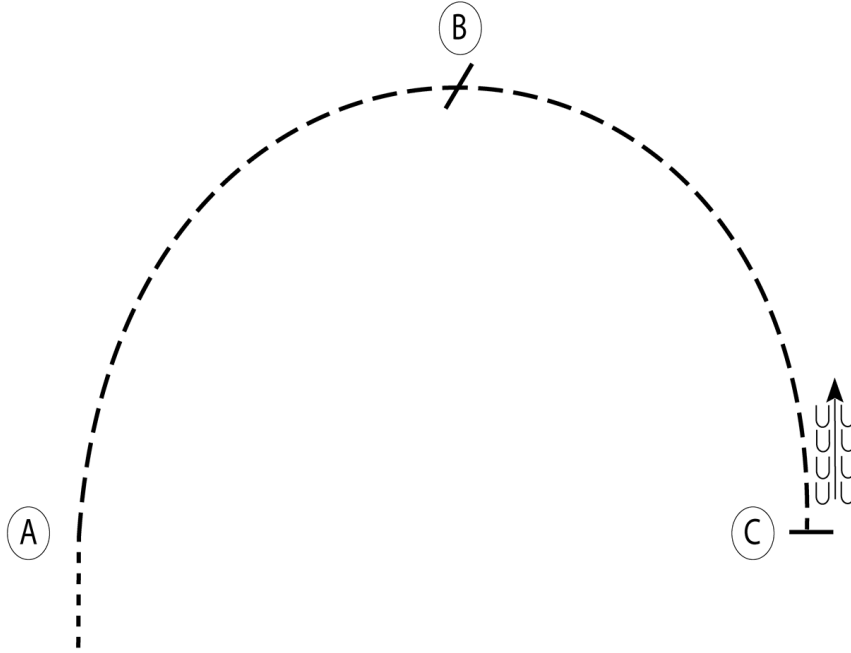

Be ready before A.

1. Walk to A.
2. Trot on the left diagonal from A towards B.
3. At B, change diagonals and continue to C.
4. Stop at C and back approximately one horse length.

Follow the instructions of your ring steward.

Walk	-----
Trot	- - - - -
Extended Trot	-----
Canter	-----
Leg Yield	
Lead Change	↘
Back	←←←←←
Marker	(B)
Sidepass	←-----→
Hand Gallop	-----

[HSE/WT-36]

Pattern Provided by:
Show Management

WMQHA

Hunt Seat Equitation (All W/T/C)

Show Date: 07-23-2022

w w w . H o r s e S h o w P a t t e r n s . c o m

w w w . H o r s e S h o w P a t t e r n s . c o m

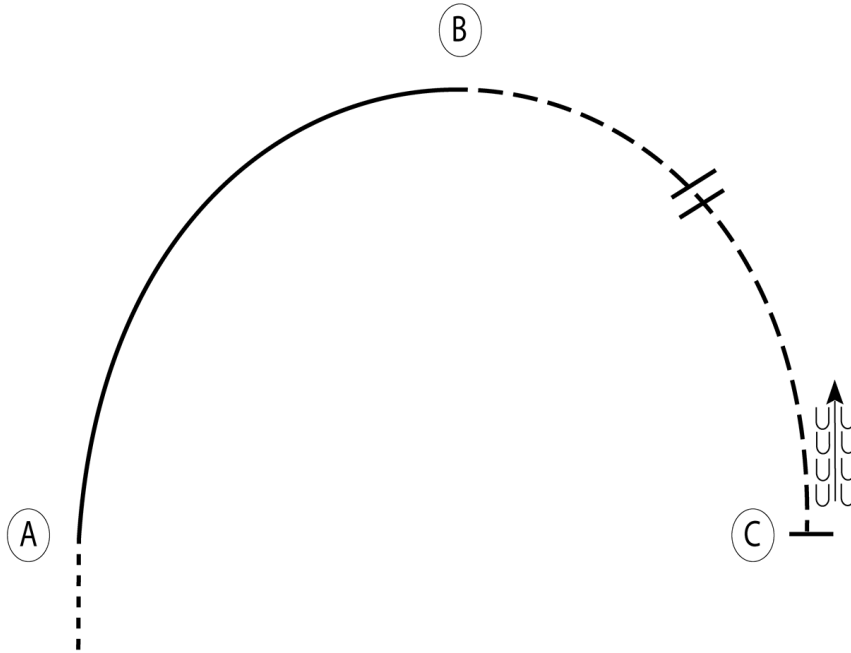

Be ready before A.

1. Walk to A.
2. Canter on the right lead from A towards B.
3. Break to a posting trot at B.
4. At B, posting trot on the left diagonal towards C.
5. When halfway to C, change diagonals and continue to C.
6. At C stop and back approximately one horse length.

Follow the instructions of your ring steward.

Walk	-----
Trot	- - - - -
Extended Trot	-----
Canter	-----
Leg Yield	
Lead Change	↘
Back	←←←←←
Marker	⊙
Sidepass	←---→
Hand Gallop	-----

[HSE/1-36]

Pattern Provided by:
Show Management