

*Daytona*

BY **CSC**  
*TRIKES*

## **Trike Conversion Kit**

**1999 - 2008**

**FLHT Series Harley-Davidson**

# **Installation Instructions**

**REVISED 7 - 2017**

**California Sidecar Parts & Technical Support  
434.263.8866**



## **Table of contents:**

<b>1. Warnings and considerations</b>	<b>4</b>
<b>2. General information</b>	<b>5</b>
<b>3. Maintenance Schedule</b>	<b>6</b>
<b>4. Disassembly of motorcycle</b>	<b>7</b>
<b>5. Performance Gear Set</b>	<b>17</b>
<b>6. 6 Speed Front Drive Belt Installation</b>	<b>18</b>
<b>7. 5 Speed Front Drive Belt Installation</b>	<b>19</b>
<b>8. Modification of Frame</b>	<b>24</b>
<b>9. Rear Suspension Unit Installation</b>	<b>25</b>
<b>10. Frame Mount Installation</b>	<b>28</b>
<b>11. Brake line Installation</b>	<b>30</b>
<b>12. Bleeding the brake system</b>	<b>32</b>
<b>13. ABS Brake Equipped Bikes</b>	<b>33</b>
<b>14. Link to CSC Belt Tensioning video</b>	<b>34</b>
<b>15. Setting up the Sonic Tension Meter</b>	<b>34</b>
<b>16. Using the Sonic Tension Meter</b>	<b>34</b>
<b>17. Tensioning the Front Drive Belt</b>	<b>35</b>
<b>18. Gravel Pan</b>	<b>36</b>
<b>19. Reinstall Exhaust Head Pipes</b>	<b>38</b>
<b>20. Exhaust Mount Installation</b>	<b>39</b>
<b>21. Exhaust Installation</b>	<b>40</b>
<b>22. Tensioning the Rear Drive Belt</b>	<b>42</b>
<b>23. Service limits on Drive Belts</b>	<b>43</b>
<b>24. Suspension Setup</b>	<b>44</b>
<b>25. Trike body installation</b>	<b>46</b>
<b>26. Tour Pak Installation</b>	<b>46</b>
<b>27. Trike Body Alignment</b>	<b>48</b>
<b>28. Securing the Trike Body</b>	<b>49</b>
<b>29. Reassembly of the motorcycle</b>	<b>50</b>
<b>30. Final reassembly of the motorcycle</b>	<b>50</b>

## **Warnings and considerations:**

- 1. Disclaimer** - These instructions assume a level of understanding of motorcycle repair and maintenance beyond that of a “beginner” and/or “novice” and California Sidecar cannot be liable for an installer’s failure to understand or follow these instructions as written. Likewise, California Sidecar cannot be responsible if any of the steps are omitted or shortcuts are taken, or parts other than those supplied by California Sidecar, are used in installing this trike kit.
- 2. “WARNINGS”** are all printed in bold type and capitalized. They mean to use extreme care in a given step so as not to damage the part, motorcycle, and/or yourself.
- 3. Always** wear safety glasses when using hand and/or power tools.
- 4. When** working in and around the fuel system, **always** work in a well-ventilated area, free from sparks and open flames.
- 5. All** directional references to the “right side” and the “left side” are as you were seated on the motorcycle.
- 6. All** directional references to “forward” mean to the front of the motorcycle while “back” means the rear of the motorcycle unless otherwise stated.
- 7. Please** consult the appropriate Service Manual for your motorcycle if further detail is necessary.

## **Recommended Lubricants and Sealants:**

- 1. Molybdenum Disulfide grease for splines (Mobil Grease Moly 52 or equivalent)**
- 2. Multipurpose grease for Zerk fittings.**
- 3. Thread locking compound (Loctite 242 minimum).**
- 4. High temperature Silicone sealant.**

## **Torque values of fasteners:**

- 1. Rear Fork Pivot Shaft Nut 40 – 45 FT. - LBS.**
- 2. 7/16 – 14 x 1 1/2 HHCS 38 – 42 FT. - LBS.**
- 3. 3/8–16 x 1 BHCS for the upper mount 12 FT. - LBS.**
- 4. 3/8–16 nyloc nut for rear suspension studs 12 FT. - LBS.**
- 5. 1/2 - 13 x 2 HHCS 75 FT. - LBS.**
- 6. 7/16 – 20 x 1 1/2 HHCS 38 – 42 FT. - LBS.**

## Maintenance Schedule: DAYTONA

Frequency (miles)	Daily	4k	8k	12k	16k	20k	24k
Item	/	/	/	/	/	/	/
Belts	I	I	I	I	I	T	I
Brake Pads and Rotors [1]		I	I	I	I	I	I
Half Shaft Boots		L	L	L	L	L	L
Wheel Bearings [2]		I	I	I	I	I	I
Wheels and Tires		I	I	I	I	I	I
All Lighting	I						
Tire Pressure [3]	I						
Brake fluid		I	I	R	I	I	R

**I: Inspect: clean, lubricate, and/or replace as necessary.**

**R: Replace**

**L: Lubricate with Silicone Spray**

**T: Tension**

**NOTE:** [1] Minimum pad thickness is 0.04 inches (1.02mm)

[2] Wheel bearing torque 200 FT.-LBS.

[3] Rear tire pressure 15" & 16" wheels 28 PSI  
17" wheels 25 PSI

**At higher odometer readings, repeat at frequency intervals established here.**

**NOTE:**

**This Schedule is in addition to the Harley Davidson Maintenance Schedule**

**NOTICE:**

**The remote door opener installed on this unit has a very small electrical draw on your motorcycle battery. If your trike will be unriden for more than 2 weeks you should remove the 15 amp fuse from the red fuse holder located under your seat or right side cover. Another option is using a battery tender.**

## **Disassembly of motorcycle:**

- 1. Place the motorcycle on the lift.**
- 2. Place a suitable Jack under the Frame of the Motorcycle and tie down securely.**
- 3. Remove Drain Plug from Primary Cover Assembly.**



- 4. Remove Seat screw and Seat.**
- 5. Disconnect negative Battery Terminal.**
- 6. Remove two 1/4 - 20 flanged hex nuts from the Stud Plate.  
Save the Passenger Handrail and two nuts.**
- 7. Remove the Saddle Bags.**
- 8. Remove the Right and Left Side Covers.**
- 9. Remove Passenger Footboards.**





- 10. Remove Inner Tour Pak Molded Liner.**
- 11. Disconnect the Tour Pak wiring.**
- 12. Remove five 1/4 - 20 HHCS, 1/4 - 20 nyloc nuts, and Aluminum Spacers.**
- 13. Remove Tour Pak from Top Support Tube.**
- 14. Remove bottom support tube with License plate mount.**
- 15. Loosen Muffler Clamps and remove 2 HHCS per Muffler.  
Remove and discard both Mufflers. Save Muffler Clamps.**
- 16. Remove Left and Right Saddle Bag Guards.**
- 17. Remove two Chrome Frame Covers.**



18. Remove the Air Line Junction from the Rear Fender.
19. Disconnect the Rear Lamp Wiring Harness.
20. Remove four fasteners from the Rear Air Shocks.



**NOTE: if ABS equipped refer to separate instructions.**

21. Drain all Brake Fluid from the Rear Brake System.
22. Cut and remove Cable ties and un-clamp Wire Harness Loops from the Rear Brake Line along its length, including Clamps on Swing Arm.
23. Remove the 10 - 24 flanged HHCS and Rear Brake Hose Clamp from the Right Rear Fork Bracket.
24. Remove  $\frac{1}{4}$  - 20 SHCS from Rear Stop Lamp Switch Bracket.
25. Remove and discard Banjo Bolt and Crush Washers on Rear Brake Caliper.

26. Remove the Spring Clip and nut from the Rear Axle.
27. Remove Rear Axle and Rear Wheel Spacers.
28. Push Rear Wheel Assembly forward and slip Rear Belt off of the Rear Sprocket.
29. Remove Rear Brake Caliper.
30. Slide Rear Wheel Assembly rearward.
31. Remove one 5/16 - 18 Torx HCS from the front of the inside of the Rear Fender.

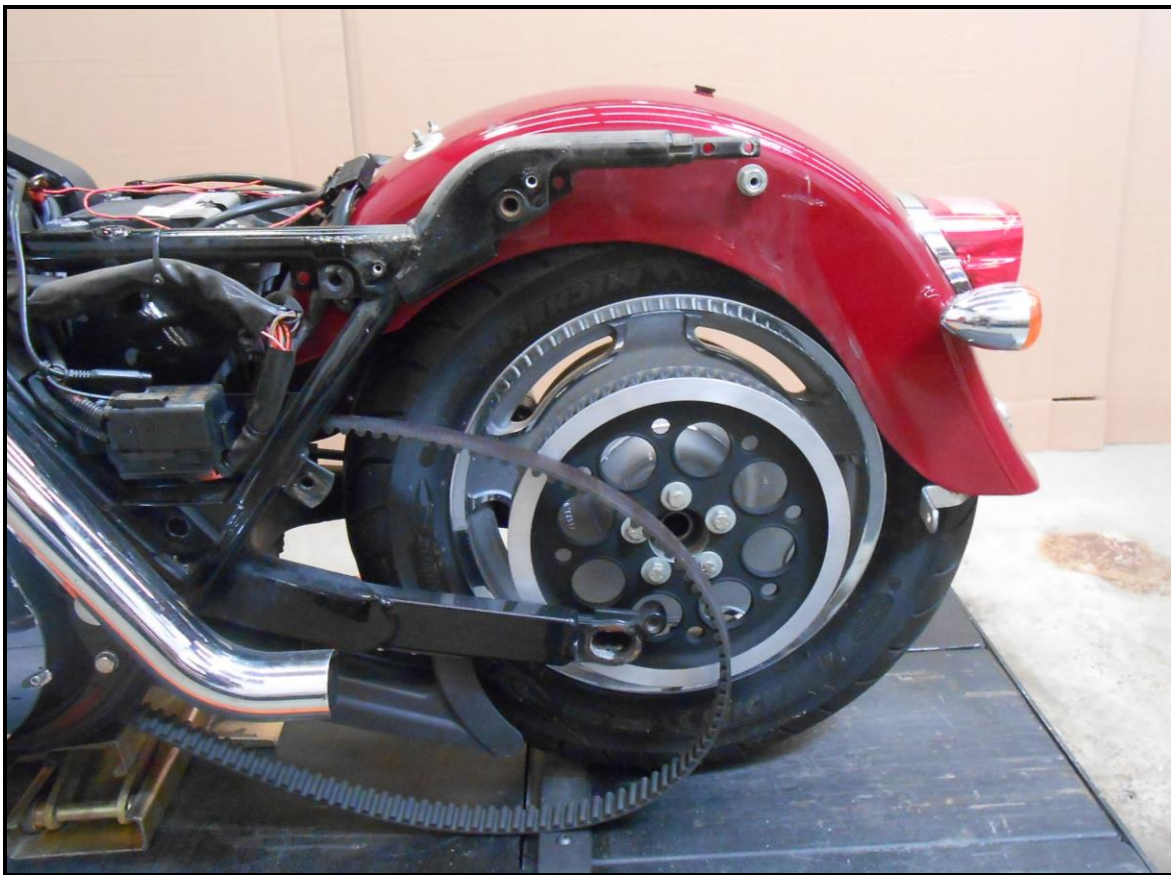

- 32. Slide Rear Wheel Assembly forward. Remove two 5/16 – 18 Torx HCS. Remove Rear Fender.**
- 33. Remove and save the two Retaining Washers from the Stud Plate. Remove and save the Stud Plate.**
- 34. Remove Rear Wheel Assembly.**



- 35. Loosen two 1/2 - 13 SHCS on the Right Drivers Footboard.**
- 36. Remove Heat Shields from Exhaust Pipes.**
- 37. Remove two 5/16 – 18 SHCS from the Starter Motor.**
- 38. Loosen 5/16 – 18 flange nut on the Exhaust Mount Support Bracket.**
- 39. Loosen Exhaust Pipe Clamp and Bracket for the Left Exhaust Pipe. Remove Left Exhaust Pipe.**
- 40. Remove four 5/16 – 24 flanged hex nuts from Cylinder Head Studs one 1/4 - 20 HHCS and 1/4 - 20 hex nut on Exhaust Pipe to Bracket clamp. Remove Front and Rear Exhaust Pipes.**

- 41. Place a suitable Jack under the Oil Pan of the Transmission. Raise Jack to enable easy removal of the Rubber Mounts and Rear Fork Pivot Shaft.**
- 42. Remove four 7/16 – 14 HHCS and washers. Remove Left and Right Rear Fork Bracket.**
- 43. Remove Left Rear Fork Shaft Nut. Remove Cup Washer from Rear Fork Pivot Shaft.**
- 44. Remove Rear Fork Pivot Shaft.**
- 45. Remove and discard the Rear Swing Arm.**
- 46. Remove Rear Fork Pivot Shaft Nut on the right side of the Shaft. Remove the Cup Washer, Rubber Mount and Spacer. Discard Spacer and replace Rubber Mount and Cup Washer apply thread locking agent to the threads. Reinstall the Swing Arm Pivot Shaft Nut. Torque to spec.**



47. Remove one 1/2 - 13 SHCS, two 5/16 - 18 hex head cap screw, and one 5/16 - 18 nut. Remove the Left Driver Footboard.
48. Remove two 5/16 - 18 HHCS and two 5/16 - 18 nuts. Remove The Jiffy Stand.
49. Remove the Inner and Outer Shift Levers.



50. Remove ten  $\frac{1}{4}$  - 20 SHCS. Remove the Primary Cover.
51. Remove and discard Primary Cover Gasket.
52. Clean residual gasket material from both surfaces.
53. Loosen the Top Center Nut on the Primary Chain Adjuster. Lower the Primary Chain Adjuster until it rests flat on the Inner Primary Cover.
54. Remove the Clutch Lifter Retaining Ring from the Clutch Basket. Remove Clutch Lifter Assembly.
55. Using the Primary Drive Locking Tool. Place it into position and loosen the Compensating Sprocket Nut.
56. Using the Primary Drive Locking Tool. Place it into position and loosen the Clutch Hub Main shaft Nut. **WARNING:** This nut is LEFT HAND threaded.
57. Remove the Primary Drive Locking Tool, Compensating Sprocket Nut, and Clutch Hub Main shaft Nut.
58. Remove the Sprocket cover and Sliding Cam from the Crank Shaft Extension.
59. Remove the Clutch Assembly, Primary Chain, Compensating Sprocket, and Crank Shaft Extension in one assembly.
60. Bend tab on the Starter Jack Shaft bolt Locking Plate away from the head of the Jack Shaft Bolt. Holding the Pinion Gear remove the Jack Shaft Bolt, Lock Plate, and Thrust Washer.
61. Remove the Jack Shaft Assembly from the Primary Chain case.
62. Remove two  $\frac{5}{16}$  - 18 HHCS and two  $\frac{5}{16}$  flat washers from the outside of the Primary Chain case.
63. Bend tabs on the five Lock Plates away from the heads of the five  $\frac{5}{16}$  HHCS on the inside of the Primary Chain case.
64. Remove five  $\frac{5}{16}$  - 18 HHCS and five Lock Plates from the inside of the Primary Chain case. Remove the Primary Chain case.

**65. Remove and Discard the O-Ring from the Crankcase lip.**

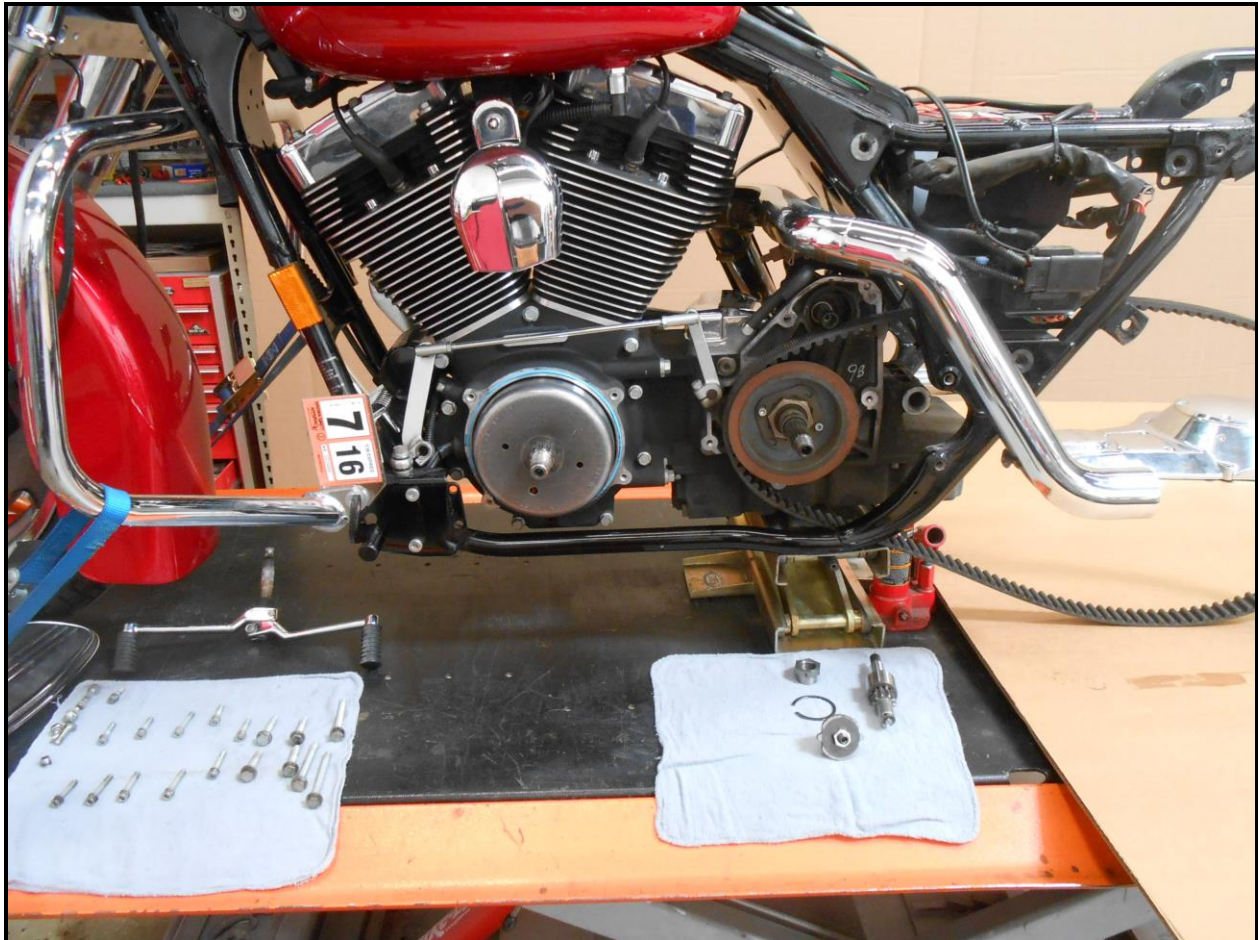

**66. Remove and Discard the Front Final Drive Belt.**



## **ALL MODELS**

**Do not remove drive sprocket unless installing Performance Gearing Set.**

- 1. Remove the OEM sprocket, 5 speeds are Left hand thread and 6 speeds are Right hand threads.**
- 2. Slide New CSC Performance Drive Sprocket onto the splines of the Main Shaft.**
- 3. Lock Final Drive Sprocket with the Final Drive Sprocket Locking Tool.**
- 4. Apply Loctite 262 to the threads of the Final Drive Sprocket Nut.**
- 5. Finger tighten the Final Drive Sprocket nut.**
- 6. Using Special Deep Well Socket and Pilot. Torque the Final Drive Sprocket Nut to**
  - 5 Speed 60 ft-lbs**
  - 6 Speed 35 ft-lbs**
- 7. Scribe a straight line on the Final Drive Sprocket Nut and Final Drive Sprocket.**
- 8. Tighten the Final drive Sprocket Nut an additional 35° to 40°.**
- 9. Place the Final Drive Sprocket Lock Plate over the Final Drive Sprocket Nut and align the holes in the Final Drive Sprocket Lock Plate with the two tapped holes in the Final Drive Sprocket. If these two holes do not line up continue tightening the Final Drive Sprocket Nut to 45° maximum.**
- 10. Reinstall the two 1/4 - 20 SHCS with thread locking agent through the Final Drive Sprocket Lock Plate into the Final Drive Sprocket and torque to 90 - 110 in/lbs.**

## 6 Speed Front Drive Belt Installation:

Install **NEW CSC** Front Drive Belt.

*2007 & 2008 Primary Chaincase torques*  
Inner Primary torque to 25–27 FT-LBS.

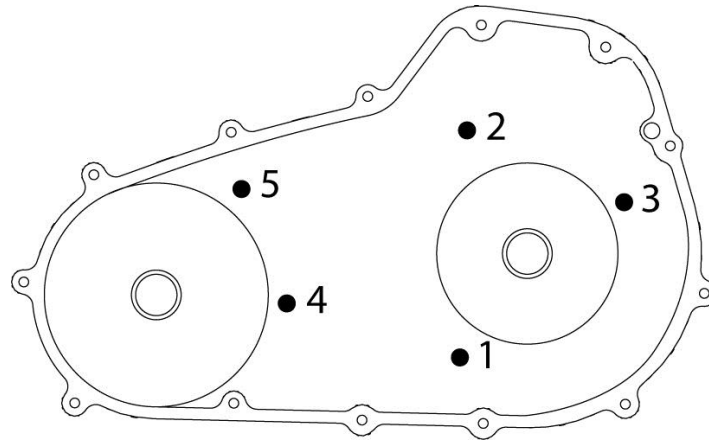

Compensating Bolt torque to 100 FT-LBS then loosen bolt one full turn. Then final torque is 140 FT-LBS.  
Clutch Hub nut torque to 70–80 FT-LBS. LEFT HAND THREAD.

Use 262 Loctite on Compensating Bolt and Clutch Hub nut.  
Do steps 38 - 44 then return.

Outer Primary cover torque to 108–120 IN-LBS.  
Fill with 45 oz of Primary Chaincase Lubricant.  
Clutch Inspection Cover torque to 84-108 IN-LBS.

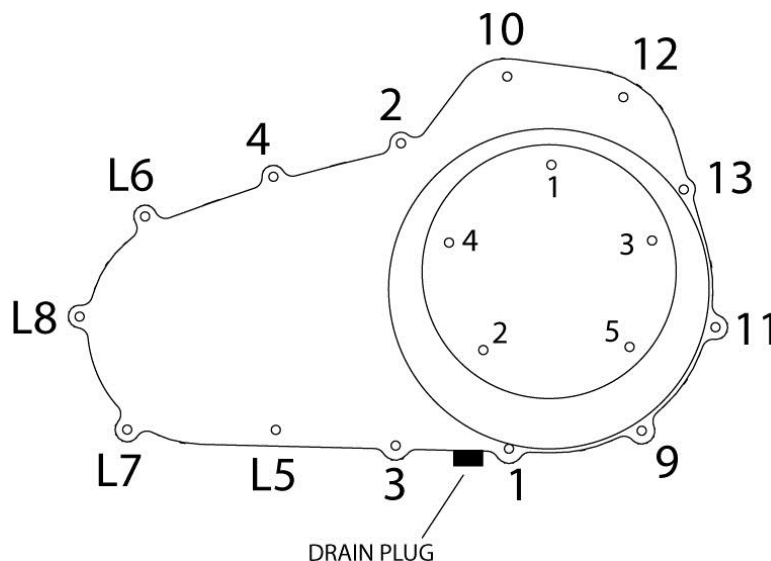

## 5 Speed Front Drive Belt Installation:

1. Install **NEW CSC** Front Drive Belt.
2. Install new Crank Case O-Ring onto the Crank Case.

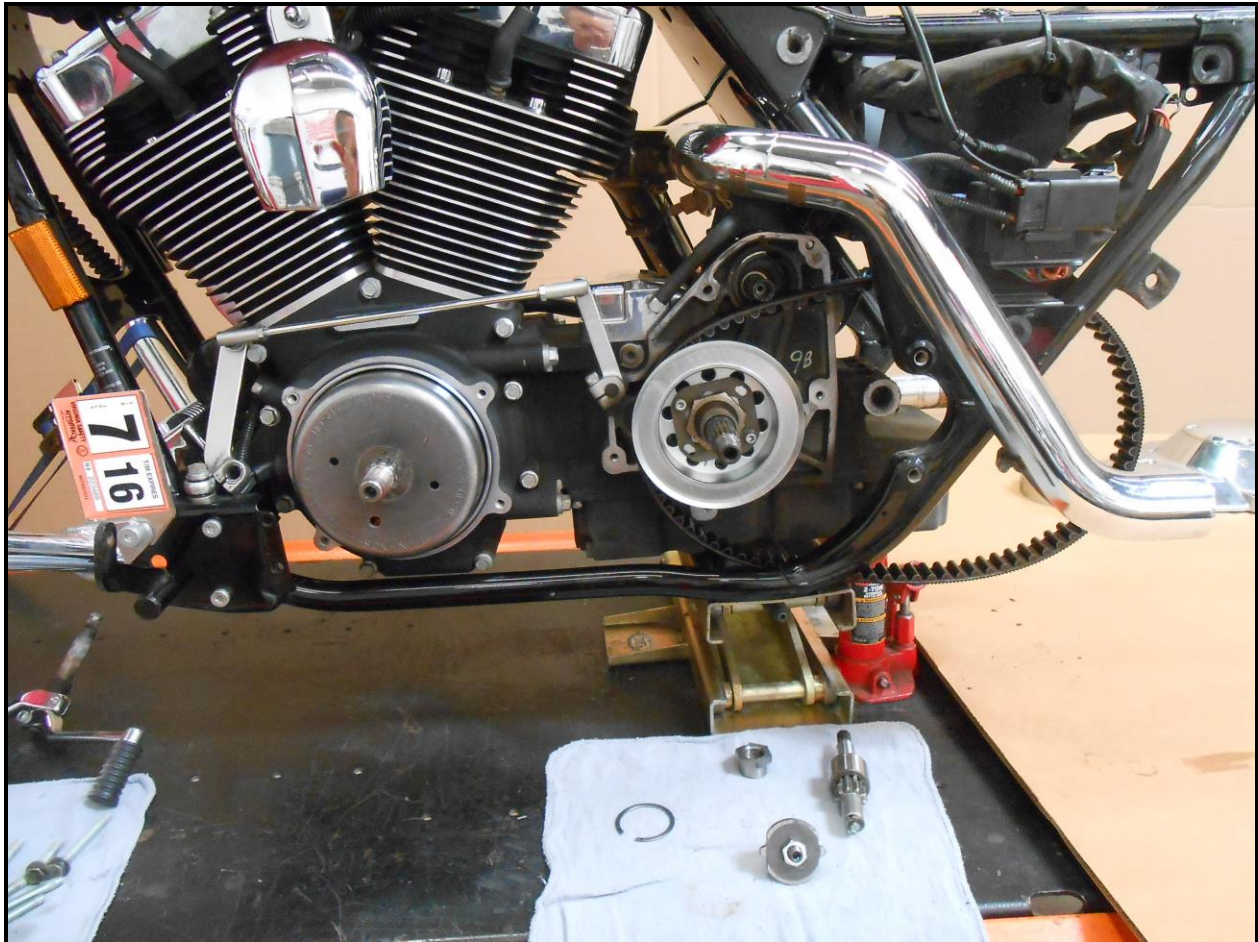

3. Apply silicone sealant to the Crank Case around the two rearward holes.
4. Apply silicone sealant to the Transmission Case around all three holes.
5. Apply silicone sealant to the threads of all five 5/16 - 18 HHCS with a Lock Plate.
6. Place the Primary Chain Case into position over the Crank Case and against the Transmission Housing.

- 7. Start the two 5/16 – 18 x 1 ¾ HHCS with two 5/16 flat washers into the two outer holes of the Primary Chain Case.**
- 8. Start two 5/16 – 18 x 1 ¾ HHCS with two Lock Plates into the two inner holes of the Primary**
- 9. Start three 5/16 – 18 x 3 HHCS with three Lock Plates into the three holes of the Primary Chain Case to Transmission Housing Joint.**
- 10. Tighten the Second 5/16 – 18 HHCS to 18 – 21 ft-lbs in the following sequence.**
  - a. Lower front Crank Case**
  - b. Upper rear Crank Case**
  - c. Upper front Crank Case**
  - d. Lower rear Crank Case**
  - e. Front Transmission**
  - f. Middle Transmission**
  - g. Rear transmission**
- 11. Bend one tab on each Lock Plate against a flat on the 5/16 – 18 HHCS.**
- 12. Place starter into position.**
- 13. Insert the Jack Shaft Assembly into the splined Coupling**
- 14. Insert the Jack Shaft Bolt into the Jack Shaft. Ensure the key on the Lock Plate aligns with the slot in the Jack Shaft. While holding the Pinion Tighten the Jack Shaft Bolt to 60 – 80 in-lbs.**
- 15. Bend tab on the Lock Plate against flat on the Jack Shaft Bolt.**
- 16. Install Alternator Rotor Spacer onto the Engine Sprocket Shaft if present.**
- 17. Install the Clutch, Primary Chain, compensating Sprocket, and Shaft Extension as one assembly. Start the Clutch onto the Main Shaft first. Then align the splines of the Engine Sprocket Shaft with the splines in the Shaft**

Extension. Now align the splines in the Clutch with the splines on the Main Shaft.

18. Clean off old Loctite then apply two drops of Loctite 262 to the threads of the Compensating Sprocket Nut and Clutch Hub Main Shaft Nut.
19. Install the Sliding Cam and Sprocket Cover onto the Shaft Extension. Install the Compensating Sprocket Nut and hand tighten.
20. Install the LEFT HAND threaded Clutch Hub Main Shaft Nut and hand tighten.
21. Ensure the Primary Chain Adjuster is resting flat on the Inner Primary Cover.
22. Using the Primary Drive Locking Tool. Place the large flat surface against the upper strand of the Primary Chain, insert stepped portion of the Primary Drive Locking Tool into the Clutch Sprocket. Tighten the Compensating Sprocket Nut to 75 FT-LBS.
23. Tighten the sprocket nut an additional 45 to 50 degrees. (50 degrees MAXIMUM)
24. Using the Primary Drive Locking Tool. Place the large flat surface against the upper strand of the Primary Chain, insert stepped portion of the Primary Drive Locking Tool into the Compensating Sprocket. Tighten the Clutch Hub Main Shaft Nut to 70 – 80 FT. - LBS.. **WARNING:** This nut is LEFT HAND threaded.
25. Remove the Primary Drive Locking Tool.
26. Place the Clutch Release Plate into the Clutch with the stamped word “OUT” facing outwards.
27. Install the Retaining Ring into the bore of the Clutch Hub. Ensure the Retaining Ring is fully seated in to the Clutch Hub groove.
28. Adjust free play in the Primary Chain by raising the Primary Chain Adjuster Shoe until there is only  $5/8$  –  $7/8$  inches of free play on the center of the upper strand. Once

free play measurement is achieved tighten the Primary Chain Adjuster Captive Bolt to 25 ft-lbs.

Picture below shows special tools needed:

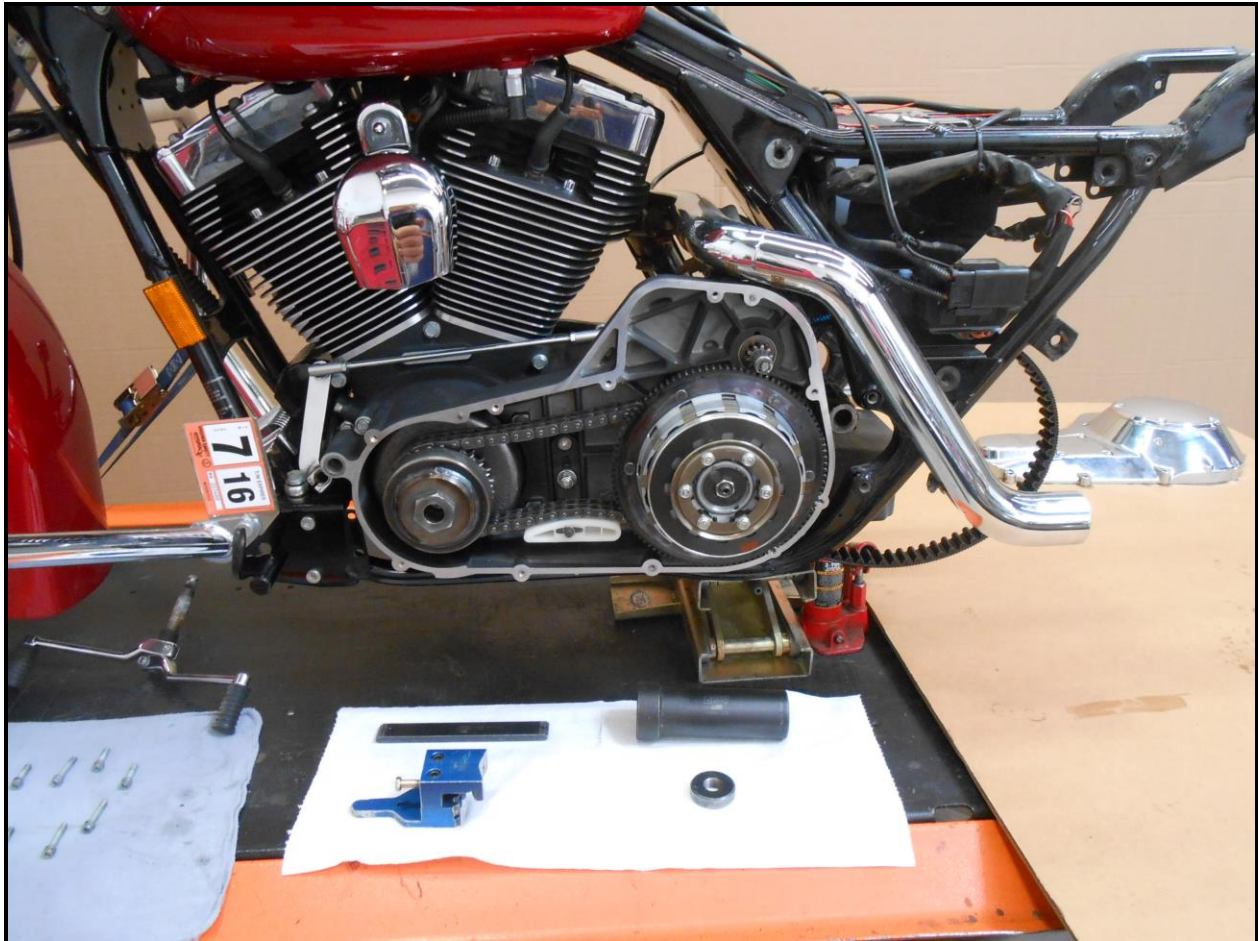

29. Hang new Primary Chain Case Cover Gasket on Dowels.
30. Install the Outer Primary Chain Case Cover over the Primary Chain Case Cover Gasket.
31. Start ten  $\frac{1}{4}$  - 20 SHCS with  $\frac{1}{4}$  flat washers into the Outer Primary Chain Case Cover.

- 32. Tighten the  $\frac{1}{4}$  - 20 SHCS to 84 – 108 in/lbs in the order below. Starting from the Drain Plug and going clockwise around the Primary Chain Case Cover:**
  - a. Drain plug**
  - b. Long  $\frac{1}{4}$  - 20 socket head cap screw (1)**
  - c. Short  $\frac{1}{4}$  - 20 socket head cap screw (3)**
  - d. Short  $\frac{1}{4}$  - 20 socket head cap screw (5)**
  - e. Short  $\frac{1}{4}$  - 20 socket head cap screw (6)**
  - f. Short  $\frac{1}{4}$  - 20 socket head cap screw (4)**
  - g. Long  $\frac{1}{4}$  - 20 socket head cap screw (2)**
  - h. Short  $\frac{1}{4}$  - 20 socket head cap screw (8)**
  - i. Long  $\frac{1}{4}$  - 20 socket head cap screw (10)**
  - j. Long  $\frac{1}{4}$  - 20 socket head cap screw (9)**
  - k. Long  $\frac{1}{4}$  - 20 socket head cap screw (7)**
- 33. Apply thread sealant to the Drain Plug and reinstall.**
- 34. Remove five  $\frac{1}{4}$  - 20 torx HCS and the Clutch Inspection Cover.**
- 35. Remove the Quad Ring and discard.**
- 36. Fill the Primary Chain case to the bottom of the Diaphragm Clutch Spring with the appropriate lubricant.**
- 37. Swab all lubricant from the Quad Ring groove in the Primary Chain Case Cover. Install new Quad Ring with the nubs contacting the walls of the groove.**
- 38. Using the five  $\frac{1}{4}$  - 20 torx HCS replace the Clutch Inspection Cover. Progressively tighten the five screws to 84 – 108 IN-LBS in a criss-cross pattern.**
- 39. Reinstall the shift rod rubber.**
- 40. Reinstall the Inner and Outer Shift Levers.**
- 41. Using one  $\frac{1}{2}$  - 13 socket head cap screw,  $\frac{1}{2}$  split lock washer, and  $\frac{1}{2}$  flat washer Replace the Front Drivers Footboard mount. Using two  $\frac{5}{16}$  – 18 HHCS with  $\frac{5}{16}$  split lock washers and one  $\frac{5}{16}$  – 18 hex nut. Install the Rear Drivers Footboard mount.**

## **Modification of Motorcycle Frame:**

**1. Cut the rear of the Motorcycle frame as Shown.**

**Silver line for reference:**



**After cutting, basically flush with the sheet metal rear tabs:**





## Rear Suspension Unit Installation:

1. Install Drivers Backrest Mount using four 5/16 fasteners.
2. Install stud plate with plastic washers and nuts previously removed from rear fender.

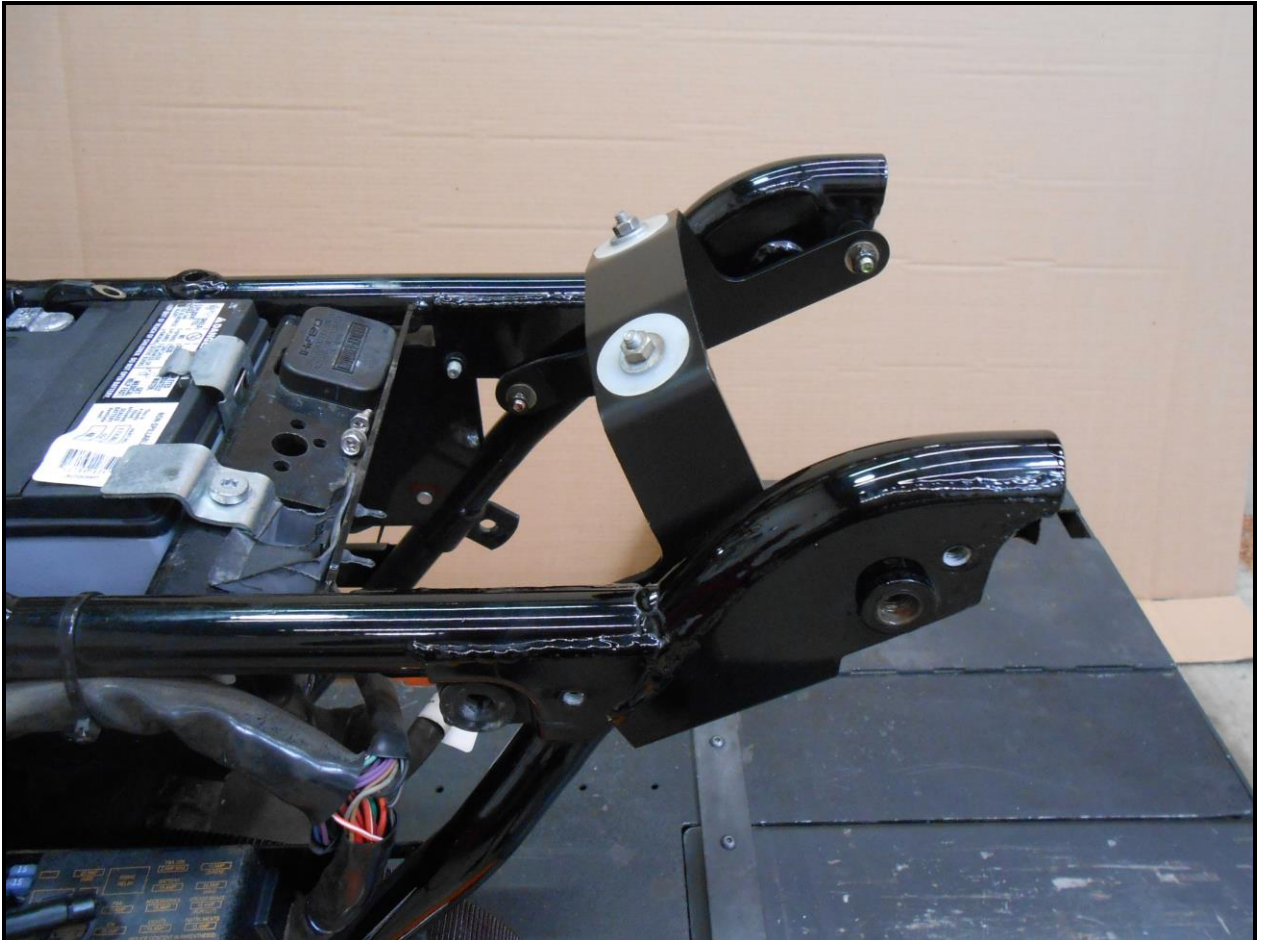

3. Place Suspension Unit behind prepared motorcycle as shown below. Using a small Jack under the Oil Pan and a Jack under the Suspension unit.
4. Slide Suspension unit as far forward as possible to install Drive Belt onto Drive Sprocket.



5. Raise the front Jack until the hole through the Transmission for the Swing arm Pivot is in the center of the two holes for the Rear Fork Bracket.
6. Apply a light coating of Anti Seize Compound to the Swing Arm pivot Shaft. Insert the shaft from the right. The Swing Arm Pivot Shaft will go Through the Right Drive Support Bushing then the Transmission and finally through the Left Drive Support Bushing.

7. Remove and discard Chrome Cap from the Rear Fork Brackets.
8. Install the Right Rear Fork Bracket using the OEM two 7/16 – 14 HHCS. Ensure the locating pin on the back side of the Right Rear Fork Bracket is in the mating hole of the Rubber Mount.
9. Install the Left Rubber Mount onto Swing Arm Pivot Shaft. Apply thread locking agent to the threads. Loosely install the Rear Fork Pivot shaft Nut and Cup Washer onto the Rear Fork Pivot Shaft.
10. Install the Left Rear Fork Bracket using the OEM two 7/16 – 14 HHCS. Ensure the locating pin on the back side of the Left Rear Fork Bracket is in the mating hole of the Rubber Mount.
11. Using two 1/2 - 13 SHCS with thread locking agent. Install the Intermediate Mount to the upper Air Shock mounting holes. Do not tighten.
12. Torque the Rear Fork Pivot Shaft Nut to Specification.
13. Remove two 7/16 – 14 HHCS on the Left Rear Fork Bracket. Install the Sub Frame Adapter with two 7/16 – 14 fasteners as shown. Apply thread locking agent. Torque to spec.
14. Repeat above steps for the Right Rear Fork Bracket.

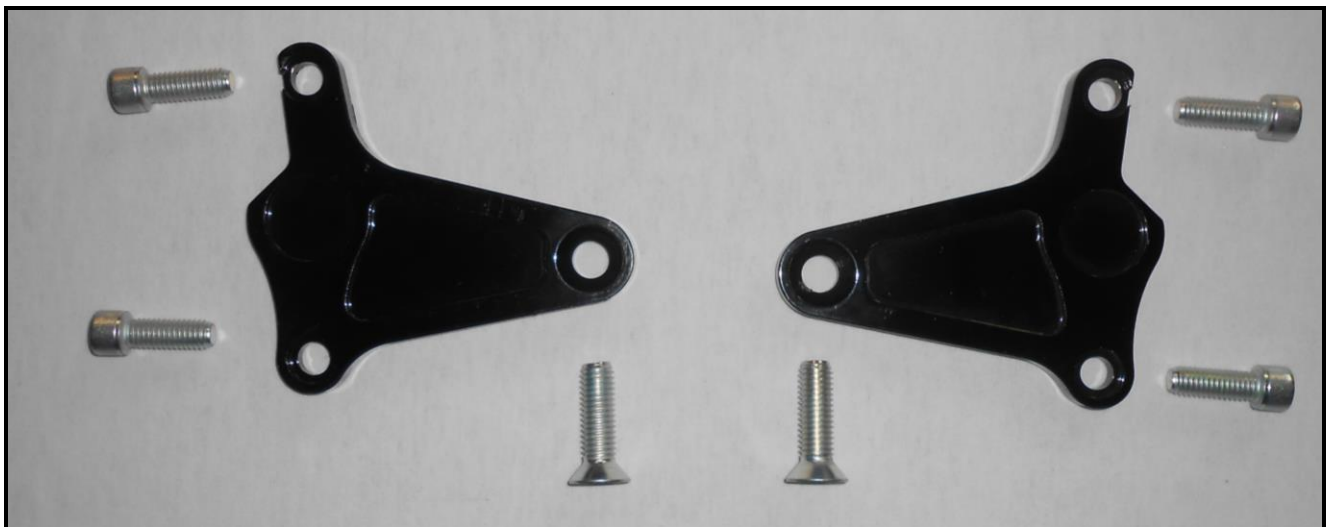

## Frame Mount Installation:

1. Install the Left Frame Mount with one 1/2 - 13 Flat Head thru the Frame Adaptor threading into the forward boss. Use thread locking agent.
2. Insert two 5/16 - 18 x 1 3/4 SHCS into the upper and lower bosses of the Frame Mount then thru the tabs on the Suspension unit.
3. Using two 5/16 flat washers and two 5/16 - 18 nyloc nuts tighten the three SHCS.
4. Repeat for the Right Frame Mount.
5. Now Torque the Shock bolts left loose from before.

**RED** #'s refer to the steps:

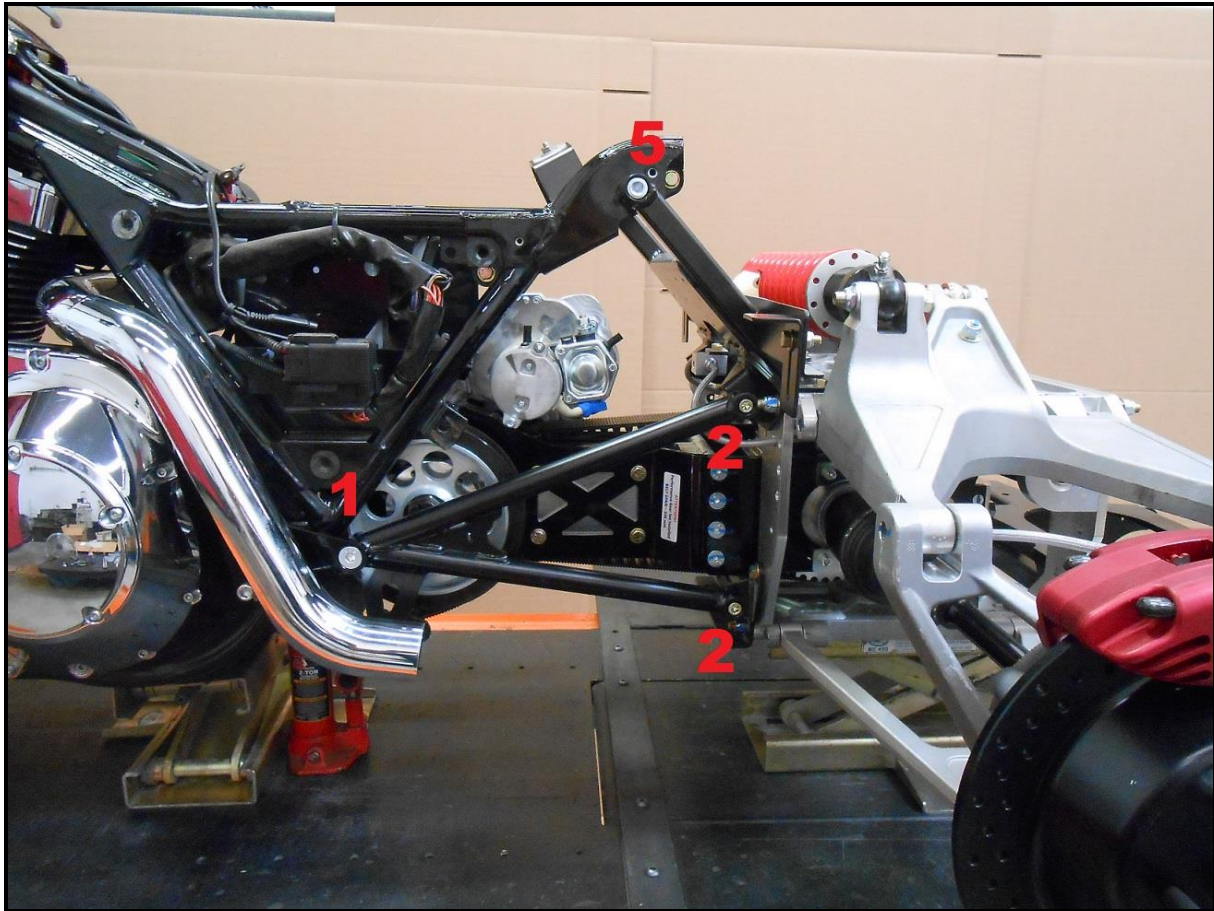

6. Tighten the four SHCS left loose by CSC to allow suspension alignment. See **RED** arrows below.

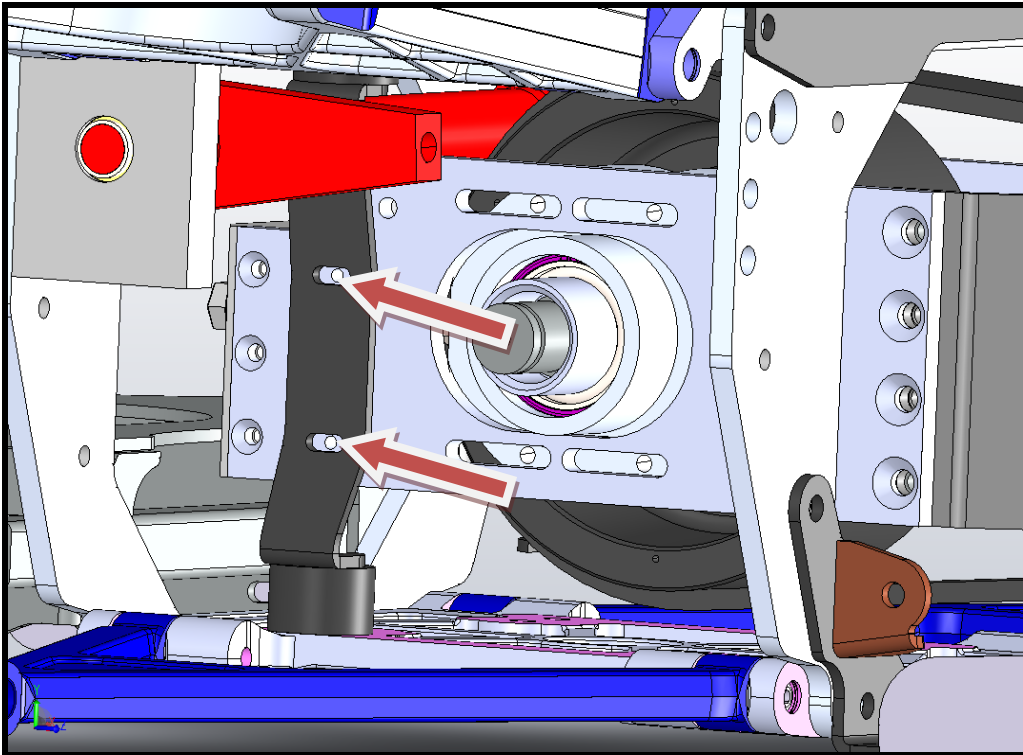

## Brake Line Installation:

**NOTE: if ABS equipped refer to separate instructions.**

1. Remove the two wire clips from the rear stop lamp switch.
2. Remove the Banjo Bolt from the Rear Master Cylinder.
3. Remove the Rear Brake Hose.
4. Remove the Rear Stop Lamp Switch from the junction in the Rear Brake Hose.
5. Re-clamp the Wire Harness Clips that were previously used to clamp the Rear Brake Hose.
6. Reinstall the Rear Stop Lamp Switch into the new Rear Brake Hose. Use proper thread sealant on the Rear Stop Lamp Switch.
7. Route new Rear Brake Hose with the bent banjo fitting towards the Rear Master Cylinder. The Rear Brake line will be on the outside of the Rear Master Cylinder. See Photo.



**2008 Models:** Reuse OEM banjo bolt.

8. Using the Short Banjo Bolt and two Crush Washers. Install the bent banjo fitting onto the Rear Master Cylinder. Torque to specification.

9. Route the Rear Brake Hose along the Frame.
10. Use Cable Ties to hold the Rear Brake Hose to the Frame.
11. Install the two wiring connectors back onto the Rear Stop Lamp Switch.

### **1999 – 2006 Models**

12. Place the rubber coated Band Clamp around the Rear Brake hose above the Rear Stop Lamp Switch Junction.
13. Using the OEM 10 – 24 flanged hex head cap screw. Attach the rubber coated Band Clamp to the Right Rear Fork Bracket. See Photo.

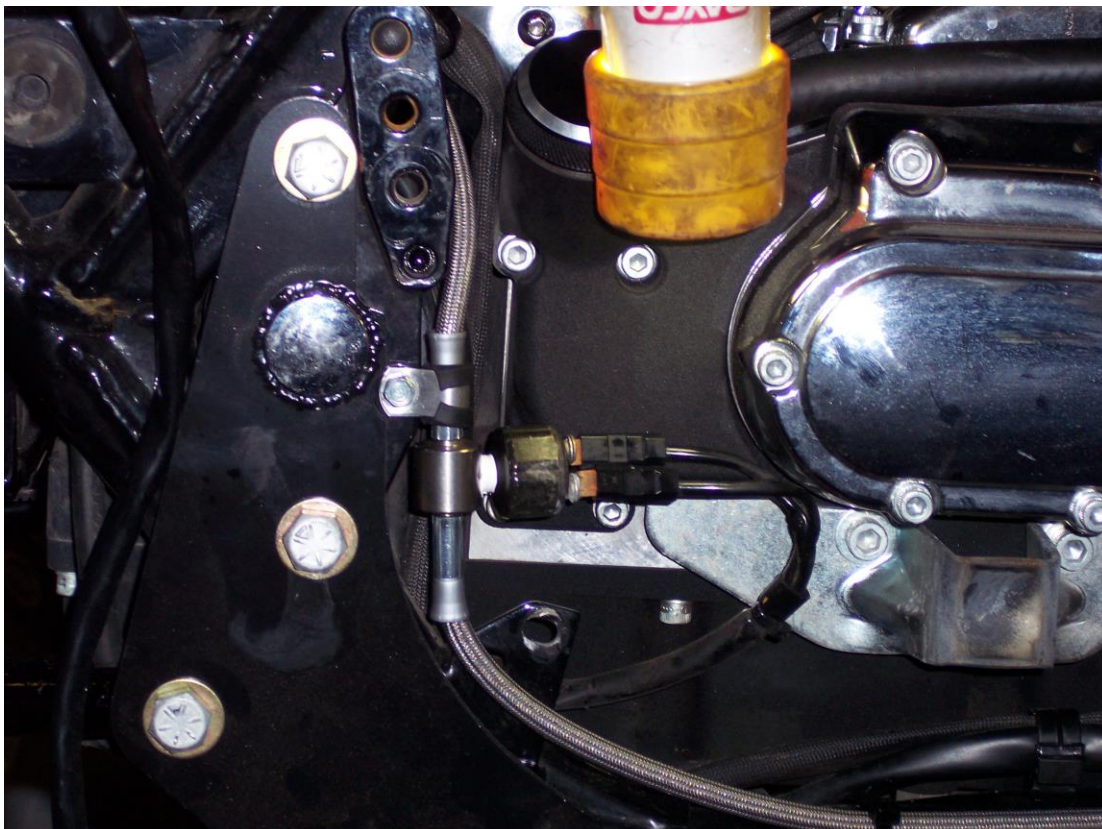

14. Route the Rear Brake Hose to the inside of the Frame and onto the Distribution Block.
15. Using the Long Banjo Bolt and two Crush Washers. Install the straight banjo fitting onto the Distribution Block.
16. Using Cable Ties secure the Rear Brake Hose to the Frame.

## Brake bleeding procedure:

**NOTE: if ABS equipped refer to separate instructions.**

1. Using correct brake fluid, fill Rear Brake Master Cylinder Reservoir.
2. Using a vacuum bleeder, follow this procedure **carefully**.
  - a. Rear caliper rear bleed valves outsides first then insides on each side.
  - b. Rear caliper front bleed valves outsides first then inside on each side.
3. Hand bleed the system using the above sequence. Until all air is removed from the lines.
4. Allow the bike to set for a minimum of 20 minutes and recheck the pedal travel.
5. If there is excessive pedal travel on the first pump, repeat steps 3 and 4.





## ABS brake equipped bikes:

1. Route the ABS sensor wire up to the ABS control module and plug it into the OEM wheel speed sensor plug.
2. Confirm that the air gap between the sensor and the trigger wheel is .050 of an inch.
3. Use cable ties to hold the rear brake hose and the sensor wire to the frame mount(s).

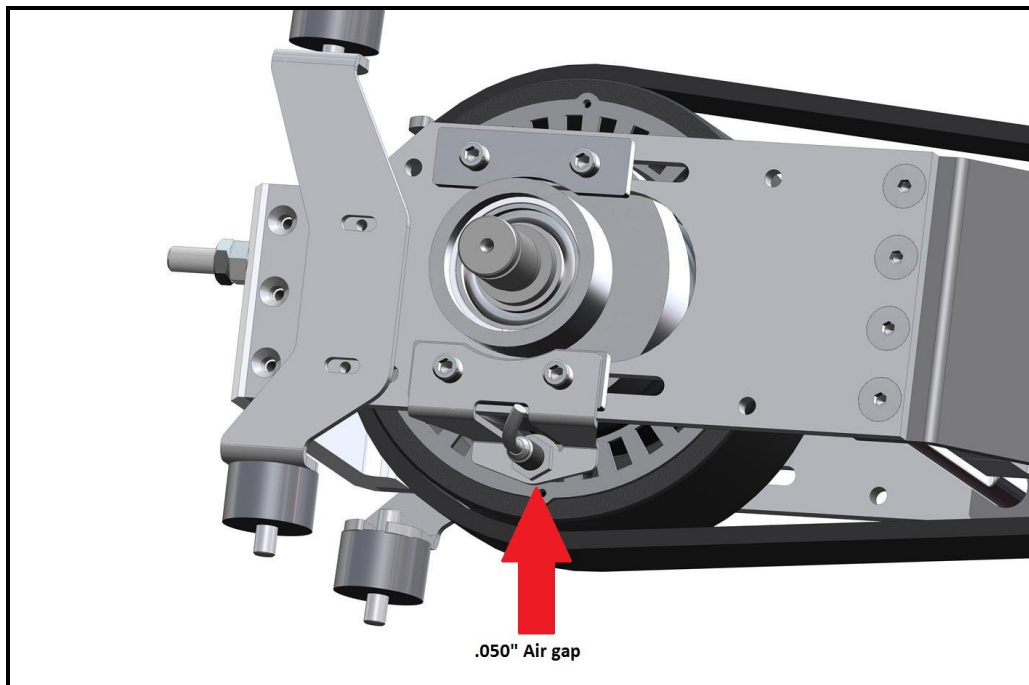

## **Link to CSC Belt Tensioning video:**

<http://www.californiasidecar.com/support.html>

## **Setting up the Sonic Tension Meter:**

1. Turn power on, Push Select then 1.
2. Using the charts below in Front and Rear belt tensioning push Mass then the numbers, Width and so on.
3. For the Rear belt push Select then 2. Reverse belt can be number 3 and so on.

## **Using the Sonic Tension Meter:**

1. The microphone placement over the belt is critical.
  - a. The microphone should be in the middle of the belt width-wise.
  - b. The microphone should be equally in-between the two Sprockets.
  - c. The microphone should be between  $\frac{1}{4}$  and  $\frac{1}{2}$  an inch above or below the Belt.
2. Turn the Sonic Tension Meter on.
3. Ensure that the correct setting is displayed on the LCD screen.
4. Push MEASURE then gently tap the Belt with a wrench while holding the microphone in the correct position. A measurement in Lbs. of single span tension should display. If not continue tightening the Belt until a reading is displayed.
5. In noisy environments the Sonic Tension Meter may display errant numbers. If so use in a quieter area.
6. Always take at least THREE readings of the Belt tension and average the THREE readings to determine the actual tension of the Belt.

## Tensioning the Front Drive Belt:

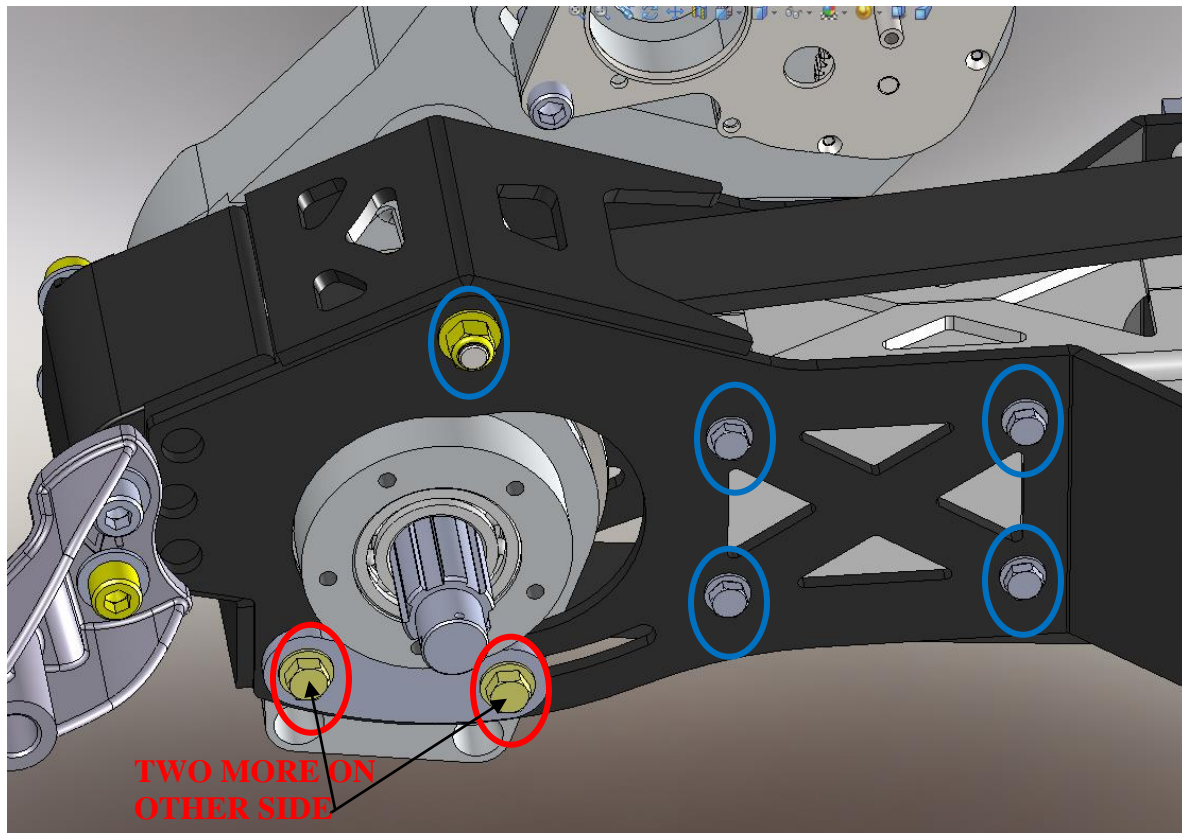

1. Loosen the four clamping HHCS two per side. **RED** circles.
2. Tighten the Rear Drive Belt adjuster nuts until the slack is taken up on the Front Drive Belt.

3. Use the correct setting on the Sonic Tension Meter.

**1999 - 2006**

Mass 7.9 g/m

Width 28 mm

Span 331 mm

**2007 - 2008**

Mass 7.9 g/m

Width 28 mm

Span 341 mm

**Performance Gear**

Mass 7.9 g/m

Width 28 mm

Span 338 mm

4. Check Front Drive Belt tension.

28MM Belt: 130 - 150 lbs. single span tension.

5. Once the correct belt tension is achieved tighten all fasteners, Eight HHCS and one nyloc nut. **RED** and **BLUE** circles shown above

6. Verify belt tension.

If incorrect start back at step 1. If correct proceed.

## Gravel Pan:

If installing GRD EFX install the middle mount now.

1. Install the chrome clamps on the crash bar.
2. Lay GRD EFX bar in place under the motorcycle frame.
3. Install the front of the bar in the chrome clamps with two 3/8-16 x 1 1/4 HHCS, flat washers and nyloc nuts.
4. Raise the rear of the bar up to the Frame Mount tabs and secure with two more of the same HHCS.



5. Install Gravel Pan with three 1/4-20 x 3/4 HHCS, flat washers and nyloc nuts in the rear. Bolts up through and nuts on top.
6. Secure the front with two of the same HHCS to the Frame Mount Tabs.



## Reinstall Exhaust Head Pipe:

1. Remove Exhaust Gaskets from Cylinder Heads.
2. Install new Exhaust Gaskets.
3. Reinstall the Front and Rear Cylinder Head Pipes and Heat Shields.

**1999 - 2006 Models:** Install the exhaust spacer between the head pipe and trans exhaust mount use longer 5/16 HHCS provided to secure head pipe to its mount.

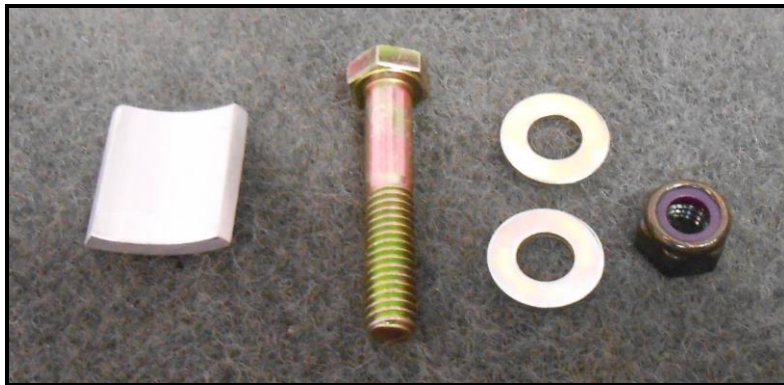

## Exhaust Mount Installation:

1. Place the Left Exhaust Mount against the left side of the Body Frame. Shown in **Green**.
2. Install three 5/16 - 18 x 1 1/4 HHCS and three 5/16 flat washers thru the Exhaust Mount and the Body Frame.
3. Install Trailer Hitch now if equipped.
4. Loosely install three 5/16 flat washers and three 5/16 - 18 nyloc nuts.
5. Install the right side with the same procedure.

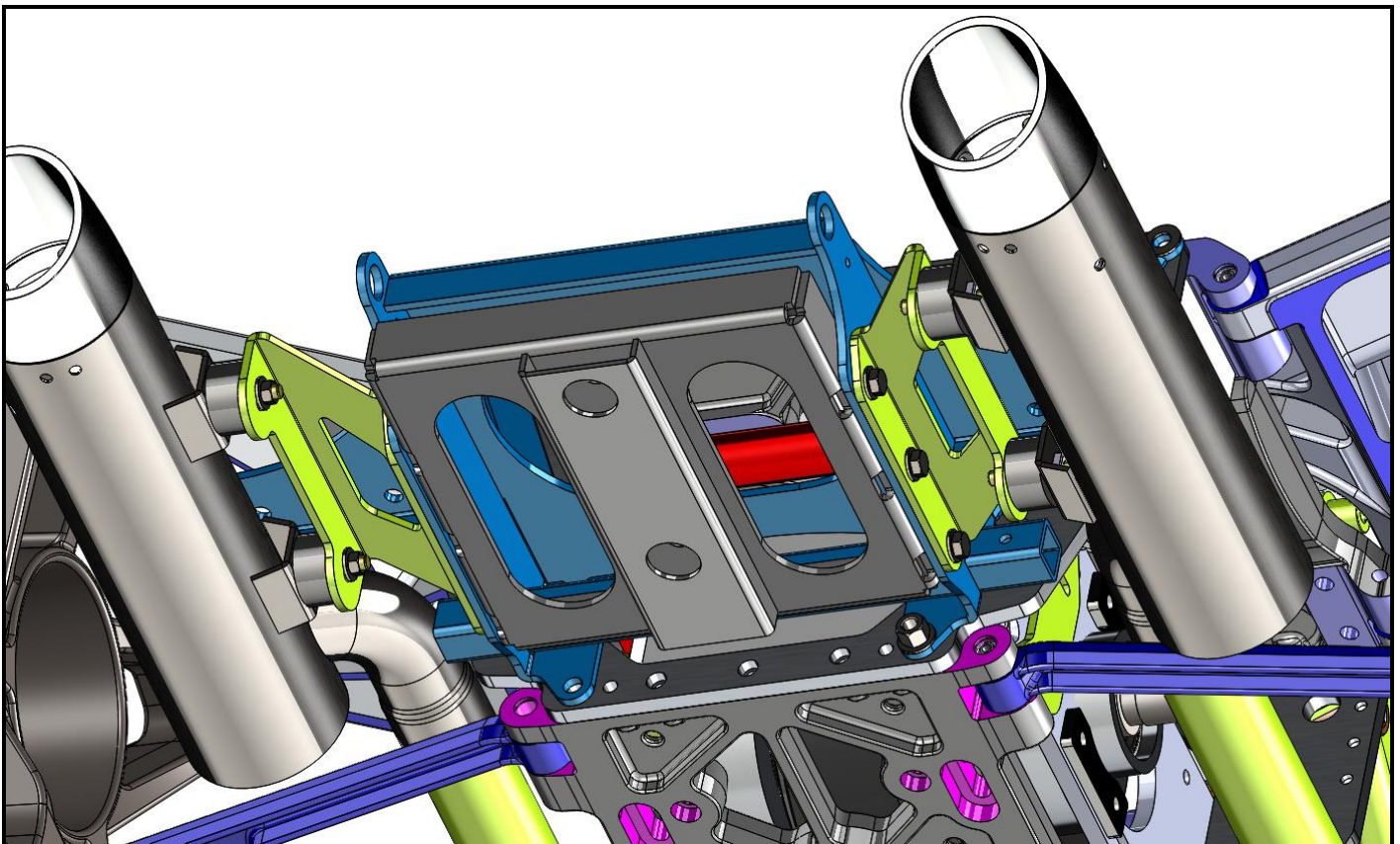

## **Exhaust Installation:**

- 1. Install the Rubber Mounts onto the Mufflers.**
- 2. Place one stock Muffler Clamp onto each Rear Exhaust Pipe.**
- 3. Slide the Left Rear Exhaust Tail Pipe onto the Left Exhaust Pipe.**

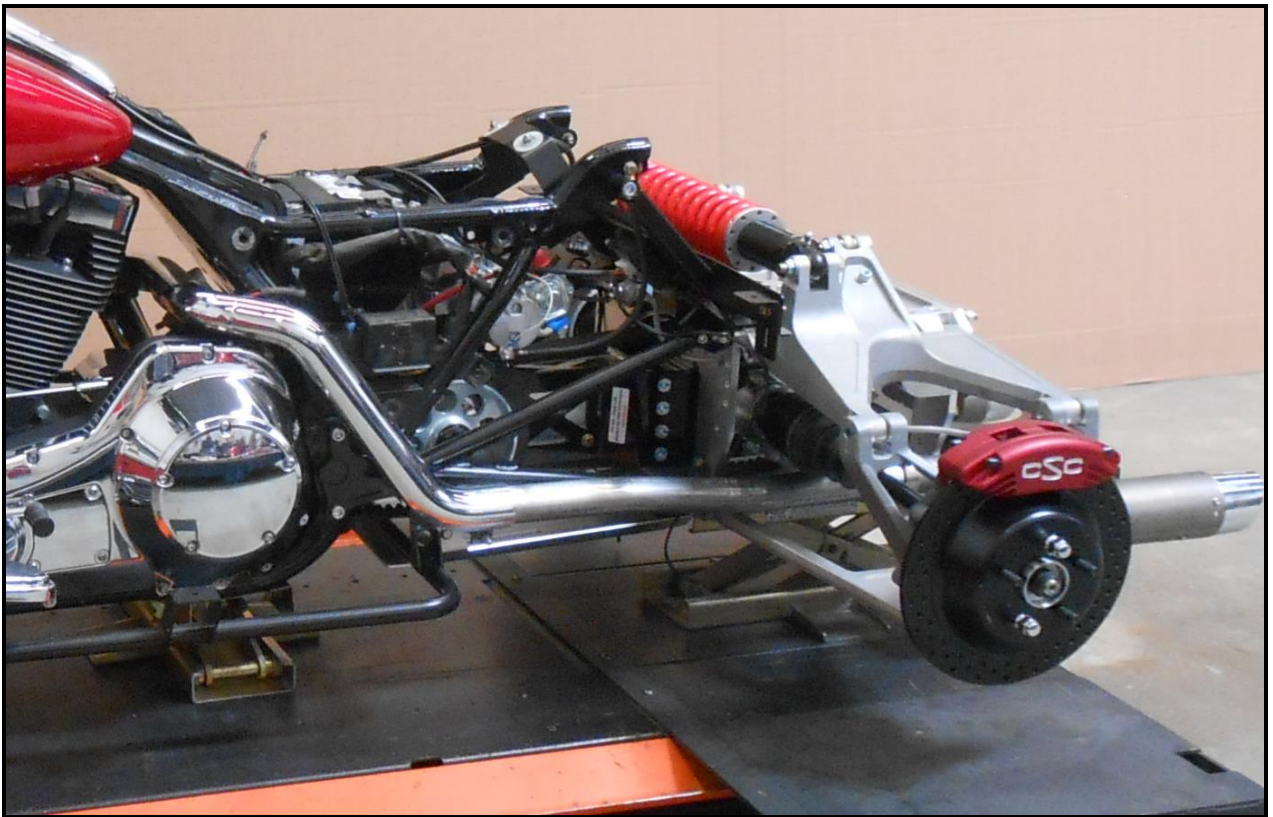



4. Slide the Right Rear Exhaust Pipe onto the Right Exhaust Pipe.
  5. Place two new Exhaust Clamps onto the Mufflers and slide the mufflers onto the Left and Right Exhaust Pipes.
  6. Install four 5/16 - 18 nyloc nut onto the Rubber Mounts.
  7. Just secure but not tighten the Mufflers so they are as low as possible. Tighten the Exhaust Clamps.
- Note:** Insure there is a 1/2 inch air gap around the inner C.V. joint

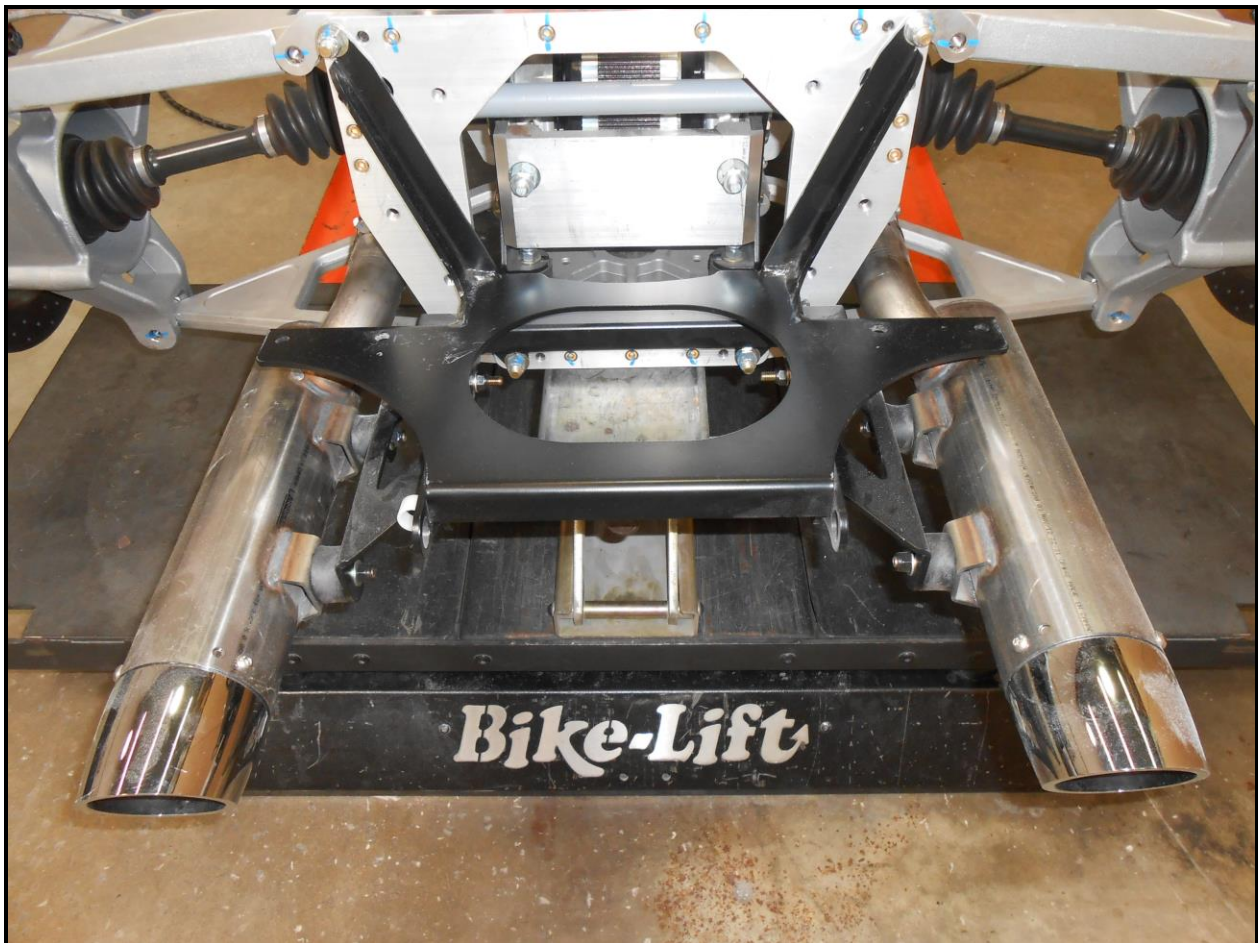

## Tensioning the Rear Drive Belt:

1. See diagram below.

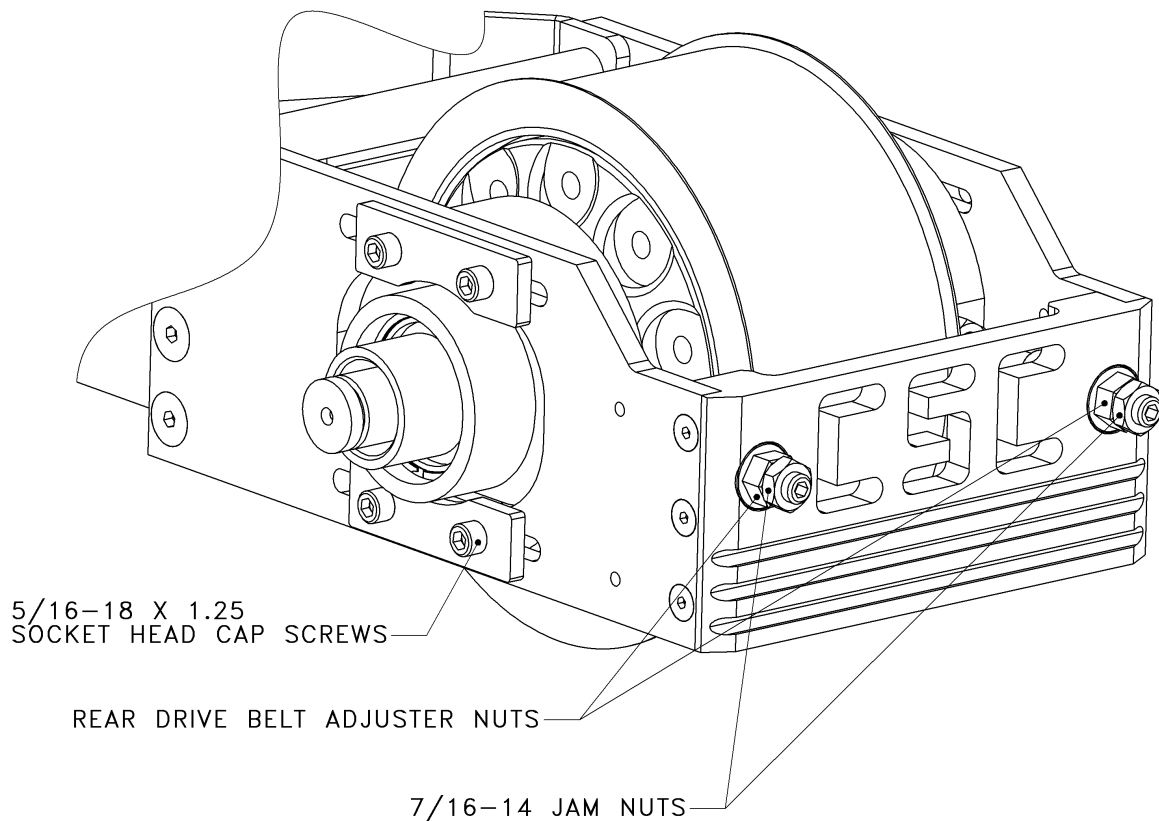

2. Tighten the Rear Drive Belt Adjuster nuts until the slack is taken up on the Rear Drive Belt.

3. Use the correct setting on the Sonic Tension Meter.

MASS 007.9 g/m

WIDTH 050.0 mm/R

SPAN 0442 mm

4. Check Rear Drive Belt tension.

5. 50mm belt: 130 - 150 lbs. of single span tension.

6. In the next step you are going to run the engine. Please be aware of the safety of all those involved. Make sure you have at least two lug nuts on each rotor and that they are tight.

7. To finish alignment, the belt must have at least 0.040in clearance between edge of belt and fence on front Rear

**Drive Sprocket. Check this by starting the engine and placing it in second gear and simply let the engine idle. Checking the alignment by eye and centering the belt as it spins. If belt has correct clearance, go to **step 9**. If it does not have clearance, proceed to **step 8**.**

- 8. Use the Left and Right Rear Drive Belt Adjuster Nuts to align belt in order to achieve the necessary belt clearance. NOTE: The belt will always track to the side of the sprocket that is the loosest. Repeat step 4.**
- 9. Once the correct belt alignment and single span tension is achieved, tighten the eight 5/16 – 18 x 1 ¼ SHCS that go into the Carrier Bearing Support Housings.**
- 10. Install two 7/16 – 14 hex jam nuts onto the Rear Drive Belt Tensioning Studs and tighten.**
- 11. Verify belt tension and alignment.**
- 12. If all is correct move on to next step. If not loosen clamping bolts and return to step 4.**

### **Service Limits on Drive Belts:**

**Service limit on the Front Drive Belt is 130 - 150 lbs.**

**Service limit on the Rear Drive Belt is 130 - 150 lbs.**

## Suspension Setup:

Use this chart to select the correct spring preload.

Rotate the adjuster nut on the shock until the spring is set to the desired length. Now tighten the set screw on the adjuster nut or tighten the lock nut on the fully adjustable shock.

**Load:** Typical weight the customer adds to the stock trike. This includes riders, luggage, and weight of a trailer tongue.

When in doubt assume a higher weight than actual.

**Length:** Suggested length the spring should be adjusted to with the suspension completely unloaded and the preloader adjusted all the way out.

DAYTONA								
SHOCK with RED SPRING								
	LOAD	LENGTH		LOAD	LENGTH		LOAD	LENGTH
250 LB/IN SPRING	100	13 1/16	300 LB/IN SPRING	100	13 1/4	350 LB/IN SPRING	100	13 7/16
	200	12 7/8		200	13 1/16		200	13 1/4
	300	12 5/8		300	12 7/8		300	13 1/8
	400	12 5/16		400	12 5/8		400	12 15/16
	500	12 1/8		500	12 7/16		500	12 3/4
				600	12 1/4		600	12 5/8
							700	12 1/2
							800	12 3/8

Install preload adjuster now if equipped. Refer to separate installation instructions.

These lengths are only estimates. If you would like to confirm a correct setting, load the completed trike to the customers typical riding situation and measure from the ground to the middle of the lower suspension plate. The center hole should be 5.75" – 6.25" from the ground.

**Attention:** This is the only suspension adjustment needed. All other settings are factory set and should not be tampered with. There is no need to remove trike from the lift to check camber, toe, or the drop links.

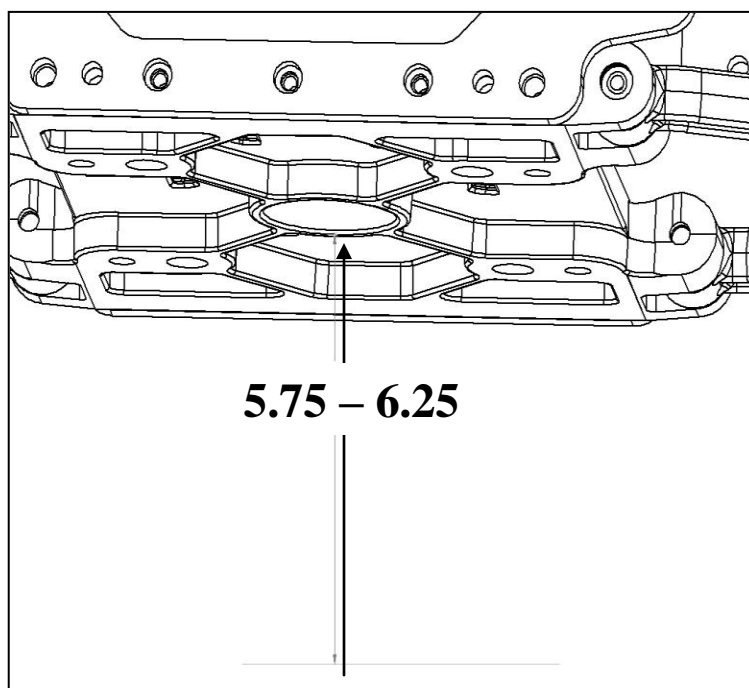

## **Body installation:**

- 1. Lower the body onto the trike with the front of the body pointing downward until it comes to rest onto the upper tray and body frame as shown.**
- 2. Install Side Covers.**



## **Tour Pak Installation:**

- 1. Apply silicone sealant to both sides of the five rubber spacers and in the holes in the body.**
- 2. Place the rubber spacers over the five holes predrilled in the body.**
- 3. Lower Tour Pak down onto the rubber spacers.**
- 4. Install five 1/4 - 20 HHCS with flat washers thru the Tour Pak then the rubber spacer and finally thru the predrilled holes in the body.**
- 5. Install fender washers and 1/4 - 20 nyloc nuts from the inside of the body.**
- 6. Adjust Tour Pak into alignment and tighten bolts.**
- 7. Reconnect Tour Pak wiring.**

- 8. Route the Trunk Emergency Release cable along the right side of the Frame and tie just behind the Right Side Cover.**
- 9. If installing Ground Effects see attached instruction packet.**
- 10. Connect Body Wiring Harness connector under the Frame to the Rear Fender Wiring Harness Connector.**
- 11. Route the Fuse-able Link and the White Wire towards the Battery.**



## **Trike body alignment:**

- 1. The Trike Body can move left, right, forward, backward, up, down, and angled. Shimming with the provided 1/4 and 1/8 Rubber Washers may be required to get the Trike Body into alignment.**
- 2. First raise the front of the body to obtain the vertical location around the Side Covers.**
- 3. Then slide the body front to back to get the horizontal location around the Side Covers.**
- 4. With the body temporarily held into place, raise the adjustable 90° body support brackets until they seat against the body's inner liner.**
- 5. Tighten the two 5/16 – 18 x 3/4 HHCS and two 5/16 – 18 nyloc nuts on the Adjustable 90° Support Brackets.**
- 6. Center the Trike Body left to right with the Mufflers and Side Covers.**
- 7. Use a Carpenters Square on the rotors and measure to the trike body wheel wells.**



## **Securing the trike body:**

- 1. Using a 5/16 twist drill, drill up through the Adjustable 90° Body Support Brackets.**

**Note:** A small section of Trike Body Carpet has not been glued at the location of the Trike Body Frame mounting tabs to allow removal of the bolts used in shipping, and installation of the Trike Body mounting hardware. The predrilled bolt holes may need to be enlarged or relocated for Trike Body attachment to the Trike Body Frame mounting tabs. If relocation is necessary, the preexisting holes will need to be sealed with silicone sealant.

- 2. Using a 5/16 twist drill, drill up through the Trike Body Frame mounting tabs.**
- 3. Insert two 5/16-18 x 1 1/4 HHCS, two 5/16 x 1 1/2 fender washers, and rubber washers if necessary through the holes drilled in step 3.**
- 4. Insert two 5/16-18 x 1 1/4 HHCS and two 5/16 x 1 1/2 fender washers through the adjustable 90° body support brackets.**
- 5. Install four 5/16-18 nyloc nuts and four 5/16 flat washers onto the four 5/16-18 x 1 1/4 HHCS and tighten.**
- 6. Re-align the Mufflers into the Trike Body cutout and tighten all the Exhaust Clamps and hardware.**

## **Reassembly of the motorcycle:**

- 1. Replace the 15 AMP “lights” fuse with the 20 AMP fuse provided.**
- 2. Reinstall the right and left Side Covers.**
- 3. Connect the red wire with Fuse Holder to the Positive Battery terminal.**
- 4. Reconnect the negative battery terminal and the new white wire from the Tike Body Wiring Harness.**
- 5. Replace the Seat and  $\frac{1}{4}$  - 20 Phillips head screw.**

## **Final Reassembly of the motorcycle:**

- 1. Reinstall the wheel and tire assemblies with ten m12 x 1.5 ET conical lug nuts. Torque to 75 ft-lbs.**
- 2. Recommended tire pressure**
  - 15 & 16” wheels – 28 psi**
  - 17” wheels – 25 psi**

**Refer to the Maintenance Schedule on p. 5 for details regarding future service inspections and maintenance.**

**From all of us at California Sidecar.  
Enjoy the ride.**