



KAWASAKI 1700

Vulcan Voyager

Vulcan Vaquero

Vulcan Nomad

**Electric Reverse
Installation Instructions**

REVISED 1 - 2016

**California Sidecar Parts & Technical Support
434.263.8866**

Warnings and considerations:

1. **Disclaimer** - These instructions assume a level of understanding of motorcycle repair and maintenance beyond that of a “beginner” and/or “novice” and California Sidecar cannot be liable for an installer’s failure to understand or follow these instructions as written. Likewise, California Sidecar cannot be responsible if any of the steps are omitted or shortcuts are taken, or parts other than those supplied by California Sidecar, are used in installing this trike kit.
2. **“WARNINGS”** are all printed in bold type and capitalized. They mean to use extreme care in a given step so as not to damage the part, motorcycle, and/or yourself.
3. **Always** wear safety glasses when using hand and/or power tools.
4. When working in and around the fuel system, **always** work in a well-ventilated area, free from sparks and open flames.
5. All directional references to the “right side” and the “left side” are as you were seated on the motorcycle.
6. All directional references to “forward” mean to the front of the motorcycle while “back” means the rear of the motorcycle unless otherwise stated.
7. Please consult the appropriate Service Manual for your motorcycle if further detail is necessary.

INSTALL REVERSE AND ALL ITS PARTS DURING INSTALLATION AND BEFORE THE BODY IS INSTALLED.

Assembly:

1. Once 28 MM and 50 MM belts are tensioned and all clamping bolts are tightened.
2. Check the Tension of the Reverse belt.
3. Sonic Tension Meter specs:
MASS 004.7
WIDTH 021.0
SPAN 0176
4. Reverse Belt Tension:
SINGLE SPAN TENSION: 49-55 lbs.

Wiring:

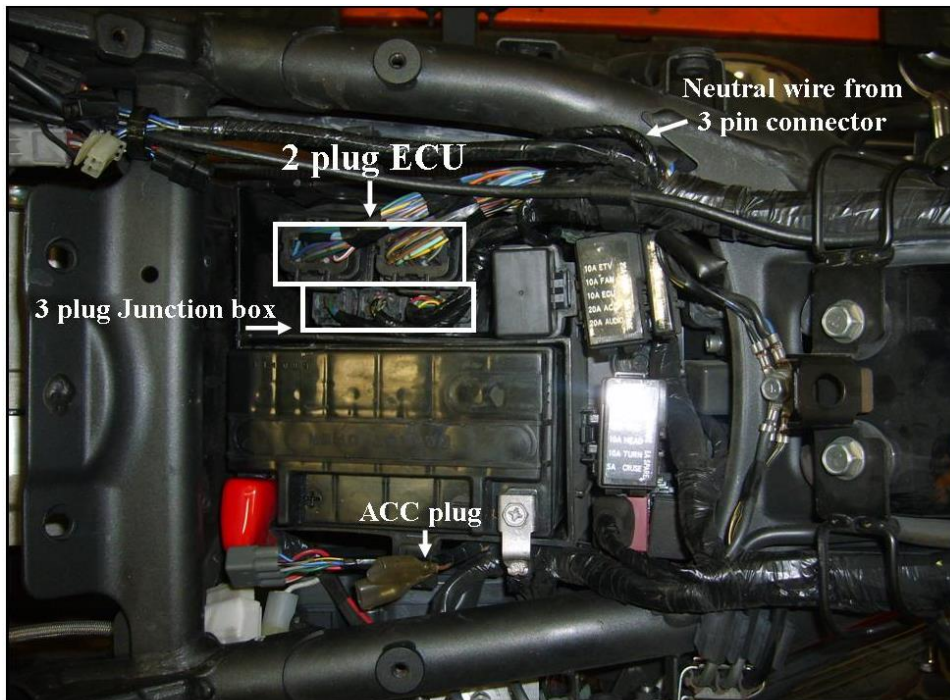

1. Locate the ECU (the 2 plug box) to the left of the battery.

2. Route the reverse harness forward to this area. Pull the yellow, black, and brown wires out of the loom where the green wire already exits. Position that slit in the loom at the front of the ECU.
3. Locate the white wire with red tracer at the ECU (Fuel pump wire) connect it to the green wire using a scotch lock connector.
4. Locate the junction box (the 3 plug box) on top of the ECU.
5. Locate the black wire with red tracer at the junction box (Start button wire) and cut it.
6. Connect that black wire with red tracer at the junction box to the black wire with a butt connector.
7. Connect the other end of that black wire with red tracer that goes to the harness to the yellow wire with a butt connector.
8. Locate the 3 pin connector from the transmission with a green, black/yellow, and light green wire. Connect the light green wire (Neutral wire) to the brown wire with a scotch lock connector.
9. Locate the blue wire (brake light) under the seat at the fender plug. Using a scotch lock, connect to the red/yellow wire.
10. Set the rest of the harness on top of the battery area and continue with the trike installation.

Wiring continued: (after the suspension is installed)

1. Secure Reverse module to Rear Mount Plate with cable ties turned 90°.

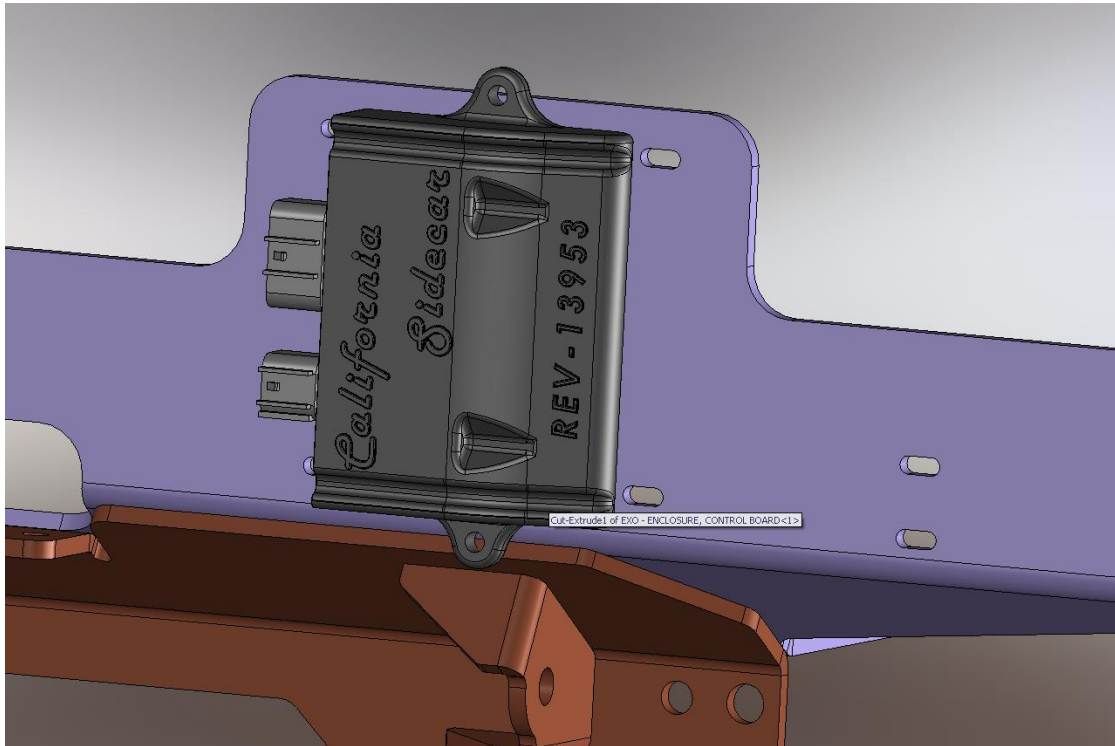

2. Plug both harnesses into the Reverse module.
3. Route the blue and white wires to the Reverse motor.
4. Route the long wire harness up under the seat.
5. Route the red wire to the battery area.
6. Under the seat area there is a brown wire with blue tracer (at the fender plug harness) and it has a double female bullet connector.
7. Using a male bullet connector on the single red wire, plug it into one side of the brown wire with blue tracer connector.
8. Install terminal boot onto red positive cable.
9. Connect the red positive cable to the stud on the Reverse motor solenoid.
10. Using provided cable tie, secure the positive cable to the Reverse motor.
11. Install the black negative cable and white wire to the lower long mounting bolt on the Reverse motor. Route the negative cable to the battery.

- 12. Connect the blue wire to the male spade on the Reverse motor.**
 - 13. Connect the red cable to the positive battery terminal and the black cable to the ground junction just ahead of the battery.**
 - 14. Remove the chrome cover on the gas tank.**
 - 15. Just below and to the right of the key, drill a 1/2 hole for the reverse switch.**
 - 16. Ensure the rubber washer is on the Reverse switch, then insert the wire thru the cover and install nut and tighten.**
 - 17. Connect the harness to the Reverse switch and secure wires with cable ties.**
- Voyager models: route under seat and chrome cover.**
- Nomad models: route under the tank and up to the cover.**
- 18. Ensure that all wires and miscellaneous components are secured to the frame with cable ties.**

Operating the Electric Reverse:

- 1. With the Trike in neutral. Start the engine.**
- 2. Depress the reverse switch and the red LED will light up.**
- 3. Press the start button and the trike will then back up.**
- 4. If the brakes are applied the reverse will pause until the brakes are no longer being used.**

**From all of us at California Sidecar.
Enjoy the ride!**