



California Side Car

Trike Owner's Manual

Daytona (Harley-Davidson)
Arrow (Indian)
2022

Thank you for purchasing a CSC Trike Conversion!

At CSC our goal is to create a special riding experience that will bring you many happy miles of stress and trouble-free touring and exploration.

By choosing a CSC trike you have purchased one of the most reliable and maintenance free trike kits on the market today. But rest assured that if you do have trouble, you are covered by the industries top warranty, and are also connected to the largest trike dealer/service network in the world.

Because our trike kits are built with the highest quality and latest technology components there is very little maintenance. This owner's manual will walk you through these details.

Sincerely,
CSC Trikes
www.californiasidecar.com

Table of Contents:

1. Riding a Trike pg.4
2. Trike Features pg.4
3. Trike Specs pg.7
4. Maintenance Schedule pg.8
5. Shock Spring Preload Adjustment pg.10
6. Trailering Your Trike pg.12
7. Trike Jacking Point pg.13
8. Replacement of Bulbs pg.14
9. Park Brake Adjustment pg.15

Riding a Trike:

Now that you have purchased a CSC trike, riding it will be different, but much easier than riding your two wheeled motorcycle. Worrying about gravel and leaves in the road or navigating parking lots will be a thing of the past. With this decrease in stress, you will soon discover that you are able to ride for much longer periods of time than before. So relax and enjoy the sights. Life on a trike is great, just remember to keep your feet up when you stop!

Trike Features:

Brakes

- If your Harley-Davidson or Indian motorcycle was equipped from the factory with ABS (Anti-Lock Brakes) your CSC trike will retain this feature.
- If your Harley-Davidson or Indian motorcycle was equipped with a linked (front and rear) braking system, this system will be retained on your trike.
- Brake pad wear is highly dependent on riding style, GVWR, and riding environment. Typical pad life will range from 20k miles to 30k miles.

Body

- If your Harley-Davidson or Indian motorcycle was equipped with a TPMS (Tire Pressure Monitoring System) it will be disabled. Unfortunately, this OEM feature is not able to be adapted to a trike.

- The travel trunk or top trunk on your trike has been moved approximately 1 inch rearward from its original location to give your passenger more room.
- Your trike has a battery powered trunk latch. If the battery is discharged the trunk can be accessed by pulling the emergency release cable that is located behind the left-hand side cover.
- Your trike has been painted with the highest quality automotive paints. These paints can take up to 90 days to fully cure. Do not wax or cover your trike body during this time. You can however pinstripe or have murals painted during this time.
- If your trike is equipped with Ground Effects (optional) you will notice that there is a cornering light in the front of each side. These will illuminate the ground in the direction you are turning when the turn signal is activated. See instructions for changing the bulb on pg. 14

Suspension

- Your trike may be equipped with a preload adjuster (optional). The preload adjuster is simply a way to raise and lower the height of the rear suspension on your trike. This is necessary to compensate for varying loads. By using this adjustment, the correct ride height of the trike can be maintained regardless of load. See instructions pg. 10 for how to set the preload adjuster.

- Because the optimal steering geometry for a two wheeled vehicle is significantly different than the optimal geometry for a three wheeled vehicle, your trike is most likely equipped with a CSC Powertrak (optional). This option includes new triple clamps for the front suspension that make the steering easier, more stable, and safer.

Drivetrain

- Your trike has been equipped with heavy duty drive belts to power the rear wheels. These require minimal maintenance and should last the lifetime of your trike.
- Your trike retains the same final gear ratio (numerically) as the stock motorcycle unless equipped with CSC “Performance Gear” (optional for Daytona only). This option helps add extra torque to compensate for the weight of the trike kit.

Towing

- CSC trikes are excellent tow vehicles. Your trike is already equipped with a trailer hitch mount and a 6-pin female trailer plug connector. All that is needed to tow a trailer is a draw bar, ball, and compatible male trailer plug. All are available from CSC.

Trike Specs:

GVWR: = Curb Weight + Max Payload

Curb Weight: 1330lb (545kg)

Max Payload Capacity (Shock Spring Dependent)

525lb (238kg) (optional)

650lb (295kg)

775lb (352kg) (optional)

Overall Width (with fender trim):

Arrow 60in (152.4cm)

Daytona 59in (149.9cm)

Overall Length (with Powertrak):

Arrow 112in (284.5cm)

Daytona 113.3in (287.8cm)

Trunk Capacity:

Arrow 6.2 cubic ft (175.6L)

Daytona 8 cubic ft (226.5L)

Ground Clearance: 4.75in (12cm)

Max trailer weight: 600lb (272kg)

Max trailer tongue weight: 50lb (23kg)

Rear tire size: 215/45-17 or 205/55-16

Rear tire air pressure: 25psi (17in) or 28psi (16in)

Rear wheel lug nut torque: 70ft-lb (95NM)

Trailer plug wire colors:

White = Ground

Brown = Running Light

Yellow = Left Turn

Green = Right Turn

Red = Brake

Black = Accessory (constant 12V)

Maintenance Schedule:

Items	Frequency Miles							Replace	
	Daily	500	4K	8K	12K	16K	20K		24K
Brake Pads and Rotors [1]			I	I	I	I	I	I	
CV Boots					I			I	
Drive Belts				I		I	T	I	
Wheel Bearings [2]			I	I	I	I	I	I	
Wheels and Tires			I	I	I	I	I	I	
Lighting	I								
Tire Pressure	I								
Brake Fluid			I	I	I	I	I	I	2 Years
Powertrak Head Bearings [3]				H		H		H	

At higher odometer readings, repeat at frequency intervals established here.

I: Inspect and clean, adjust, lubricate, and/or replace if necessary.

R: Replace

H: Check Torque of Head Bearings (top nut 80 ft.-lbs. adjuster nut 30 ft.-lbs.)

T: Check tension of drive belts and adjust if necessary. Check for wear on belt teeth.

This Schedule is in addition to the OEM Motorcycle Maintenance Schedule

NOTE:

[1] Minimum pad thickness is .04 inches (1.02mm)
Replace as required.

[2] Wheel bearing torque 200 ft-lb

[3] Head Bearing Torque 30 ft-lb

The service life of wear items such as brake pads and tires is dependent on many factors, including riding habits, road type, vehicle loading, environment etc.

Service & Maintenance questions – contact CSC Parts & Service at 434.263.6500

Shock Spring Preload Adjustment Instructions (if equipped):

The purpose of the Shock Spring Preload Adjuster (preloader) is to maintain the correct ride height of the rear suspension regardless of the amount of weight added to the trike. It does this by increasing or decreasing the force (preload) on the shock spring to raise or lower the rear suspension. As more preload is added the shock becomes longer and the suspension is raised.

Adding preload does not make the rear suspension stiffer, it only raises it.

The recommended height for the rear suspension when fully laden is 5-3/4in (146mm) +3/4in / - 1/4in from the ground to the lower suspension tray (see figure 1). Maintaining this height while riding will allow the trike to perform its best in regard to safety, handling and comfort.

Make the following adjustment when the trike is fully loaded with all weight added (including rider, passenger, and cargo, etc.)

To make this adjustment do the following.

1. Remove the left side cover.
2. Daytona 2014-Current: Insert the T-handle wrench into the upper right side panel grommet and into preloader screw.
Arrow: Insert the T-handle wrench into preloader screw visible through frame opening
3. Turn Clockwise to increase preload and raise the suspension
4. Turn Counterclockwise to decrease preload and lower the suspension.
5. Double check measurement after cycling (bouncing) the rear suspension a couple of times.

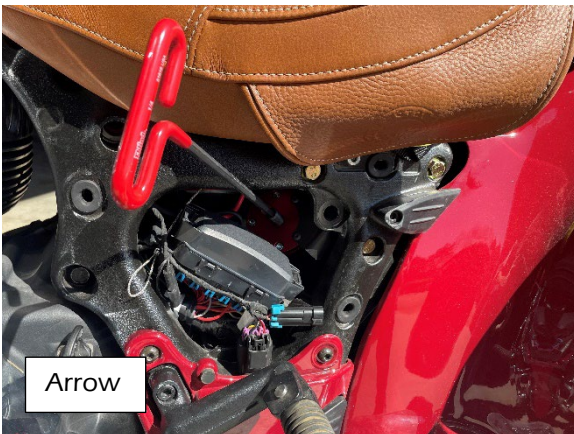
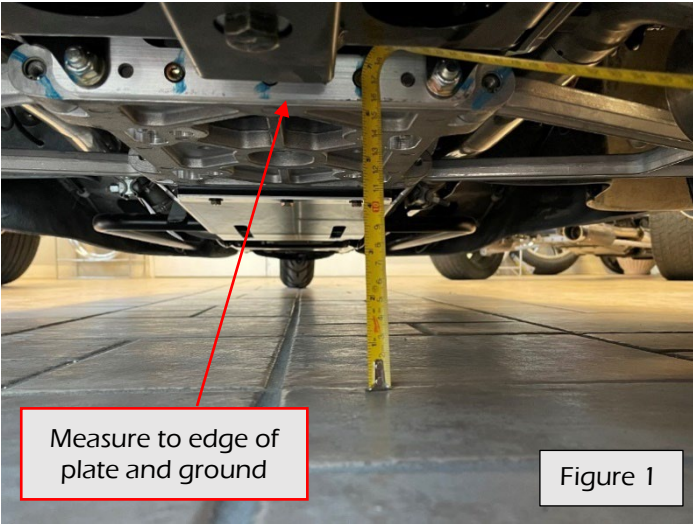

Trailing your CSC trike:

If you plan on trailing your trike, please use this diagram for the proper tie down procedure. Failure to do so may over time result in damage to the trike shock and/or suspension components.

When strapping down the rear of your trike please hook your tie downs on the inside of your lower control arms, then cross them for more security. In the front choose a strong attachment point such as the lower frame tube, engine guard, or lower triple clamp.

Securing your trike in this manner will compress the suspension so it does not bounce around with the trailer. This will greatly limit the movement of your trikes suspension when it is in tow.

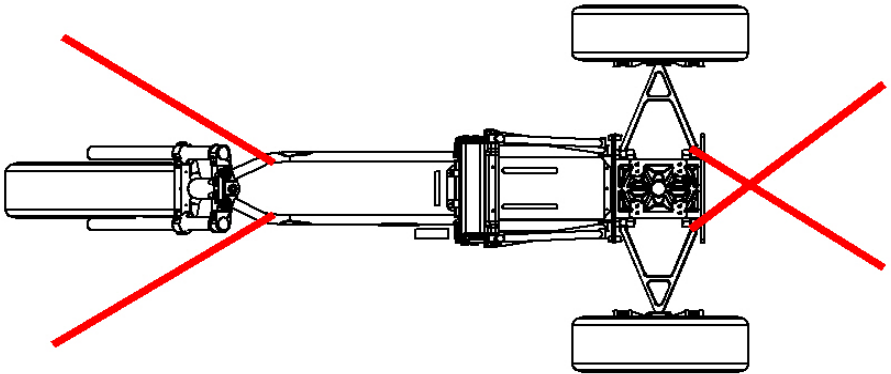

Trike Jacking Point:

The jacking point on a CSC trike is shown below in the diagram. Jacking point is in the center. NOT on the side.

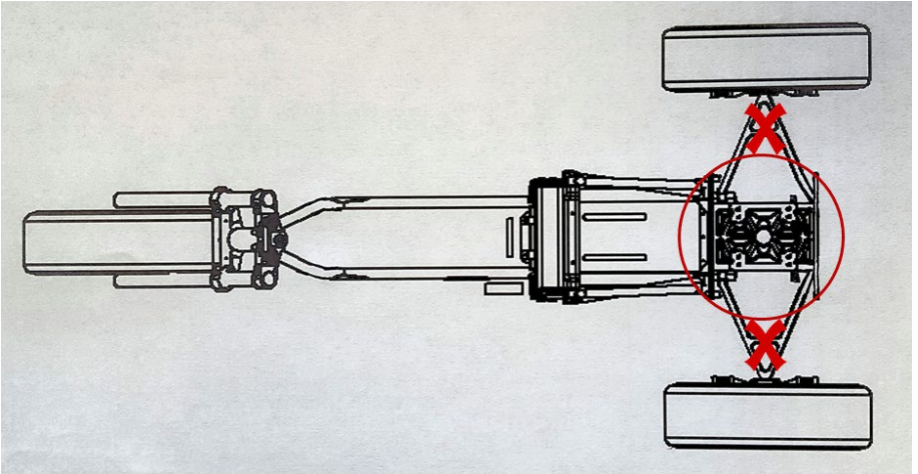

Replacement of Ground Effects bulbs:

1. Locate rubber socket cover over backside of ground effects bulb housing. Remove by pulling it off.
2. Locate the #2 Philips head screws in the center of the housing and remove screw. Remove with black ground wire.
3. Remove bulb, cut white wire.
4. Using a wire connector, connect the white wire to the new bulb.
5. Reinstall in reverse order and test.

Park Brake Adjustment: SINGLE or DUAL Caliper

1. With brake handle down, adjust caliper lever on both sides, with square head bolt so brake pads barely free-float on the brake rotor. Secure with lock nut.
2. Test brake calipers and handle to ensure proper function. The calipers should lock the rotor after 3 to 5 clicks of the handle. Re-adjust as necessary.

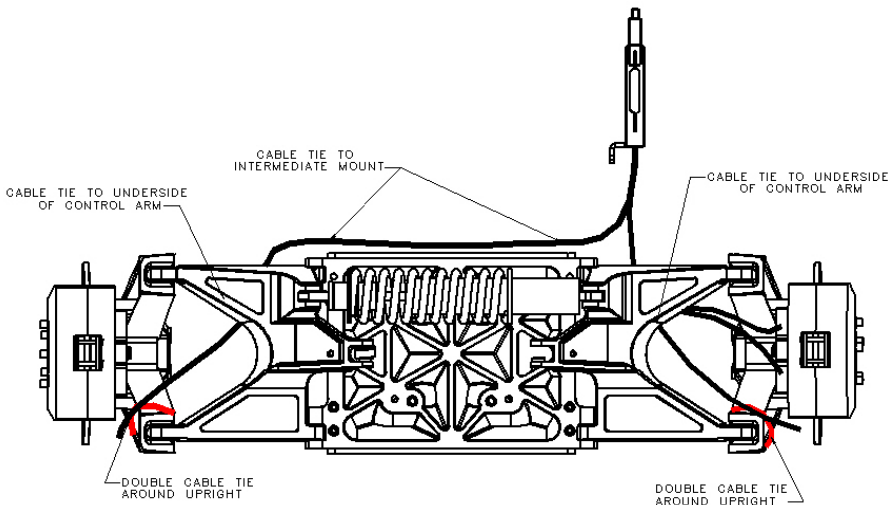

TRIKE WARRANTY

5 YEARS / UNLIMITED MILES

California Sidecar warrants to the original and subsequent owners that all component parts of this Trike Conversion Kit are free from defects in materials and workmanship, subject to the following terms and conditions:

WARRANTY PERIOD:

5 YEARS / UNLIMITED MILES. Warranty repairs will be made at no charge for parts and labor provided that the conversion kit was installed by a "factory authorized stocking dealer". If installed by other than an "authorized dealer" the warranty covers parts only, and only if the kit was properly installed in accordance with manufacturers' instructions. All warranty repairs must be pre-approved by the manufacturers' Service Department and according to prescribed procedures.

Proof of purchase must accompany all warranty claims. All defective parts must be returned prepaid prior to shipment of replacement part.

ITEMS NOT COVERED:

Damage caused in any part by misuse, lack of maintenance, improper alterations and repairs required by normal vehicle maintenance. These items include, but are not limited to, brake and clutch linings, chains, sprockets, belts, pulleys, gears, gaskets, bearings, lights, and suspension boots.

Defects in the fiberglass, paint, chrome trim, light bulbs, LED or other appearance parts are covered for a period of six (6) months provided that the damage is not caused by road hazards or the environment (i.e. tree sap, rock chips, road salt, etc.) Repairs to the host motorcycle are not covered.

Should it become necessary to return the product, either in whole or in part, to the manufacturer's facility, the buyer / owner of the product will be responsible for pre-paid shipping costs. The manufacturer will also pay one-way shipping costs.

Loss of time and use, and other incidental or consequential damages are not covered.

EXCLUSIONS:

Any vehicle which is used commercially, raced or used in any way, other than its intended use, shall not be covered by this warranty. Any vehicle which is not timely registered with the manufacturer or any vehicle with an altered odometer.

This limited warranty applies as stated except in those states that have specific statutes to the contrary. In those states, state law is applicable.

100 Motorcycle Run • Arrington, VA 22922
www.californiasidecar.com

CSC VIN/Order # _____

From all of us at
California
Sidecar...Enjoy the
Ride!

Updated
4/18/2022