

Arrow

By **CSC**
TRIKES

Trike Conversion Kit for

INDIAN MOTORCYCLES

**CLASSIC - VINTAGE - DARKHORSE
CHIEFTAN & ROADMASTER MODELS
2014 - CURRENT**

Installation Instructions

Revised 4 - 2021

**California Sidecar Parts & Technical Support
434.263.8866**

Table of Contents:

1. Warnings and Considerations	4
2. Maintenance Schedule	5
3. Disassembly of Motorcycle	6
4. Models with Tour Box	7
5. Component Installation	15
6. Brake Line Installation	16
7. Rear Suspension Unit Installation	17
8. Gravel Pan	18
9. Brake Bleeding Procedure	20
10. Abs Wheel Speed Sensor	21
11. Muffler and Tailpipe Installation	22
12. Link to CSC Belt Tensioning video	24
13. Setting up the Sonic Tension Meter	24
14. Using the Sonic Tension Meter	24
15. Tensioning the Front Drive Belt	25
16. Tensioning the Rear Drive Belt	26
17. Shock Spring Preloader Installation	28
18. Suspension Setup	29
19. Trike Body Installation	31
20. Trike Body Alignment	33
21. Securing the Trike Body	34
22. Tour Box Installation	35
23. Final Assembly	39

Warnings and considerations:

Disclaimer - These instructions assume a level of understanding of motorcycle repair and maintenance beyond that of a “beginner” and/or “novice” and California Sidecar cannot be liable for an installer’s failure to understand or follow these instructions as written. Likewise, California Sidecar cannot be responsible if any of the steps are omitted or shortcuts are taken, or parts other than those supplied by California Sidecar, are used in installing this trike kit.

1. **“WARNINGS”** are all printed in bold type and capitalized. They mean to use **extreme care** in a given step so as not to damage the part, motorcycle, and/or yourself.
2. Always wear safety glasses when using hand and/or power tools.
3. When working in and around the fuel system, always work in a well-ventilated area, free from sparks and open flames.
4. All directional references to the “right side” and the “left side” are as you were seated on the motorcycle.
5. All directional references to “forward” mean to the front of the motorcycle while “back” means the rear of the motorcycle unless otherwise stated.

Recommended Lubricants:

1. Thread locking compound (Loctite 242 minimum).
2. High temperature Silicone sealant.

Maintenance Schedule: **ARROW**

Frequency (miles)	Daily	4k	8k	12k	16k	20k	24k
Item	/	/	/	/	/	/	/
Belts	I	I	I	I	I	T	I
Brake Pads and Rotors [1]		I	I	I	I	I	I
Half Shaft Boots		L	L	L	L	L	L
Wheel Bearings [2]		I	I	I	I	I	I
Wheels and Tires		I	I	I	I	I	I
All Lighting	I						
Tire Pressure [3]	I						
Brake fluid		I	I	R	I	I	R

I: Inspect: clean, lubricate, and/or replace as necessary.

R: Replace

L: Lubricate with Silicone Spray

T: Tension

NOTE:

[1] Minimum pad thickness is 0.04 inches (1.02mm)

[2] Wheel bearing axle torque 200 FT.-LBS.

[3] Rear tire pressure **15" & 16" WHEELS 28 PSI**
17" WHEELS 25 PSI

At higher odometer readings, repeat at frequency intervals established here.

This Schedule **is in addition to** the INDIAN Maintenance Schedule

NOTICE:

The remote door opener installed on this unit has a very small electrical draw on your motorcycle battery. **If your trike will be idle for more than 2 weeks** you should **remove** the 15 amp fuse from the red fuse holder located under your seat or right side cover. Another option is using a battery tender.

Service & Maintenance questions – contact Parts & Service at
434.263.8866

Disassembly of Motorcycle



1. Remove & Save the Top Side Covers
2. Remove & Discard Saddle Bags (if equipped)
3. Remove & Save the Seat (3 fasteners)
4. Disconnect the Negative Battery Cable



Models with Tour Box

5. Remove & Save the Tour Box (10 Fasteners on the floor, two at the rear ((Chrome Bar)) and one wire plug)
6. Remove & Save the Chrome Bar (4 Fasteners)



7. Remove the Quick Disconnect Bracket
- 2015-2016 Models only:**
8. Remove & Save the Radio Amp and harness

All Models

9. Remove & Save the Exhaust Heat Shields
10. Remove & Save the Passenger Pegs or Floorboards
11. Remove & Save the Bottom Side Covers
12. Remove & Discard the Rear Highway bars (if equipped)
13. Remove & Save the 4 small triangle shaped black plastic frame covers & fasteners (if equipped)



14. Remove & Discard the Side stand
15. Remove & Discard the Antenna and its mount
16. Remove & Discard the Mufflers, Saving the Clamps



Remove & Discard Rear Fender

17. Unplug Fender wiring plug
18. Remove & Discard the 4 Saddlebag mounting Cylinders
19. Remove Chrome Frame Covers (2 fasteners each)
20. Loosen 4 fasteners inside the rear of fender
21. Remove 2 fasteners in front & 1 on top, on each side
22. Remove Fender
23. Save the two Grommet fasteners on the RT side
24. Remove & Discard the Passenger seat strap(if equipped)
25. Remove & Save the Tip Over Sensor & it's hardware
26. Remove & Discard the plastic inner fender



- 27. Remove the rear caliper (2 fasteners)**
- 28. Remove & Save the rear Wheel Speed Sensor (1 fastener & shim)**
- 29. Remove & Save the Front Sprocket Cover (4 fasteners)**
- 30. Remove & Discard the Rear Shock pivot shaft**
(Remove snap ring, now thread in a M5 bolt and use it to pull out the shaft)

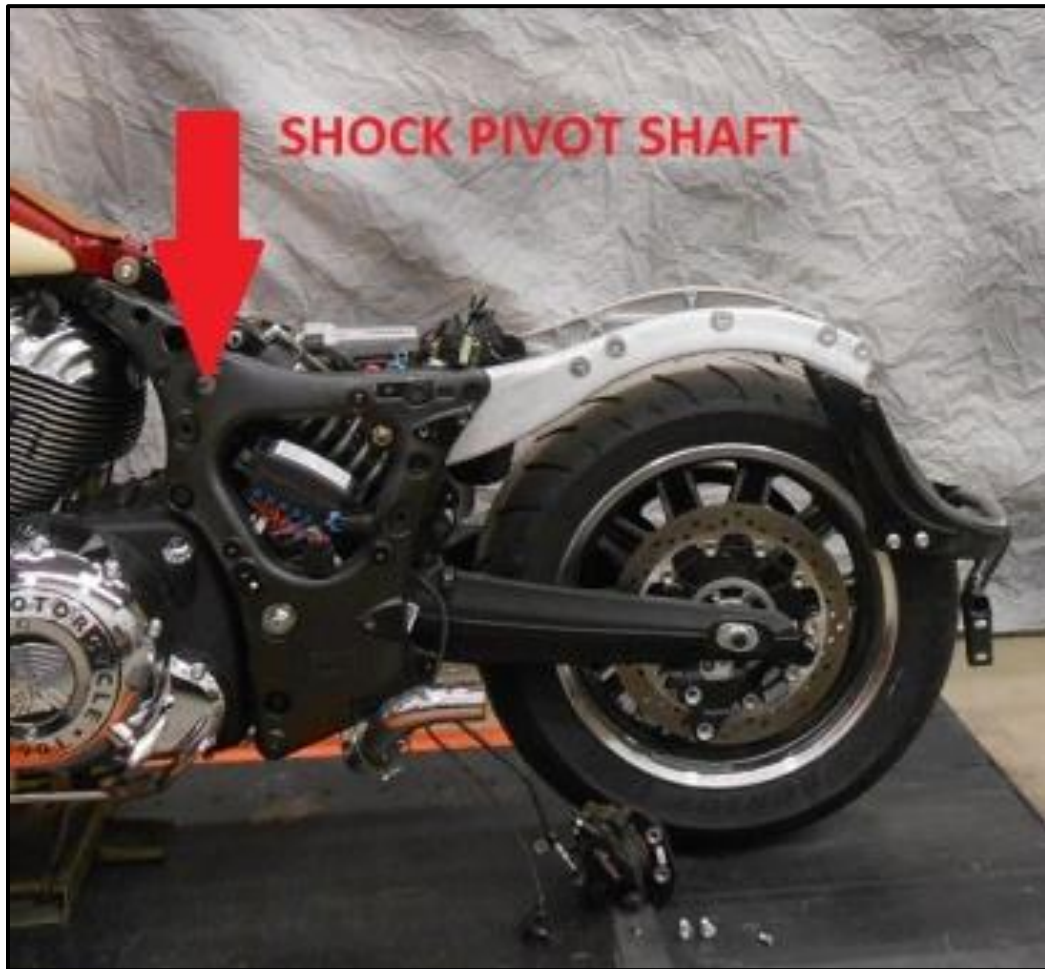

- 31. Remove the nut on the Rear Shock air line**
- 32. Remove & Save the Swing Arm Pivot Shaft**
Remove the left side Nyloc nut, then the Right side Jam Nut & last unthread the Pivot Shaft
- 33. Remove Drive Belt from front sprocket**

Remove Subframe & Swing Arm

34. Remove and Save the 3 fasteners on the rear of the Battery Box

35. Loosen 5 fasteners on the left side of frame shown in **RED 1 – 5**

36. Remove 6 fasteners on the rear Subframe shown in **BLUE 1 – 3 on both sides**
Saving 4 fasteners



37. Spread the frame apart and remove rear Subframe



38. Remove and discard Swing Arm, wheel, shock & belt as an assembly

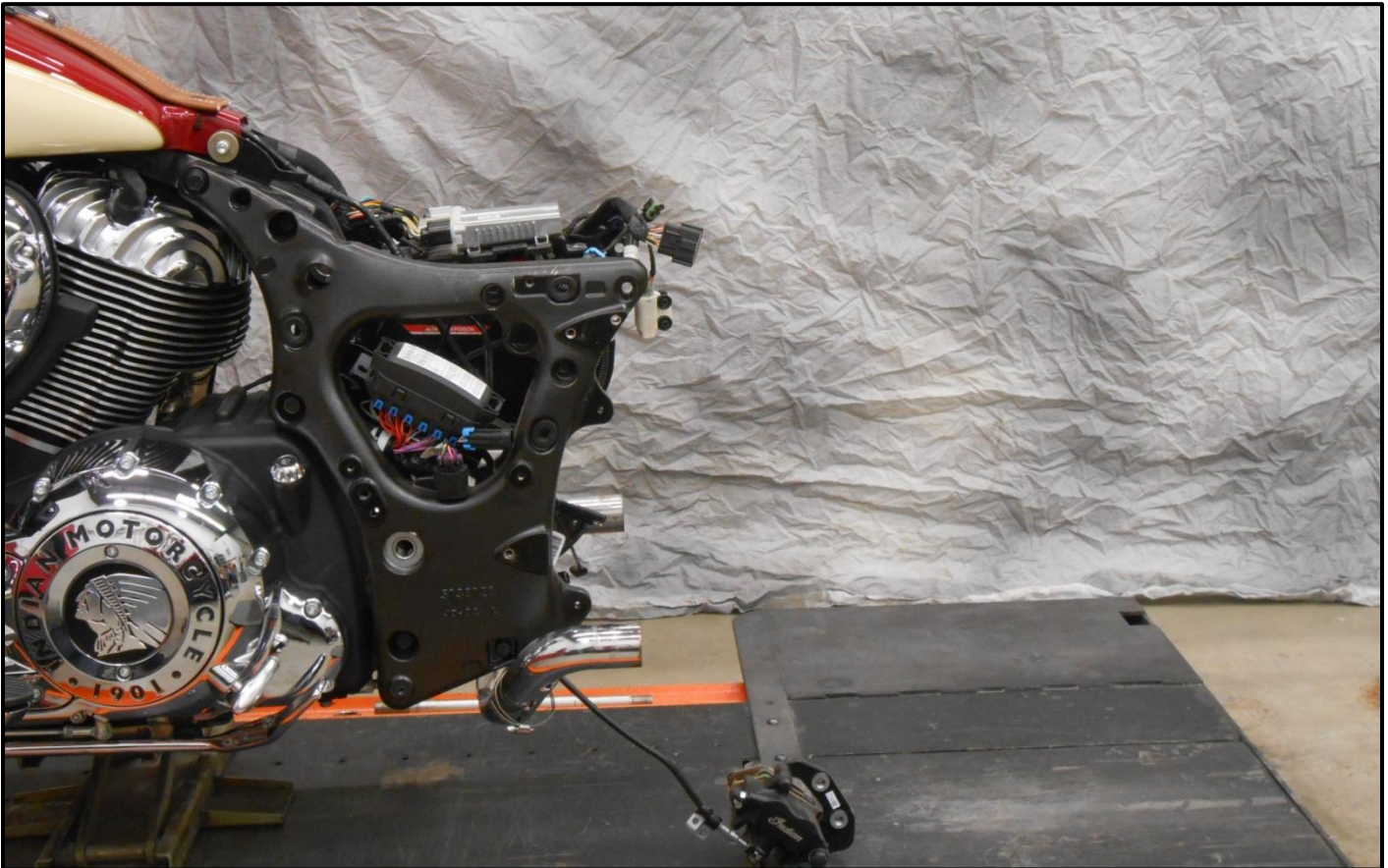

2017 and Newer Models Only: Voltage Regulator Installation: CSC Trick: Remove left side of Motorcycle frame for steps 1-10

- 1. Locate the motorcycle Engine Control Module under the battery box.**
- 2. The two PURPLE with PINK tracer wires from the motorcycle ECM will need to be uncovered from the motorcycle harness. See picture.**
- 3. Cut these wires approximately 2 inches away from the ECM connector.**
- 4. Connect, solder and heat shrink tube the PURPLE wire from the CSC pigtail to the 2 PURPLE w PINK TRACER wires coming from the motorcycle ECM connector.**

5. Connect, solder and heat shrink tube the RED wire from the CSC pigtail to the 2 PURPLE w PINK TRACER wires coming from the motorcycle wire harness.
6. Connect the BLACK wire from the CSC pigtail to a good chassis ground. Where the motorcycle negative battery cable connects is the recommended spot.
7. Plug the regulator module into the CSC pigtail.
8. Secure the module to the back of the fuse box.
9. Tape up the OEM harness.
10. There is also a Jumper plug supplied, ziptie it to the connector of the module in case the module fails.
11. Loosely reinstall the Motorcycle frame left side.

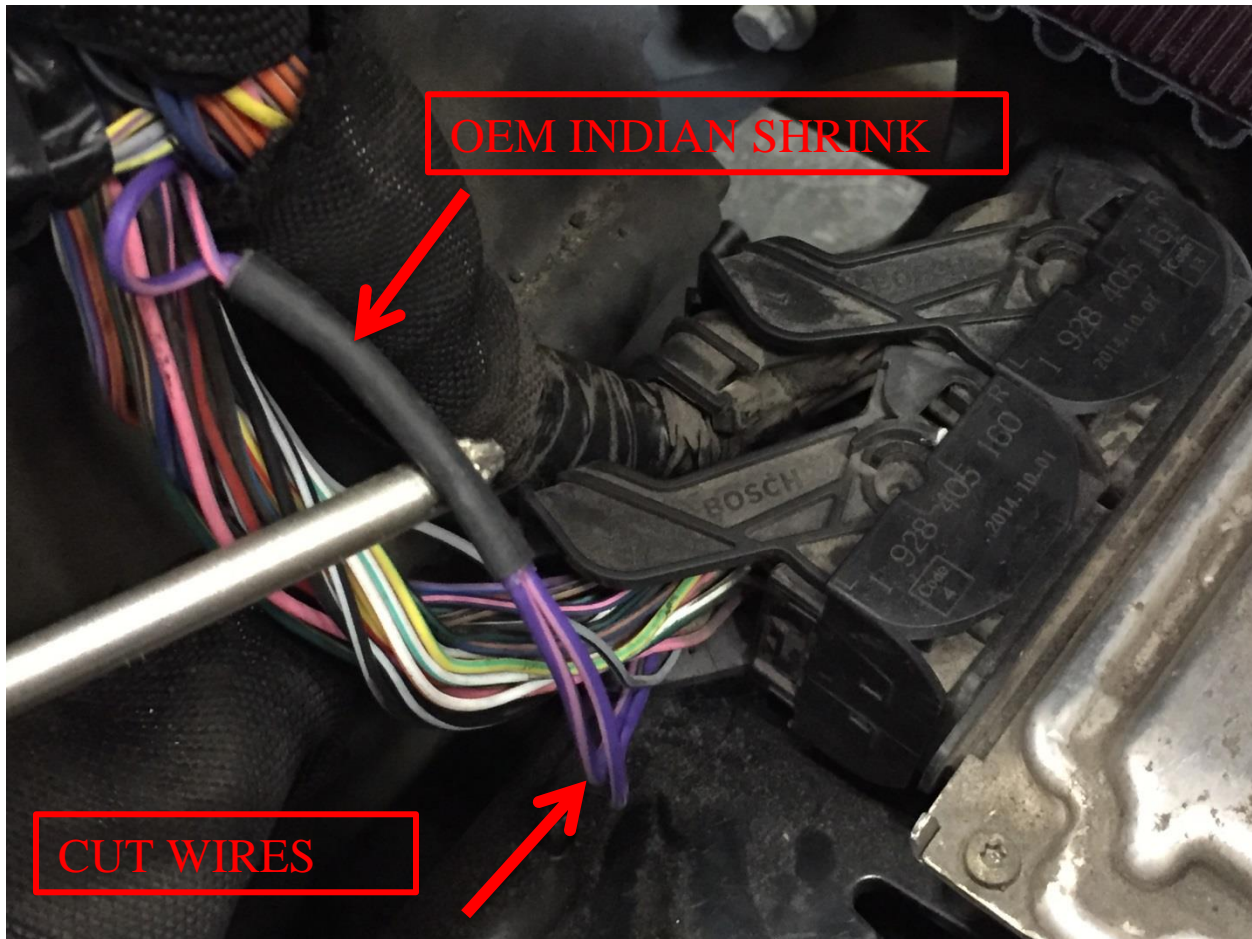

Component Installation

1. Install **NEW CSC** Belt on Front Sprocket
2. Reinstall the Front Sprocket Cover
3. Lightly tap 2 Hollow Dowels into the upper rear holes of the Upper Cross Brace
4. Install Upper Cross Brace
5. Reinstall 4 OEM fasteners in the upper front and lower rear holes with flat washers and nyloc nuts leave loose
6. Lightly tap the Hollow Dowels into the Motorcycle frame
7. Install 2 M10x70 HHCS with flat washers in the upper rear holes as shown
8. Install the 3 OEM fasteners in the battery box and its cover
9. Reinstall the Grommet fasteners on the right side using an OEM washer & a new washer

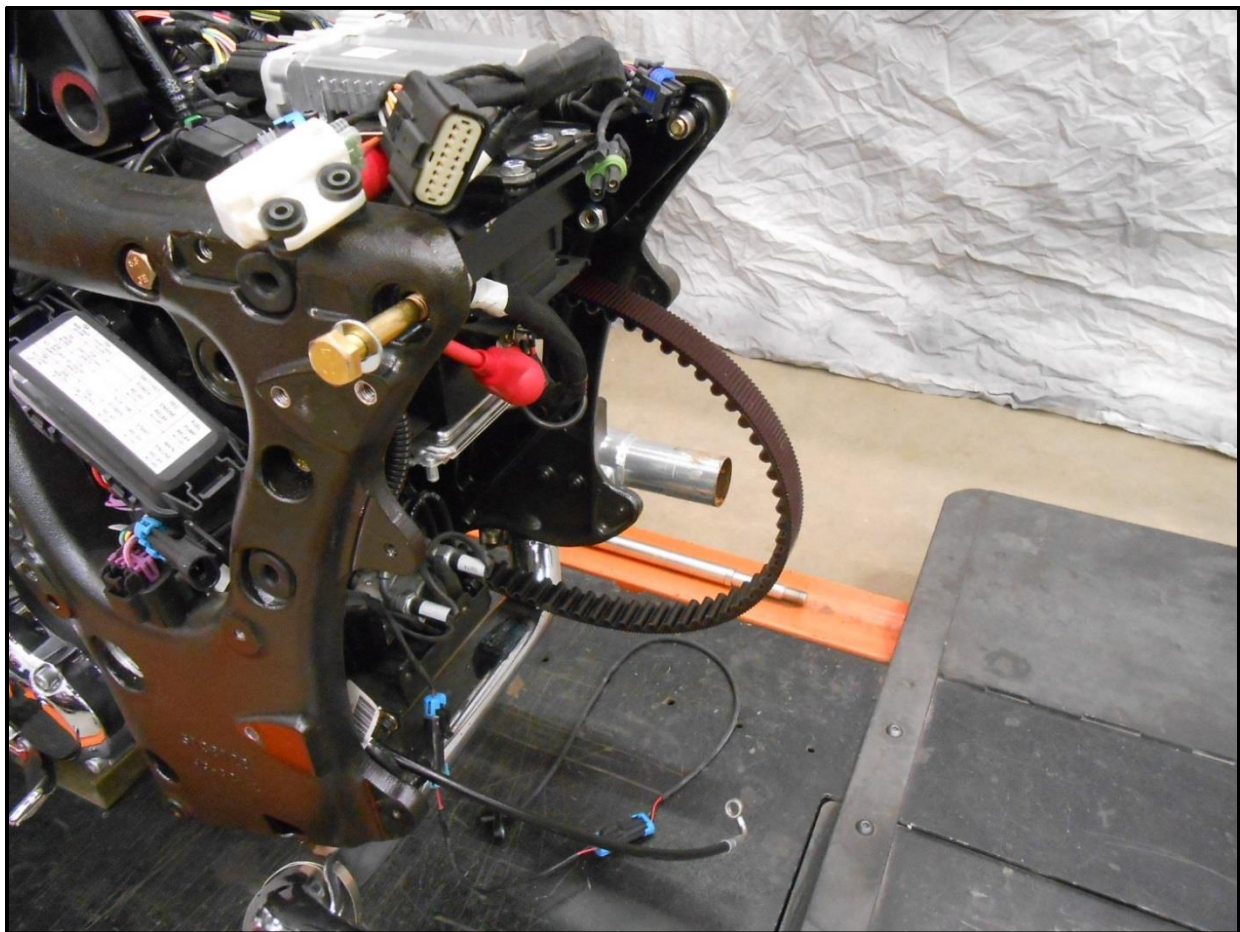

Brake Line Installation

1. Remove & Discard OEM Brake line and caliper
2. Install new CSC Brake line reusing **OEM** Banjo Bolt though the straight fitting with 2 new crush washers
3. Plug in the Wheel Speed Sensor Extension then the OEM Wheel Speed Sensor
4. Leave both the brake line and sensor wire so they go under the Drive Support

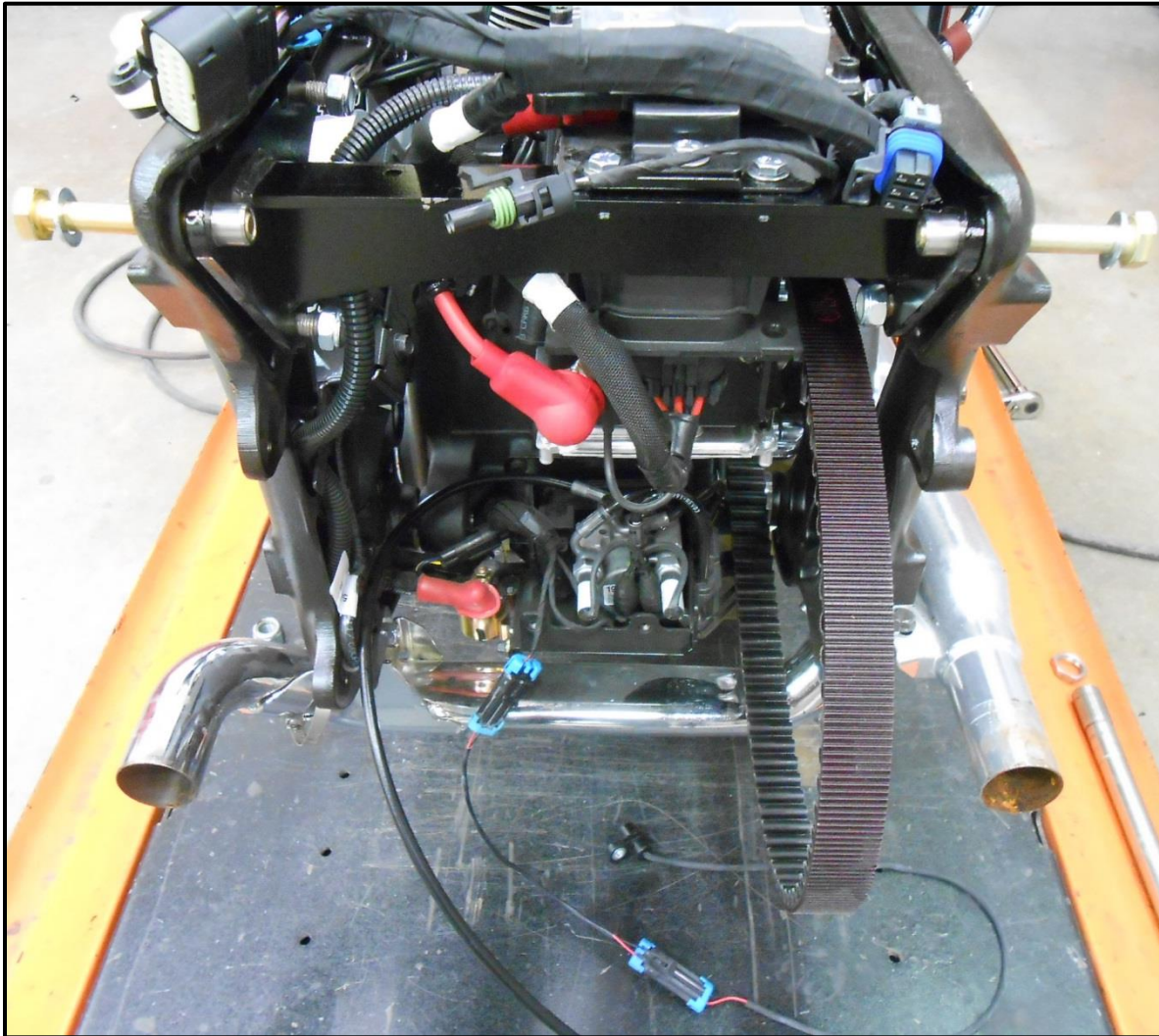

Rear Suspension Unit Installation

1. Position Trike Suspension Unit behind prepared motorcycle frame
2. Install CSC Belt on Drive Sprocket
3. Reinstall the Tip Over Sensor with OEM hardware
4. Install the stud plate up through the Cross Frame Brace, Tip Over Sensor on top and secure with nut and washer
5. Make sure the “UP” is up on the Tip Over Sensor

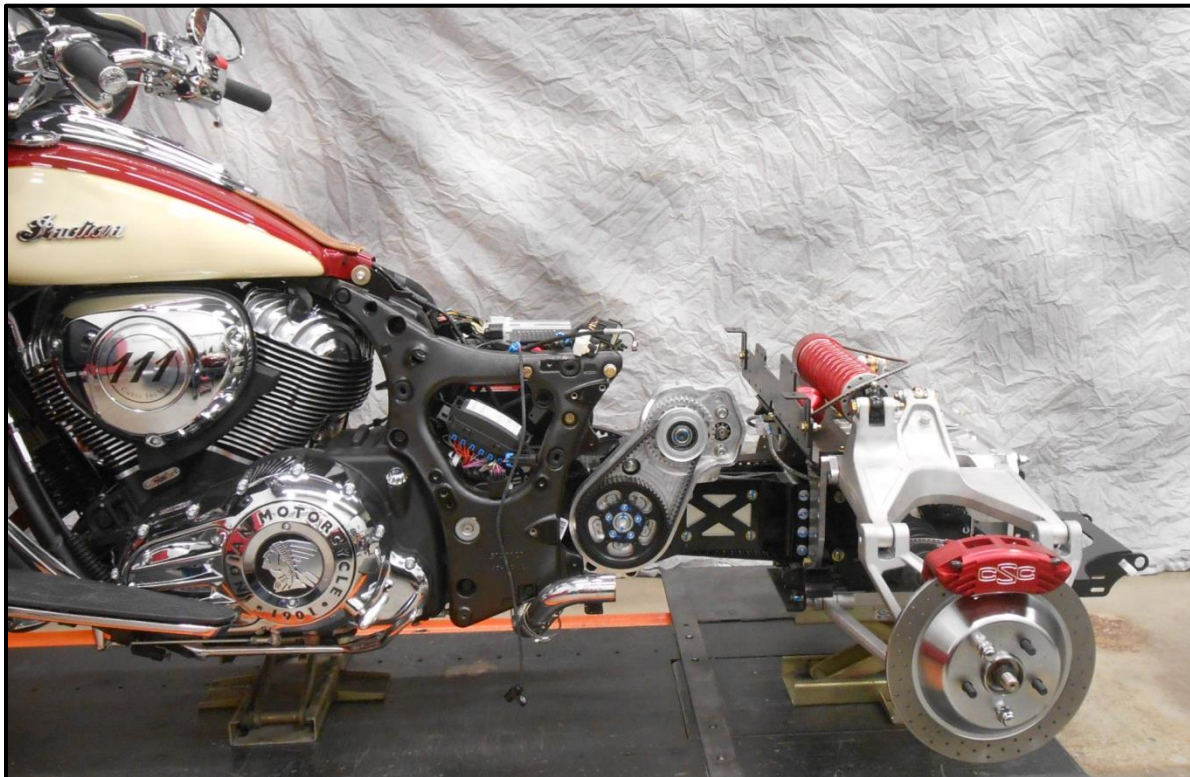

6. Install Swing Arm Pivot Shaft & thread it in until you have approx. 1 inch of threads still sticking out on the right side

7. Loosely install the Frame Mounts over the Dowels on the Upper Cross Brace

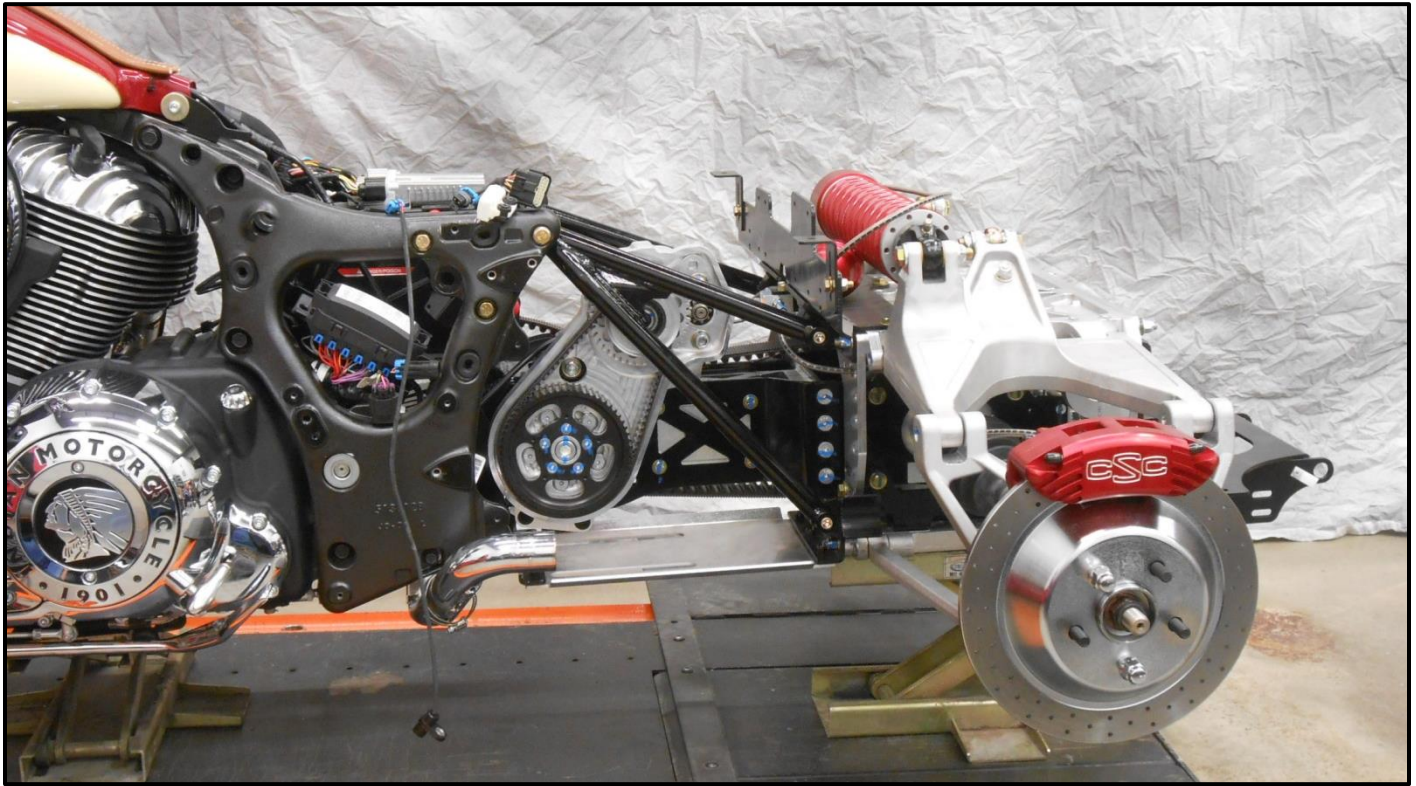

- 8. Push Suspension forward to align with Frame Mounts**
- 9. Loosely install 4 3/8 SHCS in the rear of both Frame Mounts**
- 10. Install the Gravel Pan with 5 1/4 HHCS and flat washers from the bottom up securing with nyloc nuts (it may be necessary to pull on Suspension to align Gravel Pan)**
- 11. Install nyloc nuts & flat washers on the 2 M10 & 4 3/8 fasteners on the Frame Mounts**
- 12. Route the CSC Brake Line up the left side of the Drive Support then on top of the belt but under the Reverse motor, then 90 up to the Distribution block with a new Banjo bolt and 2 new crush washers**
- 13. Secure the Brake Line to the Drive support, there is a small hole in the side, route a ziptie in the hole then up through the triangle hole on top. Now secure it to the top of the Drive Support where the pivot shaft goes.**

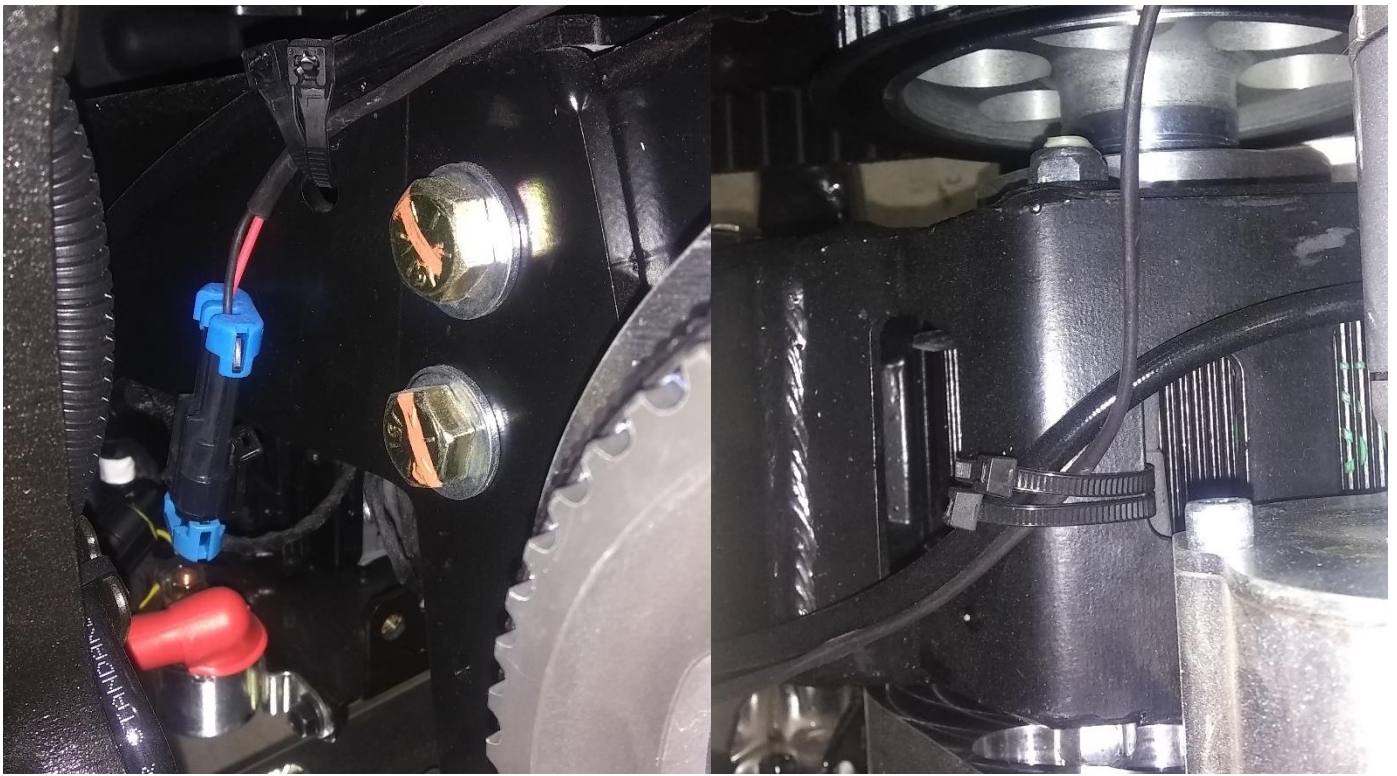

14. Tighten Fasteners in this order

- a. OEM motorcycle frame (5)
- b. Upper Cross Brace (6)
- c. Rear Frame Mount (4)
- d. Gravel Pan (5)
- e. OEM Pivot Shaft

Tighten until it bottoms out then back it off 1 full turn, tighten the right side Jam Nut, and last tighten the left side Nyloc Nut.

After Tightening:

**There should be approx. 3 threads out on the right side
1- 2 threads out on the left side**

Brake Bleeding Procedure

- 1. Using recommended brake fluid, fill Rear Brake Master Cylinder Reservoir**
- 2. Using a vacuum bleeder, follow this procedure carefully**
- 3. Rear caliper rear bleed valves outsides first then insides on each side**
- 4. Rear caliper front bleed valves outsides first then inside on each side**
- 5. Hand bleed the system using the above sequence until all air is removed from the lines**
- 6. Allow the bike to set for a minimum of 20 minutes and recheck the pedal travel**
- 7. If there is excessive pedal travel on the first pump, repeat steps 3 and 4**
- 8. When complete reinstall the bleeder caps**



ABS Wheel Speed Sensor Installation

1. Install the OEM ABS Wheel Speed Sensor with OEM SHCS and shims if needed (air gap .080 +/- .005)

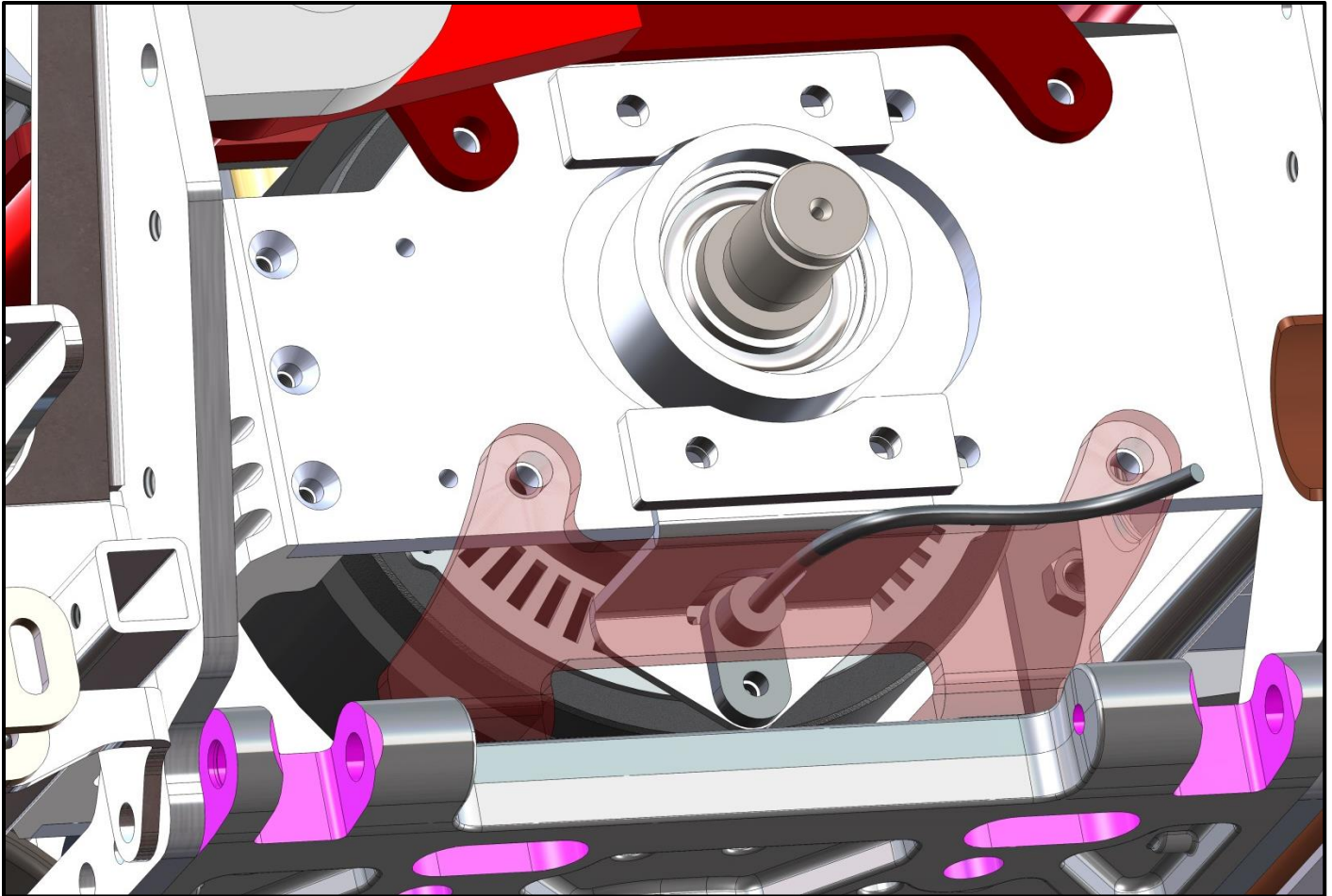

2014-2017 Install the provided Extension wire.

2018-UP ABS SIGNAL CONDITIONER:

1. Plug in the CSC module between the ABS sensor and the motorcycle ABS system.
2. Secure the CSC module to the intermediate mount.
3. Once the trike body is installed plug in the 4 pin T harness to the GFX plug on the trike body harness.
4. Secure the sensor wires and the CSC module wires with zip ties.

Muffler and Tailpipe Installation

1. Install Muffler Mount using three 5/16-18X1 1/4 HHCS, 6 flat washers and 3 nyloc nuts in the lower set of holes
2. If installing the Trailer Hitch Option, install it now

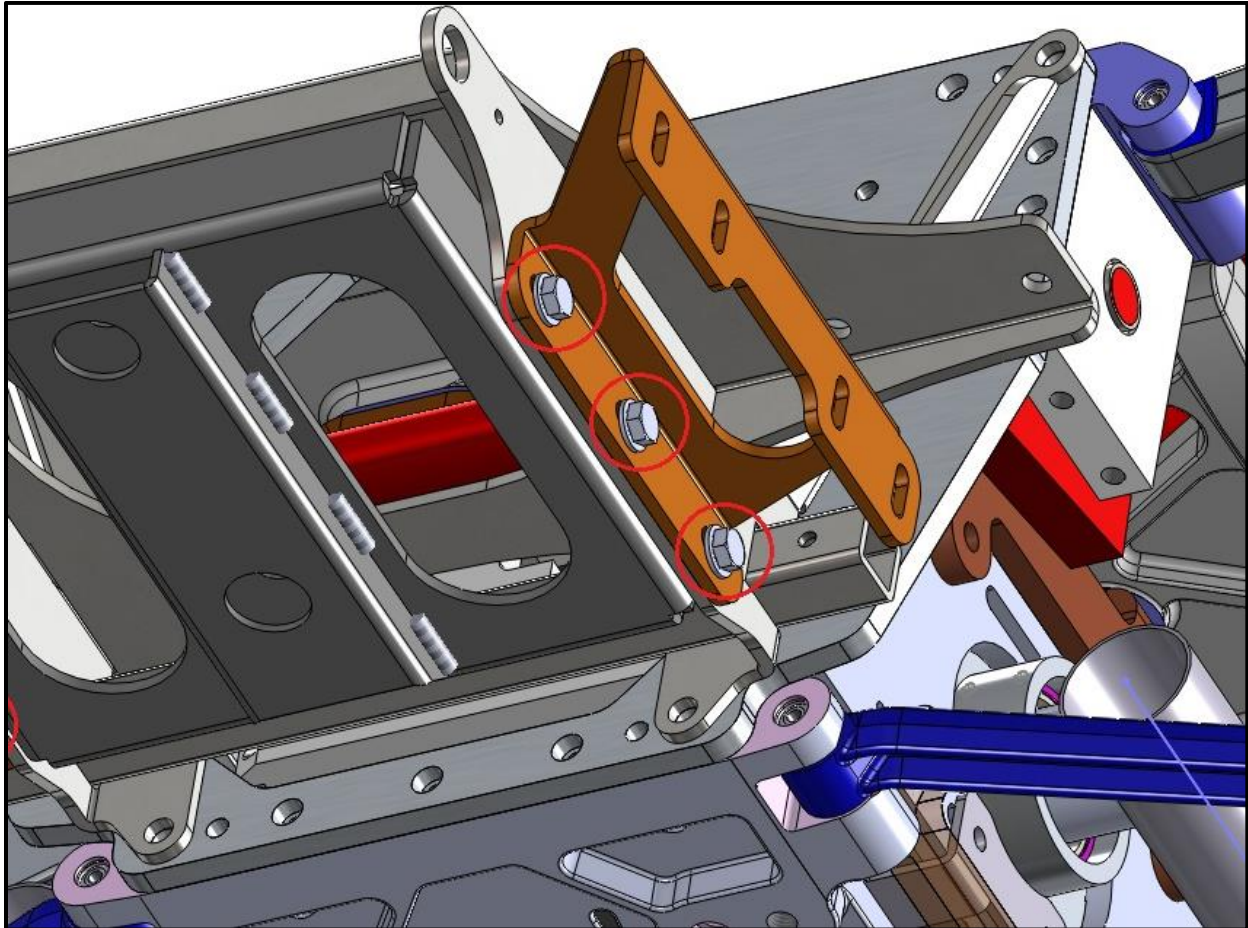

3. Install CSC Tailpipes onto the rear of the OEM head pipes, Reusing the OEM clamps and a new clamp on the lower front mount saddle
4. Install the CSC Muffler onto the tailpipe securing it to the muffler mount with two 5/16-18X3/4 HHCS and flat washers, and to the tailpipe with a clamp
5. Tighten clamps but leave the 2 HHCS securing the mufflers loose to be tightened after the body is installed

**Install the Electric Reverse now if equipped
Refer to separate instructions**

**Install the GRD EFX Mounts now if equipped
Refer to separate instructions**

Link to CSC Belt Tensioning video

<http://www.californiasidecar.com/support.html>

Setting up the Sonic Tension Meter

1. Turn power on, Push Select then 1
2. Using the charts below in Front and Rear belt tensioning push Mass, then the numbers, Width and so on
3. For the Rear belt, push Select then 2. Reverse belt can be number 3 and so on

Using the Sonic Tension Meter

1. Using the Sonic Tension Meter
2. The microphone placement over the belt is critical
 - a. The microphone should be in the middle of the belt width-wise
 - b. The microphone should be equally in-between the two Sprockets
 - c. The microphone should be between $\frac{1}{4}$ and $\frac{1}{2}$ an inch above or below the Belt
3. Ensure that the correct setting is displayed on the LCD screen
4. Push MEASURE, then gently tap the Belt with a wrench while holding the microphone in the correct position. A measurement in Lbs. of single span tension should display. If not, continue tightening the Belt until a reading is displayed
5. In noisy environments the Sonic Tension Meter may display errant numbers. If so, use in a quieter area
6. Always take at least THREE readings of the Belt tension and average the THREE readings to determine the actual tension of the Belt

Tensioning the Front Drive Belt

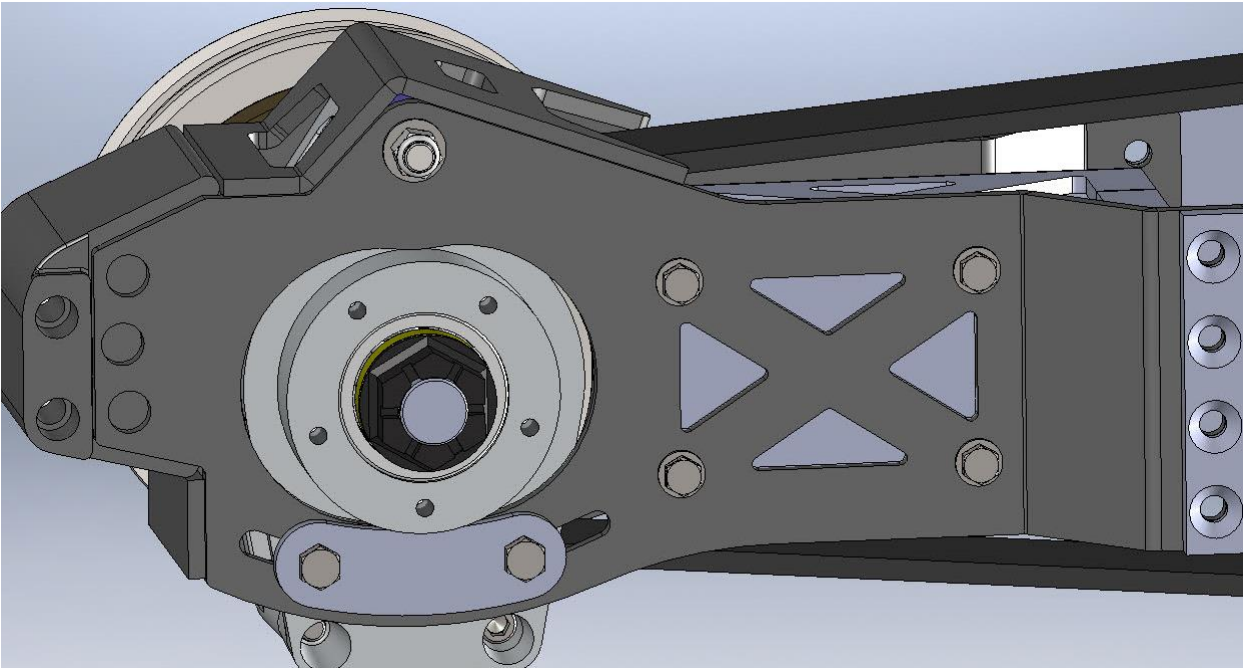

1. With the four HHCS in the rear only on the right side loose. Loosen the four clamping HHCS two per side.
 2. Tighten the Rear Drive Belt adjuster nuts until the slack is taken up on the Front Drive Belt.
 3. Use the correct setting on the Sonic Tension Meter.
MASS 007.9g/m
WIDTH 028.0 mm/R
SPAN 0434 mm
 4. Check Front Drive Belt tension.
28mm Belt: 130 – 150 lbs. of single span tension.
 5. Once the correct belt tension is achieved tighten all fasteners loosened or left loose in step 1, Eight HHCS and check the upper pivot shaft nyloc nut.
 6. Verify belt tension.
- NOTE:** Belt tension may increase once all bolts are tightened.

Tensioning the Rear Drive Belt

1. See diagram below.

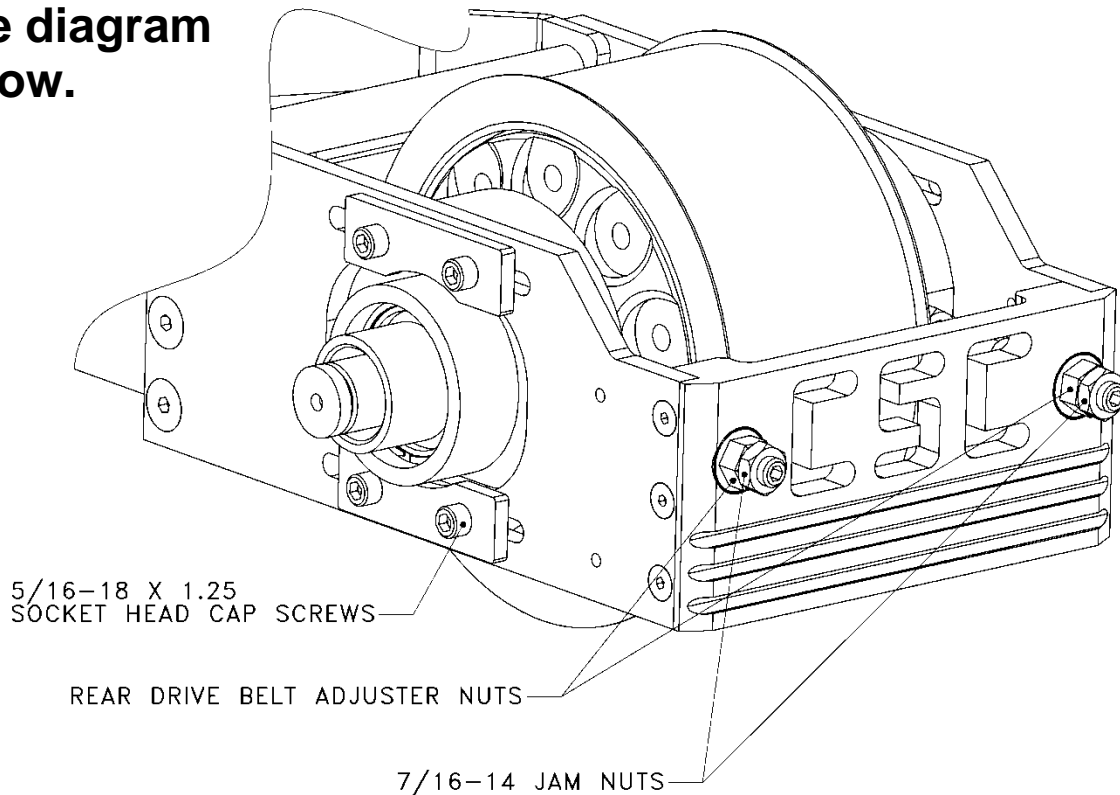

2. Tighten the Rear Drive Belt Adjuster nuts until the slack is taken up on the Rear Drive Belt.
3. Use the correct setting on the Sonic Tension Meter.
MASS 007.9 g/m
WIDTH 050.0 mm/R
SPAN 0442 mm
4. Check Rear Drive Belt tension.
50mm belt: 130 – 150 lbs. of single span tension.
5. In the next step you are going to run the engine. Please be aware of the safety of all those involved. Make sure you have at least two lug nuts on each brake rotor and that they are tight.
6. To finish alignment, the belt must have visual clearance between edge of belt and fence on front Rear Drive Sprocket. Check this by starting the engine and placing it in second gear and simply let the engine idle. Checking the alignment by eye and centering the belt as it spins. If belt

- has correct clearance, go to step 8. If it does not have clearance, proceed to step 7.
7. Use the Left and Right Rear Drive Belt Adjuster Nuts to align belt in order to achieve the necessary belt clearance. **NOTE: The belt will always track to the side of the sprocket that is the loosest. Repeat step 4.**
 8. Once the correct belt alignment and single span tension is achieved, tighten the eight 5/16 – 18 x 1 ¼ SHCS that go into the Carrier Bearing Support Housings.
 9. Install two 7/16 – 14 hex jam nuts onto the Rear Drive Belt Tensioning Studs and tighten.
 10. Verify belt tension and alignment.
 11. If the tension is correct move on to next step. If not, loosen clamping bolts and return to step 4.

Shock Spring Preloader Installation

1. Raise the Preload adjuster into the bracket as shown and secure with 2 10-32 X 1 BHSCS

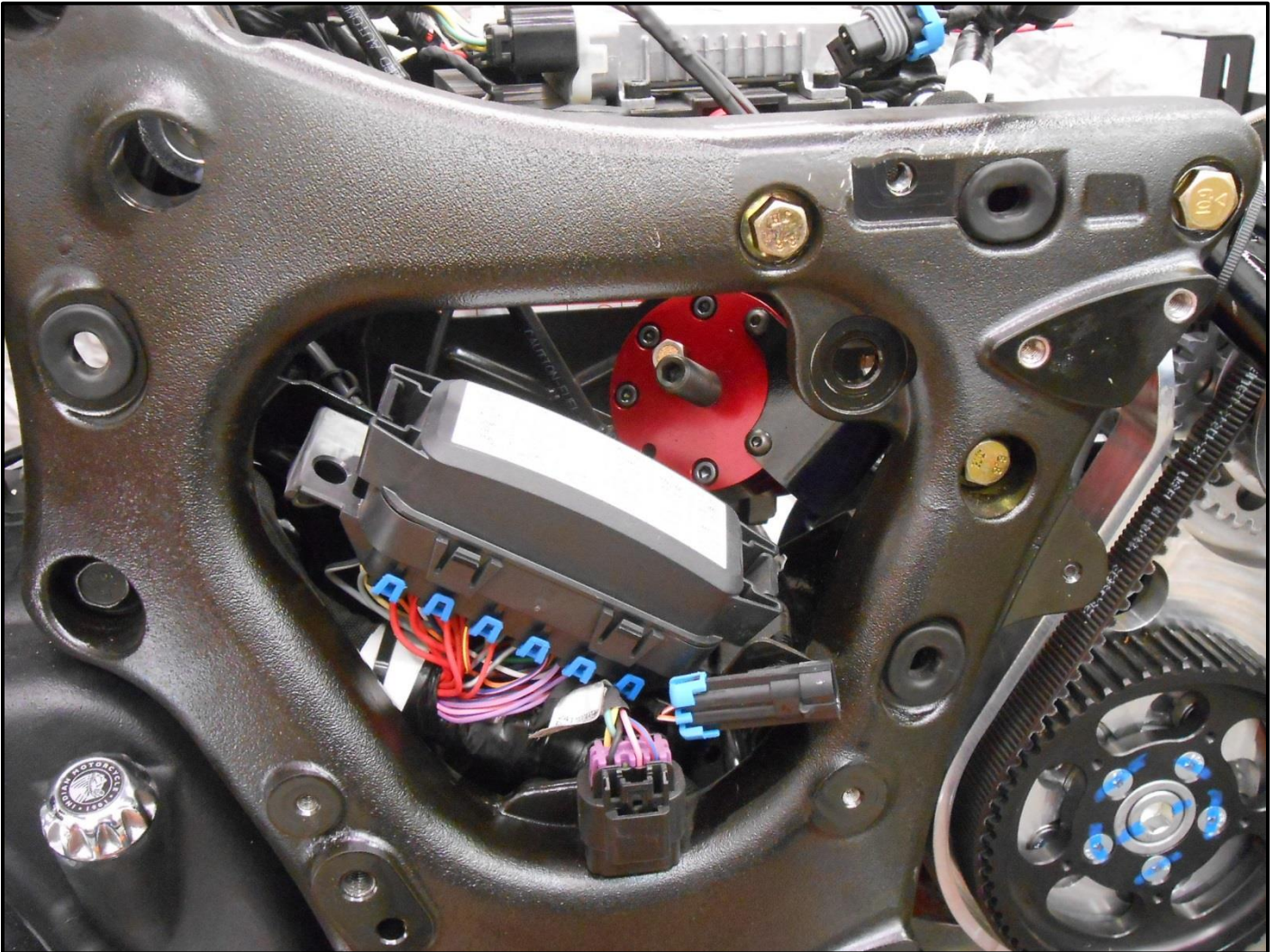

Suspension Setup

Use this chart to select the correct spring preload. Rotate the adjuster nut on the shock until the spring is set to the desired length. Now tighten the set screw on the adjuster nut, but do not over tighten.

Load: Typical weight the customer adds to the trike. This includes riders, luggage, and weight of a trailer tongue. When in doubt assume a higher weight than actual.

Length: Suggested length the spring should be adjusted to with the suspension completely unloaded, rear tires in the air, and the Preloader adjusted all the way out

ARROW								
SHOCK with RED SPRING								
	LOAD	LENGTH		LOAD	LENGTH		LOAD	LENGTH
250 LB/IN SPRING	100	13 1/16	300 LB/IN SPRING	100	13 1/4	350 LB/IN SPRING	100	13 7/16
	200	12 7/8		200	13 1/16		200	13 1/4
	300	12 5/8		300	12 7/8		300	13 1/8
	400	12 5/16		400	12 5/8		400	12 15/16
	500	12 1/8		500	12 7/16		500	12 3/4
				600	12 1/4		600	12 5/8
							700	12 1/2
							800	12 3/8

These lengths are only estimates. If you would like to confirm a correct setting, load the completed trike to the customer's typical riding situation and measure from the ground to the middle of the lower suspension plate. The center hole should be 5.75" – 6.25" from the ground. **Attention: This is the only suspension adjustment needed.** All other settings are factory set and should not be tampered with. There is no need to remove trike from the lift to check camber, toe, or the drop links.

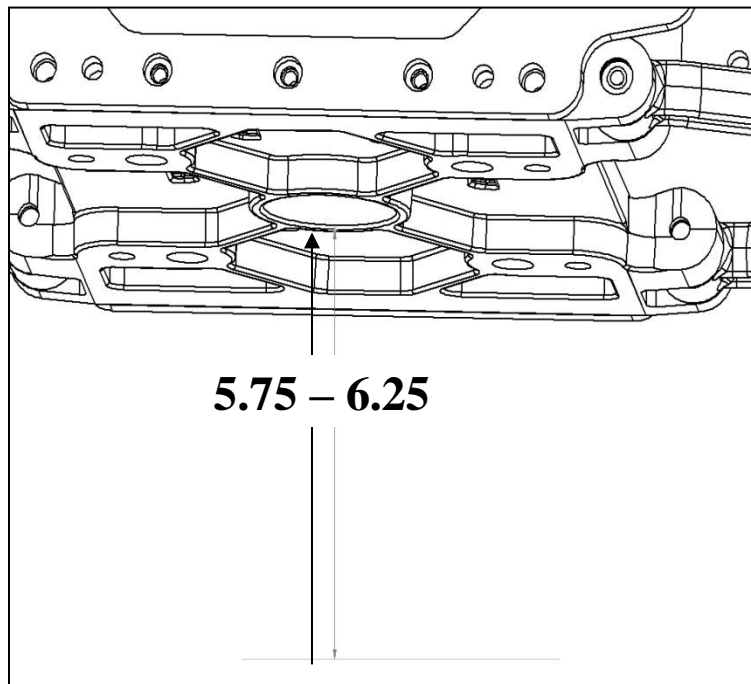

Trike Body Installation

1. Install OEM left lower Side Cover (3 fasteners)

2015-2016 Road Master Models only:

2. Install Amp on CSC bracket new fasteners & nyloc nuts

3. Lower the Amp into place into the body securing with S.S. BHCS, washers & nyloc nuts

Wires shown below are after the Tour Box is installed



4. Remove 4 hitch pins in order to remove the Wheel Skirts

5. Remove the Wheel Skirts

6. Lower the body onto the trike with the body lever until it comes to rest onto the upper tray and body frame

7. It will be necessary to grind the right lower Side Cover

Cut on Dotted line as shown

Before



After



Trike Body Alignment

- 1. The Trike Body can move left, right, forward, backward, up, down, and angled. Shimming with the provided 1/4 and 1/8 Rubber Washers may be required to get the Trike Body into alignment**
- 2. Now with all 4 Side Covers installed**

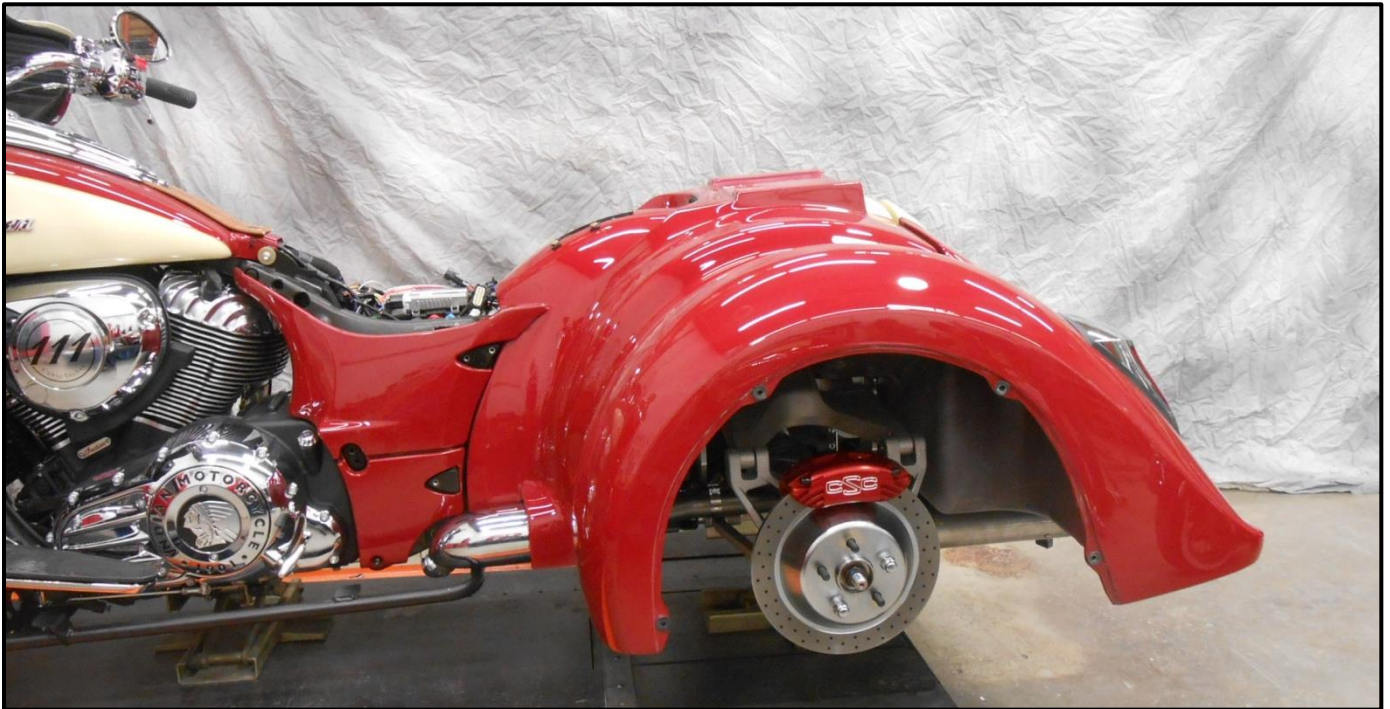

- 3. Raise the front of the body to align with the Side Covers to allow for an even gap**
- 4. With the body temporarily held into place, raise the adjustable 90° body support brackets until they seat against the body's inner liner, Tighten the two 5/16 – 18 x 3/4 HHCS and nyloc nuts on the Adjustable 90° Support Brackets**
- 5. Align the muffler with the muffler cutout in the body**
- 6. Center the Trike Body left to right measuring off the rotors with a carpenters square**
- 7. Reinstall the Exhaust Heat Shields**

Securing the Trike Body

Note: A small section of Trike Body Carpet has not been glued at the location of the Trike Body Frame mounting tabs to allow removal of the bolts used in shipping, and installation of the Trike Body mounting hardware. The predrilled bolt holes may need to be enlarged or relocated for Trike Body attachment to the Trike Body Frame mounting tabs. If relocation is necessary, the preexisting holes will need to be sealed with silicone sealant.

- 1. Using a 5/16 twist drill, drill up through the Trike Body Frame mounting tabs**
- 2. Insert 5/16–18 x 1 1/4 HHCS, fender washer, and rubber washers if necessary through the holes drilled**
- 3. Install nyloc nuts and flat washers onto the rear HHCS and tighten**
- 4. Using a 5/16 twist drill, drill up through the Adjustable 90° Body Support Brackets**
- 5. Insert 5/16–18 x 1 1/4 HHCS and fender washers through the adjustable 90° body support brackets.**
- 6. Install nyloc nuts and flat washers onto the front HHCS and tighten**
- 7. Re-align the Mufflers and tighten hardware**
- 8. Reinstall the 4 triangle shaped black plastic frame covers**
- 9. Use silicone to seal the shipping holes and to glue the carpet down**

Tour Box Installation

1. Lower the Tour Box in place on the body
2. Install 4 5/16x2 1/4 HHCS with flat washers in the center of the Tour Box, Secure with fender washers & nyloc nuts inside the body & tighten
3. Cut the Chrome bar as shown appox. 7 inches from the front of the bar

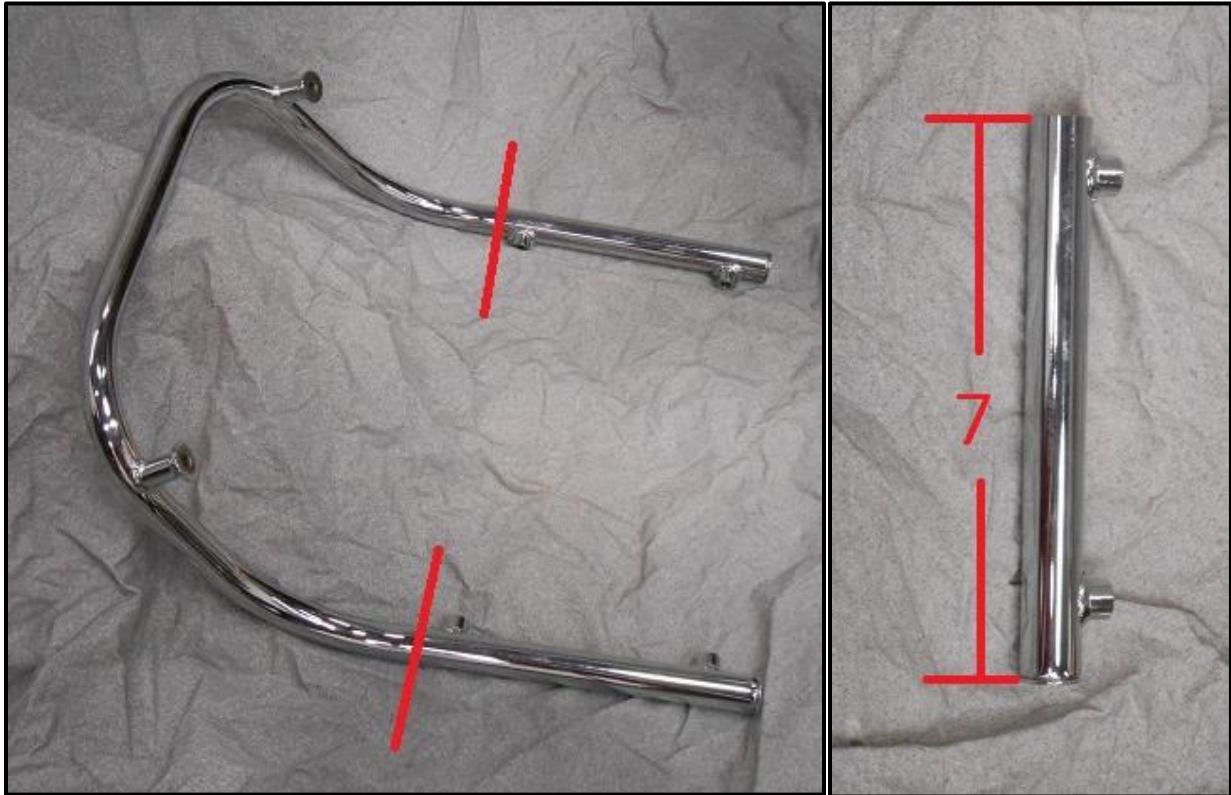

4. Install 2 well nuts in the cut end of the Chrome Bar
 5. Install the cut Chrome Bar with 2 5/16x1 3/4 HHCS, flat washers & the 2 OEM fasteners & washers & tighten
 6. Install 4 more 5/16x2 1/4 HHCS with fender washers in the perimeter holes inside the Tour Box now secure with fender or flat washer & tighten
- Radio Antenna equipped Motorcycles**
7. Drill a 5/16 hole 1 1/2 inches to the right of the chrome bar at the same height. Refer to picture

8. Drill a 7/16 hole in the front of the tour box for the antenna cable as shown
9. Split the grommet and install in hole
10. Route antenna wire with the rest of the wire harness, secure and plug in



11. Plug in the Tour Box harness to the Amp, now remove the wire extension from the seat and plug it into the Tour Box and the Motorcycle harness, then secure it
12. Reinstall the OEM liner

13. Before you install the seat you need to cut the openings in the front ¼ inch rearward so the seat will install and remove easier. Refer to picture below

BEFORE



AFTER





Final Assembly

1. Connect the fender plug to the trike body plug
2. Connect the **RED** fusible link wire on the Battery Harness to the positive battery post and the **BLACK** wire to the negative post. Plug the Battery Harness into the trike body.
3. Reinstall the battery box cover, seat and upper side covers
4. Reinstall the wheel and tire assemblies with ten m12 x 1.5 ET conical lug nuts. Torque to 75 FT-LBS
5. Reinstall the Wheel Skirts & secure them with 4 hitch pins
6. Recommended tire pressure
 - 15 & 16" wheels – 28 psi
 - 17" wheels – 25 psi

From all of us at California Sidecar.
Enjoy the ride.

**NOTE ABOVE CHANGE TO TRIKE INSTALLATION
INSTRUCTIONS**

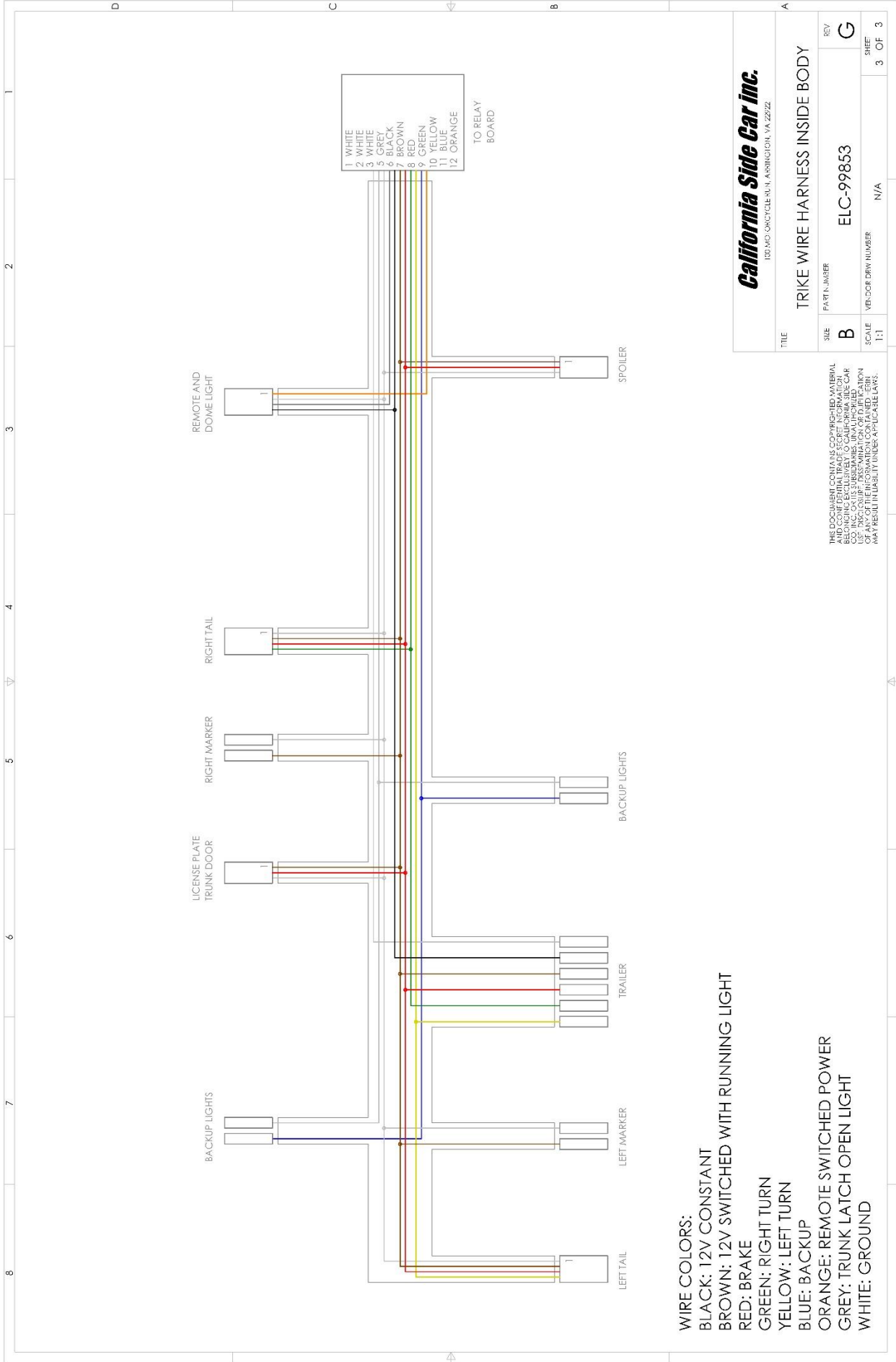

California Side Car Inc.
 100 MO. ORCHARD BLVD, ABBOTTSBURY, VA 22722

TITLE		TRIKE WIRE HARNESS INSIDE BODY	
SIZE	PART NUMBER	REV	
B	ELC-99853	G	
SCALE	VEHICLE DRIV NUMBER	SHEET	3 OF 3
1:1	N/A		

THIS DOCUMENT CONTAINS CONFIDENTIAL MATERIAL AND CONFIDENTIAL TRADE SECRET INFORMATION. REPRODUCING, EXCERPTING, OR DISTRIBUTING THIS INFORMATION WITHOUT THE WRITTEN PERMISSION OF CALIFORNIA SIDE CAR INC. IS PROHIBITED. THIS INFORMATION OR DISTRIBUTION MAY RESULT IN LIABILITY UNDER APPLICABLE LAWS.