



Trike Conversion Kit for

INDIAN MOTORCYCLES

CLASSIC - VINTAGE - DARKHORSE
CHIEFTAN & ROADMASTER MODELS
2014 - CURRENT

Installation Instructions

Revised 8/18/2021

California Sidecar Parts & Technical Support
434.263.6500

Table of Contents

Warnings and Considerations	3
Disassembly of Motorcycle	4
Trike Component Installation	12
Brake Line Installation	13
Rear Suspension Unit Installation	14
Rear Brake Bleeding Procedure	17
Abs Wheel Speed Sensor	18
Muffler and Tailpipe Installation	19
Link to CSC Belt Tensioning video	21
Setting up the Sonic Tension Meter	21
Using the Sonic Tension Meter	21
Tensioning the Front Drive Belt	22
Tensioning the Rear Drive Belt	23
Shock Spring Preloader Installation	25
Suspension Setup	26
Trike Body Installation	28
Trike Body Alignment	30
Securing the Trike Body	31
Tour Box Installation	32
Final Assembly	36

Warnings and Considerations

Disclaimer - These instructions assume a level of understanding of motorcycle repair and maintenance beyond that of a "beginner" and/or "novice" and California Sidecar cannot be liable for an installer's failure to understand or follow these instructions as written. Likewise, California Sidecar cannot be responsible if any of the steps are omitted or shortcuts are taken, or parts other than those supplied by California Sidecar, are used in installing this trike kit.

1. "WARNINGS" are all printed in bold type and capitalized. They mean to use extreme care in a given step so as not to damage the part, motorcycle, and/or yourself.
2. Always wear safety glasses when using hand and/or power tools.
3. When working in and around the fuel system, always work in a well-ventilated area, free from sparks and open flames.
4. All directional references to the "right side" and the "left side" are as you were seated on the motorcycle.
5. All directional references to "forward" mean to the front of the motorcycle while "back" means the rear of the motorcycle unless otherwise stated.

Recommended Lubricants:

1. Thread locking compound (Loctite 242 minimum).
2. High temperature Silicone sealant.

Service & Maintenance questions – contact Parts & Service at 434.263.6500

Disassembly of Motorcycle



1. Remove & save the top Side Covers
2. Remove & discard Saddle Bags (if equipped)
3. Remove & save the Seat (3 fasteners)
4. Disconnect the Negative Battery Cable



Models with Tour Box:

1. Remove & save the Tour Box (10 Fasteners on the floor, two at the rear ((Chrome Bar)) and one wire plug)
2. Remove & save the Chrome Bar (4 Fasteners)



3. Remove the Quick Disconnect Bracket

2015-2016 Models only:

1. Remove & save the Radio Amp and harness

All Models:

1. Remove & save the Exhaust Heat Shields
2. Remove & save the Passenger Pegs or Floorboards
3. Remove & save the bottom Side Covers
4. Remove & discard the rear Highway Bars (if equipped)
5. Remove & save the 4 small triangle shaped black plastic Frame Covers & fasteners (if equipped)



6. Remove & discard the Side Stand
7. Remove & discard the Antenna and its mount
8. Remove & discard the Mufflers, saving the Clamps



Remove & Discard Rear Fender:

1. Disconnect Fender wiring plug
2. Remove & discard the 4 Saddlebag mounting Cylinders
3. Remove Chrome Frame Covers (2 fasteners each)
4. Loosen 4 fasteners inside the rear of Fender
5. Remove 2 fasteners in front & 1 on top, on each side
6. Remove Fender
7. Save the two Grommet fasteners on the RT side
8. Remove & discard the Passenger seat strap (if equipped)
9. Remove & save the Tip Over Sensor & it's hardware
10. Remove & discard the plastic inner fender



11. Remove the rear Brake Caliper (2 fasteners)
12. Remove & save the Rear Wheel Speed Sensor (1 fastener & shim)
13. Remove & save the Front Sprocket Cover (4 fasteners)
14. Remove & discard the Rear Shock pivot shaft
(Remove snap ring, now thread in a M5 bolt and use it to pull out the shaft)

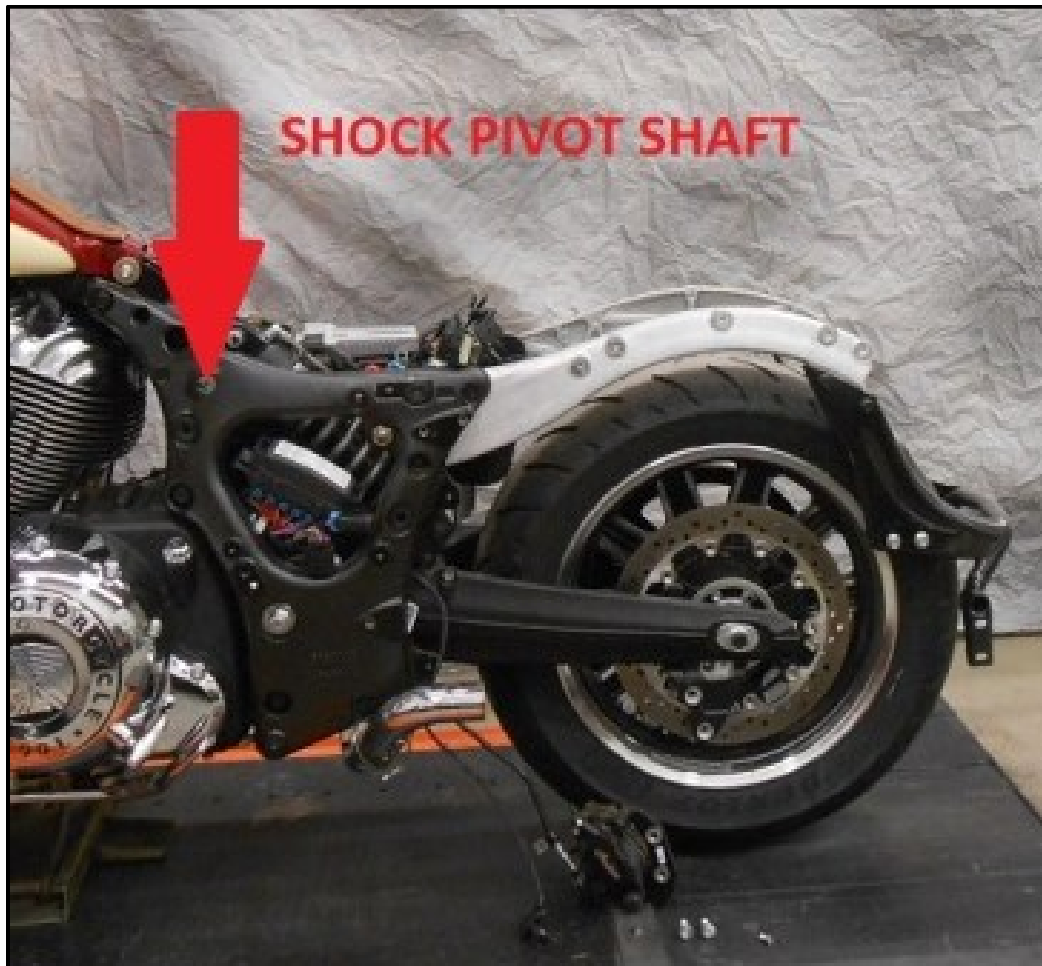

15. Remove the nut on the Rear Shock air line
16. Remove & save the Swing Arm Pivot Shaft.
Remove the left side Nyloc Nut, then the right side Jam Nut & last unthread the Pivot Shaft
17. Remove Drive Belt from Front Sprocket

Remove Subframe & Swing Arm:

1. Remove and save the 3 fasteners on the rear of the Battery Box
2. Loosen 5 fasteners on the left side of frame shown in **RED 1 – 5**
3. Remove 6 fasteners on the rear Subframe shown in **BLUE 1 – 3 on both sides**
Save fasteners 1 and 3 both sides.
4. Spread the frame apart and remove rear Subframe



5. Remove and discard Swing Arm, wheel, shock & belt as an assembly

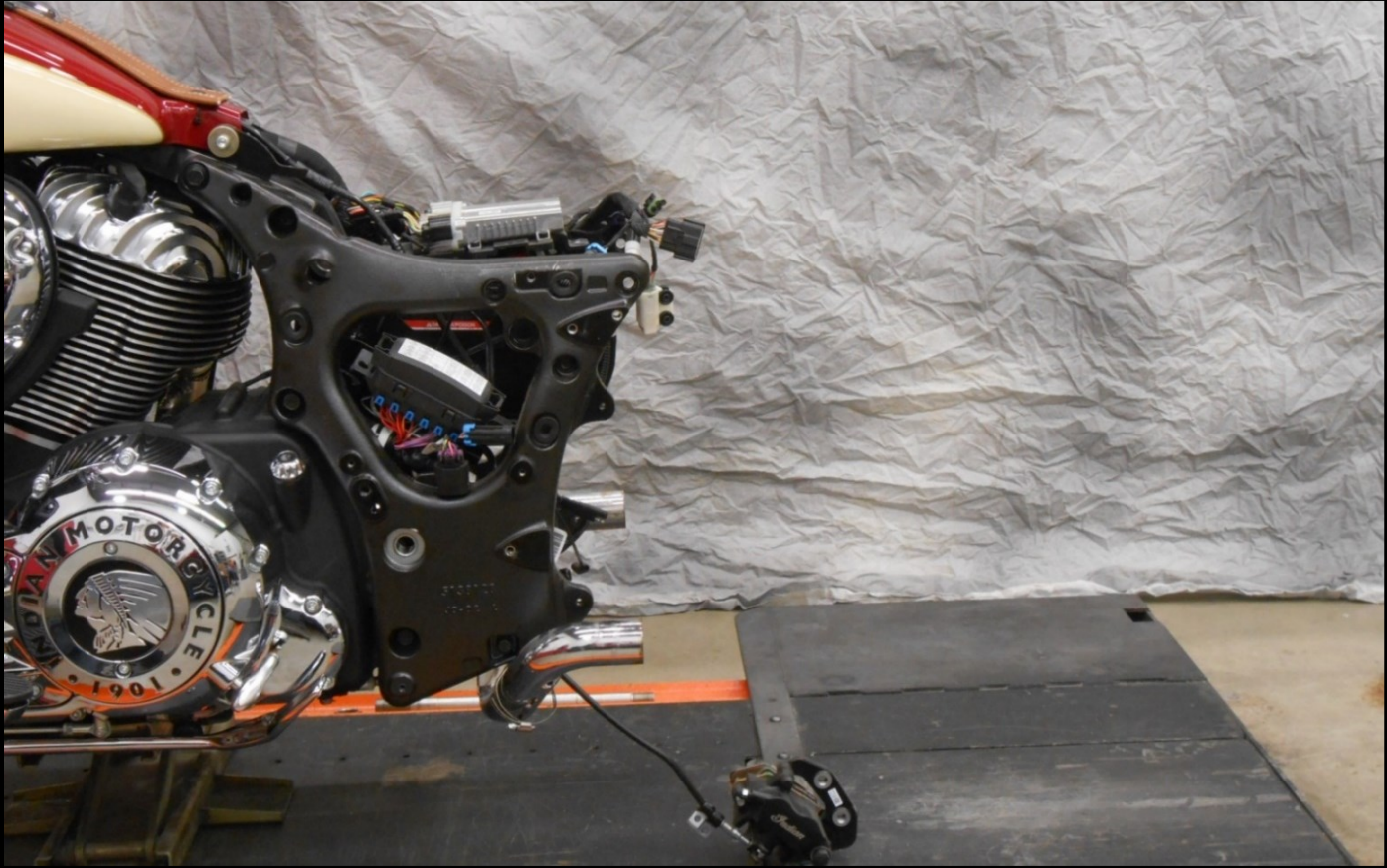

Trike Components Installation

1. Install **NEW CSC** Belt on Front Sprocket
2. Reinstall the Front Sprocket Cover
3. Lightly tap 2 hollow Dowels into the upper rear holes of the Upper Cross Brace
4. Install Upper Cross Brace
5. Reinstall 4 OEM fasteners in the upper front and lower rear holes with flat washers and nyloc nuts, leave loose.
6. Lightly tap the Hollow Dowels into the Motorcycle frame
7. Install 2 M10x70 Flange head bolts in the upper rear holes as shown
8. Install the 3 OEM fasteners in the battery box and its cover
9. Reinstall the Grommet fasteners on the right side using an OEM washer & a new washer

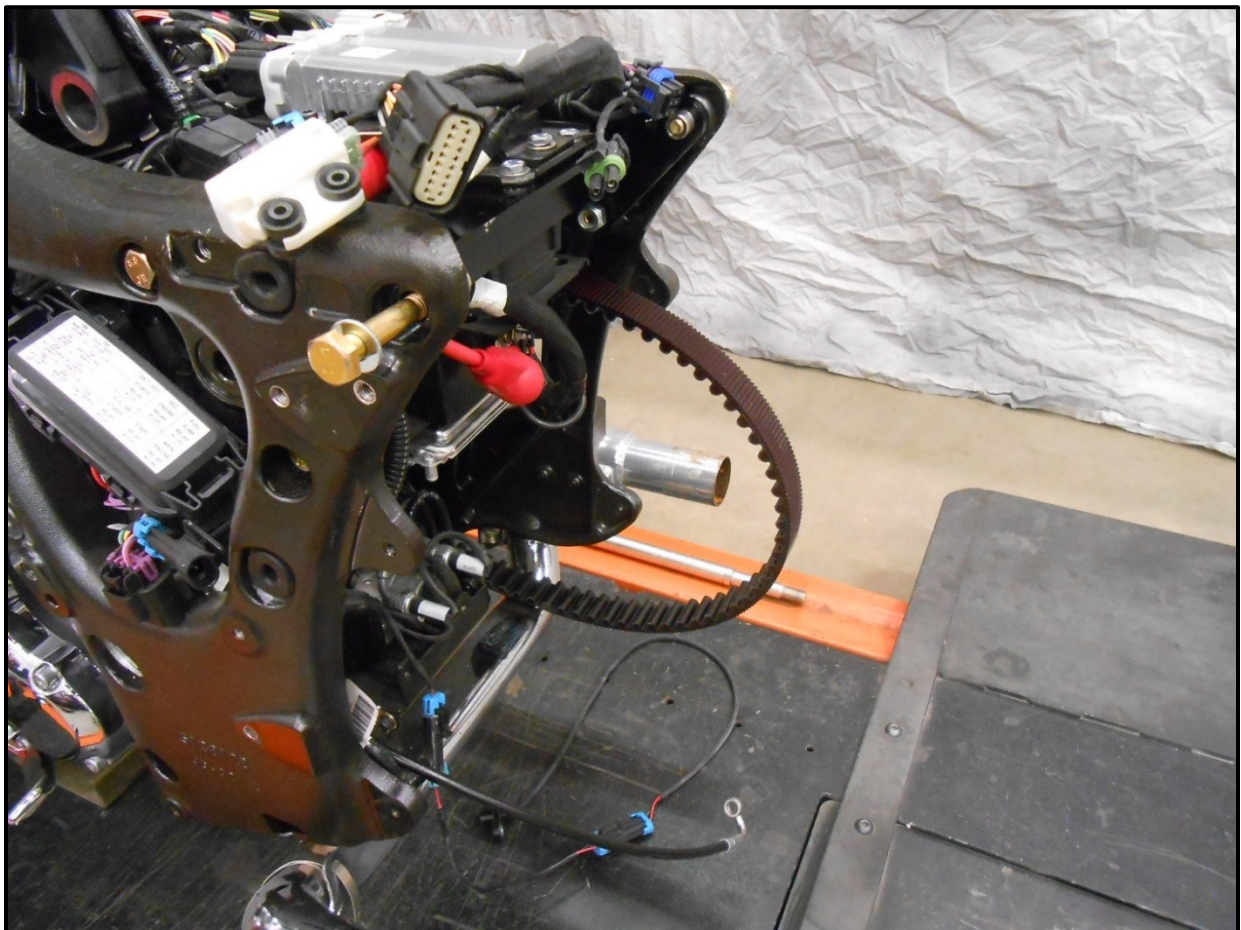

Brake Line Installation

1. Remove & Discard OEM Brake Line and Caliper
2. Install new CSC Brake line reusing **OEM** Banjo Bolt though the straight fitting with 2 new crush washers

2015-2017 models: Plug in the Wheel Speed Sensor Extension then the OEM Wheel Speed Sensor

2018 and newer models: Plug in the ABS Signal Conditioner.

3. Leave both the Brake Line and sensor wire so they go under the Drive Support

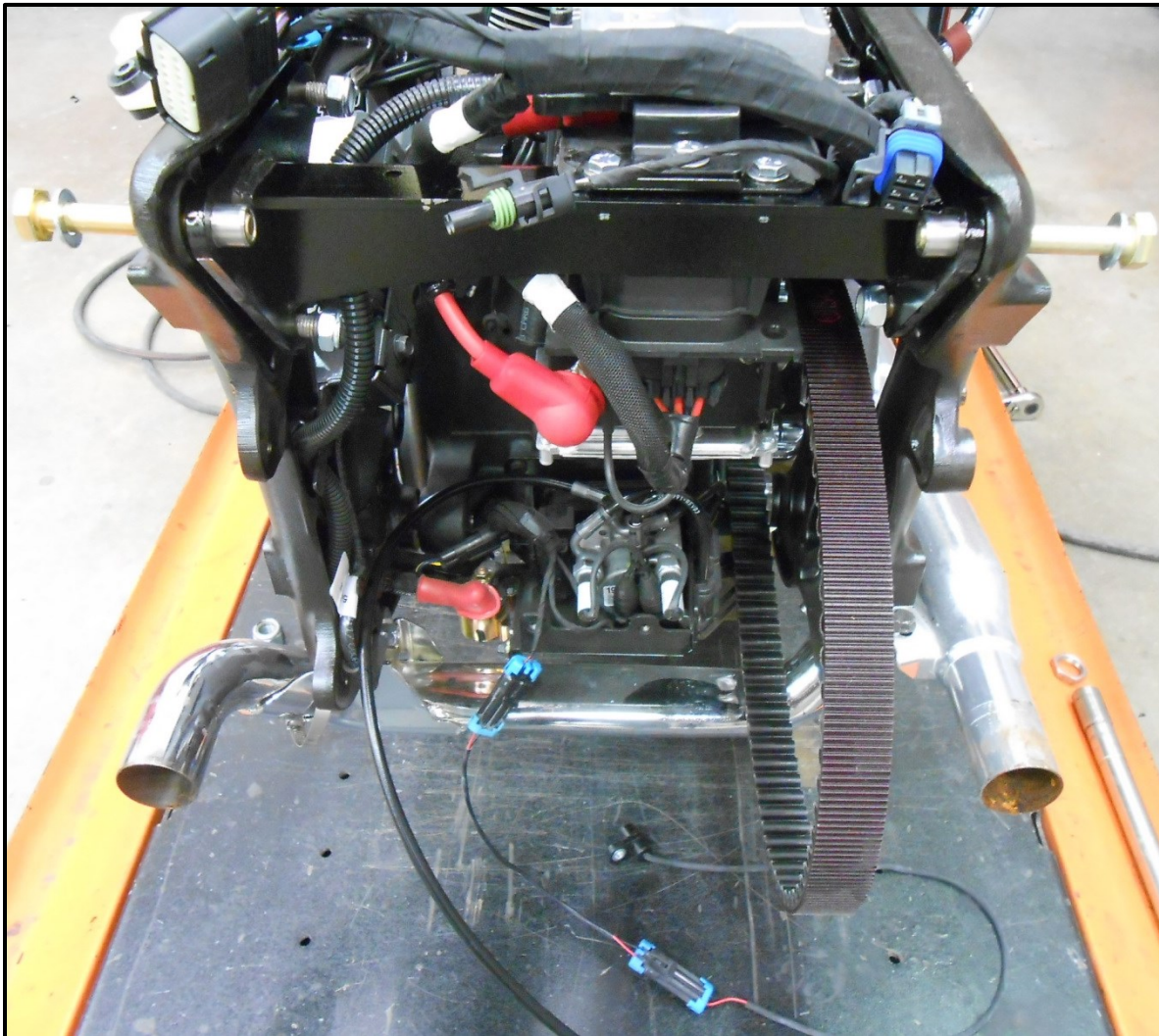

Rear Suspension Unit Installation

1. Position Trike Suspension Unit behind prepared motorcycle frame
2. Install CSC Belt on Drive Sprocket
3. Reinstall the Tip Over Sensor with OEM hardware
4. Install the stud plate up through the Cross Frame Brace, Tip Over Sensor on top and secure with nut and washer
5. Make sure the "UP" is up on the Tip Over Sensor

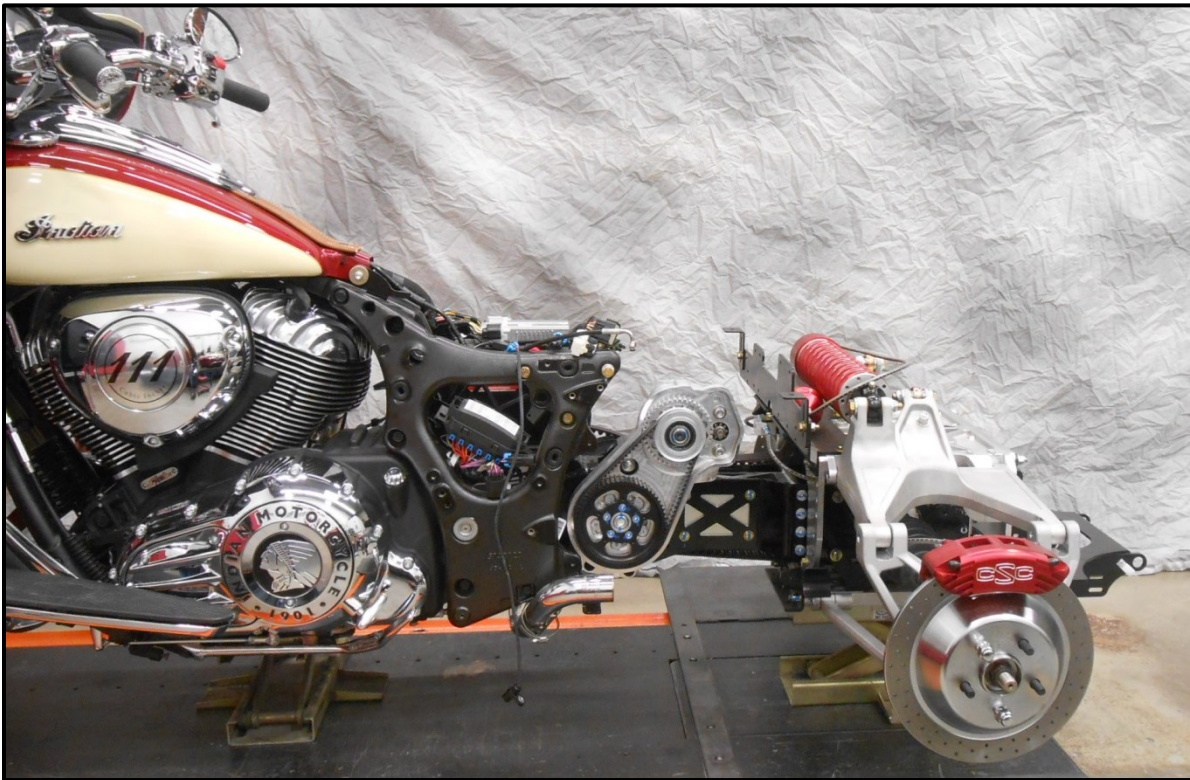

6. Install Swing Arm Pivot Shaft & thread it in until you have approximately 1 inch of threads still sticking out on the right side
7. Loosely install the Frame Mounts over the Dowels on the Upper Cross Brace

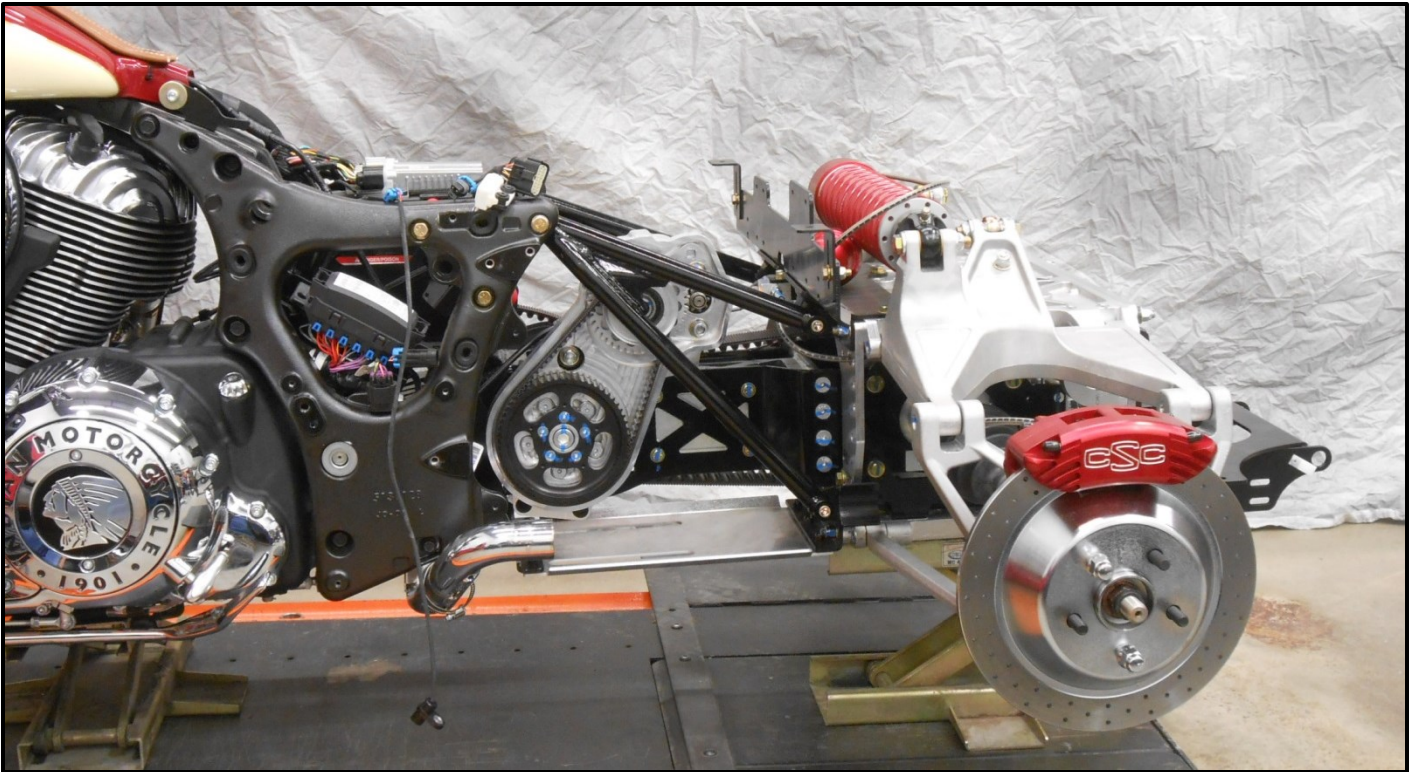

8. Push Suspension forward to align with Frame Mounts
9. Loosely install 4 3/8 SHCS in the rear of both Frame Mounts
10. Install nyloc nuts & flat washers on the 2 M10 & 4 3/8 fasteners on the Frame Mounts
11. Tighten Fasteners in this order
 - a. OEM motorcycle frame (5 fasteners)
 - b. Upper Cross Brace (6 fasteners)
 - c. Rear Frame Mount (4 fasteners)
 - d. OEM Pivot Shaft

Tighten pivot shaft until it bottoms out, then back it off 1/2 turn. Next tighten the right side Jam Nut, and lastly tighten the left side nyloc Nut. After tightening there should be approx. 3 threads out on the right side and 1- 2 threads out on the left side.

12. Route the CSC Brake Line up the left side of the Drive Support, then to the outside of the left Frame Mount, then to the Distribution Block. Attach fitting to Distribution Block with a new Banjo bolt and 2 new crush washers. Secure with zip ties as shown below.



Rear Brake Bleeding Procedure

1. Using Indian recommended brake fluid, fill Rear Brake Master Cylinder Reservoir
2. Using a vacuum bleeder, follow this procedure carefully
3. Rear facing Bleed Valves outsides first then insides on each side
4. Front facing Bleed Valves outsides first then inside on each side
5. Hand bleed the system using the above sequence until all air is removed from the lines
6. Allow the bike to sit for a minimum of 20 minutes and recheck the pedal travel
7. If there is excessive pedal travel on the first pump, repeat steps 3 and 4
8. When complete reinstall the bleeder caps



ABS Wheel Speed Sensor Installation

1. Install the OEM ABS Wheel Speed Sensor with OEM SHCS and shims if needed (air gap 0.065in to 0.080in)

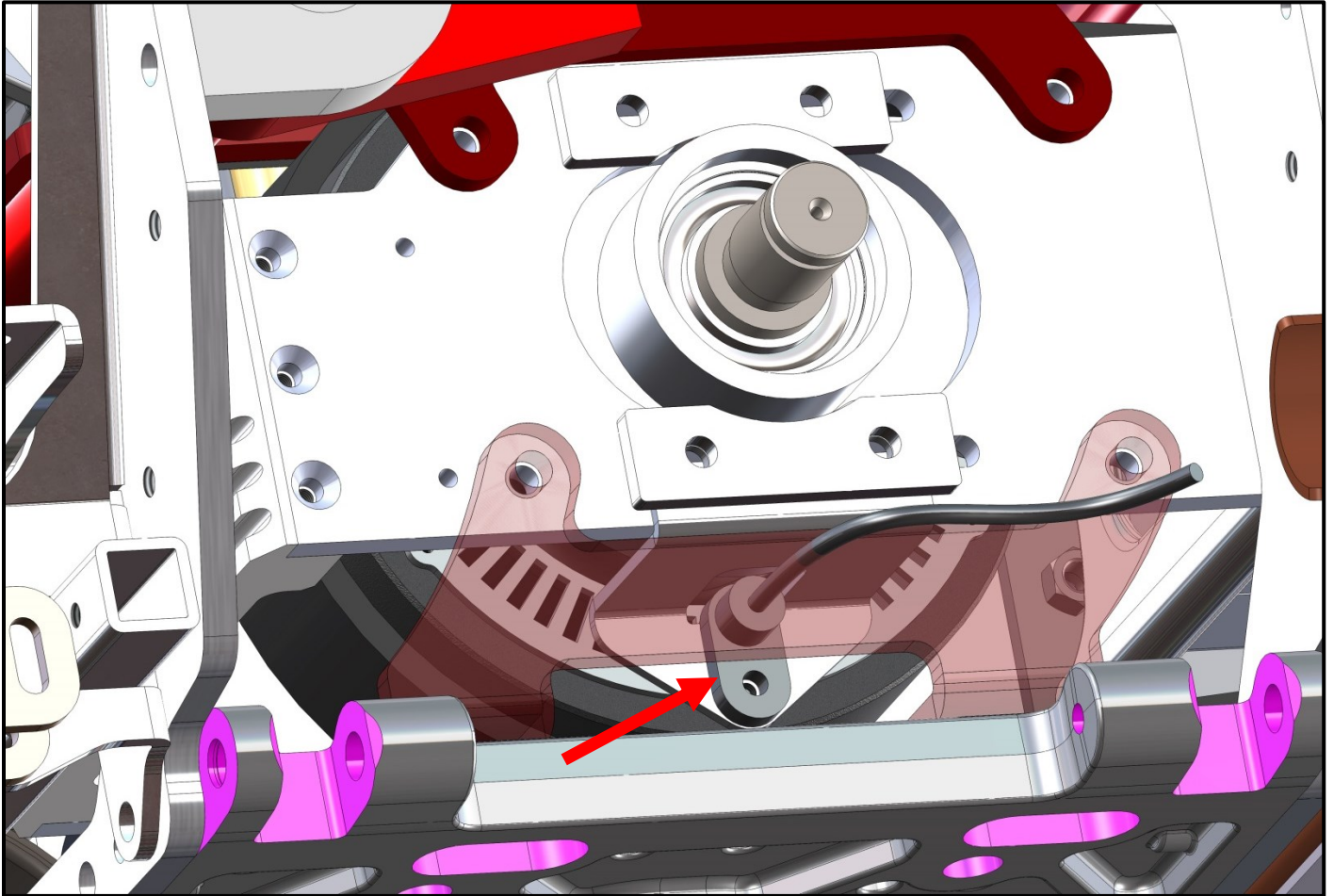

2014-2017 Install the provided Extension wire.

2018-UP ABS SIGNAL CONDITIONER:

1. Plug in the CSC module between the ABS sensor and the motorcycle ABS system.
2. Secure the CSC module to the intermediate mount.
3. Once the Trike Body is installed plug in the 4 pin T Harness to the GFX plug on the Trike Body Harness.
4. Secure the Sensor wires and the CSC module wires with zip ties.

Muffler and Tailpipe Installation

1. Install Muffler Mount using three 5/16-18X1 1/4 HHCS, 6 flat washers and 3 nyloc nuts in the lower set of holes
2. If installing the Trailer Hitch Option, install it now

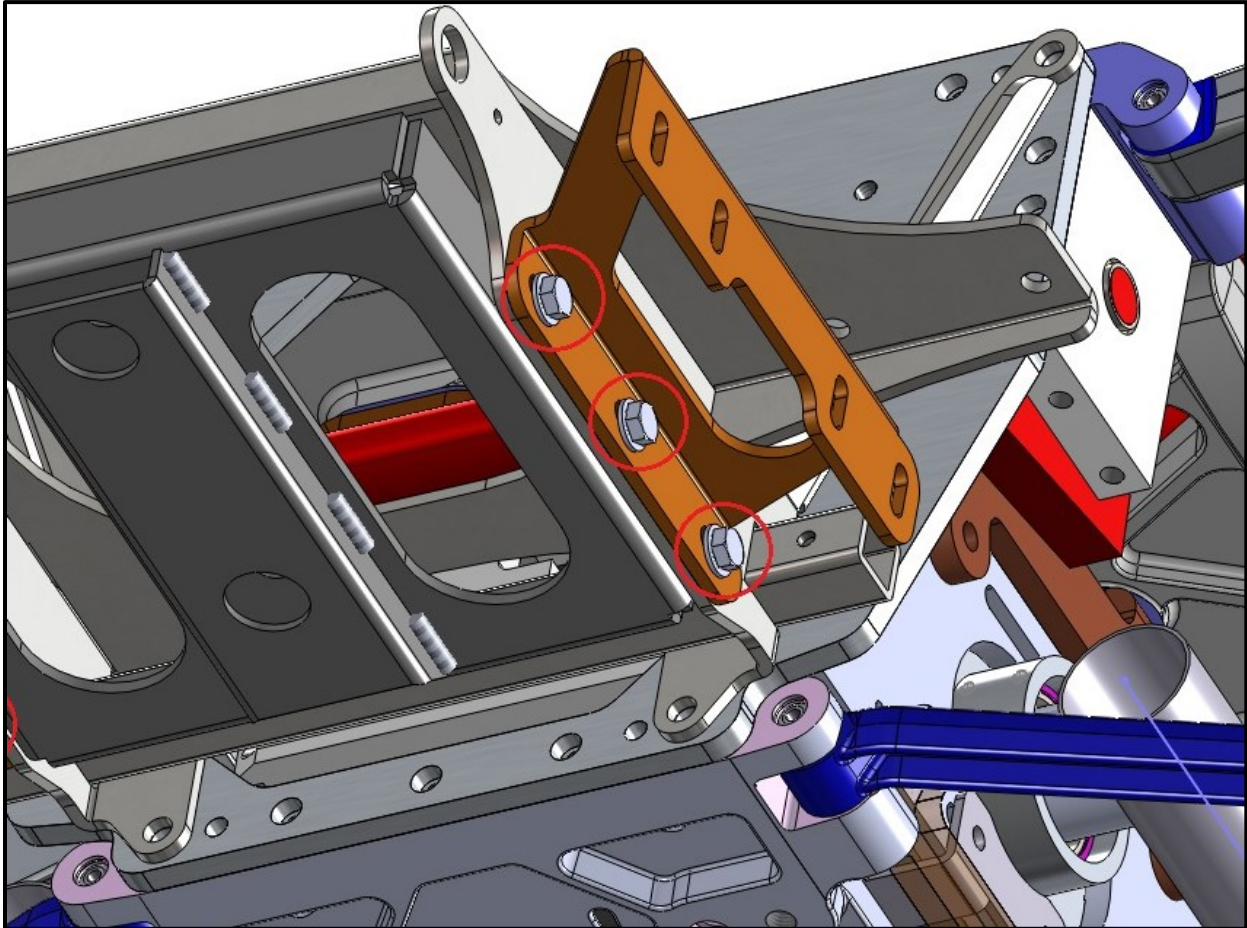

3. Loosely install CSC Tailpipes onto the rear of the OEM Head Pipes, reusing the OEM clamps and a new clamp on the lower front mount saddle
4. Install the CSC Muffler onto the tailpipe securing it to the muffler mount with two 5/16-18X3/4 HHCS and flat washers, and to the tailpipe with a new clamp
5. Tighten clamps but leave the 2 HHCS securing the mufflers loose to be tightened after the body is installed

Install the Electric Reverse now if equipped
Refer to separate instructions

Install the GRD EFX Mounts now if equipped
Refer to separate instructions

Link to CSC Belt Tensioning video

<http://www.californiasidecar.com/support.html>

Setting up the Sonic Tension Meter

1. Turn power on, Push Select then 1
2. Using the charts below in Front and Rear belt tensioning push Mass, then the numbers, Width and so on
3. For the Rear belt, push Select then 2. Reverse belt can be number 3 and so on

Using the Sonic Tension Meter

1. Using the Sonic Tension Meter
2. The microphone placement over the belt is critical
 - a. The microphone should be in the middle of the belt width-wise
 - b. The microphone should be held midway between the two Sprockets
 - c. The microphone should be between $\frac{1}{4}$ and $\frac{1}{2}$ an inch above or below the Belt
3. Ensure that the correct setting is displayed on the LCD screen
4. Push MEASURE, then gently tap the Belt with a wrench while holding the microphone in the correct position. A measurement in Lbs. of single span tension should display. If not, continue tightening the Belt until a reading is displayed
5. In noisy environments the Sonic Tension Meter may display errant numbers. If so, use in a quieter area
6. Always take at least THREE readings of the Belt tension and average the THREE readings to determine the actual tension of the Belt

Tensioning the Front Drive Belt

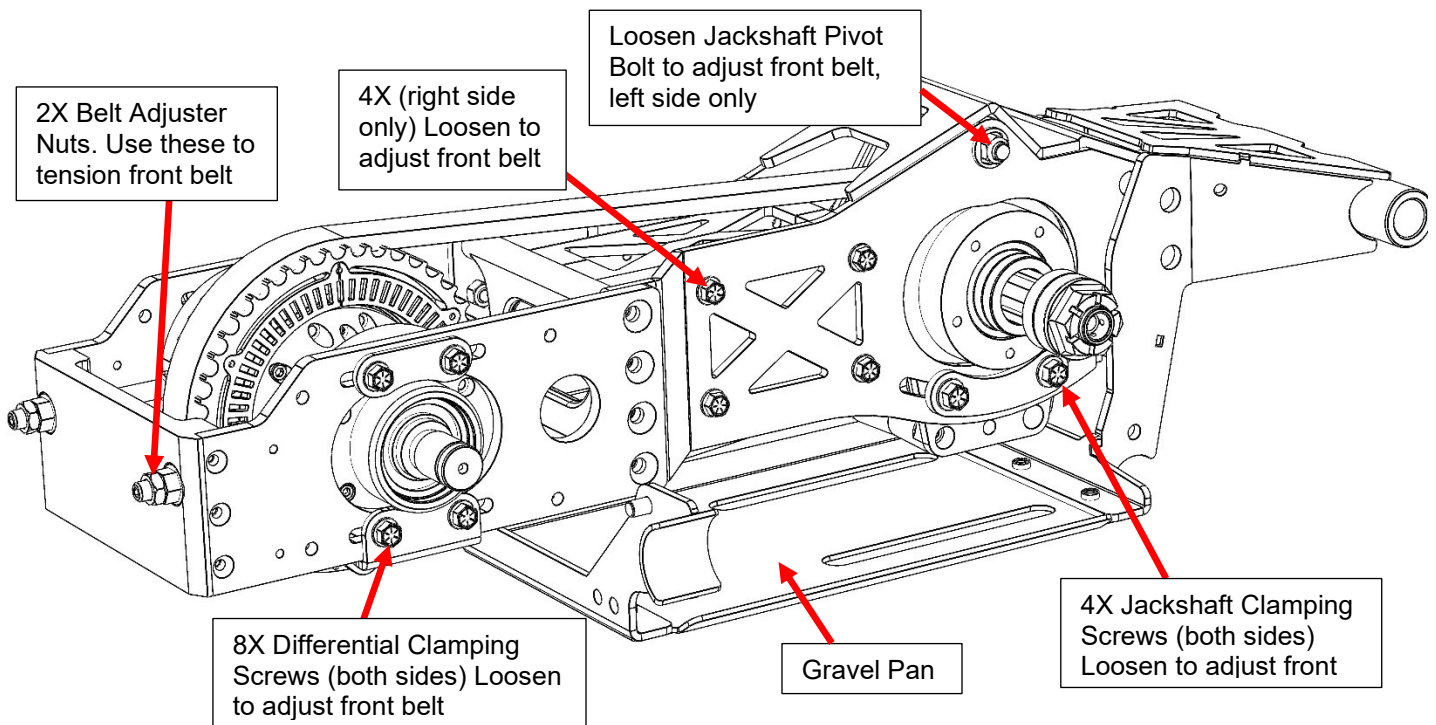

1. With the four HHCS in the rear only on the right side loose. Loosen the four clamping HHCS two per side.
2. Tighten the Rear Drive Belt adjuster nuts until the slack is taken up on the Front Drive Belt.
3. Use the correct setting on the Sonic Tension Meter.
MASS 007.9g/m
WIDTH 028.0 mm/R
SPAN 0434 mm
4. Check Front Drive Belt tension.
28mm Belt: 130 – 150 lbs. of single span tension.
5. Once the correct belt tension is achieved tighten all fasteners loosened or left loose in step 1, Eight HHCS and check the upper pivot shaft nyloc nut.
6. Verify belt tension. NOTE: Belt tension may increase once all bolts are tightened.
7. **Install Gravel Pan with six included 1/4-20 bolts.**

Tensioning the Rear Drive Belt

1. See diagram below.

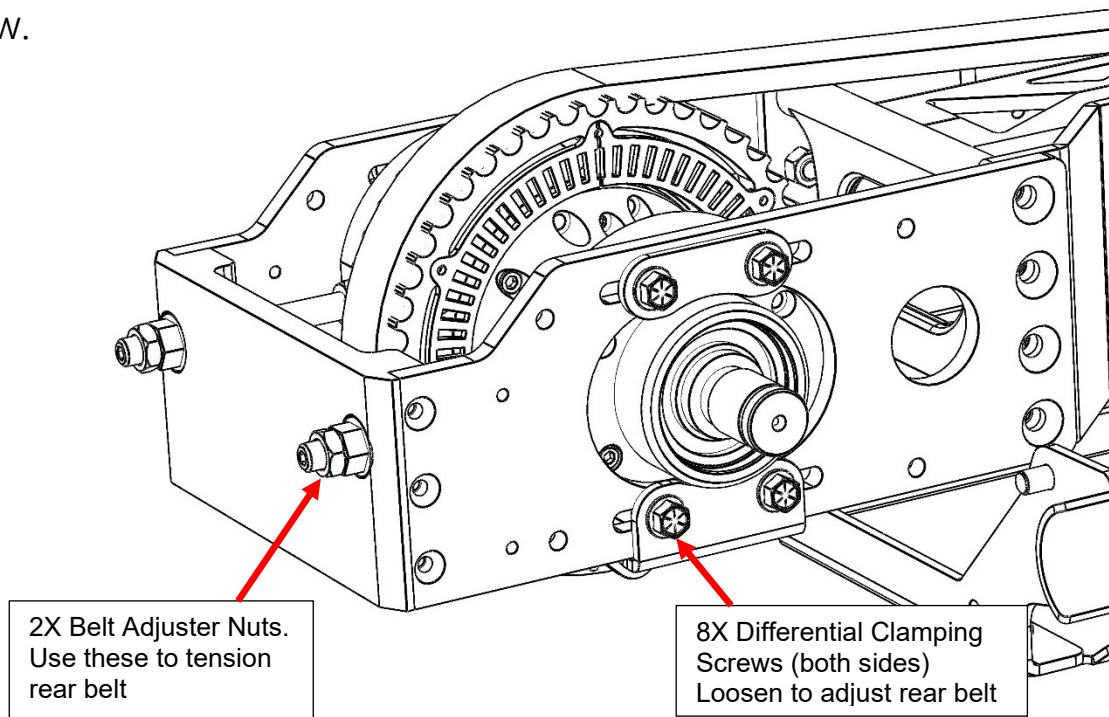

2. Tighten the Rear Drive Belt Adjuster nuts until the slack is taken up on the Rear Drive Belt.
3. Use the correct setting on the Sonic Tension Meter.
MASS 007.9 g/m
WIDTH 050.0 mm/R
SPAN 0442 mm
4. Check Rear Drive Belt tension.
50mm belt: 130 – 150 lbs. of single span tension.
5. In the next step you are going to run the engine. Please be aware of the safety of all those involved. Make sure you have at least two lug nuts on each brake rotor and that they are tight.
6. To finish alignment, the belt must have visual clearance between edge of belt and fence on front Rear Drive Sprocket. Check this by starting the engine and placing it in second gear and simply let the engine idle. Checking the alignment by eye and centering the belt as it spins. If belt

has the correct clearance, go to step 8. If it does not have clearance, proceed to step 7.

7. Use the Left and Right Rear Drive Belt Adjuster Nuts to align belt in order to achieve the necessary belt clearance. NOTE: The belt will always track to the side of the sprocket that is the loosest. Repeat step 4.
8. Once the correct belt alignment and single span tension is achieved, tighten the eight 5/16 – 18 x 1 ¼ Hex Flange Bolts that go into the Carrier Bearing Support Housings.
9. Install two 7/16 – 14 hex jam nuts onto the Rear Drive Belt Tensioning Studs and tighten.
10. Verify belt tension and alignment.
11. If the tension is correct move on to next step. If not, loosen clamping bolts and return to step 4.

Shock Spring Preloader Installation

1. Raise the Preload Adjuster into the bracket as shown and secure with 2 10-32 X 1 BHSCS

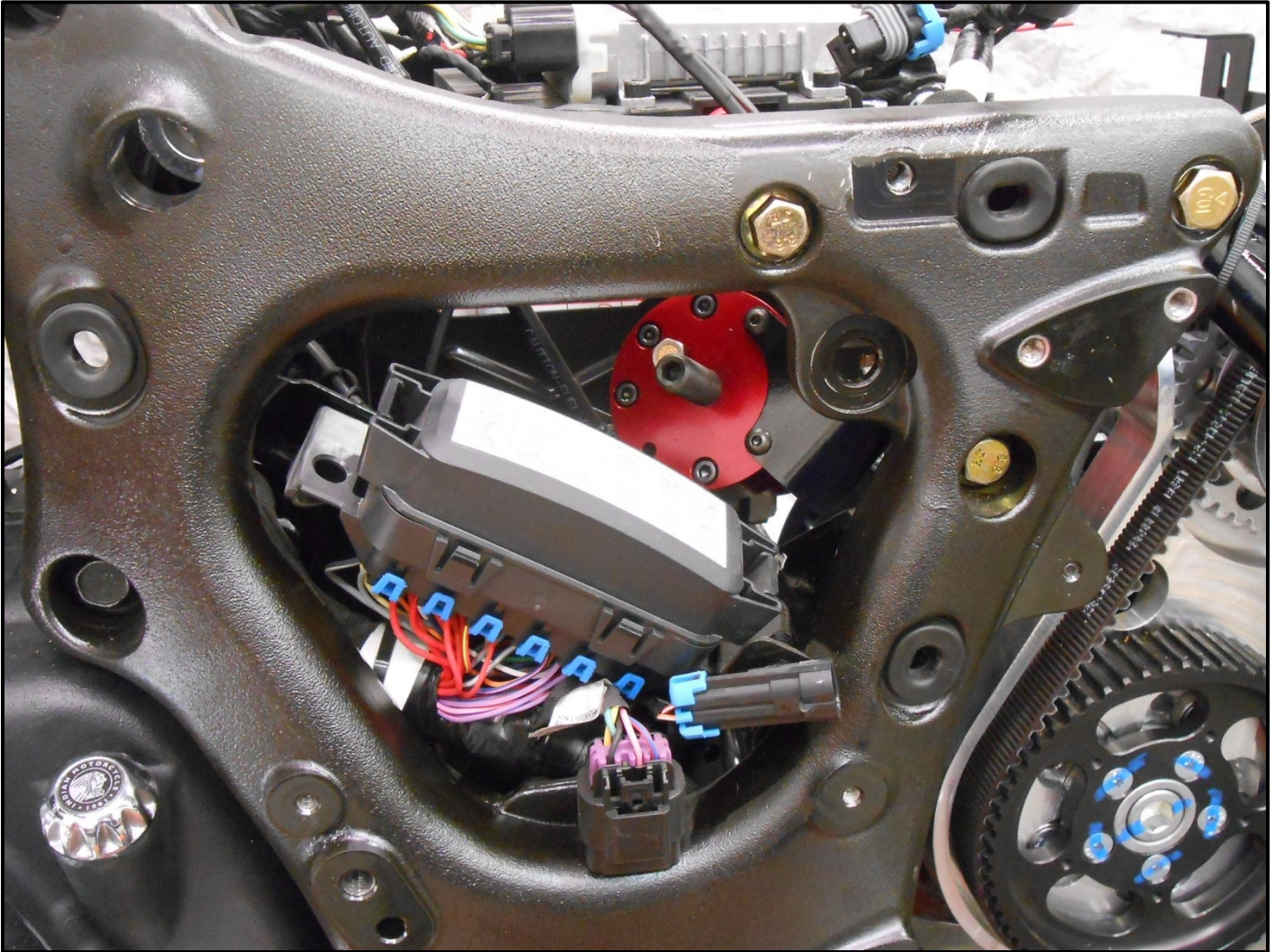

Suspension Setup

Use this chart to select the correct spring preload. Rotate the adjuster nut on the shock until the spring is set to the desired length. Now tighten the set screw on the adjuster nut, but do not over tighten.

Load: Typical weight the customer adds to the trike. This includes riders, luggage, and weight of a trailer tongue.

When in doubt assume a higher weight than actual.

Length: Suggested length the spring should be adjusted to with the suspension completely unloaded, rear tires in the air, and the Preloader adjusted all the way out

ARROW								
SHOCK with RED SPRING								
	LOAD	LENGTH		LOAD	LENGTH		LOAD	LENGTH
250 LB/IN SPRING	100	13 1/16	300 LB/IN SPRING	100	13 1/4	350 LB/IN SPRING	100	13 7/16
	200	12 7/8		200	13 1/16		200	13 1/4
	300	12 5/8		300	12 7/8		300	13 1/8
	400	12 5/16		400	12 5/8		400	12 15/16
	500	12 1/8		500	12 7/16		500	12 3/4
				600	12 1/4		600	12 5/8
							700	12 1/2
							800	12 3/8

These lengths are only estimates. If you would like to confirm a correct setting, load the completed trike to the customer's typical riding situation and measure from the ground to the bottom edge of the rear suspension plate. This distance should be 5.75" – 6.25" from the ground.

Attention: This is the only suspension adjustment needed. All other settings are factory set and should not be tampered with. There is no need to remove trike from the lift to check camber, toe, or the drop links.

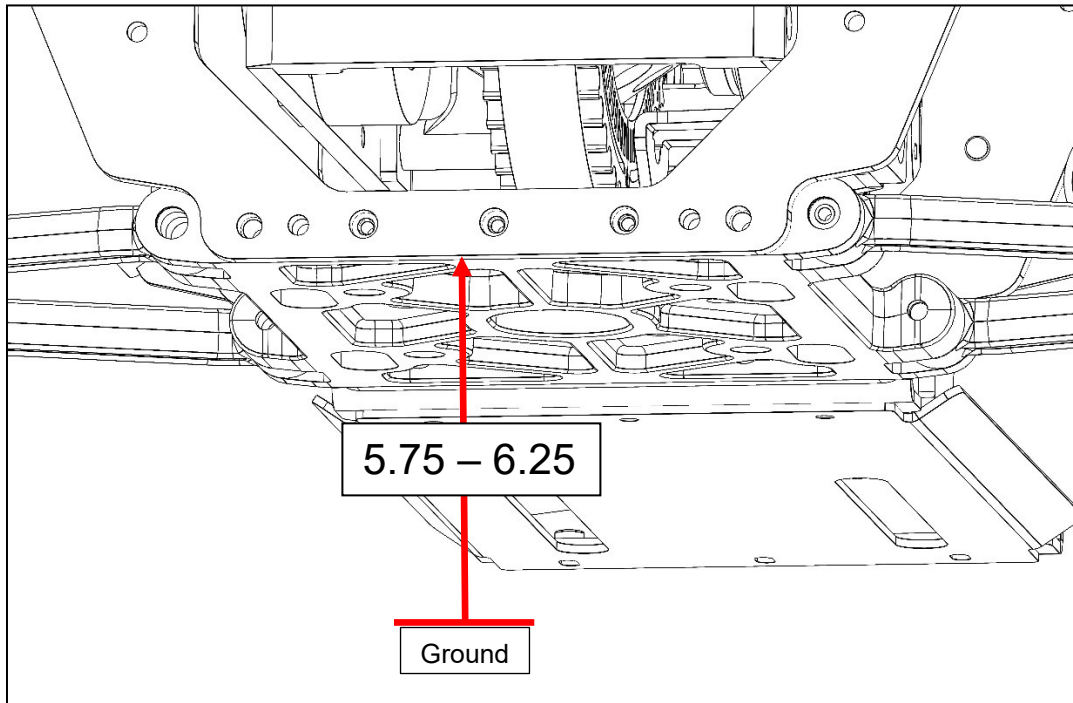

Trike Body Installation

1. Install OEM left Lower Side Cover (3 fasteners)

2015-2016 Road Master Models only:

2. Install Amp on CSC bracket with new fasteners & nyloc nuts
3. Lower the Amp into place into the body securing with S.S. BHCS, washers & nyloc nuts

Wires shown below are after the Tour Box is installed



4. Remove 4 hitch pins in order to remove the Wheel Skirts
5. Remove the Wheel Skirts
6. Lower the body onto the trike with the body level until it comes to rest onto the Upper Tray and Body Frame

7. It will be necessary to grind the right Lower Side Cover.
Cut on Dotted line as shown

Before



After



Trike Body Alignment

1. The Trike Body can move left, right, forward, backward, up, down, and angled. Shimming with the provided 1/4 and 1/8 Rubber Washers may be required to get the Trike Body into alignment
2. Now with all 4 Side Covers installed

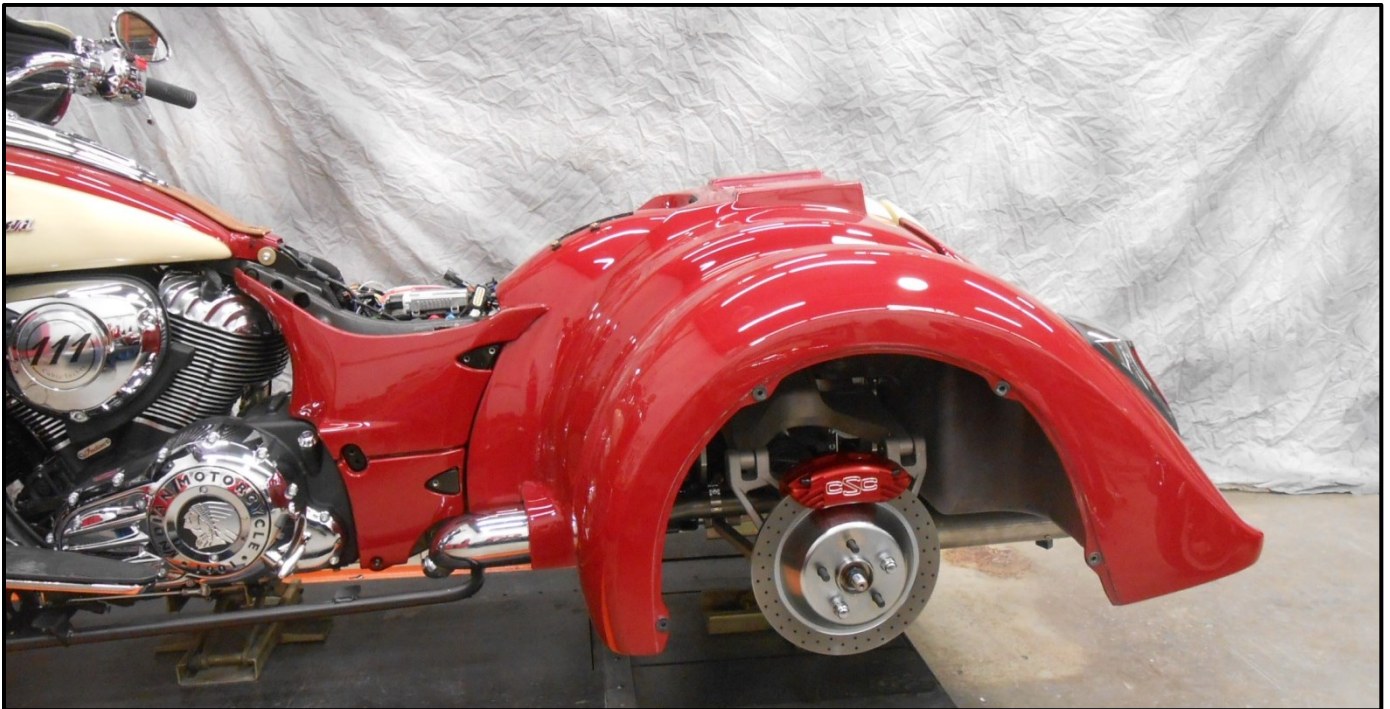

3. Raise the front of the body to align with the Side Covers to allow for an even gap
4. With the body temporarily held into place, raise the adjustable 90° Body Support Brackets until they seat against the body's inner liner, Tighten the two 5/16 – 18 x 3/4 HHCS and nyloc nuts on the Adjustable 90° Support Brackets
5. Align the muffler with the muffler cutout in the body
6. Center the Trike Body left to right measuring off the rotors with a carpenter's square
7. Reinstall the Exhaust Heat Shields

Securing the Trike Body

Note: A small section of Trike Body Carpet has not been glued at the location of the Trike Body Frame mounting tabs to allow removal of the bolts used in shipping, and installation of the Trike Body mounting hardware. The predrilled bolt holes may need to be enlarged or relocated for Trike Body attachment to the Trike Body Frame mounting tabs. If relocation is necessary, the preexisting holes will need to be sealed with silicone sealant.

1. Using a 5/16 twist drill, drill up through the Trike Body Frame mounting tabs
2. Insert 5/16–18 x 1 1/4 HHCS, fender washer, and rubber washers if necessary, through the holes drilled
3. Install nyloc nuts and flat washers onto the rear HHCS and tighten
4. Using a 5/16 twist drill, drill up through the Adjustable 90° Body Support Brackets
5. Insert 5/16–18 x 1 1/4 HHCS and fender washers through the adjustable 90° body support brackets.
6. Install nyloc nuts and flat washers onto the front HHCS and tighten
7. Use silicone to seal the shipping holes and to glue the carpet down
8. Re-align the Mufflers and tighten hardware
9. Reinstall the 4 triangle shaped black plastic frame covers

Tour Box Installation

1. Lower the Tour Box in place on the body
2. Install 3 5/16 x 1 1/2 HHCS with flat washers in the center of the Tour Box, Secure with fender washers & nyloc nuts inside the body & tighten
3. Cut the Chrome bar as shown, 7 inches from the front of the bar. Discard 7in stubs

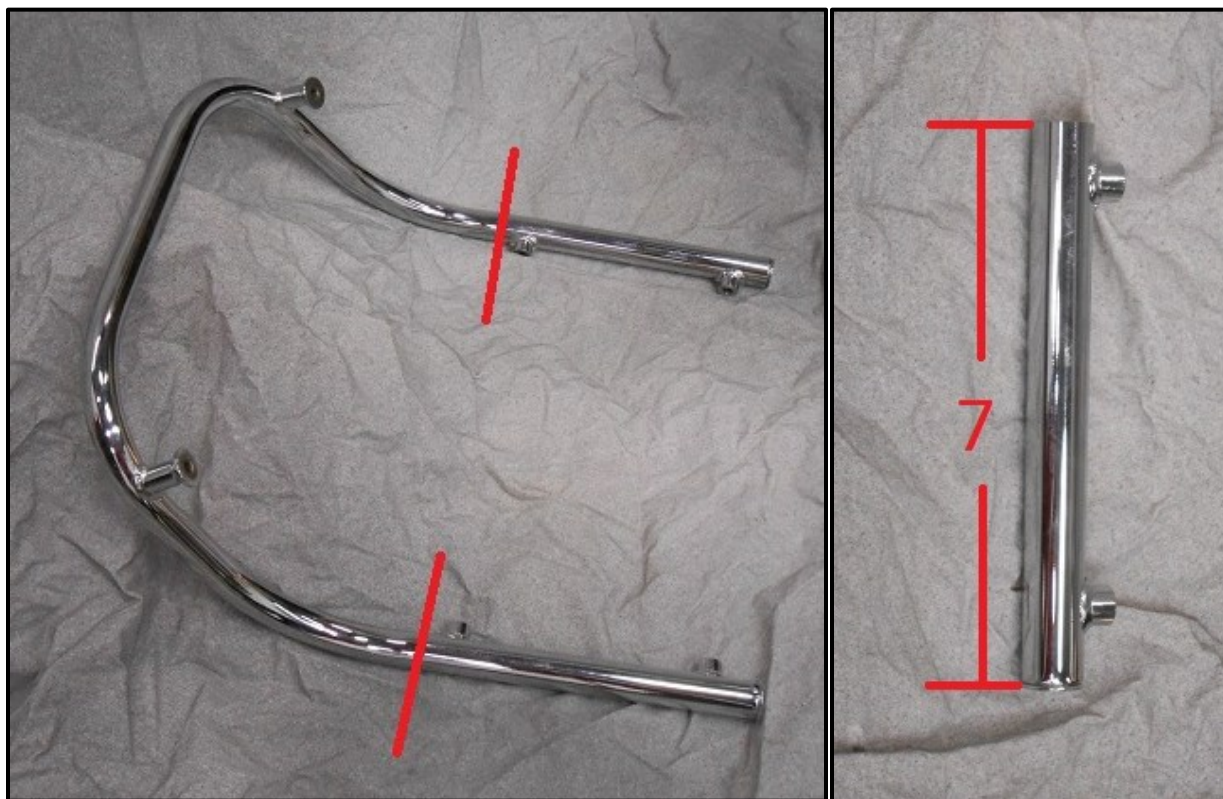

4. Install 2 well nuts in the cut end of the Chrome Bar
5. Install the cut Chrome Bar with 2 5/16 x 1 1/2 HHCS, flat washers & the 2 OEM fasteners & washers & tighten
6. Install 4 more 5/16 x 1 1/2 HHCS with fender washers in the perimeter holes inside the Tour Box now secure with fender or flat washer & tighten

Radio Antenna equipped Motorcycles:

1. Drill a 5/16 hole 1 ½ inches to the right of the chrome bar at the same height. Refer to picture
2. Drill a 7/16 hole in the front of the tour box for the antenna cable as shown
3. Split the grommet and install in hole
4. Route antenna wire with the rest of the wire harness, secure and plug in



5. Plug in the Tour Box harness to the Amp, now remove the wire extension from the seat and plug it into the Tour Box and the Motorcycle harness, then secure it
6. Reinstall the OEM liner

7. Before you install the Seat, you need to cut the openings in the front ¼ inch rearward so the seat will install and remove easier. Refer to picture below

BEFORE



AFTER





Final Assembly

1. Connect the fender plug to the trike body plug
2. Connect the RED fusible link wire on the Battery Harness to the positive battery post and the BLACK wire to the negative post. Plug the Battery Harness into the trike body.
3. Reinstall the battery box cover, seat, and upper side covers
4. Reinstall the wheel and tire assemblies with ten m12 x 1.5 ET conical lug nuts. Torque to 75 FT-LBS
5. Reinstall the Wheel Skirts & secure them with 4 hitch pins
6. Recommended tire pressure
 - 15 & 16" wheels – 28 psi
 - 17" wheels – 25 psi

From all of us at California Sidecar.
Enjoy the ride.

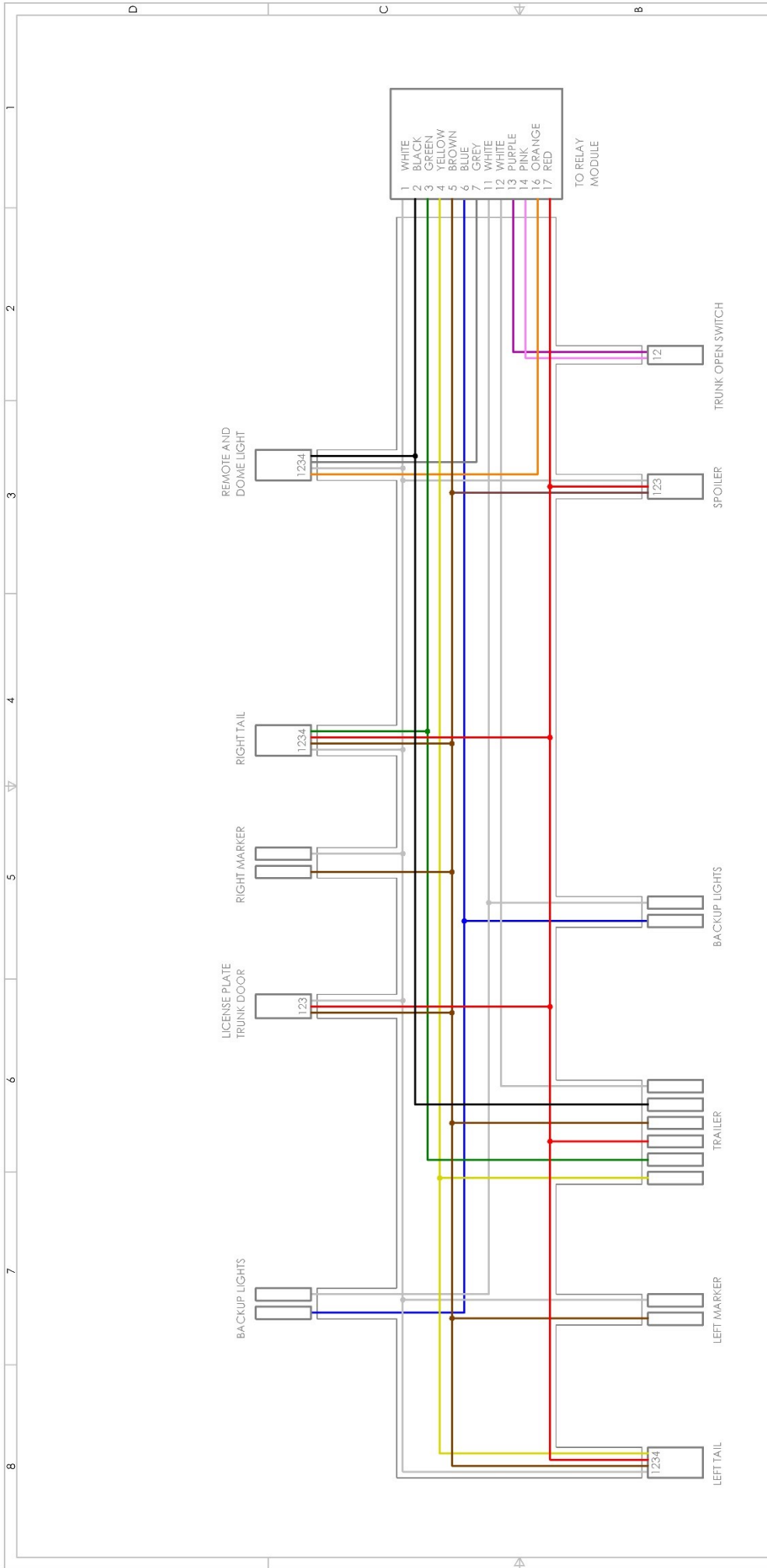

- WIRE COLORS:**
 BLACK: 12V CONSTANT
 BROWN: 12V SWITCHED WITH RUNNING LIGHT
 RED: BRAKE
 GREEN: RIGHT TURN
 YELLOW: LEFT TURN
 BLUE: BACKUP
 ORANGE: REMOTE SWITCHED POWER
 GREY: TRUNK LATCH OPEN LIGHT
 WHITE: GROUND
 PINK: TRUNK OPEN SWITCH
 PURPLE: TRUNK OPEN SWITCH

California Side Car Inc.
 100 MOTORCYLE RUN, ARRINGTON, VA 22922

TITLE		TRIKE WIRE HARNESS INSIDE BODY	
SIZE	PART NUMBER	REV	
B	ELC-21117	A	
SCALE	VENDOR DRW NUMBER	SHEET	
1:1	N/A	3 OF 3	

THIS DOCUMENT AND ANY COPYRIGHTED MATERIAL CONTAINED HEREIN ARE THE PROPERTY OF CALIFORNIA SIDE CAR INC. AND ARE NOT TO BE REPRODUCED OR TRANSMITTED IN ANY FORM OR BY ANY MEANS, ELECTRONIC OR MECHANICAL, INCLUDING PHOTOCOPYING, RECORDING, OR BY ANY INFORMATION STORAGE AND RETRIEVAL SYSTEM, WITHOUT THE WRITTEN PERMISSION OF CALIFORNIA SIDE CAR INC. ANY USE OF THIS INFORMATION CONTAINED HEREIN MAY RESULT IN LIABILITY UNDER APPLICABLE LAWS.