

Quaife Quick Ratio 88 CRX DX Steering Rack Upgrade
Michael & Mark Olson
4/12/2011

This is a how-to that will help you to upgrade a CRX-DX steering rack with a Quaife quick-ratio rack and pinion.

First, we strongly recommend that you get a copy of the Helms manual and follow their instructions as you rebuild the rack with the Quaife Rack and Pinion.

Since we didn't know how much wear there had been on our donor steering rack, we decided to replace most of the parts in the rack, so we ordered new boots, a new rack guide, disk washer and spring from hondapartscheap.com We also ordered a new pinion dust seal, and new stopper washers and lock washers for the tie-rods. If we had it to do over again, we'd have also replaced the rack end bushing too, although ours is still in good shape.

We also ordered the Quaife quick-ratio steering upgrade kit.

We started the project by removing the boot bands and the old torn up boots. We then flattened the lock washers and then removed the tie-rods.

We had to use a pipe wrench to loosen the Rack Guide Screw lock nut because we didn't have another wrench large enough to do the job. We then removed the Rack Guide Screw, the spring, the disc washer and the rack guide:



We had to destroy the pinion dust seal to get it off. Then we removed the 35mm Internal snap ring using snap ring pliers.

We had to put the universal knuckle back on the pinion so we could use it with a block of wood and a hammer to drive the pinion out of the gearbox housing.

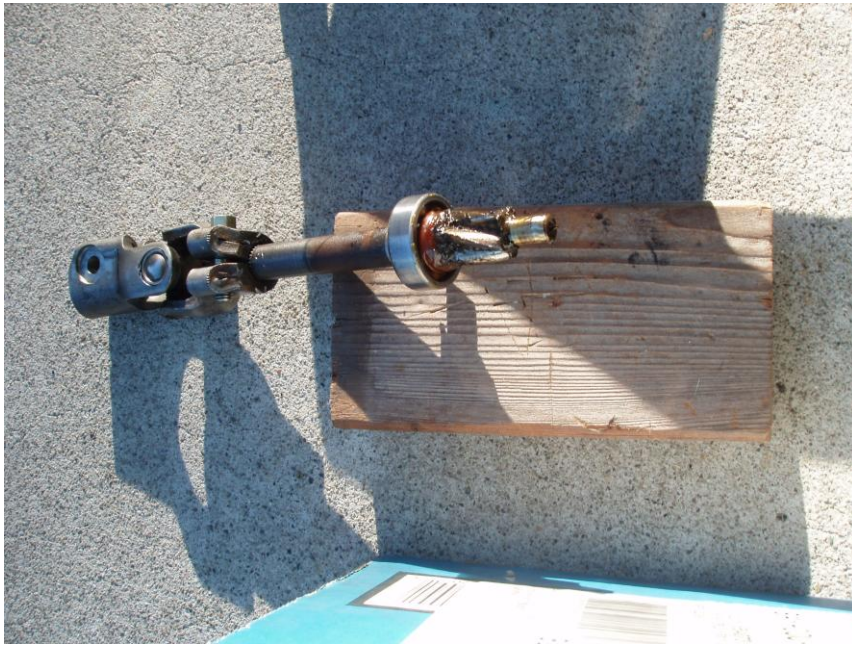

We then pulled out the rack and put it side by side with the new Quaife rack (and the new Quaife pinion):



We were surprised that the Quaife kit didn't come with a new pinion bearing. And the shop manual confused us by saying, "NOTE: The pinion assembly bearing cannot be removed. If the bearing must be replaced, replace as an assembly." We thought that that meant you couldn't get the pinion bearing separate from the pinion. After a little forum posting and an email exchange with Quaife, we ordered an OEM pinion bearing. But we were still confused about the keeper on the pinion bearing shaft. As you can see, Honda used a machine to crimp two sides of a washer so the washer clamped into the keeper slot on the pinion shaft:



We emailed Quaife about the keeper and they said they had never been asked about it before. They suggested using a circlip if we were concerned about it. We measured the pinion shaft to be 15mm in diameter, and the keeper slot to be 13mm in diameter. But we weren't able to find a metric circlip, so we bought a 1/2" circlip because it was close, although a little too small. We used a compass to draw a 13mm circle, and laid the circlip on it to see how much of the inner prongs needed to be cut:

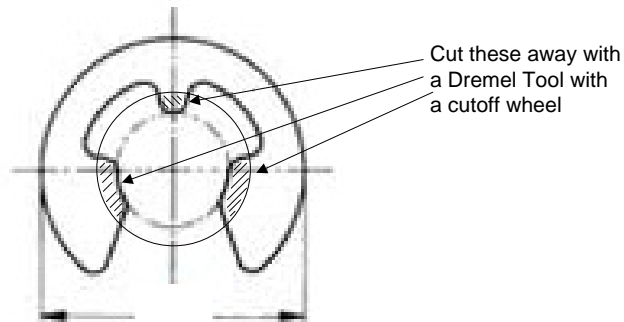

It is not clear that this circlip is actually needed. The pinion bearing is a press fit both on the pinion shaft and in the gearbox body. It is also held in place by the 35mm inside snap-ring, and the pinion is held in by the bearing. However, we felt that, since the Honda engineers put a keeper in, then we should too for steering safety.

We then used a small block of wood and a hammer to drive the new bearing onto the Quaife pinion shaft. We popped the circlip into the slot on the shaft and it fit perfectly:



We pulled out the rack end bushing and applied a thin layer of grease to the inside. Be careful not to clog the air channels with grease because air needs to flow through the bushing.



We inserted the bushing back into the rack tube:



We greased the rack:



We slid the rack back into the housing:



With a Dremel tool with a cutoff wheel, we cut the bearing keeper off of the stock pinion shaft, and drove the bearing off of the pinion. We cut the center out of the bearing to get the stock bearing race. We used the bearing race with a hammer to drive the pinion and bearing into the gearbox housing:



We replaced the internal 35mm snap ring:

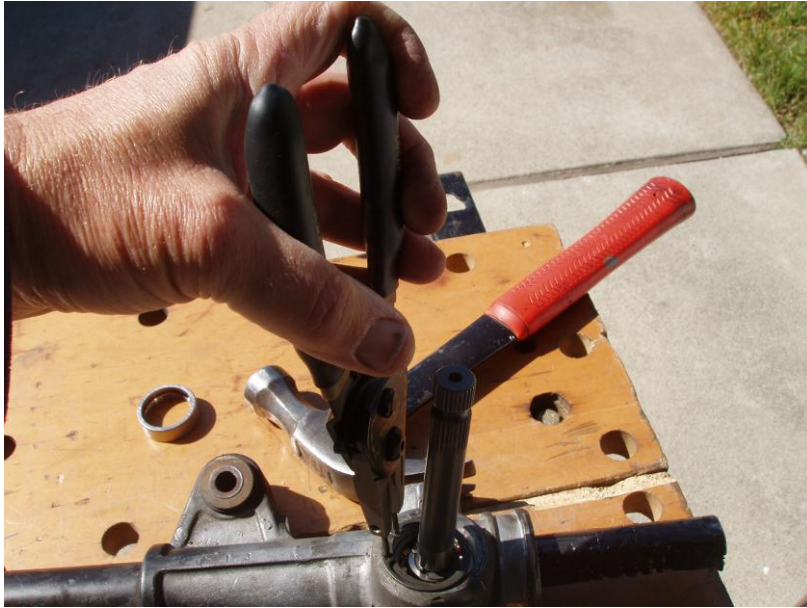

And the pinion is now securely in place:

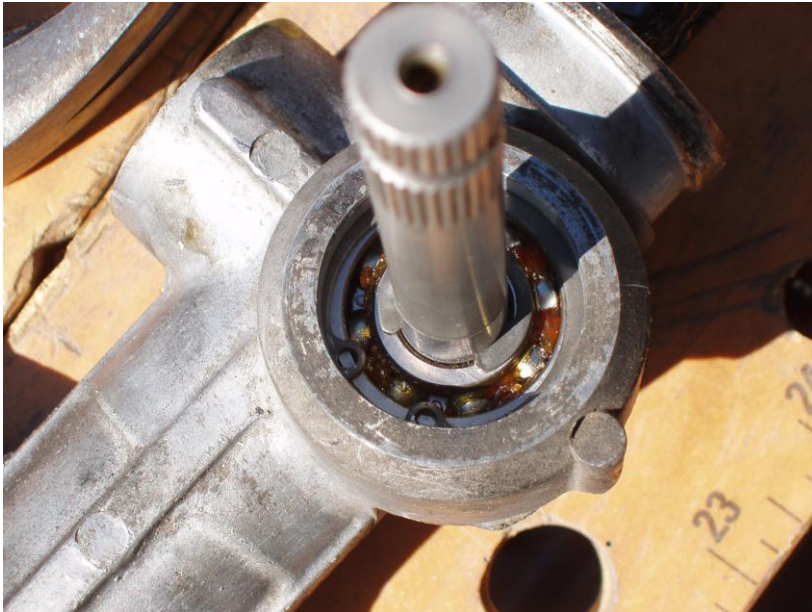

We greased the pinion dust seal, and used the old pinion bearing race and a hammer to tap the dust seal into place:



Here is the new rack guide next to the old one,



We coated the new rack guide with grease.

We installed the rack guide and new spring and put the new washer on the rack guide screw with a little grease to hold it in place. Make sure you put the concave side of the washer towards the screw as shown in the Helms manual.

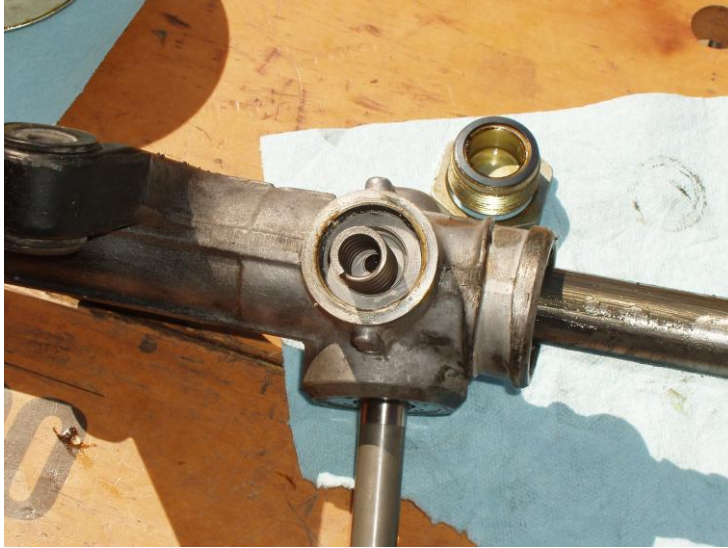

It takes some serious pushing against the spring to get the rack guide screw started in the threads. The torque specs say to torque it to 3.6 ft-lbs, and our small torque wrench only goes down to 5 ft-lbs, so we set it one click below 5 ft-lbs. Not much torque needed. You have to tighten it and loosen it two times and torque it again. Then you back the screw off 15 degrees before the final torque down of the lock nut. We then held the screw with a socket wrench while we torqued the big lock nut down to 49 ft-lbs using a pipe wrench. Not too scientific and it chewed up the nut a bit, but it was a lot cheaper than trying to buy the special wrench needed.

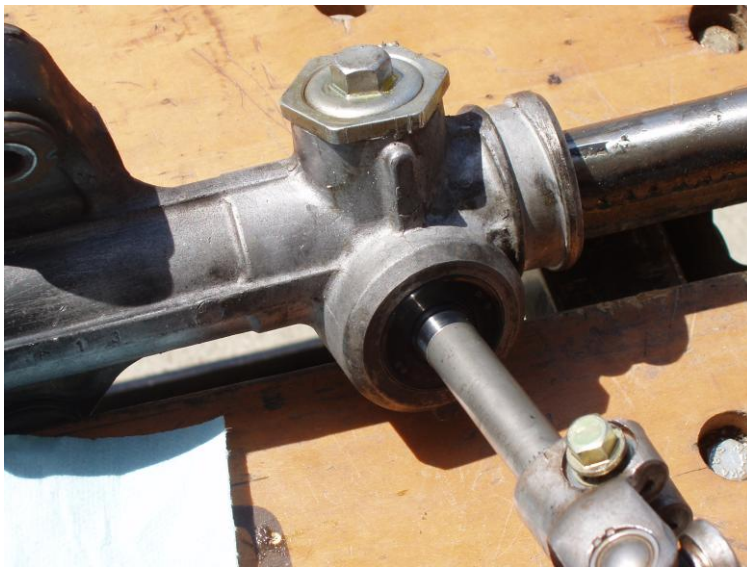

Next we went to work on the tie-rods.

Here are the tie-rod washers:



And how they go on each end of the rack. Make sure the tabs in the lock washers slide into the slots on the rack ends::

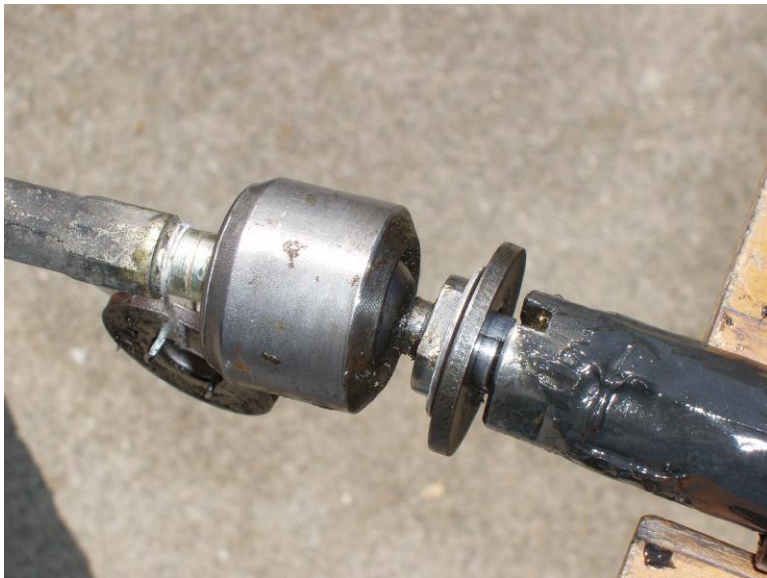

Tighten down the rods:

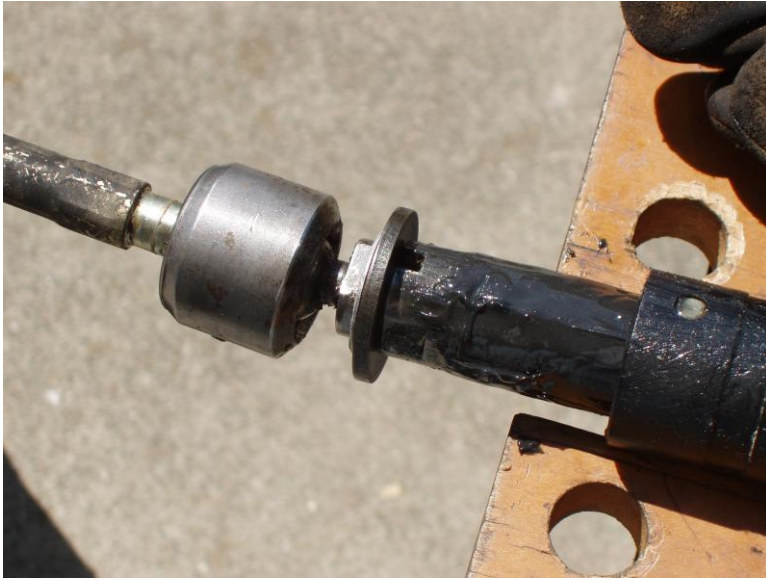

Using a chisel and a punch, flatten the lock washers against the flat sides of the tie-rods:



Install the boots:



We re-used our old tube clamps and put on new boot bands:



We ran the rack back and forth to ensure the boots did not twist or collapse.

And the rack rebuild is done:



We next plan to install polyurethane mounting bushings and new tie-rod ends before we install the rack in the car.

Good luck with your project.